



US00D974231S

(12) **United States Design Patent** (10) **Patent No.:** **US D974,231 S**
Pemberton et al. (45) **Date of Patent:** **** Jan. 3, 2023**

(54) **RAIL VEHICLE**
(71) Applicant: **The Council of the City of Coventry**,
Coventry (GB)
(72) Inventors: **Martin Pemberton**, St Ives (GB); **Paul Salkeld**, Redditch (GB); **Matthew Hall**,
Warwick (GB)
(73) Assignee: **THE COUNCIL OF THE CITY OF COVENTRY**, Coventry (GB)
(**) Term: **15 Years**
(21) Appl. No.: **29/750,219**
(22) Filed: **Sep. 11, 2020**
(51) **LOC (14) Cl.** **12-17**
(52) **U.S. Cl.**
USPC **D12/43**
(58) **Field of Classification Search**
USPC D12/1, 36, 37, 38, 39, 40, 41, 42, 43;
D21/533, 540, 541, 548, 552
CPC B60L 2200/26; B29C 66/82263; B61D
19/02; B61C 3/00; B61C 7/00; B65G
1/065; B61F 3/08
See application file for complete search history.

D854,968 S * 7/2019 Giroux D12/39
D901,331 S * 11/2020 Giroux D12/36
D904,929 S * 12/2020 Simpson D12/36
D911,218 S * 2/2021 Ransome D12/36
D911,219 S * 2/2021 Simpson D12/37

OTHER PUBLICATIONS

Coventry VLR project, Published Jun. 18, 2018 [online]. [retrieved on Jul. 16, 2022]. Retrieved from the Internet: <https://www.railtechnologymagazine.com/News-Robot/firm-named-for-new-coventry-vlr-project> (Year: 2018).*
Very Light Rail Website—<https://web.archive.org/Web/20180605221853/http://www.verylightrail.com/> Jun. 5, 2018.
Coventry City Council—<https://web.archive.org/web/20181031112822/https://www.coventry.gov.uk/verylightrail/> Oct. 31, 2018.

(Continued)

Primary Examiner — Cary M Robinson
Assistant Examiner — Adam C Mager
(74) *Attorney, Agent, or Firm* — Thomas Coester
Intellectual Property

(57) **CLAIM**

The ornamental design for a rail vehicle, as shown and described.

DESCRIPTION

FIG. 1 is a front perspective view of a rail vehicle according to the present invention.
FIG. 2 is a right-side view thereof.
FIG. 3 is left-side view thereof.
FIG. 4 is a front view thereof.
FIG. 5 is a rear view thereof.
FIG. 6 is a top view thereof; and,
FIG. 7 is a bottom view thereof.
The broken lines shown in the drawings are features of the rail vehicle that form no part of the claimed design.

1 Claim, 6 Drawing Sheets

(56) **References Cited**
U.S. PATENT DOCUMENTS
D331,033 S * 11/1992 Renfrew D12/40
D466,050 S * 11/2002 Forey D12/84
D503,127 S * 3/2005 Miernik D12/100
D563,831 S * 3/2008 Suge D12/84
D700,542 S * 3/2014 Warren D12/84
D757,604 S * 5/2016 Joren D12/36
D758,244 S * 6/2016 Greenway D12/36
D834,449 S * 11/2018 Pelletier D12/84

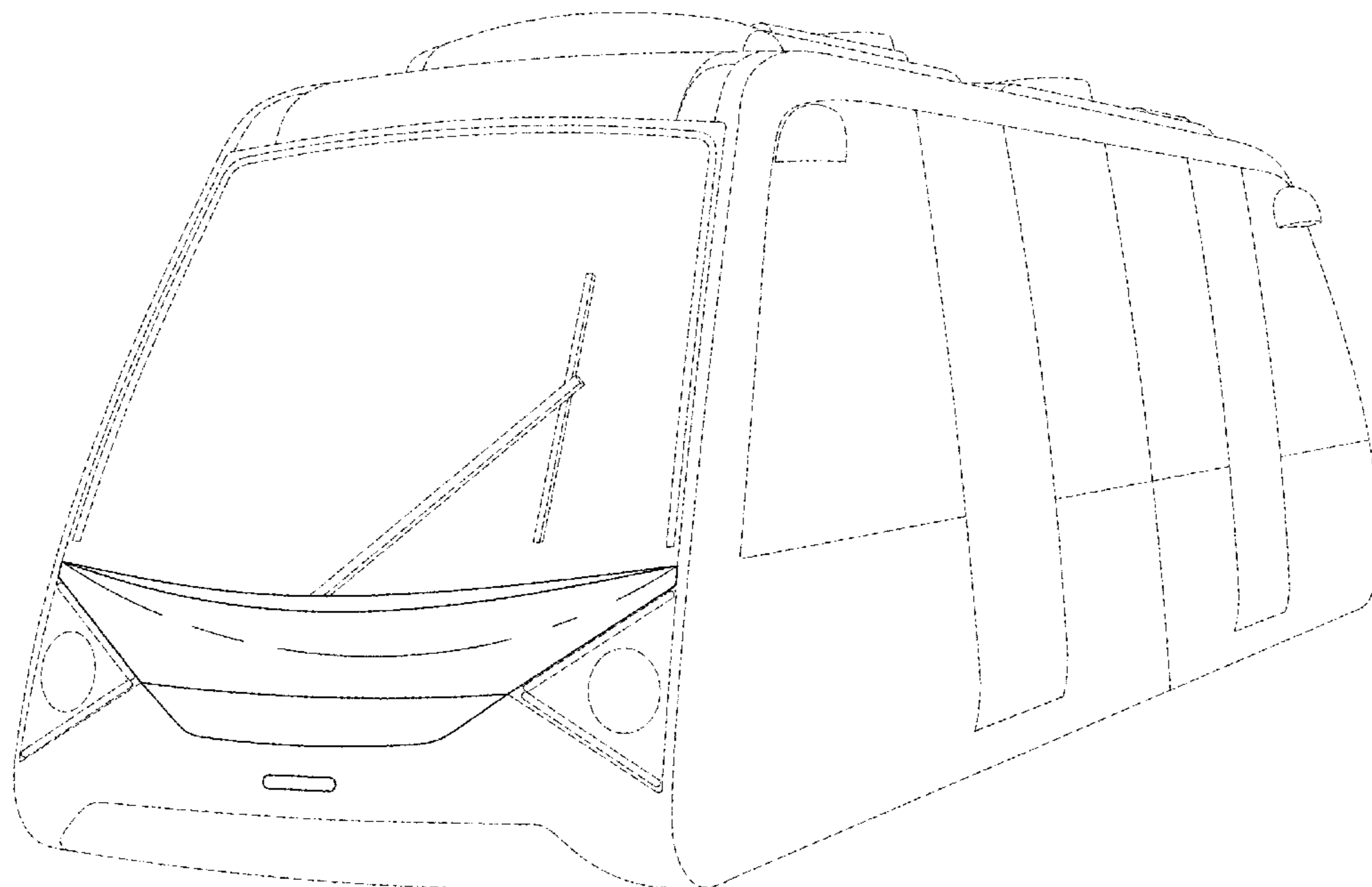

(56)

References Cited

OTHER PUBLICATIONS

Global Rail News—<https://www.globalrailnews.com/2018/01/08/plans-submitted-to-make-dudley-a-worldwide-leader-in-very-light-rail/> Jan. 18, 2018.

The Boar—<https://theboar.org/2017/10/wmg-developing-electric-tram-connect-coventry/> Oct. 23, 2017.

Revolution VLR, TDi—<https://web.archive.org/web/20141024173943/https://www.tdi.uk.com/en/revolution-vlr-consortium/> Oct. 24, 2014.

Revolution VLR, TDi—<https://web.archive.org/web/20160405045206/https://www.tdi.uk.com/en/revolution-vlr-consortium/> Apr. 5, 2015.

Revolution VLR, TDi—<https://web.archive.org/web/20161017072622/https://www.tdi.uk.com/en/revolution-vlr-consortium/> Oct. 17, 2016.

Revolution VLR, TDi—<https://web.archive.org/web/20170927053648/https://www.tdi.uk.com/en/revolution-vlr-consortium/> Sep. 27, 2017.

Revolution VLR, TDi—<https://web.archive.org/web/20180703180158/http://www.tdi.uk.com/EN/revolution-vlr-consortium/> Jul. 3, 2018.

Coventry Very Light Rail, TDi—<https://www.tdi.uk.com/EN/coventry-very-light-rail-1/> Sep. 27, 2017.

Global Rail News—<https://www.globalrailnews.com/2017/09/29/this-is-what-a-coventry-tram-system-could-look-like/> Sep. 29, 2017.

BBC—<https://www.bbc.co.uk/news/uk-england-coventry-warwickshire-41426029> Sep. 28, 2017.

NCE—<https://www.newcivilengineer.com/archive/coventry-light-rail-design-deal-awarded-19-01-2018/> Jan. 19, 2018.

BBC—<https://www.bbc.co.uk/news/uk-england-coventry-warwickshire-42745007> Jan. 19, 2018.

Touch FM—<https://web.archive.org/web/20190104191507/http://www.962touchfm.co.uk/round-here/news/local-news/company-chosen-to-build-coventry-trams/> Jun. 14, 2018.

Coventry LEP—<https://www.cwlep.com/news/contractor-announced-very-light-rail-coventry> Jun. 14, 2018.

Railway Gazette—<https://www.railwaygazette.com/vehicles/very-light-rail-vehicle-prototype-contract-awarded/46630.article> Jun. 15, 2018.

Rail Technology Magazine—<http://www.railtechnologymagazine.com/Rail-News/firm-named-for-new-coventry-vlr-project> Jun. 18, 2018.

Express & Star—<https://www.expressandstar.com/news/business/2018/06/20/plans-for-very-light-rail-in-dudley-given-a-boost/> Jun. 21, 2018.

Cenex (LCV2018) by Nick Mallinson—https://www.cenex-lcv.co.uk/storage/seminar-programme/sessions/presentations/nick_mallinson_very_light_rail_vlr_as_a_means_of_delivering_low_cost_railways_1537363565.pdf Sep. 12-13, 2018.

Presentation to Bath Tram Conference 2018—<https://bathtrams.uk/cms/wp-content/uploads/2018/12/Bath-Tram-Conference-Nick-Mallinson.pdf> Nov. 24, 2018.

Rail Technology Magazine—<http://www.railtechnologymagazine.com/Rail-News/spotlight-on-coventry-vlr-> Nov. 27, 2018.

Coventry Telegraph (Coventry Live)—<https://www.coventrytelegraph.net/news/coventry-news/coventrys-trams-could-travel-across-15487183> Dec. 3, 2018.

Warwick University—https://warwick.ac.uk/newsandevents/pressreleases/very_light_rail/ Sep. 27, 2017.

* cited by examiner



FIG. 1

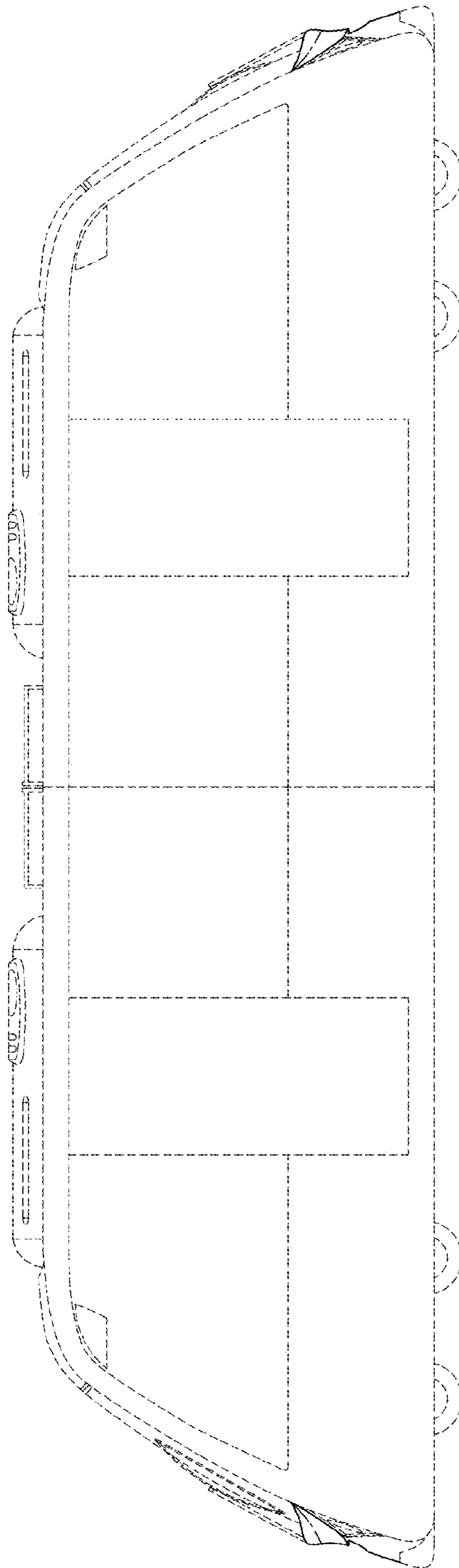

FIG. 2

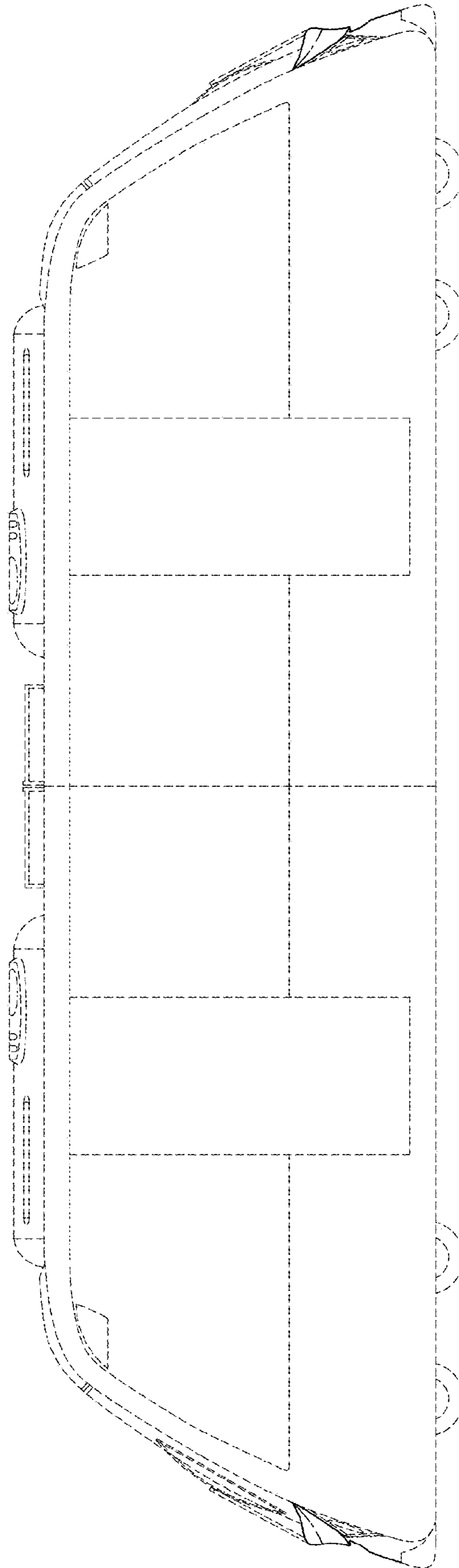

FIG. 3

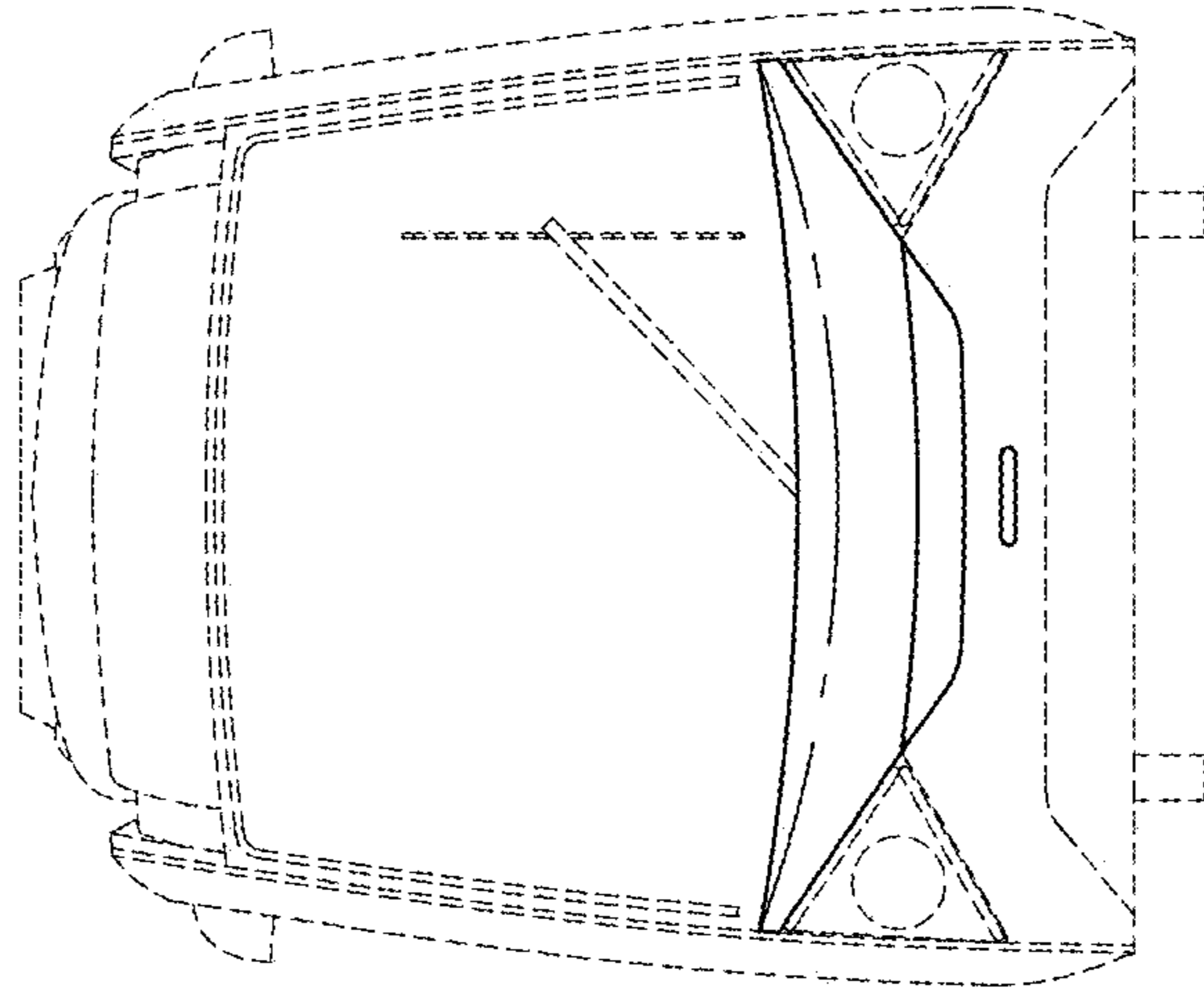

FIG. 5

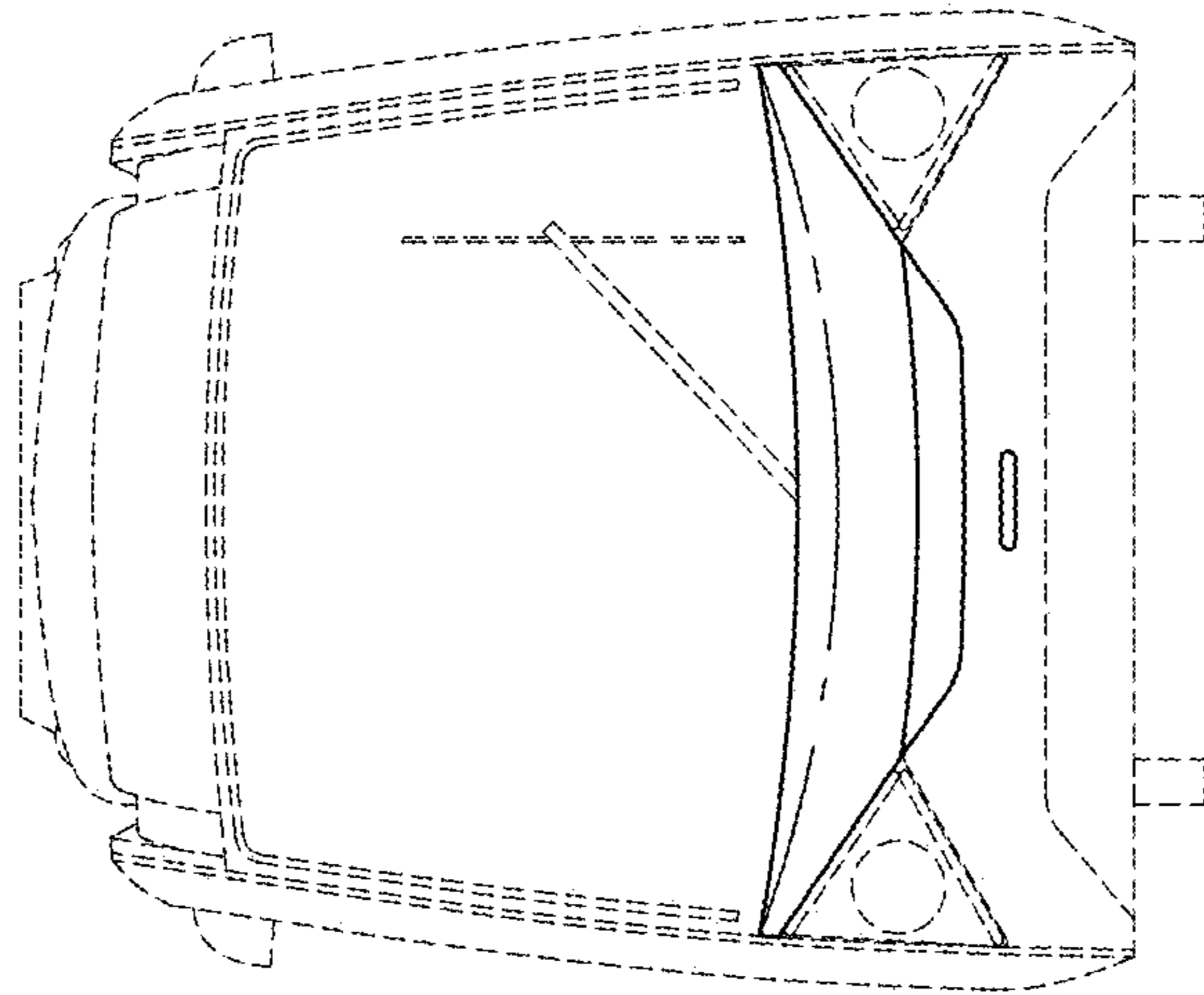

FIG. 4

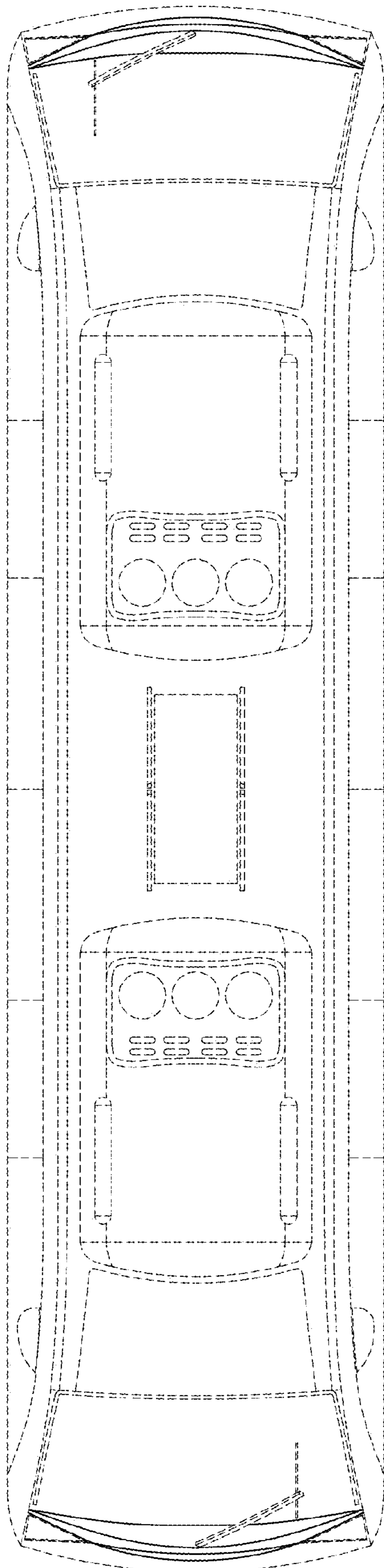

FIG. 6



FIG. 7