



US00D974192S

(12) **United States Design Patent**
Larsen

(10) **Patent No.:** **US D974,192 S**
(45) **Date of Patent:** **** Jan. 3, 2023**

(54) **SOIL MOISTURE SENSOR**

(71) Applicant: **Smart Rain Systems, LLC,**
Centerville, UT (US)

(72) Inventor: **Rudy Lars Larsen,** Bountiful, UT (US)

(73) Assignee: **SMART RAIN SYSTEMS, LLC,**
Centerville, UT (US)

(**) Term: **15 Years**

(21) Appl. No.: **29/776,335**

(22) Filed: **Mar. 29, 2021**

(51) **LOC (14) Cl.** **10-05**

(52) **U.S. Cl.**
USPC **D10/56**

(58) **Field of Classification Search**
USPC D10/52, 53, 54, 56, 57, 60, 96, 97, 101;
D11/146; D24/187; D26/67
CPC G01W 1/14; A01G 25/167
See application file for complete search history.

(56) **References Cited**

U.S. PATENT DOCUMENTS

- 2,908,112 A * 10/1959 Koistinen A47G 7/00
47/41.11
- 3,177,617 A * 4/1965 Koistinen A47G 7/00
215/377
- D245,513 S * 8/1977 Kopel D24/187
- 4,130,012 A * 12/1978 Lockerby G01N 31/222
422/537
- 4,445,788 A * 5/1984 Twersky G01K 1/026
374/161

(Continued)

FOREIGN PATENT DOCUMENTS

- CN 302288856 * 1/2013
- JP D1609650 * 7/2018

Primary Examiner — George D. Kirschbaum

Assistant Examiner — Lillian Windham

(74) *Attorney, Agent, or Firm* — Ray Quinney & Nebeker
P.C.; Paul N. Taylor

(57) **CLAIM**

The ornamental design for a soil moisture sensor, as shown and described.

DESCRIPTION

FIG. 1 is a front perspective view of my new design for a soil moisture sensor;
 FIG. 2 is a front elevation view of the soil moisture sensor shown in FIG. 1;
 FIG. 3 is a rear elevation view of the soil moisture sensor shown in FIG. 1;
 FIG. 4 is right side view of the soil moisture sensor shown in FIG. 1;
 FIG. 5 is a left side view of the soil moisture sensor shown in FIG. 1;
 FIG. 6 is a bottom plan view of the soil moisture sensor shown in FIG. 1;
 FIG. 7 is a top plan view of the soil moisture sensor shown in FIG. 1;
 FIG. 8 is a front perspective view of another configuration of a soil moisture sensor;
 FIG. 9 is a front elevation view of the soil moisture sensor shown in FIG. 8;
 FIG. 10 is a rear elevation view of the soil moisture sensor shown in FIG. 8;
 FIG. 11 is right side view of the soil moisture sensor shown in FIG. 8;
 FIG. 12 is a left side view of the soil moisture sensor shown in FIG. 8;
 FIG. 13 is a bottom plan view of the soil moisture sensor shown in FIG. 8; and,
 FIG. 14 is a top plan view of the soil moisture sensor shown in FIG. 8.
 Broken lines shown in the drawings form no part of the claimed design.

1 Claim, 6 Drawing Sheets

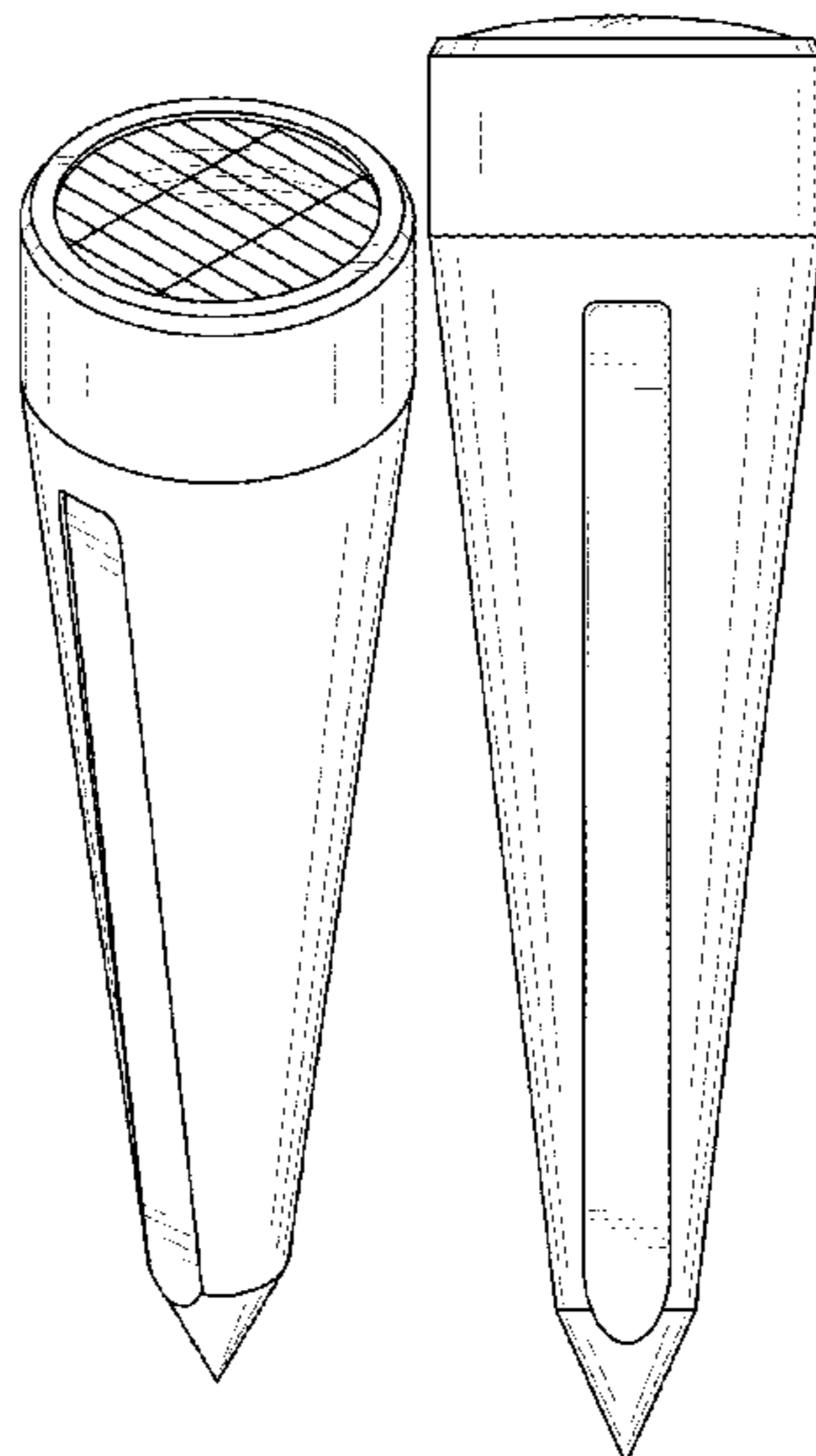

(56)

References Cited

U.S. PATENT DOCUMENTS

4,845,978 A *	7/1989	Whitford	G01N 25/18	7,788,970 B2 *	9/2010	Hitt	A01G 25/167
				73/75					73/73
5,546,697 A *	8/1996	Lymberis	A01G 5/04	D692,325 S *	10/2013	Meyer	D10/53
				47/55	D756,249 S *	5/2016	Xiao	D10/53
D409,925 S *	5/1999	Friedrichs	D10/57	D774,366 S *	12/2016	Joseph	D10/52
D444,079 S *	6/2001	Addink	D10/101	D796,354 S *	9/2017	Chan	A01G 25/167
D453,692 S *	2/2002	Addink	D10/101					D10/56
D461,729 S *	8/2002	Addink	D10/56	D803,706 S *	11/2017	Jackson	D10/60
6,553,852 B1 *	4/2003	Smail	G01N 3/42	D828,186 S *	9/2018	Barnes	A01G 25/167
				73/866.5					D10/56
6,601,440 B1 *	8/2003	Chuang	A01G 25/167	D829,574 S *	10/2018	Mane	G01N 3/42
				73/73					D10/56
D553,516 S *	10/2007	de Groot	G01N 31/222	D841,490 S *	2/2019	Boedhoe	A01G 5/04
				D10/56					D10/56
D554,267 S *	10/2007	Cohen	D24/187	D852,651 S *	7/2019	Basu	G01N 25/18
D572,625 S *	7/2008	Doan	D11/146					D10/52
D609,588 S *	2/2010	Morton	D10/56	D852,652 S *	7/2019	Basu	A47G 7/00
									D10/52
					2020/0267916 A1 *	8/2020	Sol	A01G 27/003
					2021/0251159 A1 *	8/2021	Huang	A01G 27/06

* cited by examiner

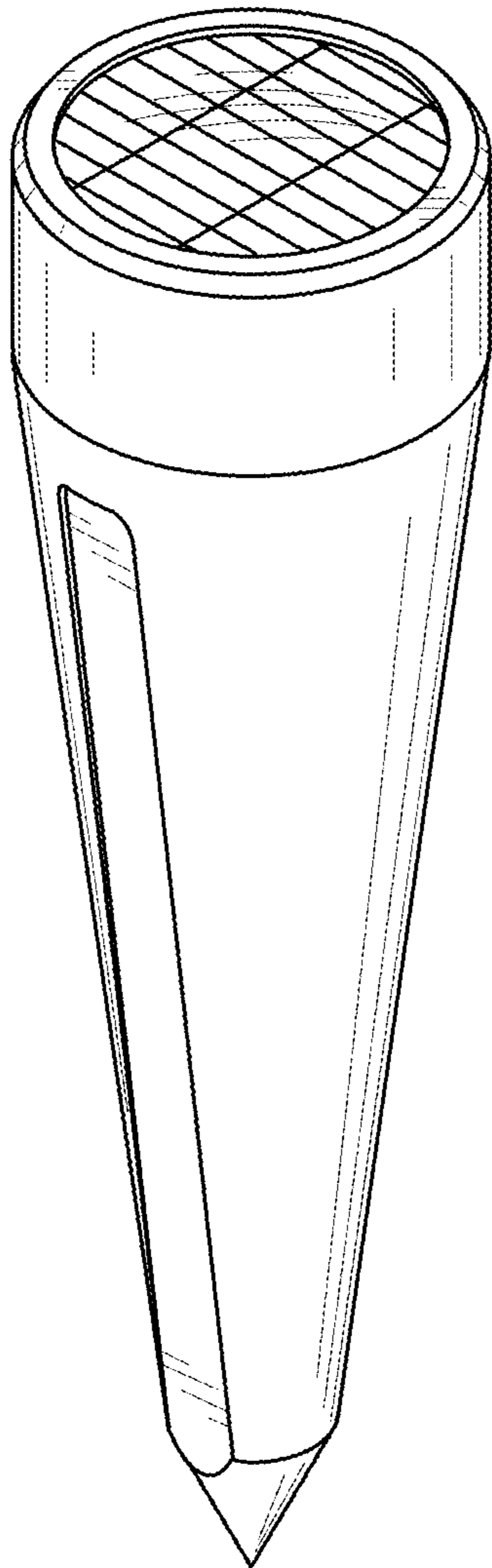

FIG. 1

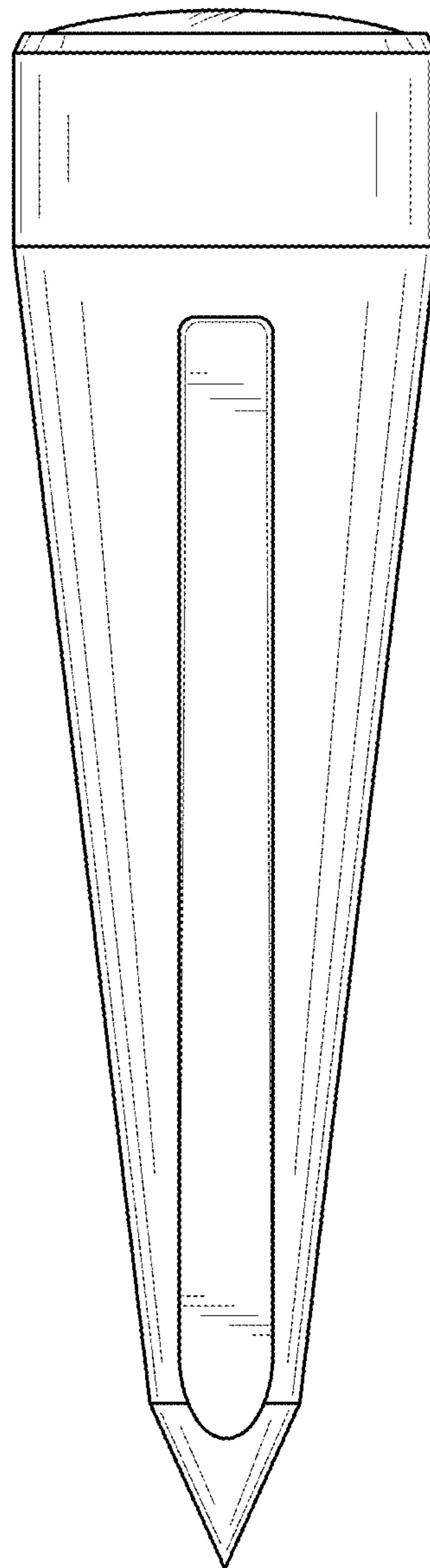

FIG. 2

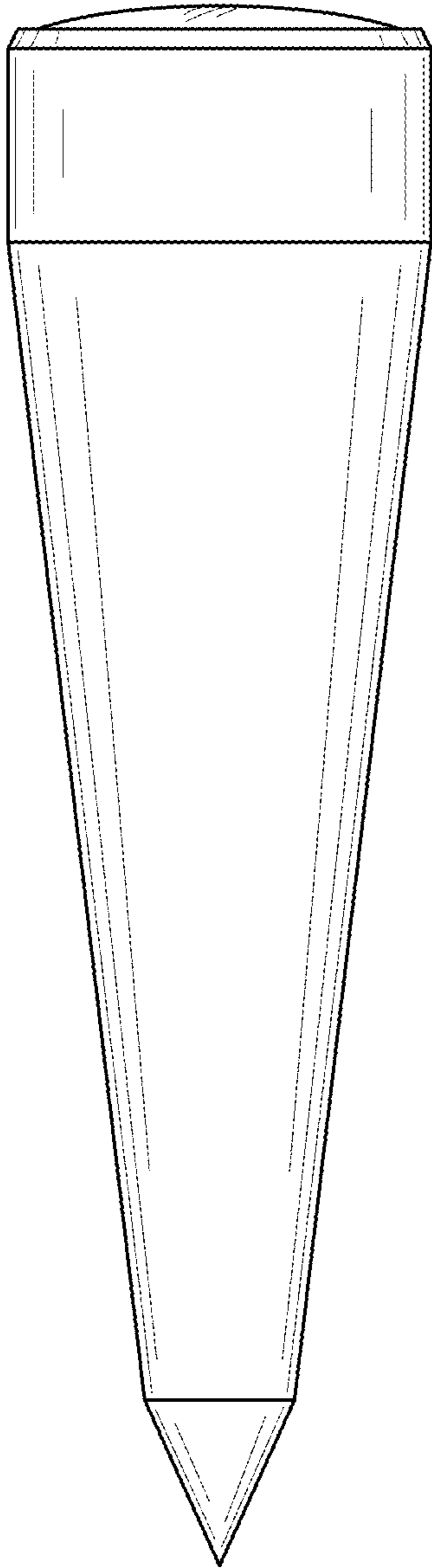

FIG. 3

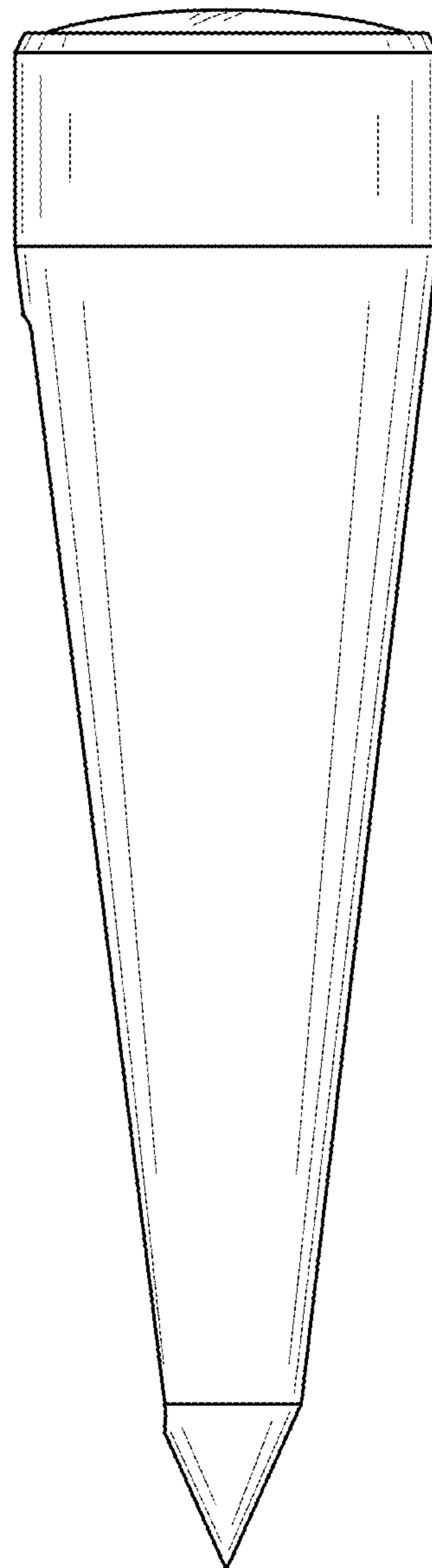

FIG. 4

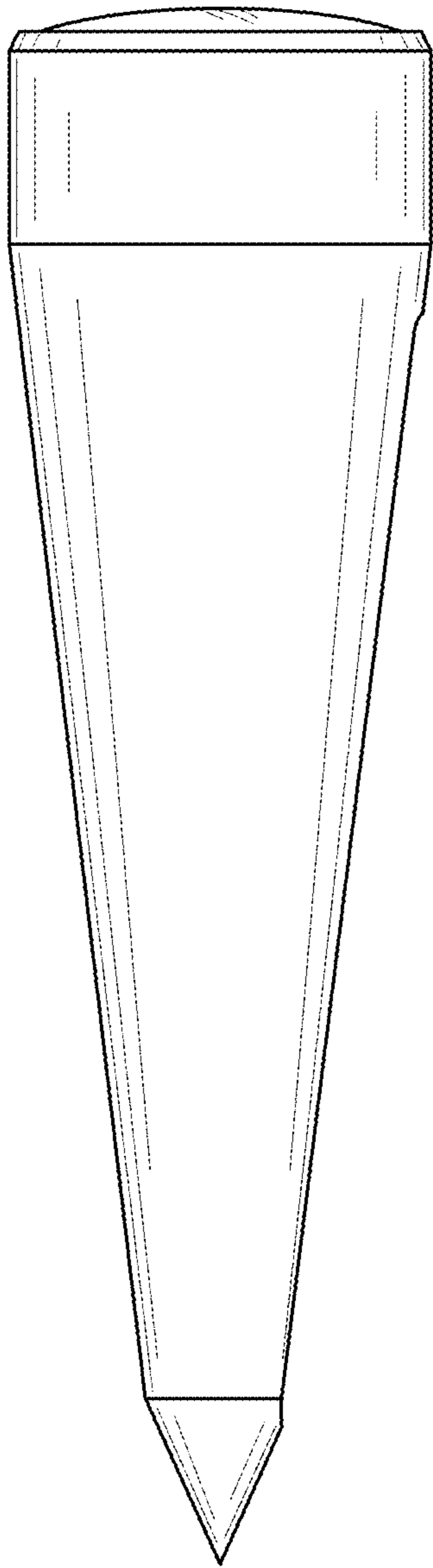

FIG. 5

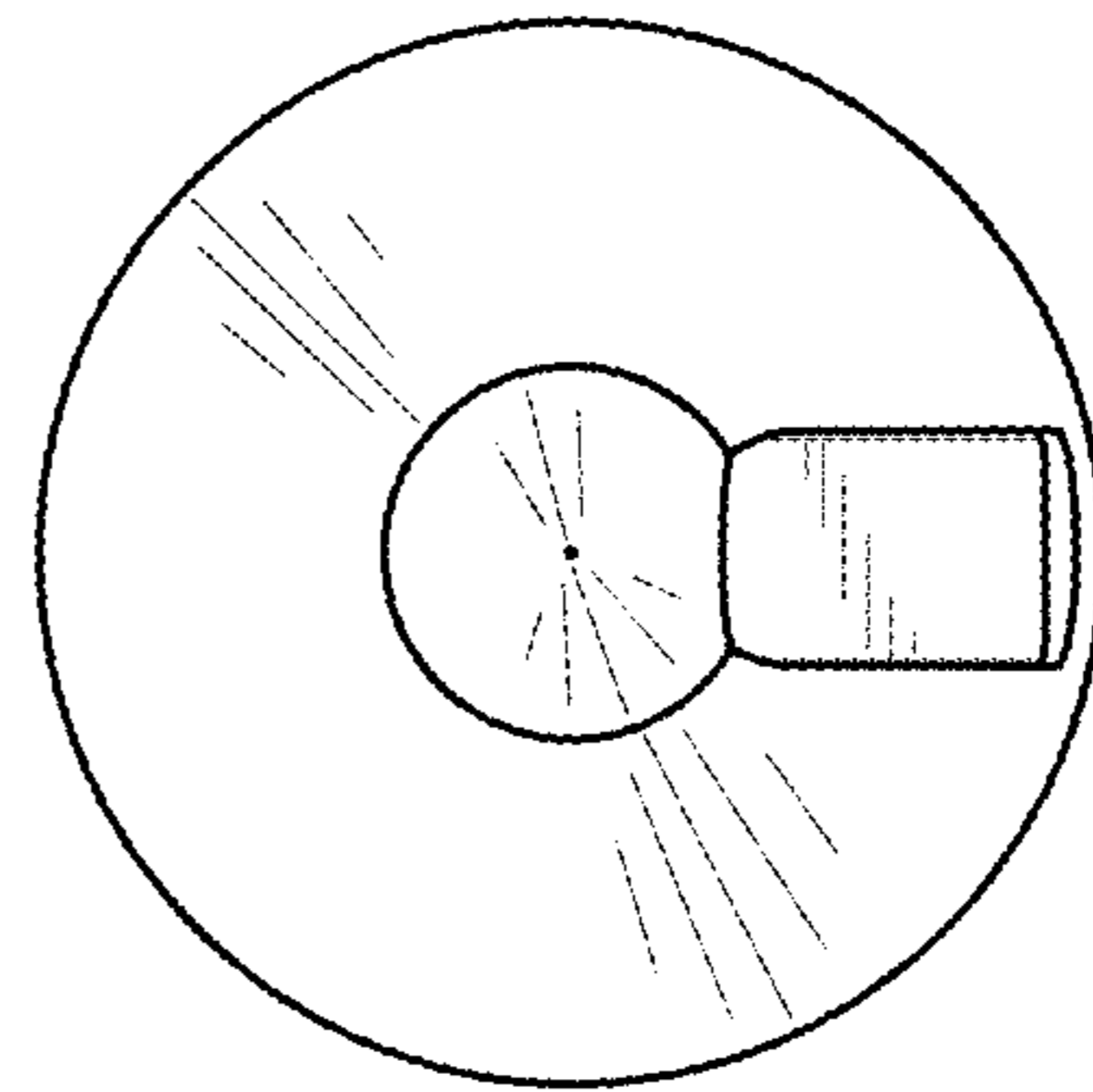

FIG. 6

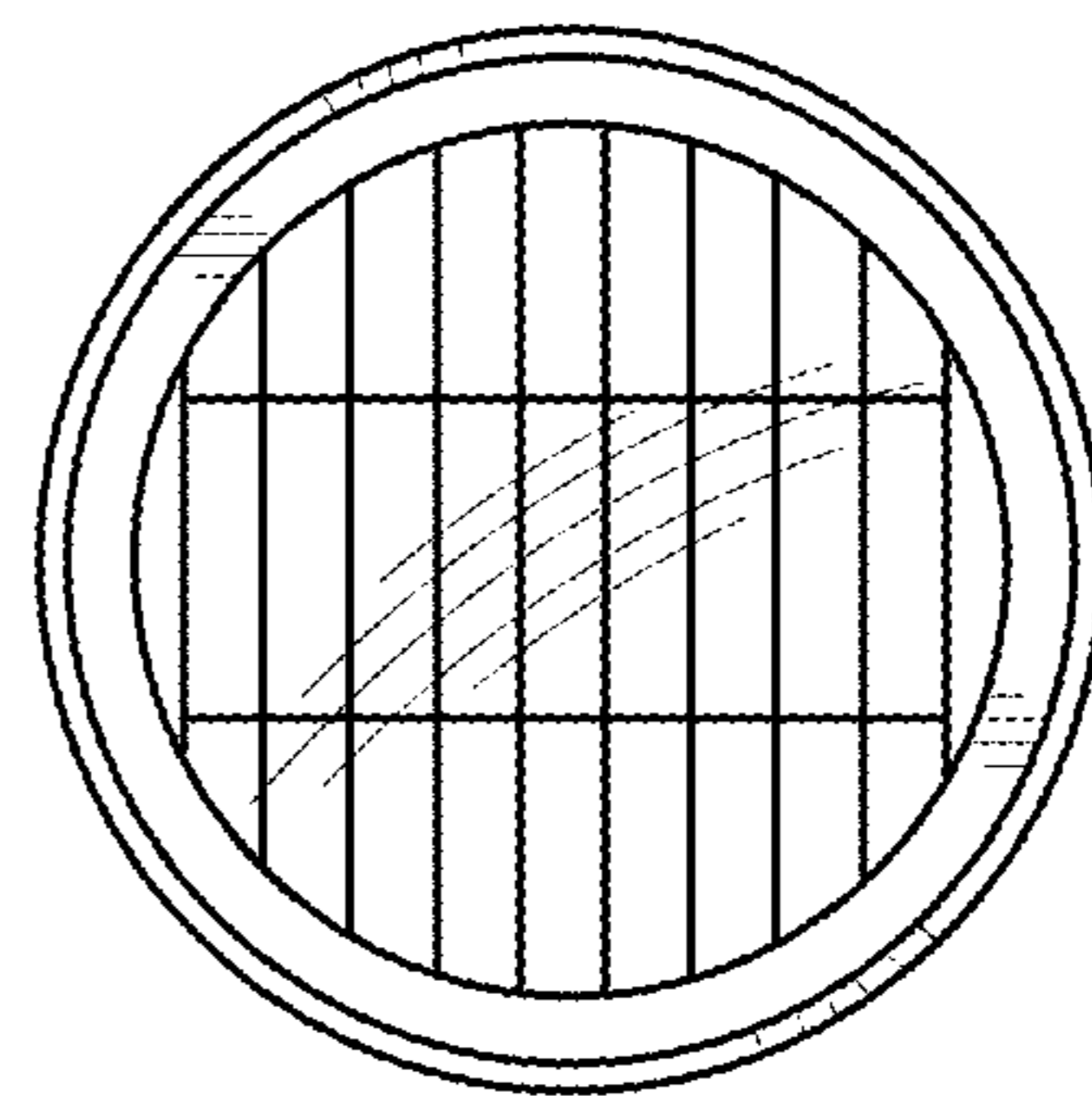

FIG. 7

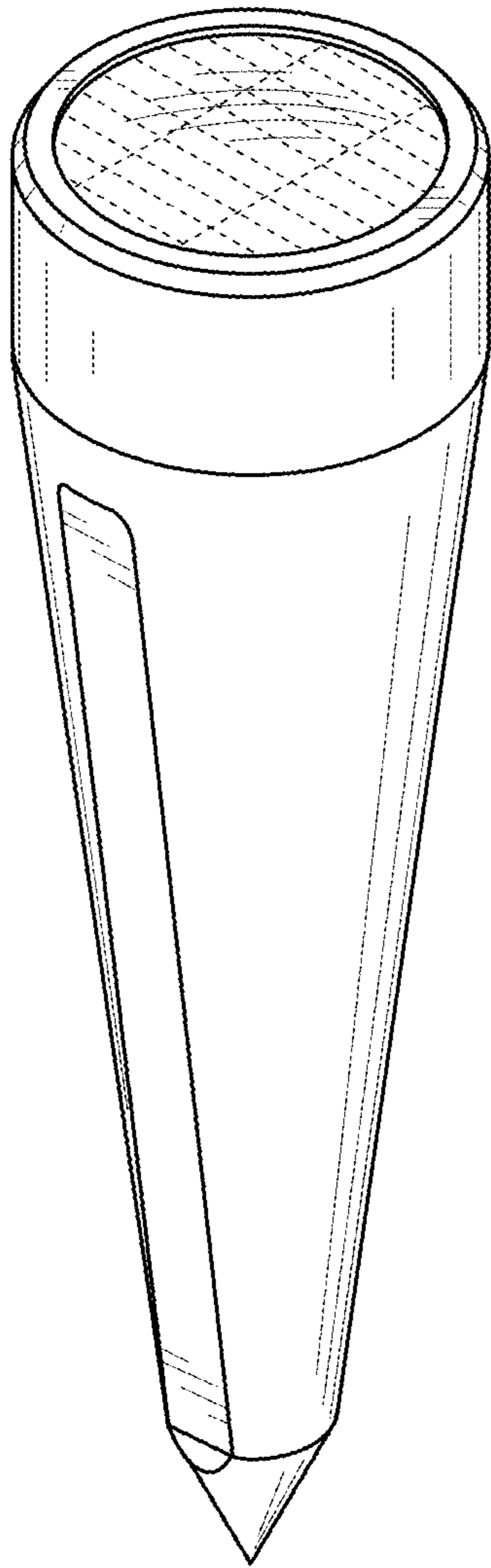

FIG. 8

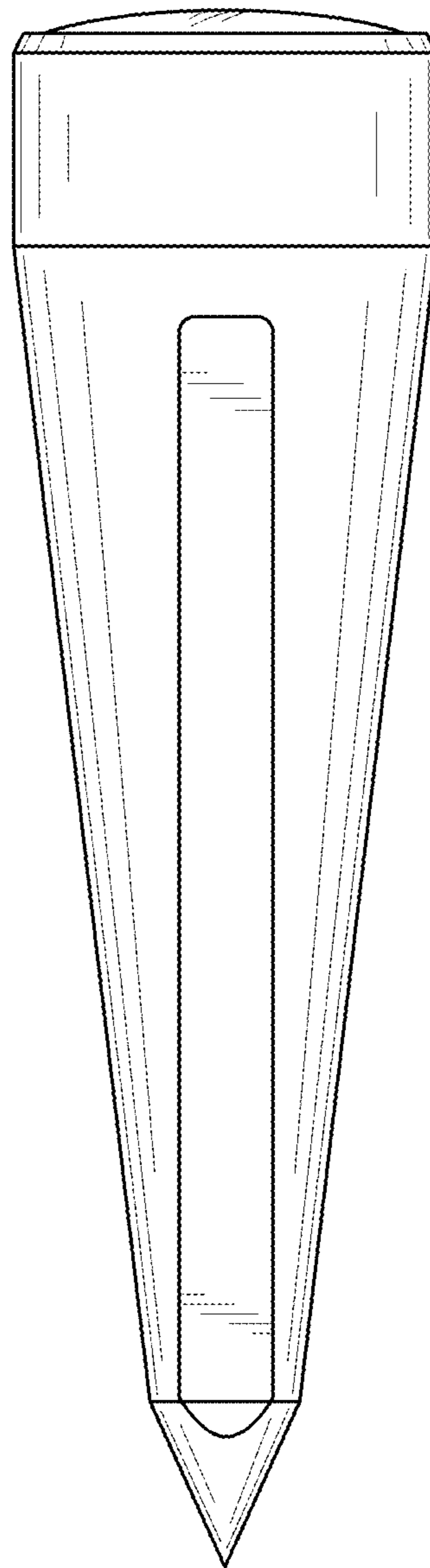

FIG. 9

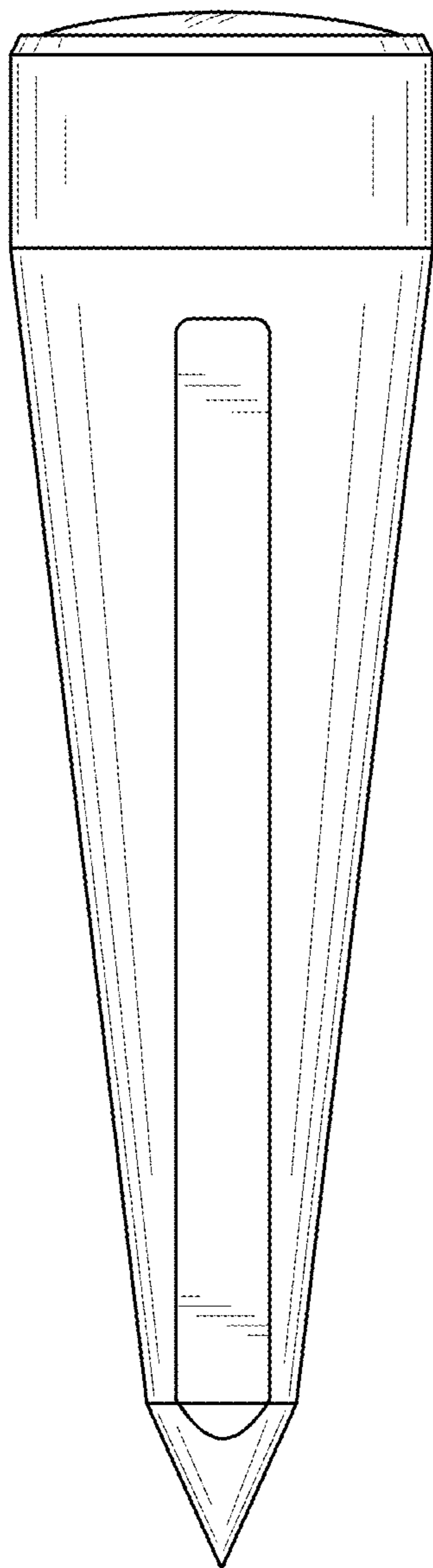

FIG. 10

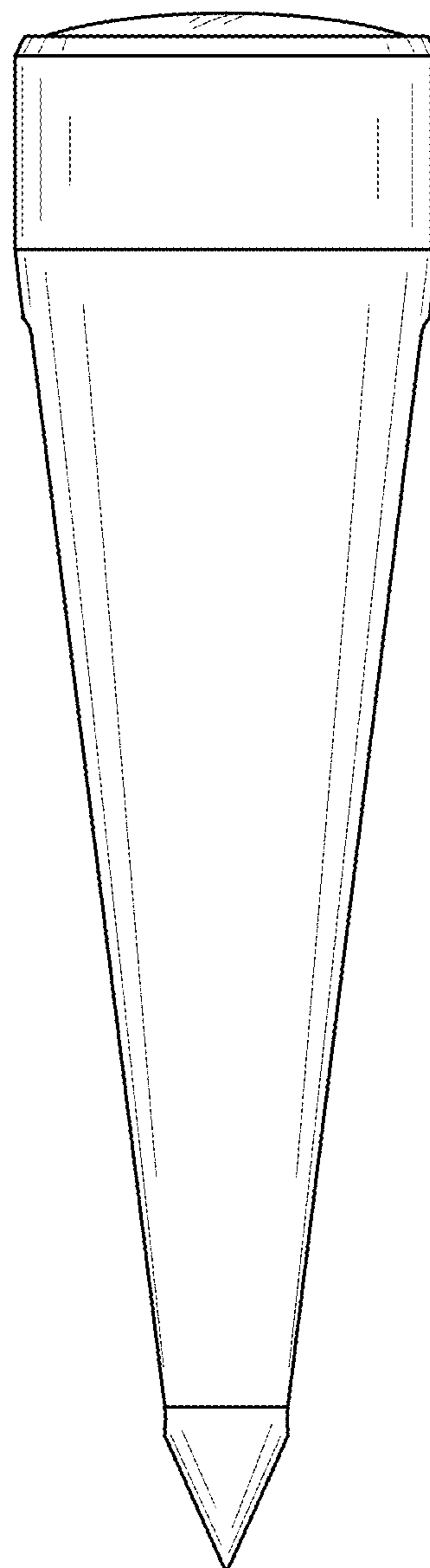

FIG. 11

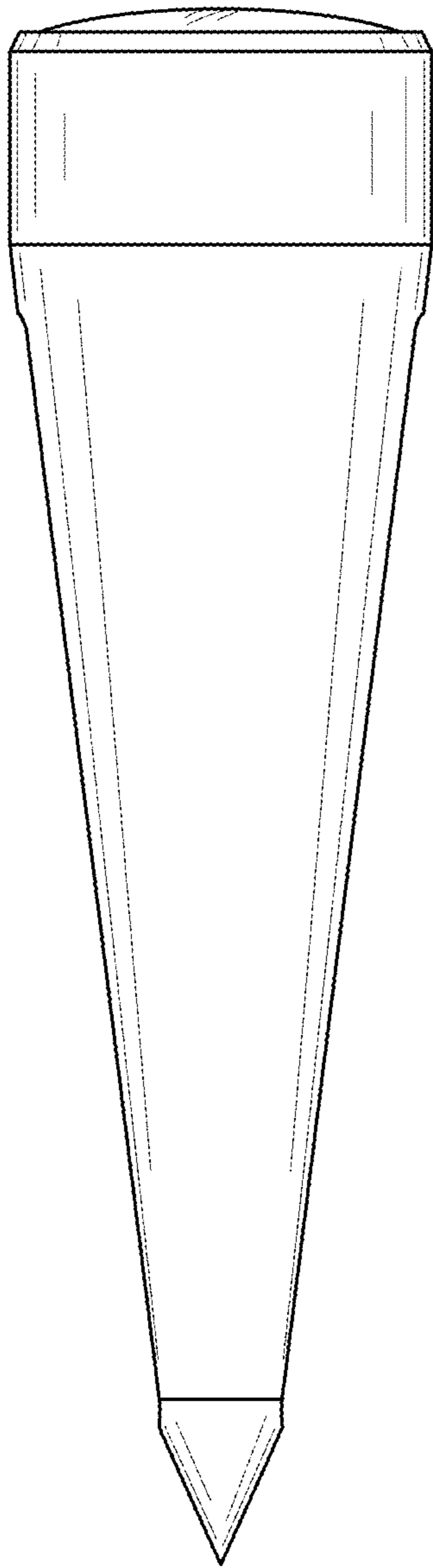

FIG. 12

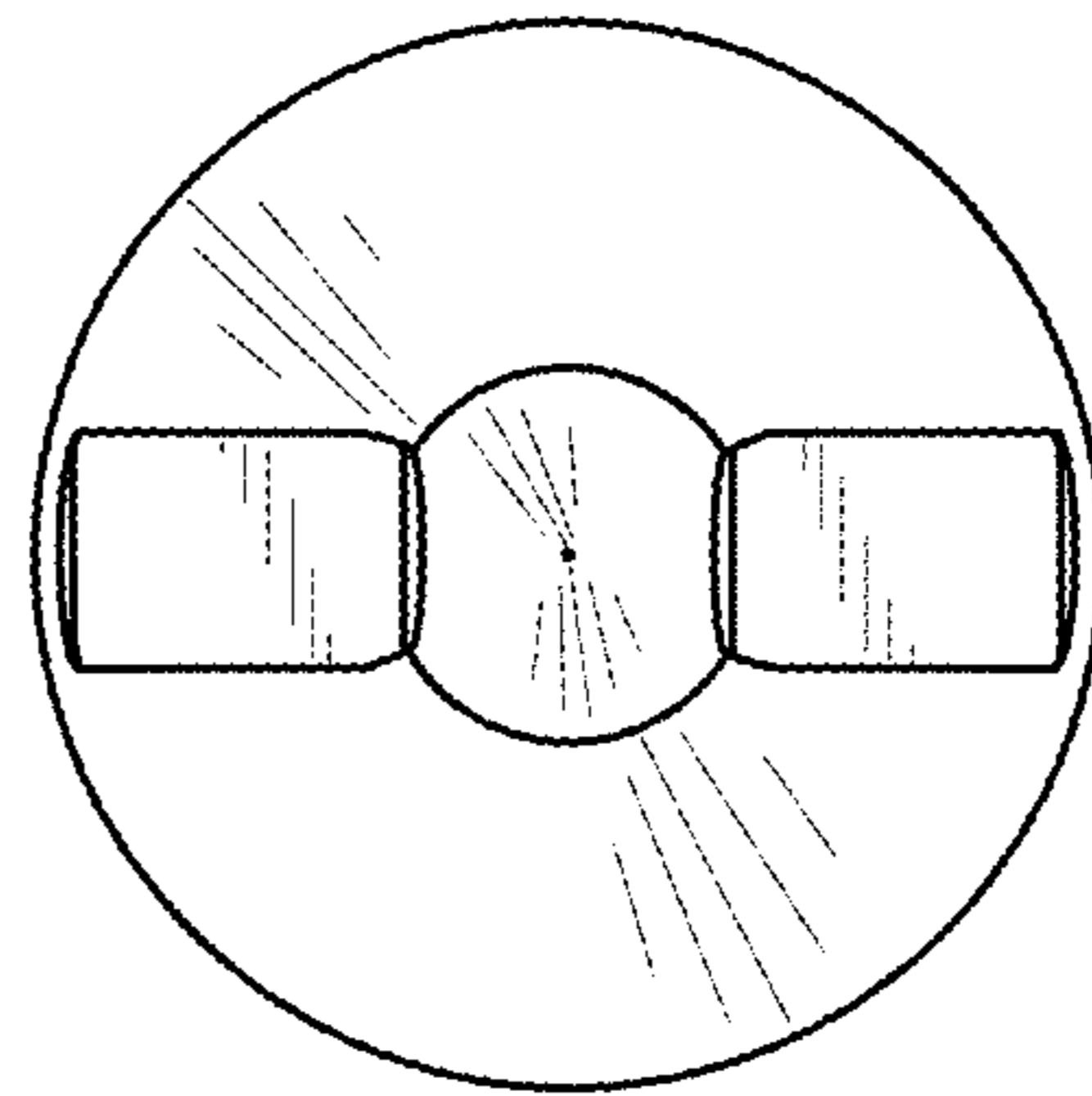

FIG. 13

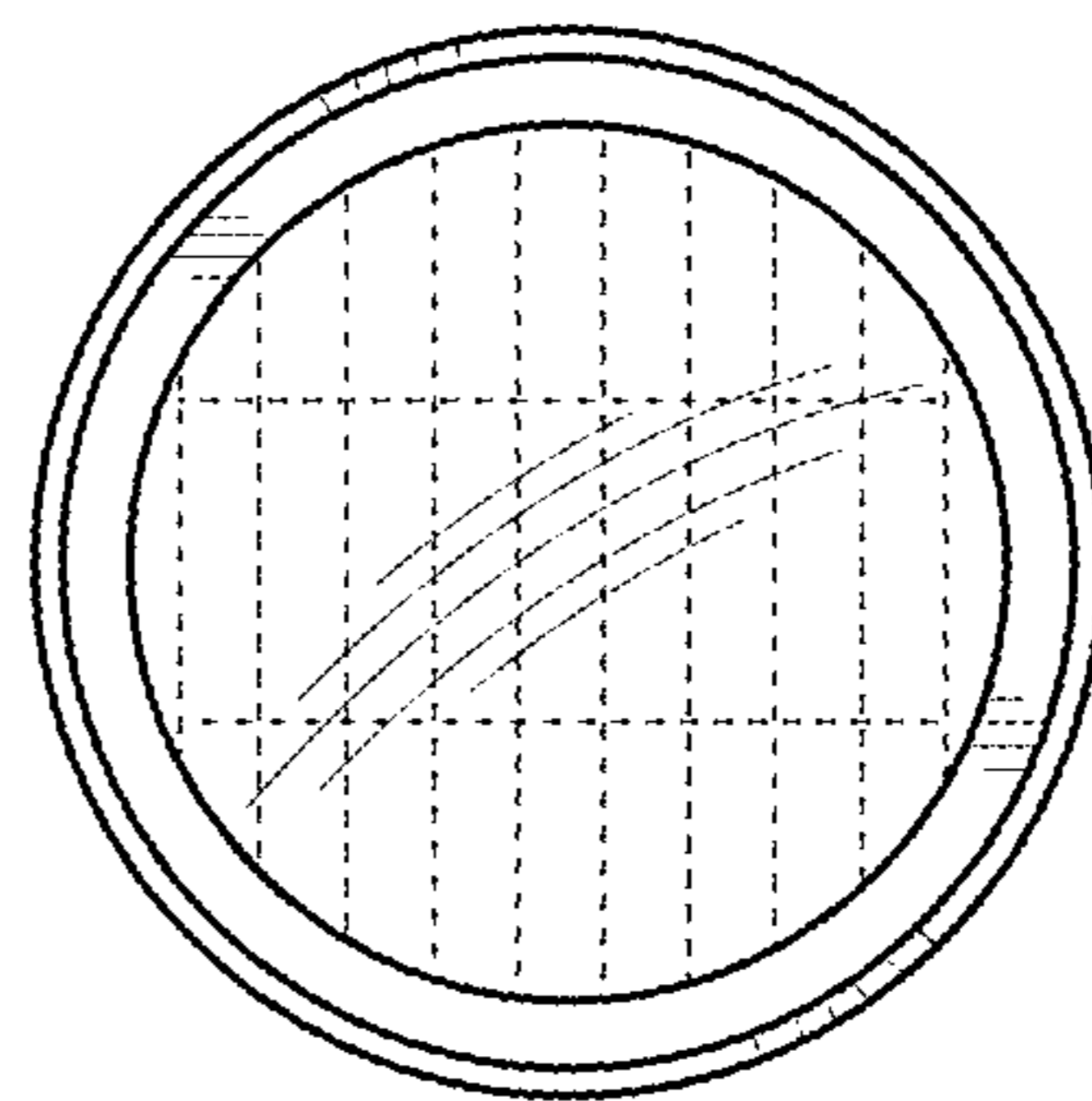

FIG. 14