



US00D974133S

(12) **United States Design Patent**  
**Galloni**

(10) **Patent No.:** **US D974,133 S**

(45) **Date of Patent:** **\*\* Jan. 3, 2023**

(54) **CENTER-LOCK SOCKET FOR AN IMPACT WRENCH**

(71) Applicant: **DINO PAOLI S.R.L.**, Reggio Emilia (IT)

(72) Inventor: **Federico Galloni**, Reggio Emilia (IT)

(73) Assignee: **DINO PAOLI S.R.L.**

(\*\*) Term: **15 Years**

(21) Appl. No.: **29/725,019**

(22) Filed: **Feb. 21, 2020**

(51) **LOC (14) Cl.** ..... **08-05**

(52) **U.S. Cl.**  
USPC ..... **D8/29**

(58) **Field of Classification Search**  
USPC ... D8/16, 17, 18, 19, 21, 22, 25, 26, 28, 29,  
D8/397, 399; D24/133, 152, 155, 156  
(Continued)

(56) **References Cited**

**U.S. PATENT DOCUMENTS**

7,311,022 B2 \* 12/2007 Putney ..... 81/121.1  
D632,149 S \* 2/2011 Li ..... D8/29  
(Continued)

**FOREIGN PATENT DOCUMENTS**

EM 001883646 6/2011  
EM 005405008-0001 7/2018  
(Continued)

**OTHER PUBLICATIONS**

Dino Paoli SRL. (Feb. 7, 2019). #PaoliMotorsport—Dino Paoli Pit Stop [Video]. Retrieved: Dec. 17, 2021. YouTube. URL:<<https://www.youtube.com/watch?v=yPf234jlv3Q>>Retrieved: Dec. 17, 2021> (Year: 2019).\*

*Primary Examiner* — Rachel A. Voorhies

*Assistant Examiner* — Benjamin D. Wannemacher  
(74) *Attorney, Agent, or Firm* — Laubscher & Laubscher PC

(57) **CLAIM**

The ornamental design for a center-lock socket for an impact wrench, as shown and described.

**DESCRIPTION**

FIG. 1 is a front perspective view of a center-lock socket for an impact wrench according to a first embodiment of our invention;

FIG. 2 is a rear perspective view of the embodiment of FIG. 1;

FIG. 3 is a front elevation view of the embodiment of FIG. 1

FIG. 4 is a rear elevation view of the embodiment of FIG. 1;

FIG. 5 is a top plan view of the embodiment of FIG. 1;

FIG. 6 is a right side elevation view of the embodiment of FIG. 1;

FIG. 7 is a sectional view taken along line 7-7 of FIG. 6;

FIG. 8 is a partial enlarged view of the area labeled 8 in FIG. 3;

FIG. 9 is a partial enlarged view of the area labeled 9 in FIG. 7;

FIG. 10 is a front perspective view of a center-lock socket for an impact wrench according to a second embodiment of our invention;

FIG. 11 is a rear perspective view of the embodiment of FIG. 10;

FIG. 12 is a front elevation view of the embodiment of FIG. 10;

FIG. 13 is a rear elevation view of the embodiment of FIG. 10;

FIG. 14 is a top plan view of the embodiment of FIG. 10;

FIG. 15 is a right side elevation view of the embodiment of FIG. 10;

FIG. 16 is a sectional view taken along line 16-16 of FIG. 15;

FIG. 17 is a partial enlarged view of the area labeled 17 in FIG. 12; and,

(Continued)

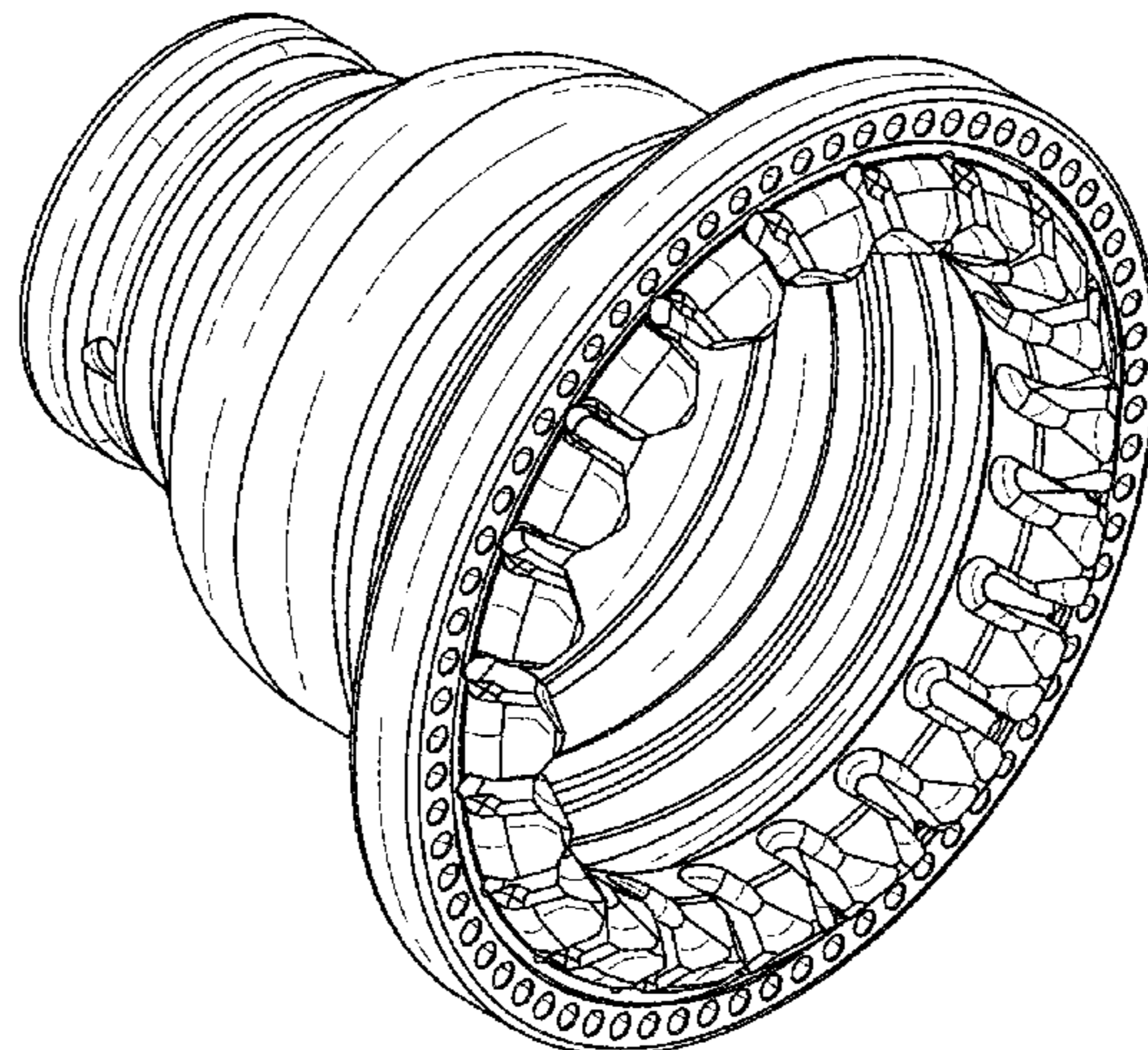

FIG. 18 is a partial enlarged view of the area labeled 18 in FIG. 16.

The tangent lines shown in the drawing are contour lines that delimit surfaces of different curvature and are not ornamental features of the design.

The dash-dash broken line circles of FIGS. 3, 7, 8, 9, 12, 16, 17, and 18 depict the limits of the enlarged views and form no part of the claimed design. The dash-dash lead lines in FIGS. 3, 7, 12, and 16 labeled 8, 9, 17 and 18, respectively, indicate the areas from which the enlargement in FIGS. 3, 7, 12, and 16 are taken and form no part of the claimed design.

**1 Claim, 18 Drawing Sheets**

(58) **Field of Classification Search**

CPC ..... B25B 13/08; B25B 13/46; B25B 13/462;  
 B25B 13/481; B25B 13/461; B25B 13/48;  
 B25B 13/56; B25B 13/16; B25B 13/463;  
 B25B 21/004; B25B 23/1425; B25B  
 23/16; B25B 23/0035; B25B 23/00

See application file for complete search history.

(56)

**References Cited**

U.S. PATENT DOCUMENTS

D684,028	S	6/2013	Costoli	
D709,744	S *	7/2014	Kluhsman, Jr. ....	B25B 13/065 D8/29
D761,630	S *	7/2016	Li .....	D8/29
D853,217	S	7/2019	Paoli	
D853,808	S *	7/2019	Hyma .....	D8/29
D871,875	S	1/2020	Paoli	
2014/0060260	A1 *	3/2014	Kluhsman, Jr. ....	B25B 13/065 81/121.1
2017/0312892	A1 *	11/2017	von Tardy-Tuch ....	B25B 23/10 D8/29

FOREIGN PATENT DOCUMENTS

EM	005405008-0002	7/2018
EM	007146774-0001	10/2019
EM	007146774-0002	10/2019
EM	007146774-0003	10/2019

\* cited by examiner

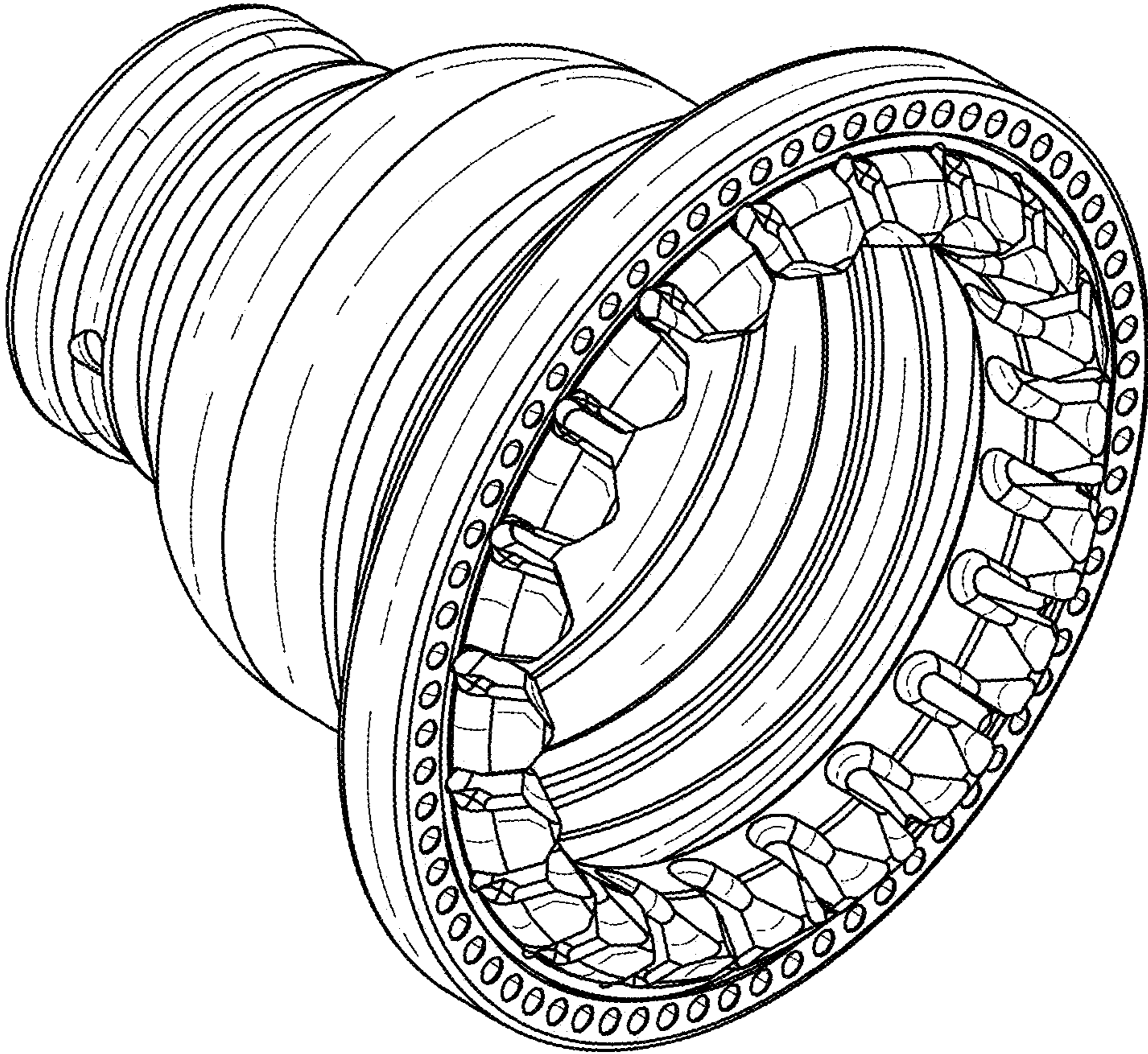

FIG. 1

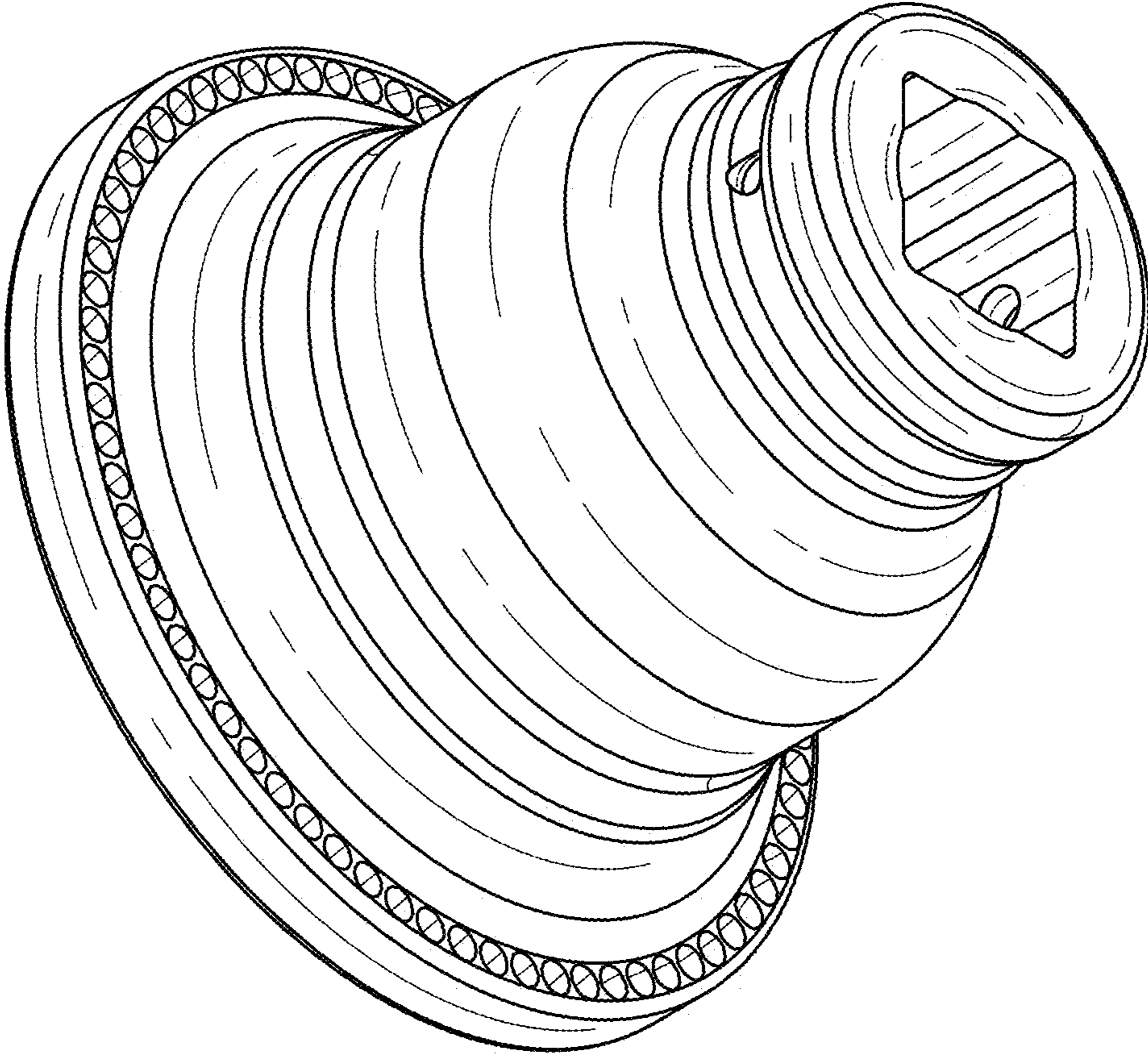

FIG. 2

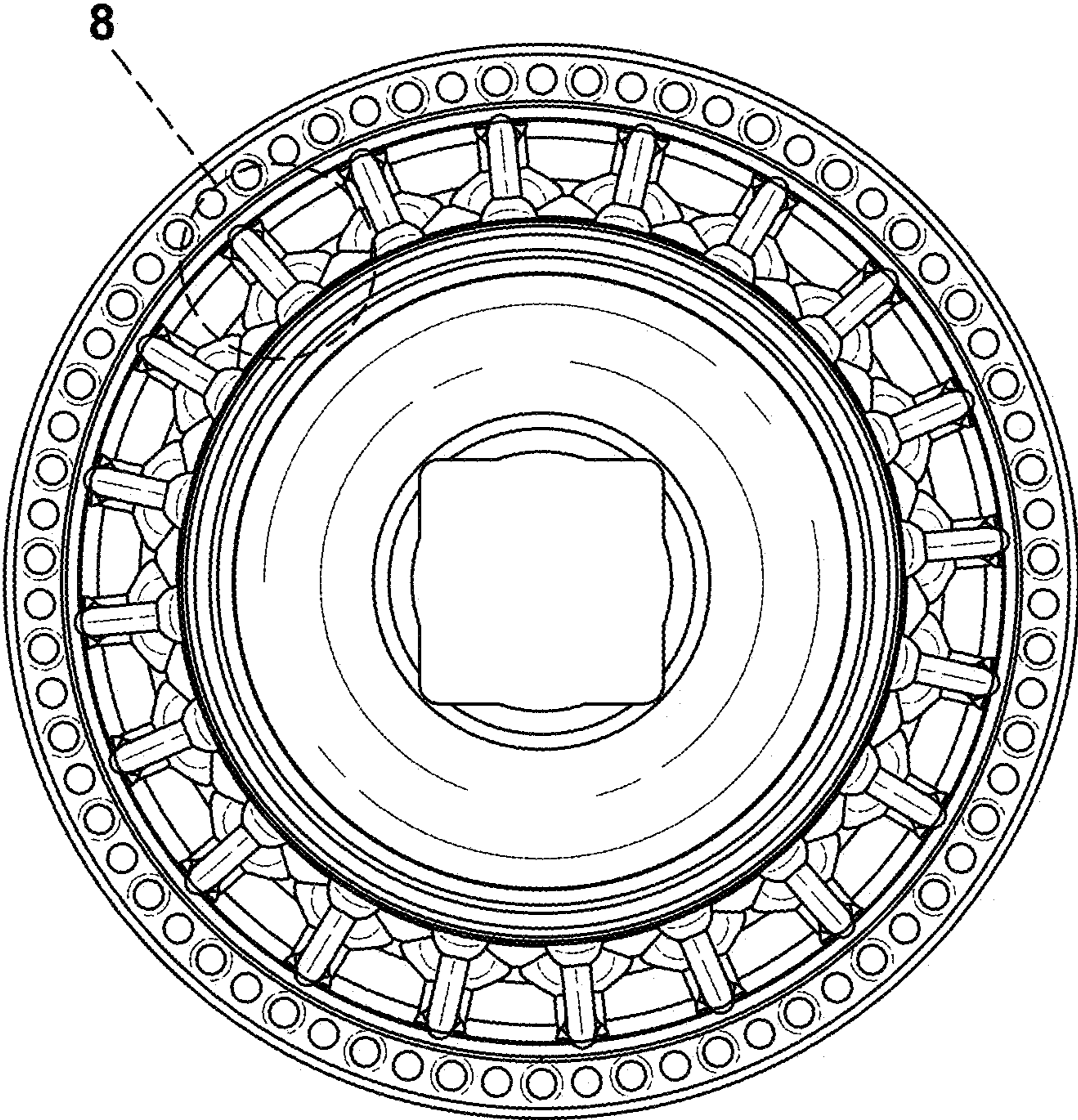

FIG. 3

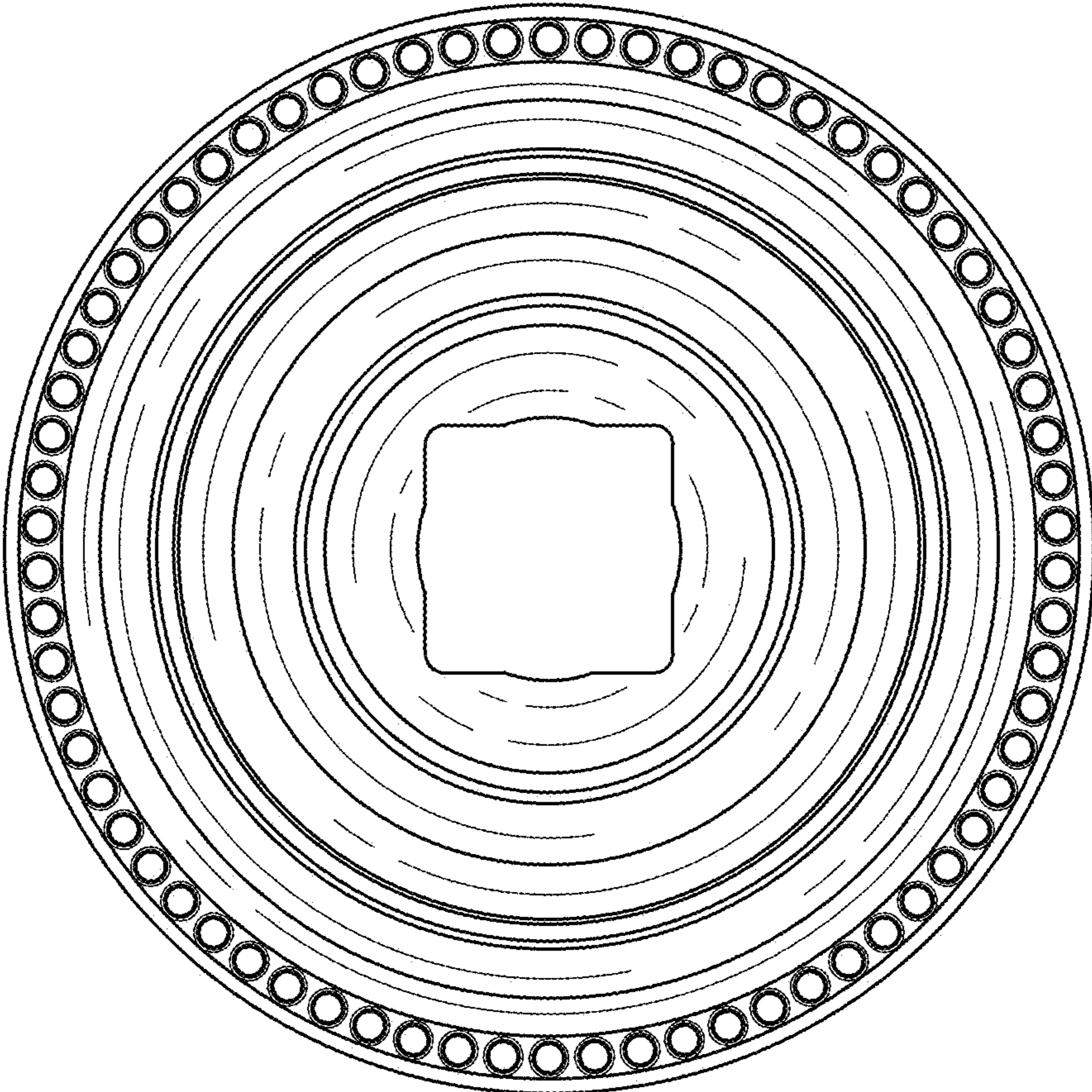

FIG. 4

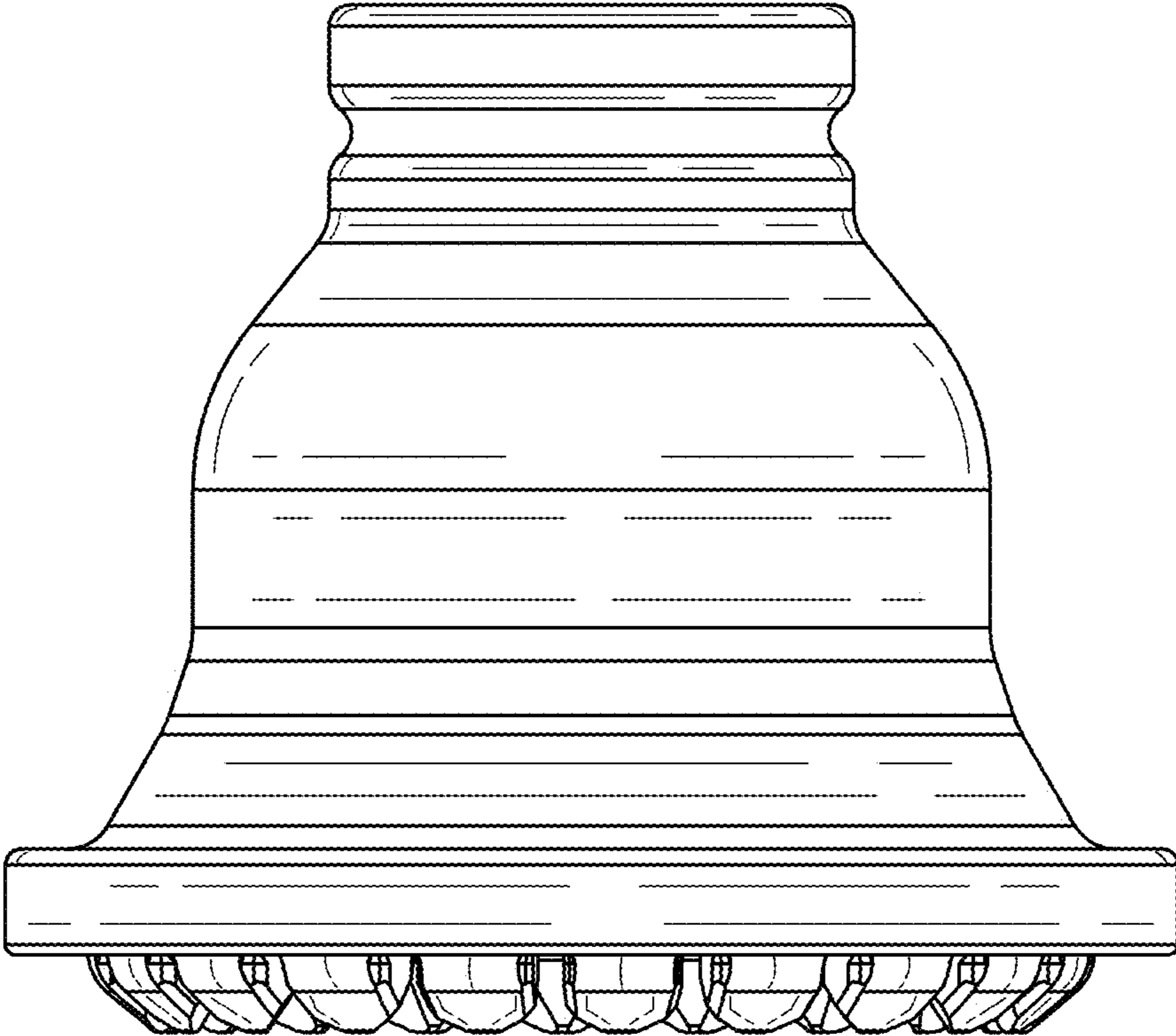

FIG. 5

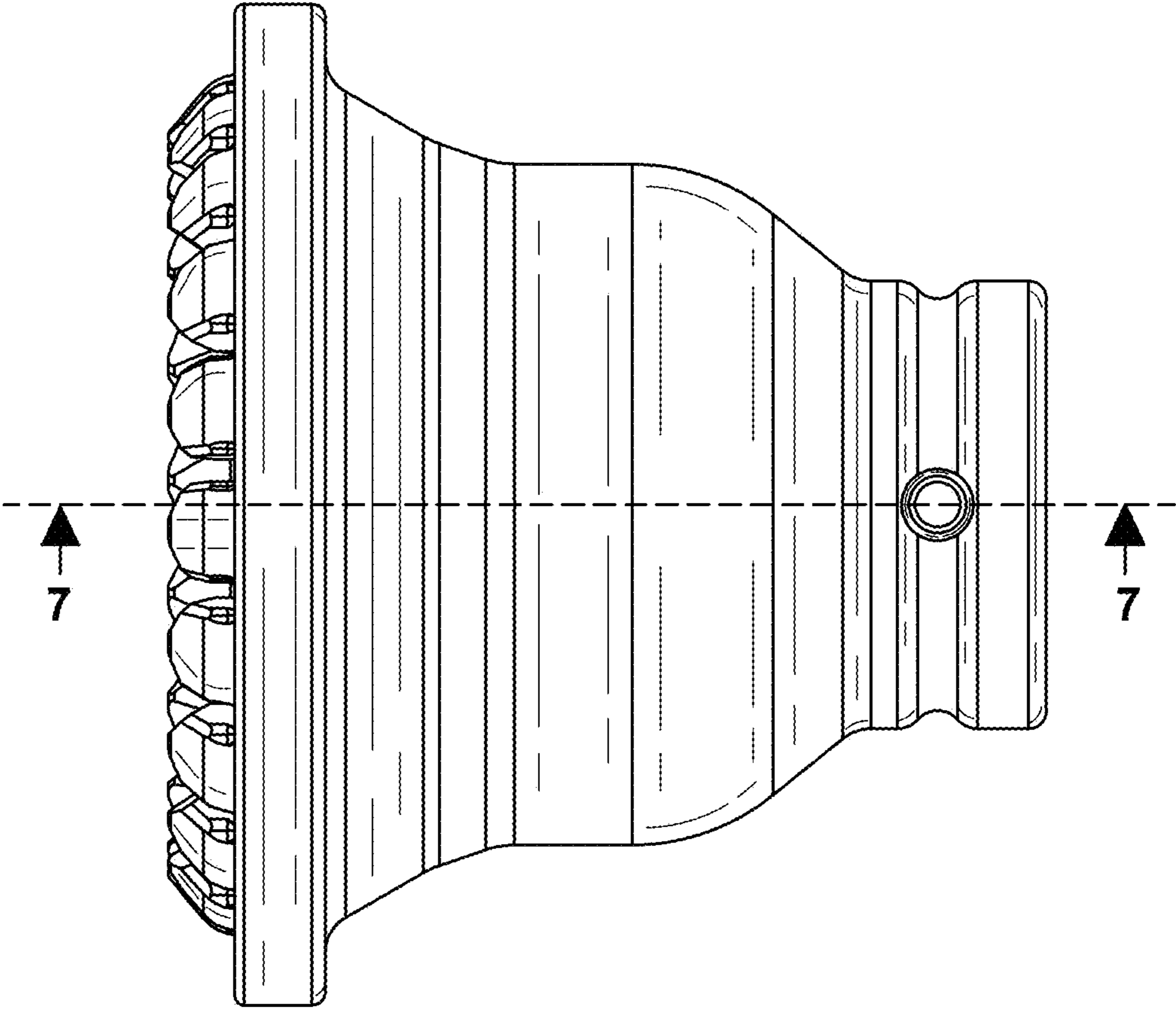

FIG. 6



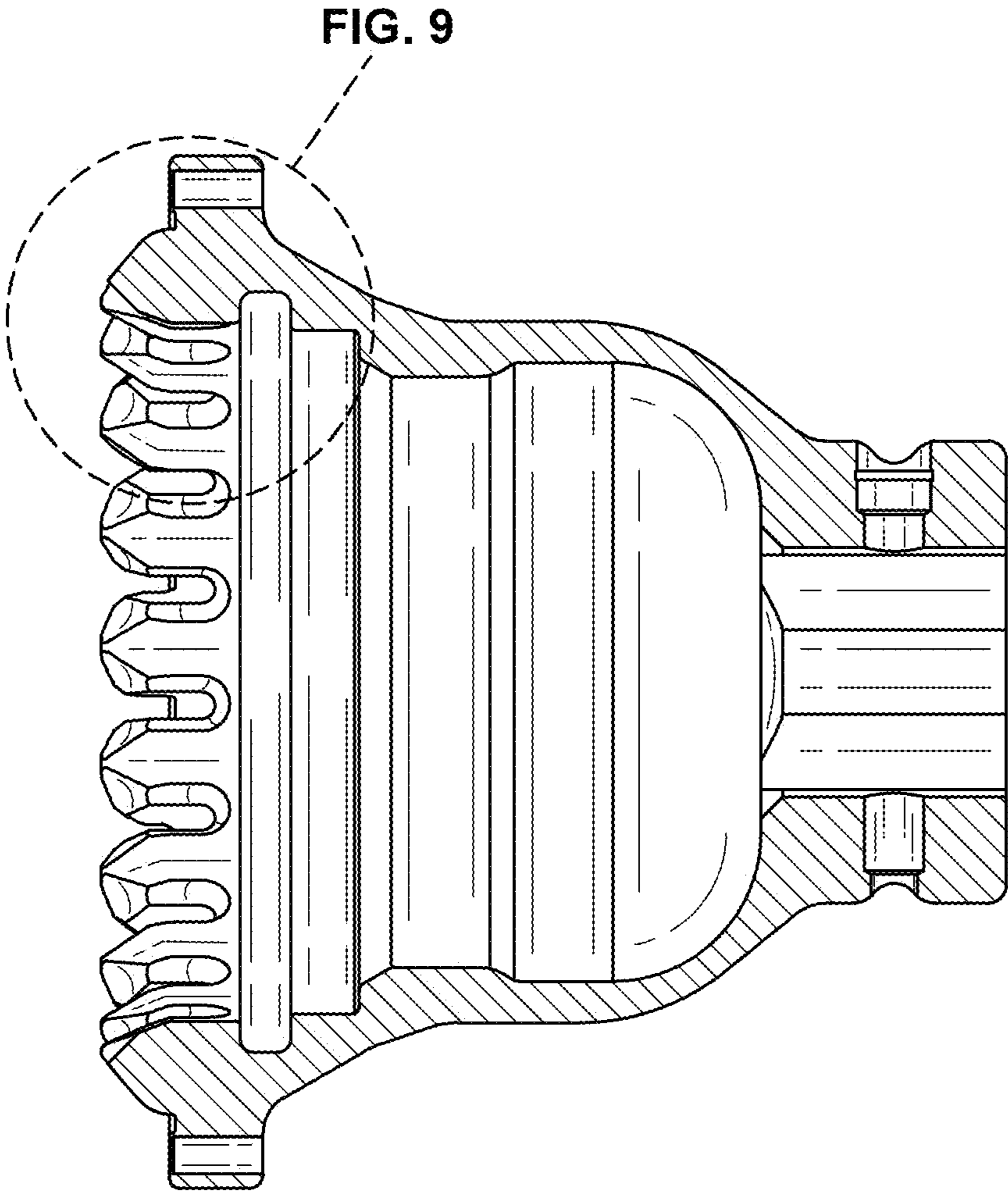

FIG. 7

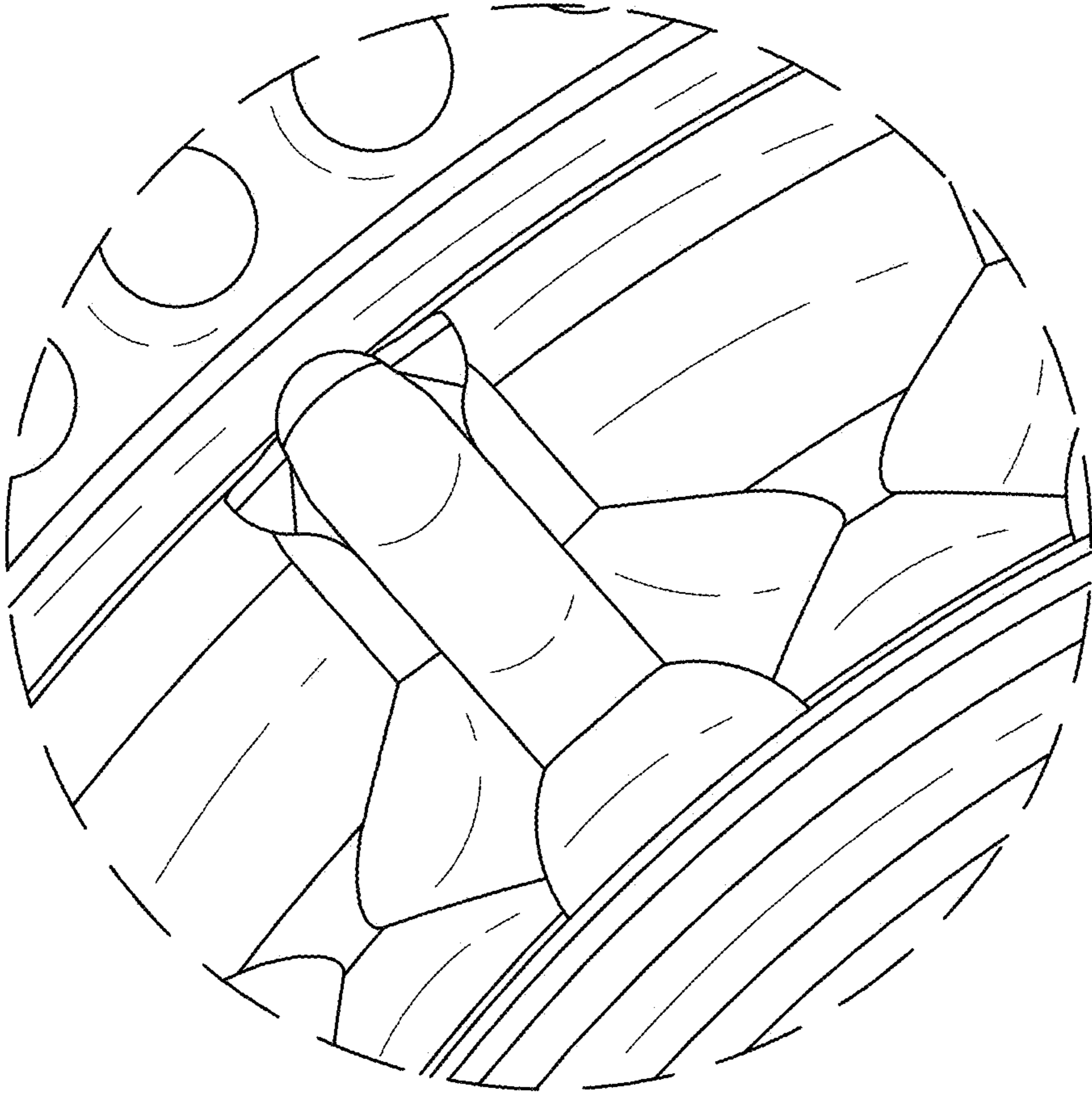

FIG. 8

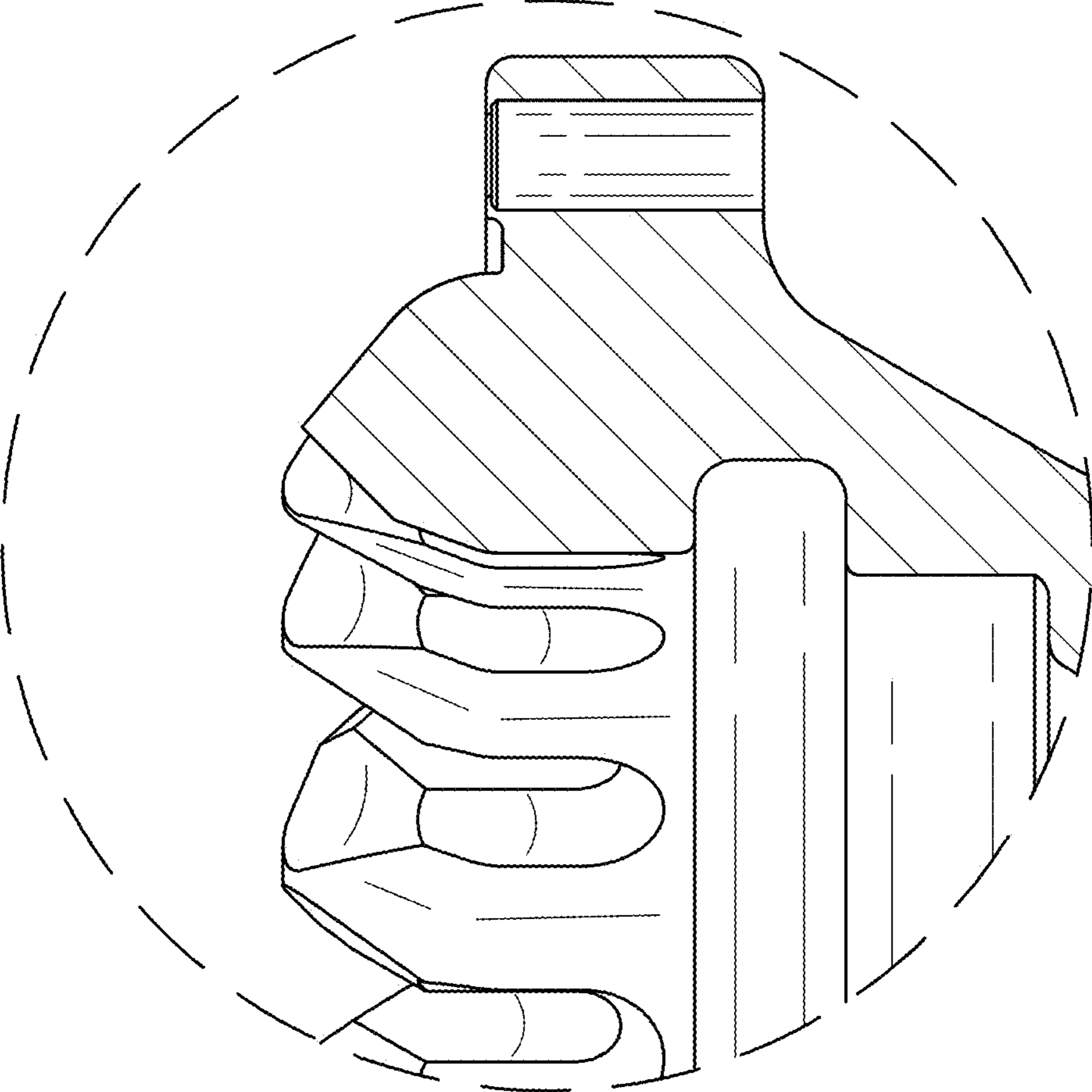

FIG. 9

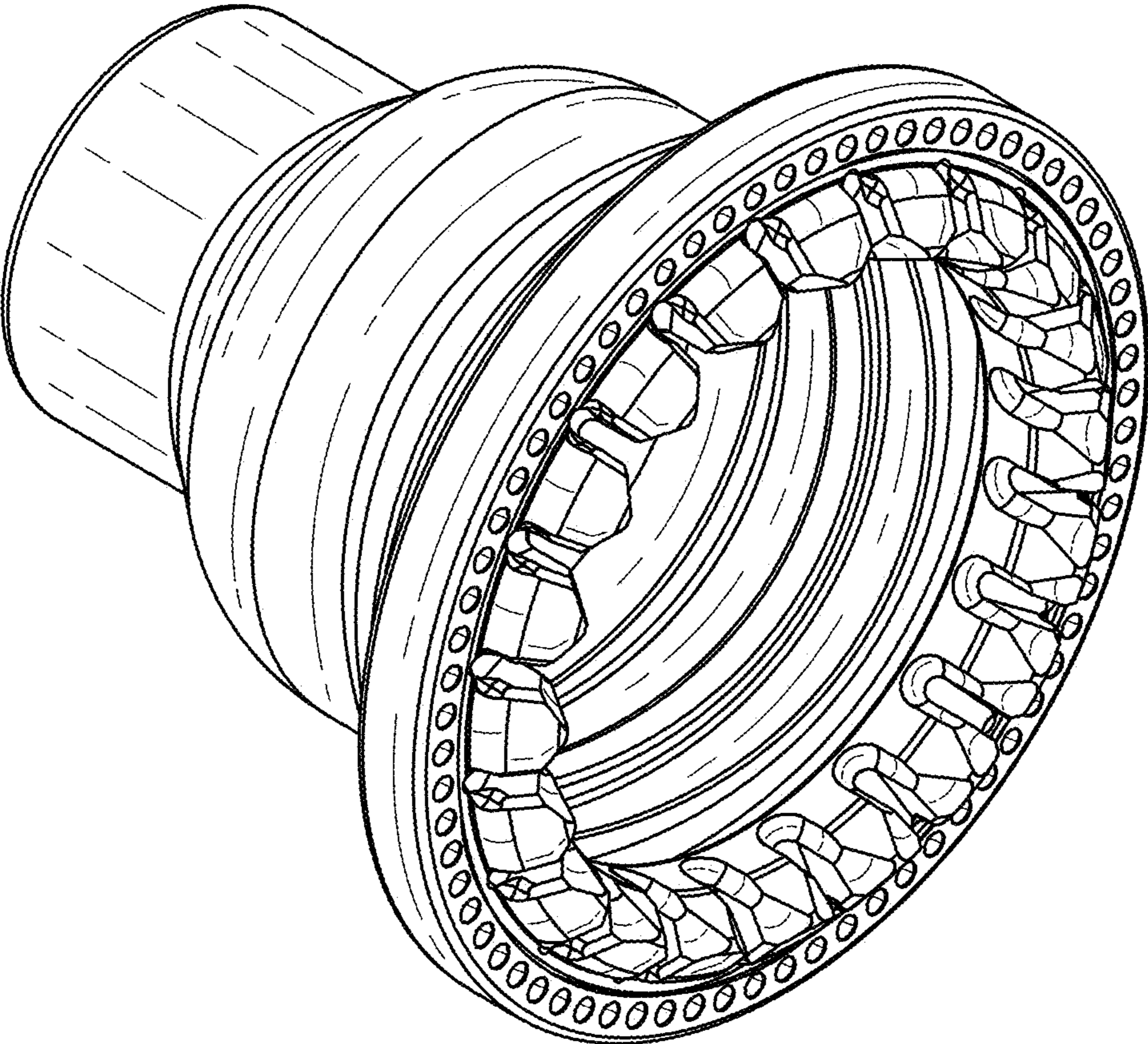

FIG. 10

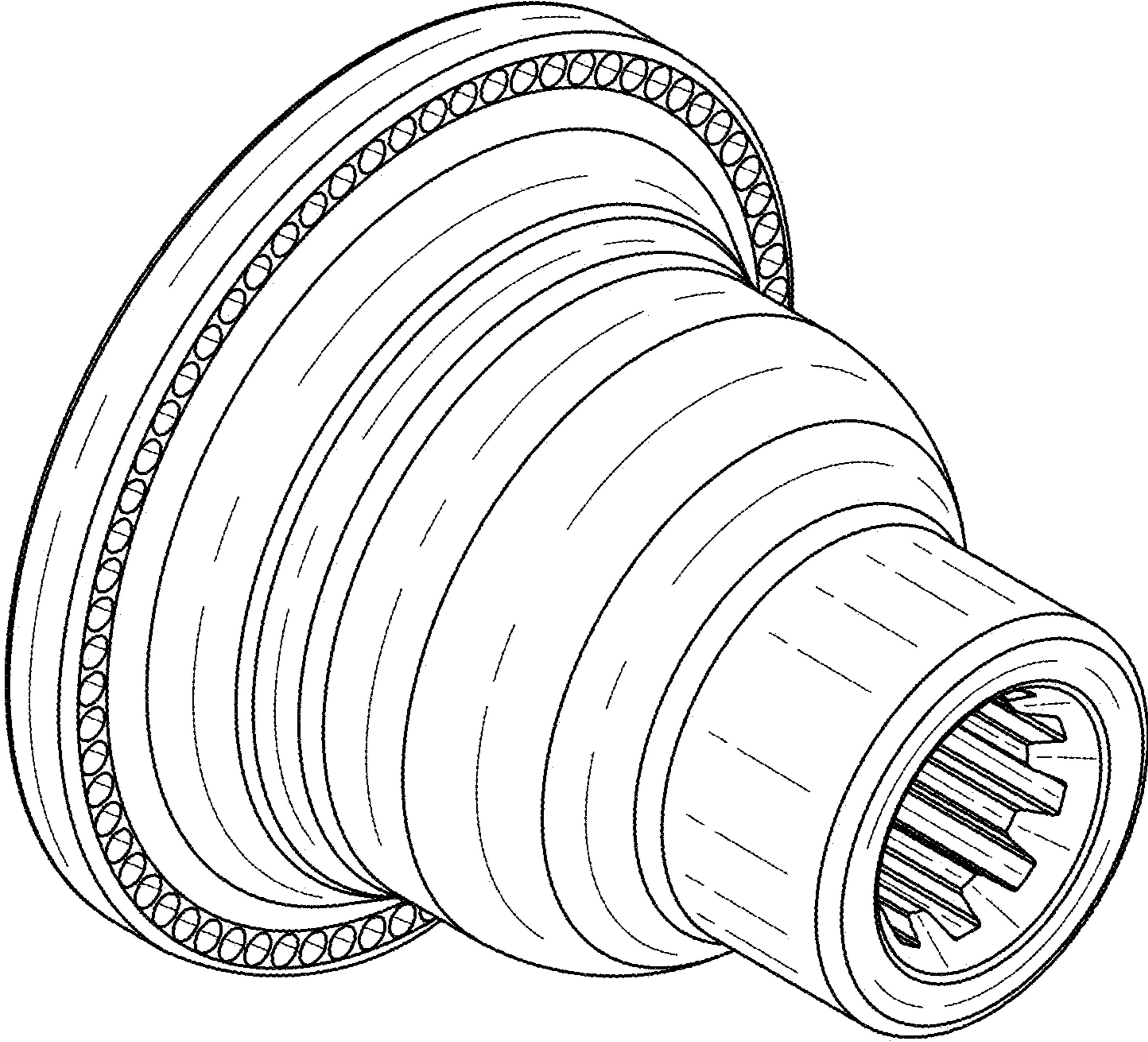

FIG. 11

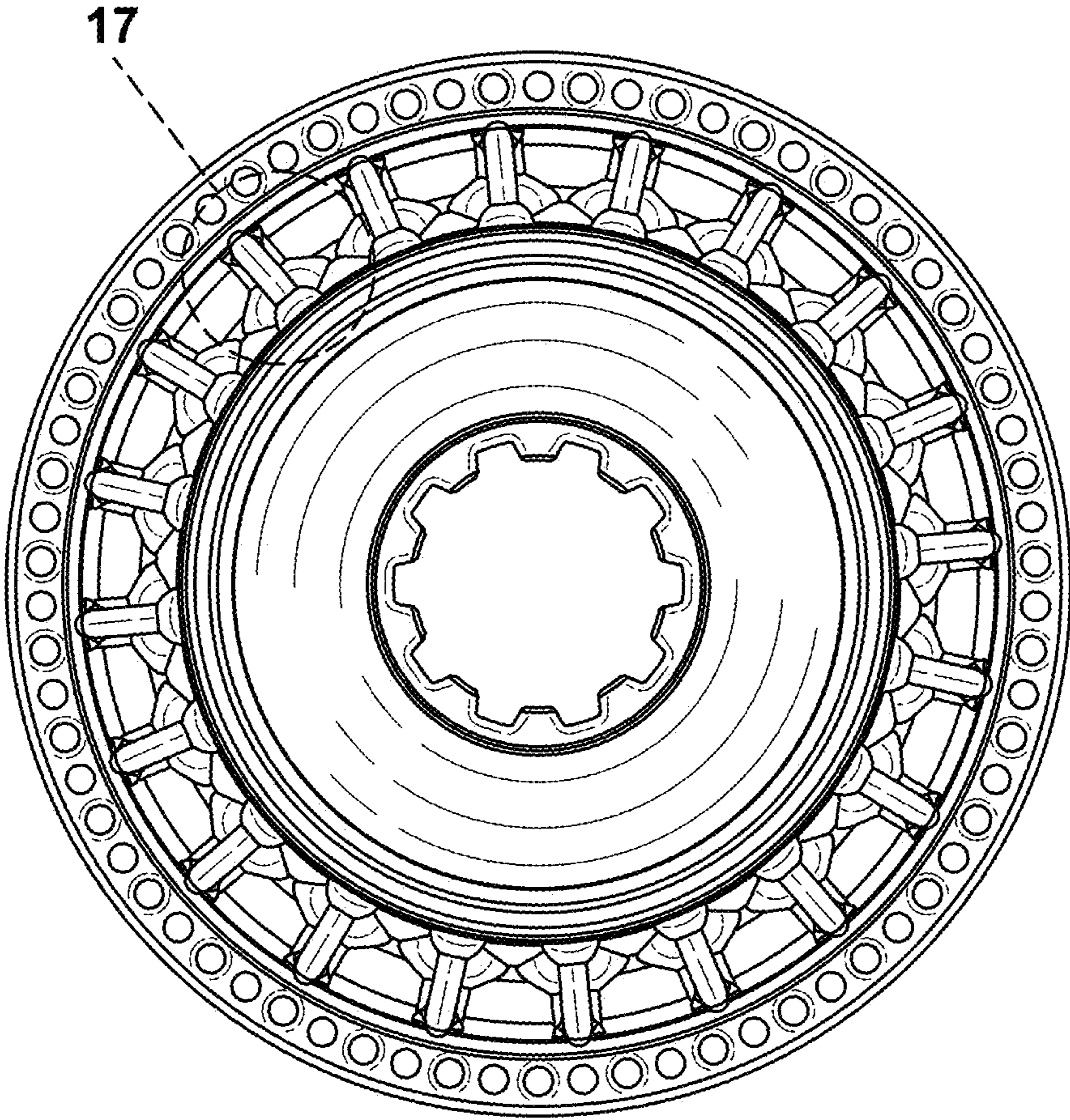

FIG. 12

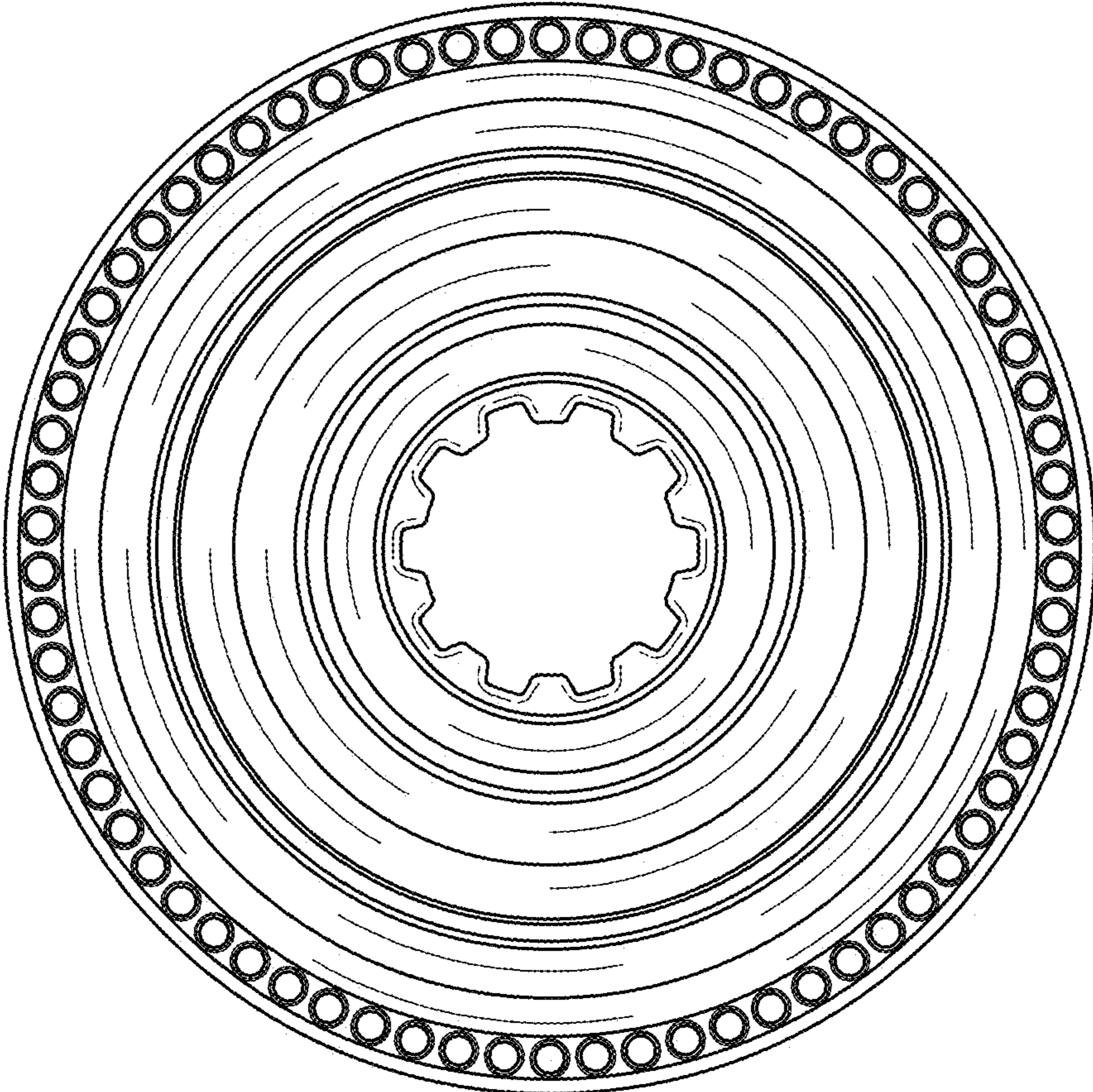

FIG. 13

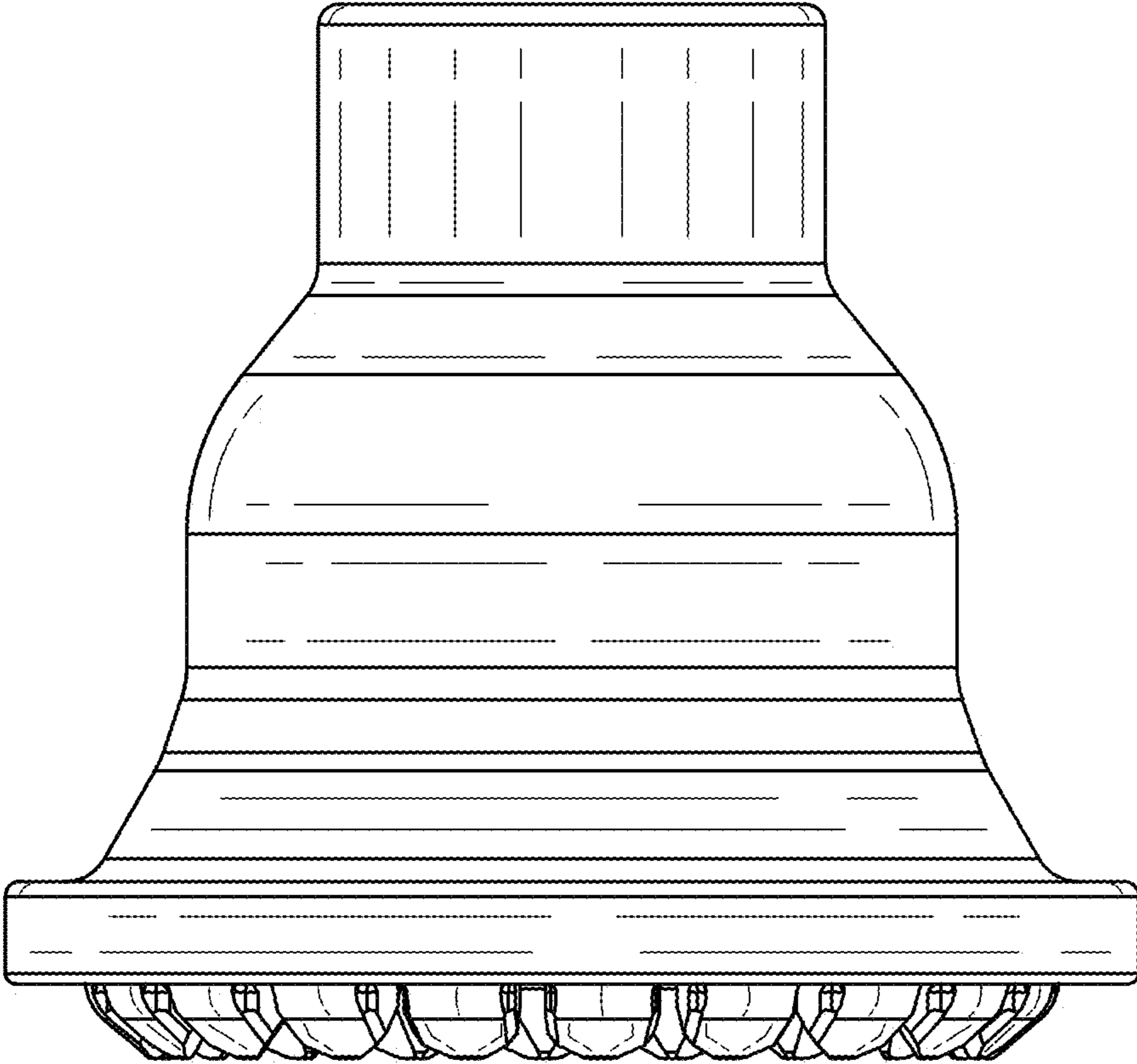

FIG. 14



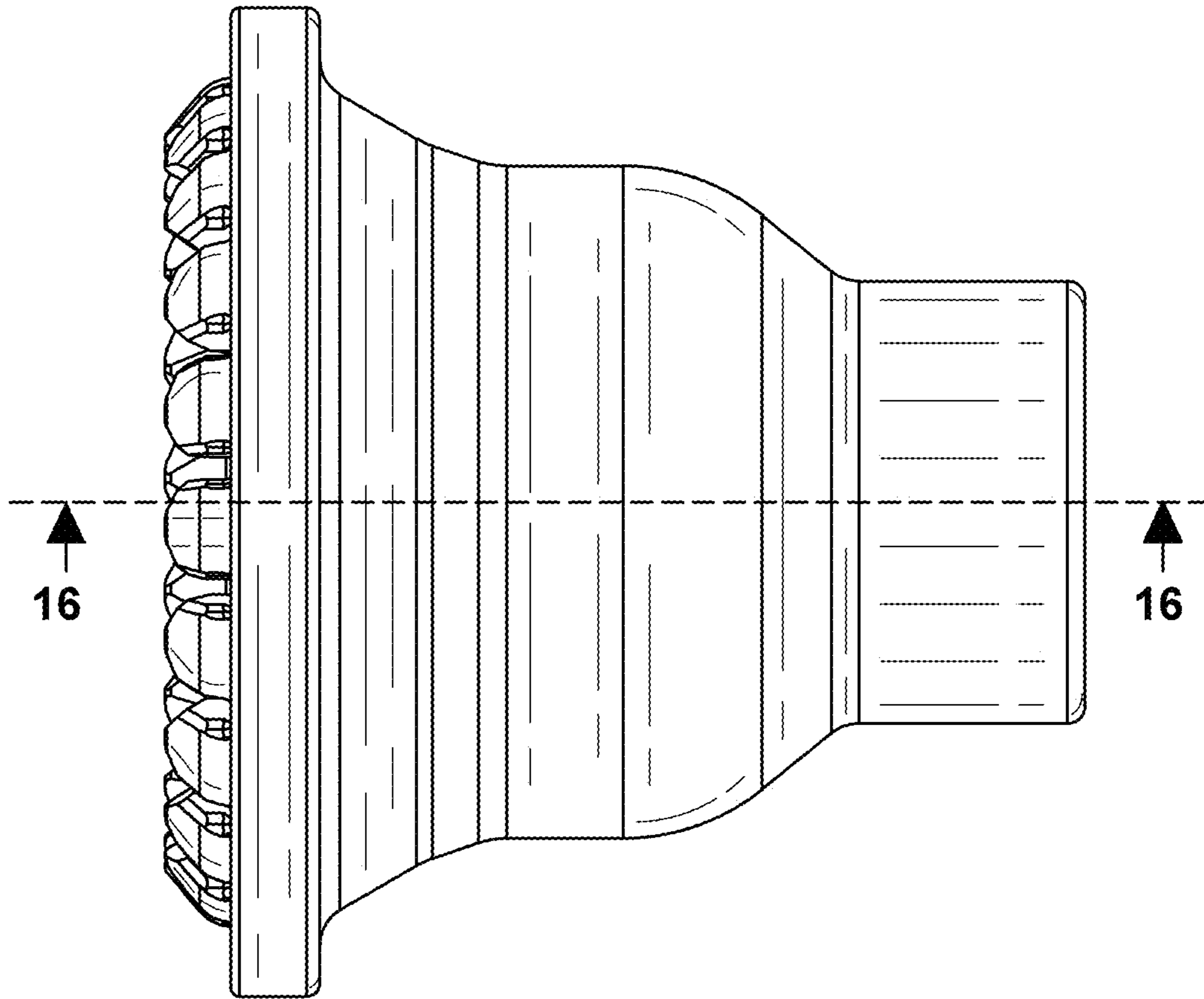
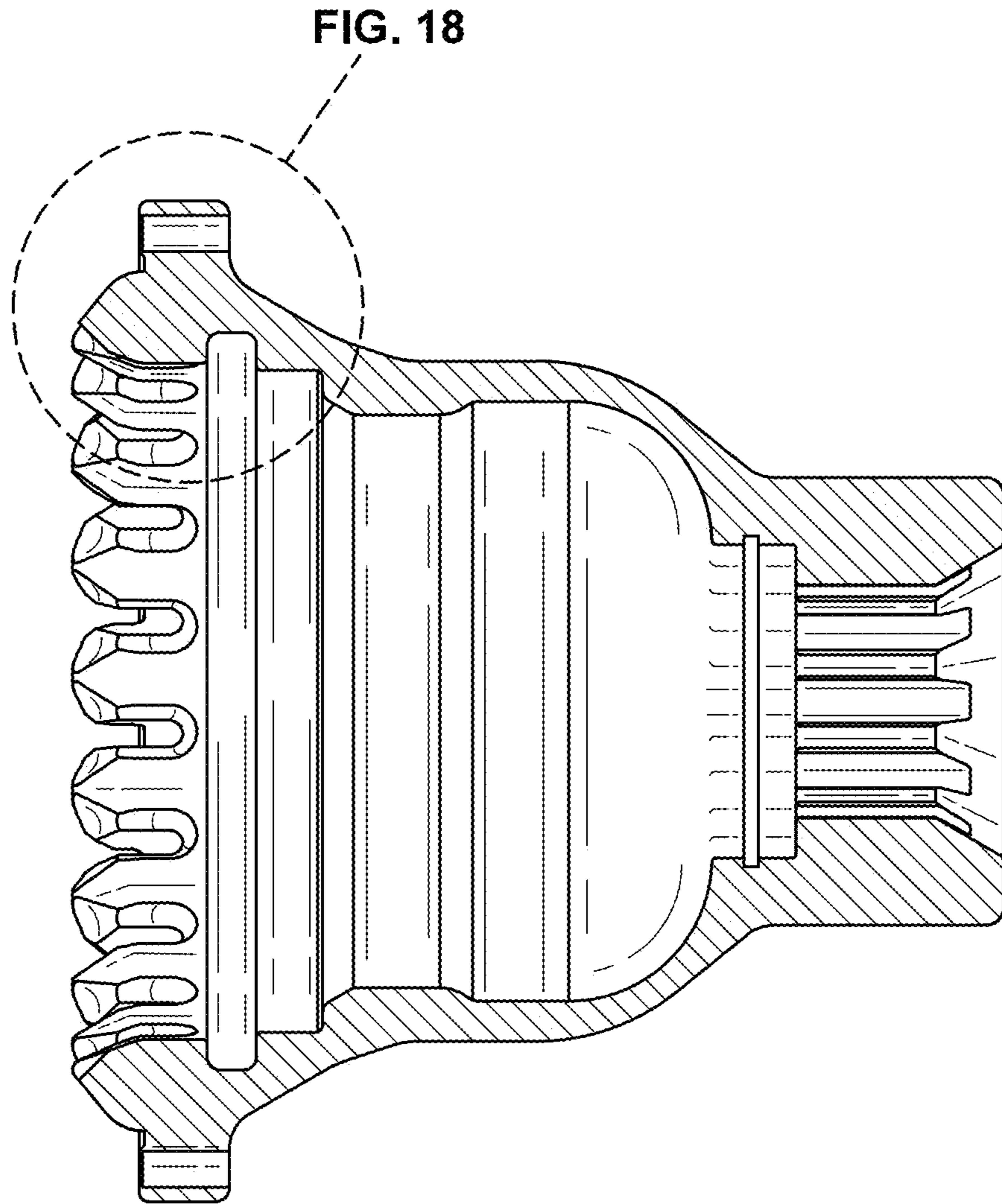

FIG. 15



**FIG. 16**

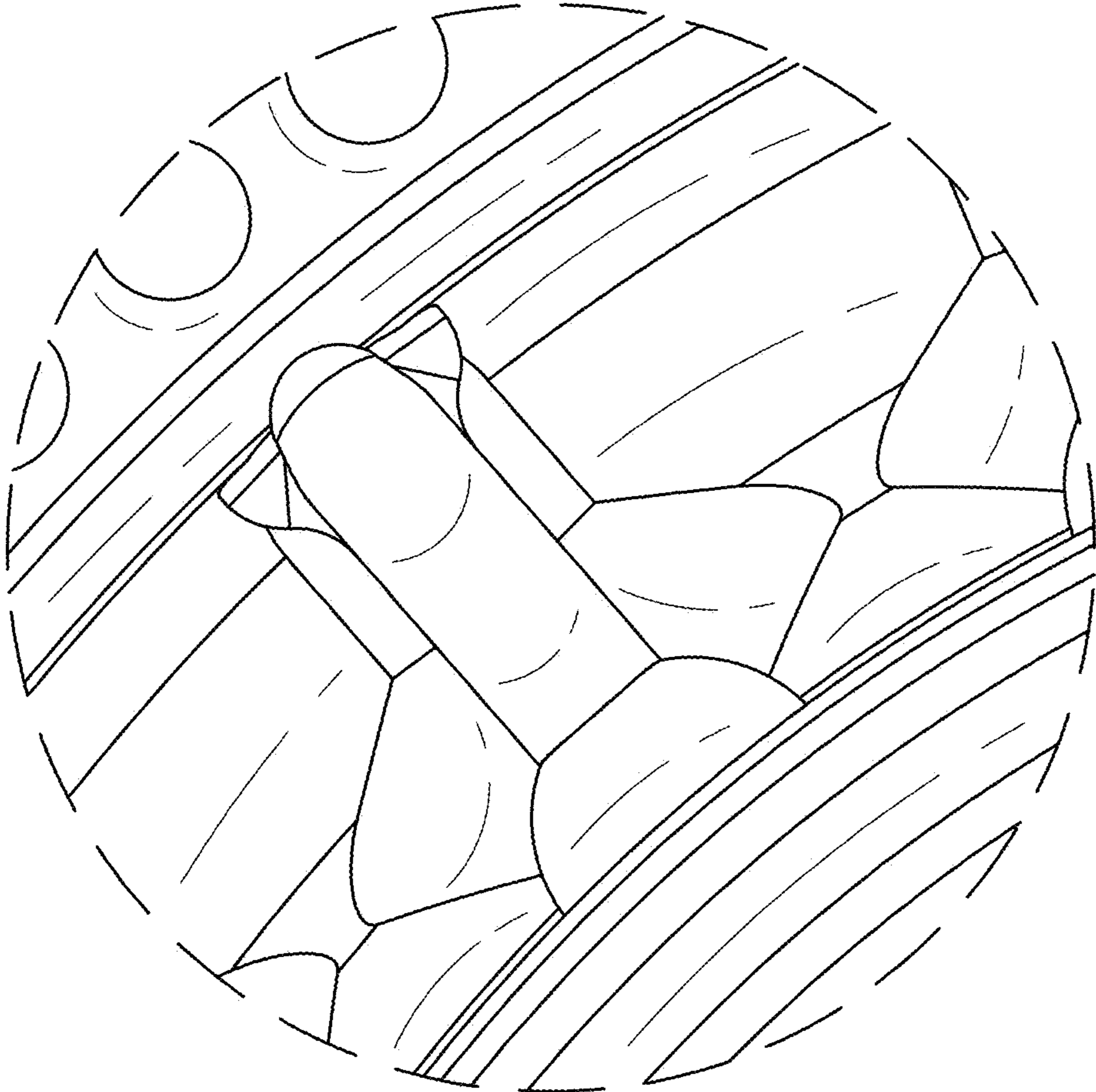

FIG. 17

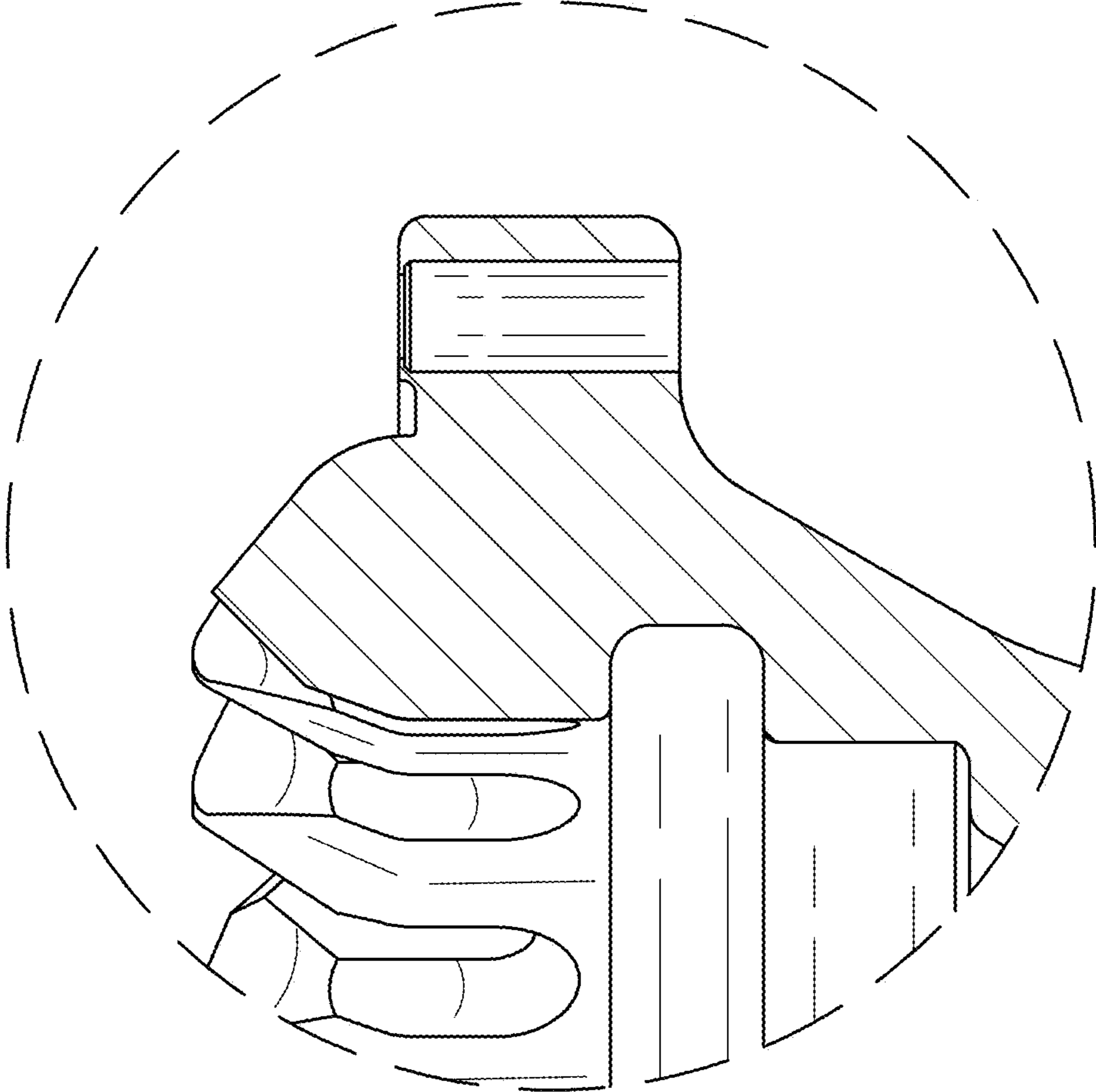

FIG. 18