



US00D974130S

(12) **United States Design Patent** (10) **Patent No.:** **US D974,130 S**  
**Haskins** (45) **Date of Patent:** **\*\* Jan. 3, 2023**

(54) **LUNCH BAG**  
(71) Applicant: **Real Value LLC**, Norman, OK (US)  
(72) Inventor: **Nathaniel Haskins**, Oklahoma City, OK (US)  
(73) Assignee: **Real Value LLC**, Moore, OK (US)  
(\*\*) Term: **15 Years**  
(21) Appl. No.: **29/706,393**  
(22) Filed: **Sep. 19, 2019**  
(51) **LOC (14) Cl.** ..... **07-02**  
(52) **U.S. Cl.**  
USPC ..... **D7/709; D7/607**  
(58) **Field of Classification Search**  
USPC ..... D7/601, 602, 605, 607, 701, 703, 705,  
D7/706, 709, 629; D3/201, 232, 233,  
D3/245, 246, 273, 276, 301  
CPC ..... A45C 1/00; A45C 11/20; A45C 2003/007;  
A45C 2003/008; A45C 7/0059; F25D  
2331/80; F25D 2331/804; B65D 30/08  
See application file for complete search history.

D926,469 S \* 8/2021 Barlier ..... D3/283  
2011/0167863 A1 \* 7/2011 Herrbold ..... F25D 3/08  
62/457.1  
2016/0338462 A1 \* 11/2016 Hayashi ..... A45C 3/06

**OTHER PUBLICATIONS**

Simple Modern Lunch Bag | posted at Amazon.com, posted on May 2, 2019, © 1996-2021 Amazon.com, [online], [site visited Sep. 24, 2021]. Available from Internet, <URL:https://www.amazon.com/Simple-Modern-Very-Lunch-Women/dp/B07RJ7SXLB/> (Year: 2019).\*

Baloray Lunch Bag | posted at Amazon.com, posted on Oct. 15, 2015, © 1996-2022 Amazon.com, [online], [site visited Apr. 8, 2022]. Available from Internet, <URL: https://www.amazon.com/dp/B016NTJK2A?pd\_rd\_i=B016NTJK2A&pd\_rd\_w=HCT2u&pf> (Year: 2015).\*

\* cited by examiner

*Primary Examiner* — Andrew Kerr

(74) *Attorney, Agent, or Firm* — Hall Estill Law Firm

(57) **CLAIM**

The ornamental design for a lunch bag, as shown and described.

**DESCRIPTION**

FIG. 1 is a back view of a lunch bag, showing my new design.

FIG. 2 is a back view of the lunch bag of FIG. 1.

FIG. 3 is a left side view of the lunch bag of FIG. 1.

FIG. 4 is a right side view of the lunch bag of FIG. 1.

FIG. 5 is a top view of the lunch bag of FIG. 1; and,

FIG. 6 is a bottom view of the lunch bag of FIG. 1.

The evenly spaced broken lines on the lunch bag in FIGS. 1-5 represent stitching. The remainder of the broken lines in the drawing views depict portions that form no part of the claimed design.

**1 Claim, 6 Drawing Sheets**

(56) **References Cited**

**U.S. PATENT DOCUMENTS**

D115,063 S \* 5/1939 Cohen ..... D3/246  
D531,405 S \* 11/2006 Tortorella ..... D3/246  
D560,069 S \* 1/2008 Greiner ..... D3/246  
D609,470 S \* 2/2010 Guyon ..... D3/245  
D632,480 S \* 2/2011 LaCorte ..... D3/232  
D724,836 S \* 3/2015 Thai ..... D3/232  
9,139,352 B2 \* 9/2015 Seiders ..... A45C 11/20  
D756,634 S \* 5/2016 Bonstrom ..... D3/243  
D780,524 S \* 3/2017 Jacobsen ..... D7/607  
D803,563 S \* 11/2017 Leblanc ..... D3/289  
D821,744 S \* 7/2018 Armani ..... D3/232  
D883,047 S \* 5/2020 Kou ..... D7/709  
D883,753 S \* 5/2020 Zheng ..... D7/607

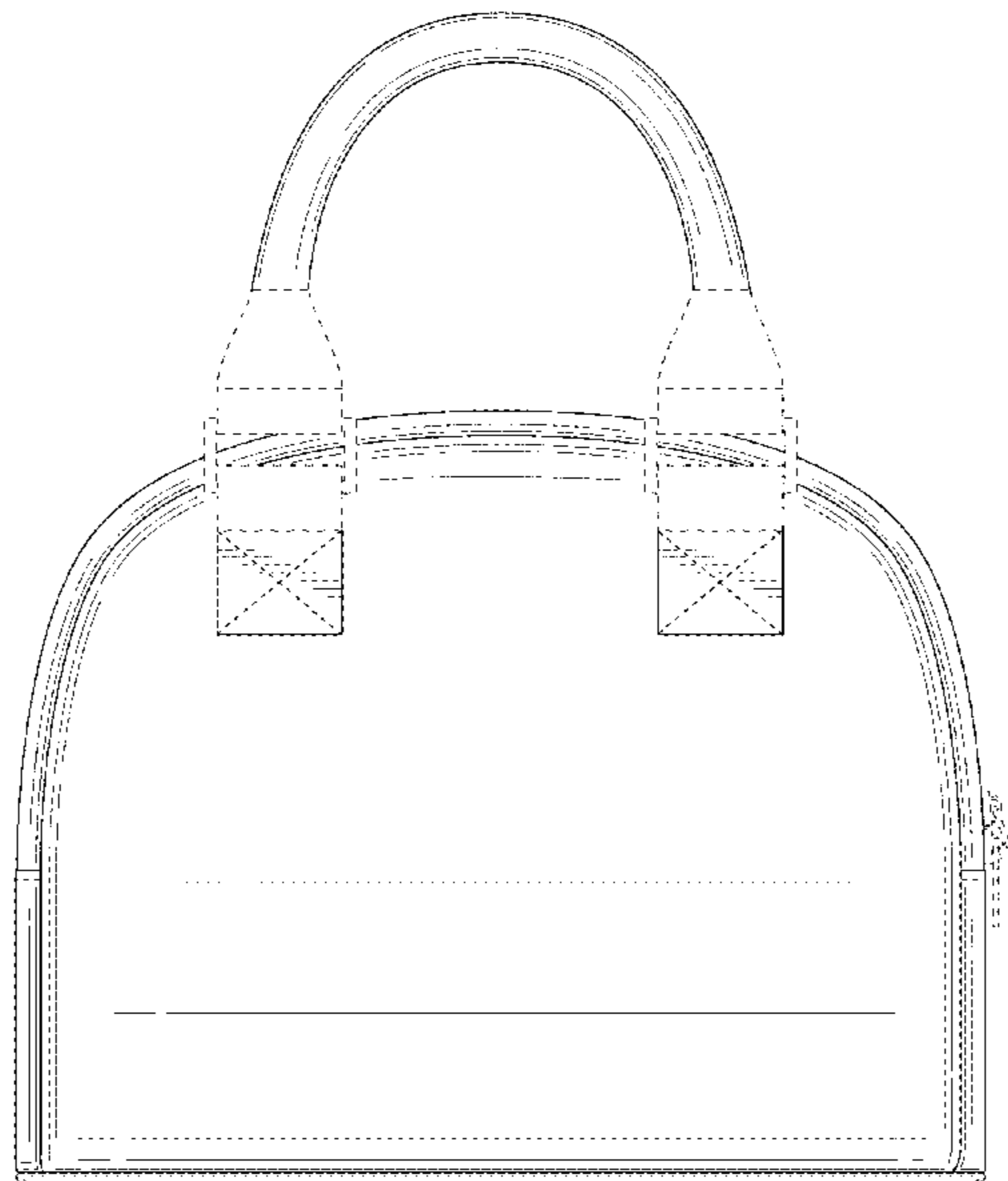

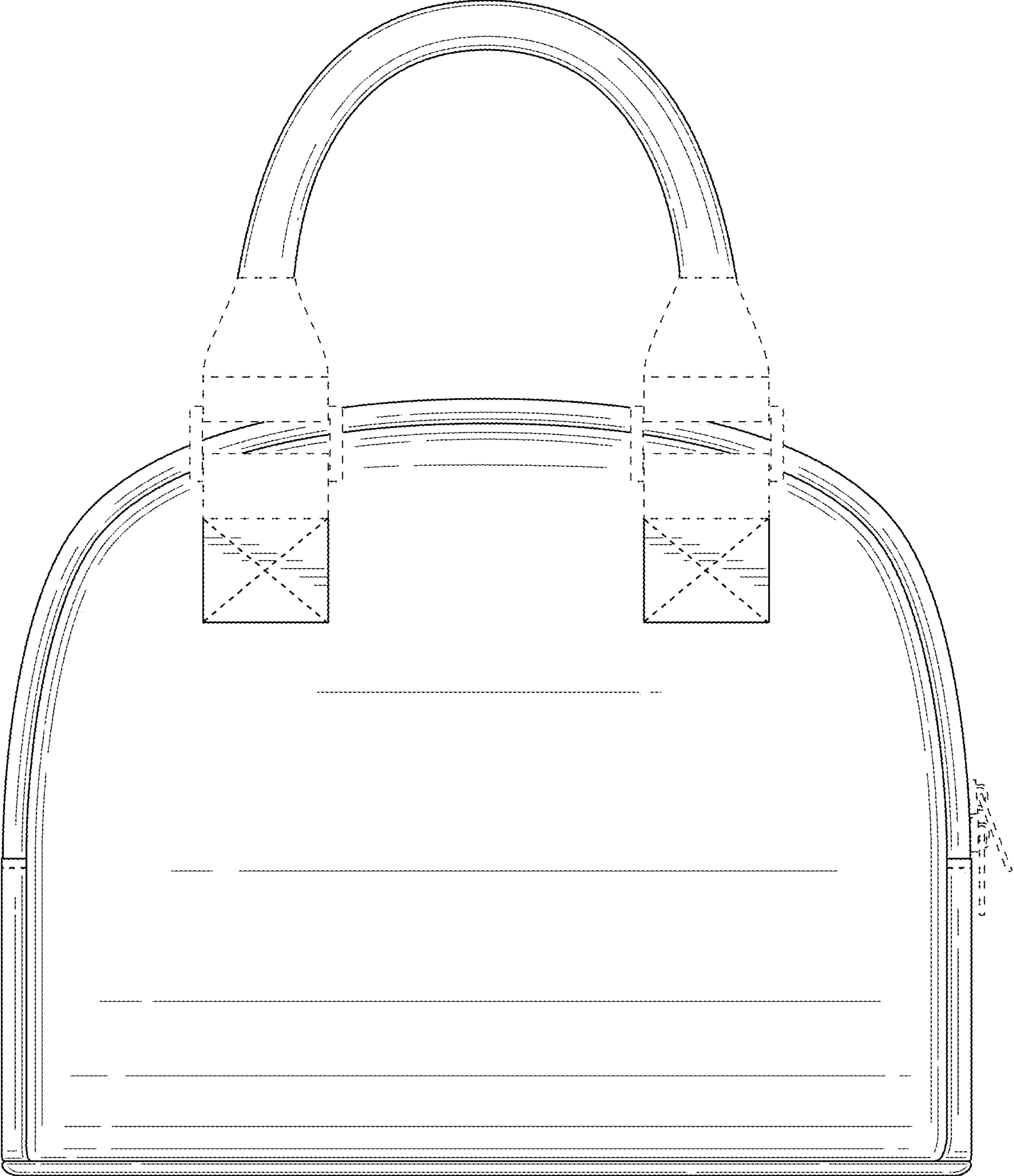

FIG. 1

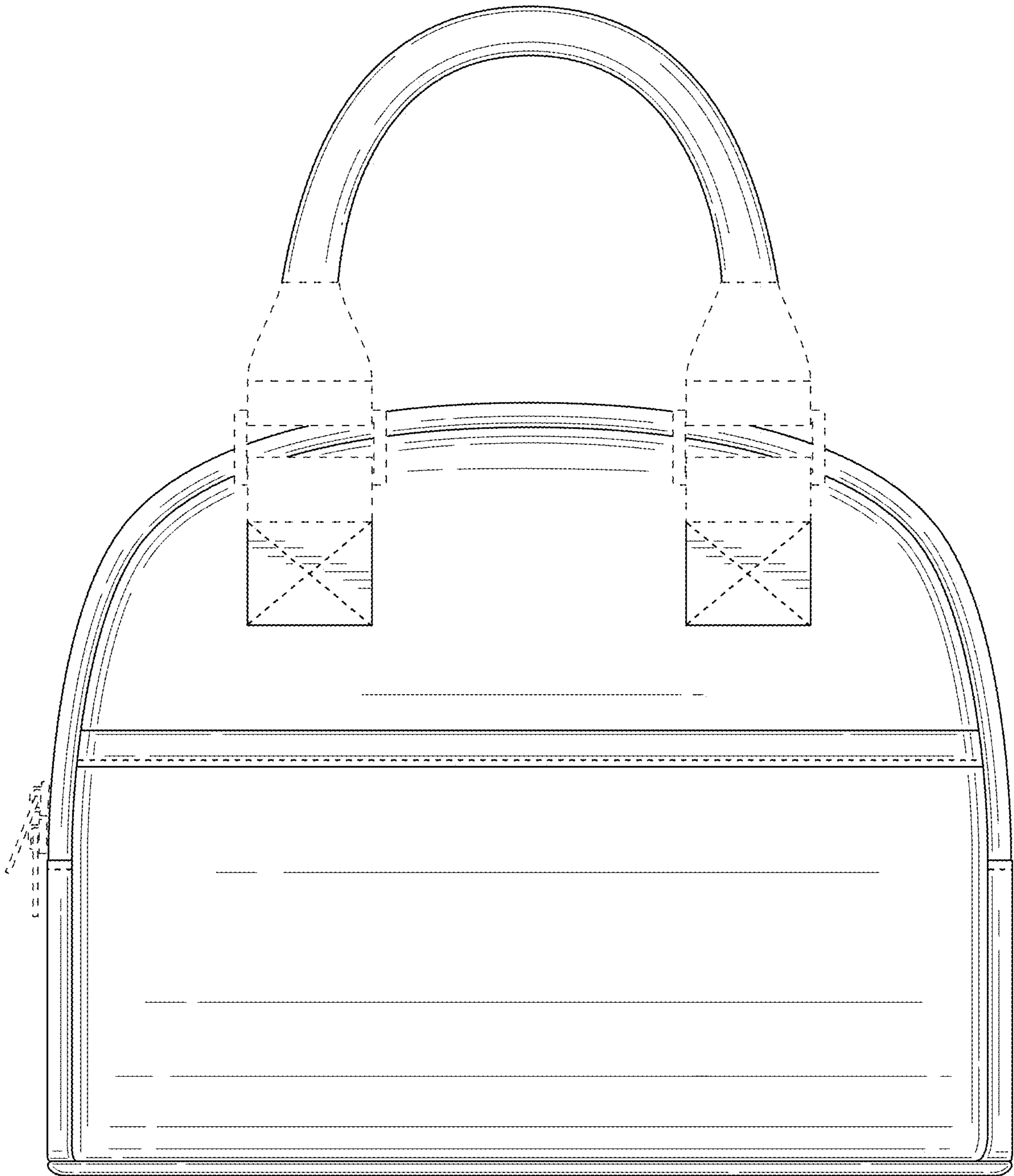

FIG. 2

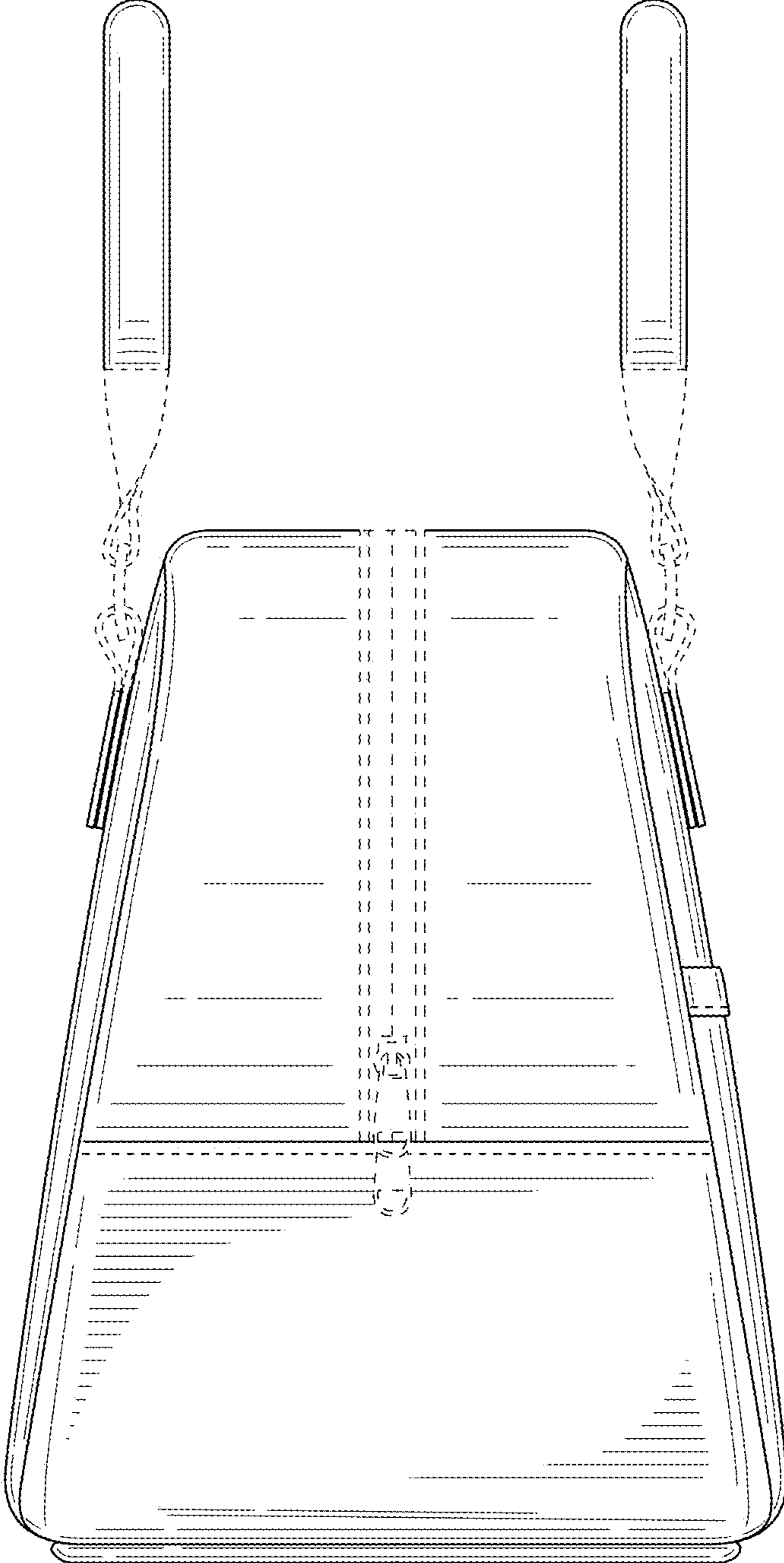

FIG. 3

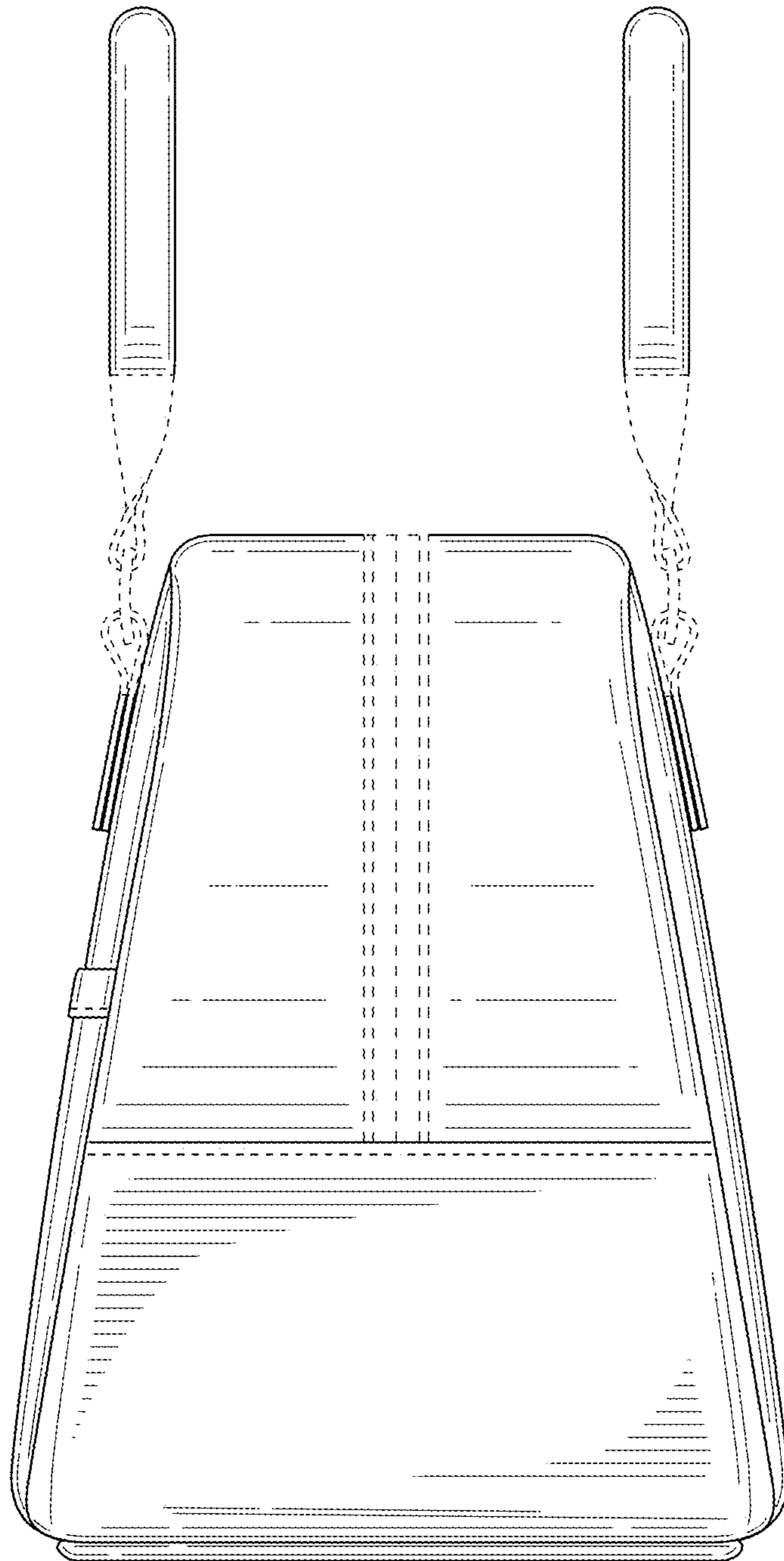

FIG. 4



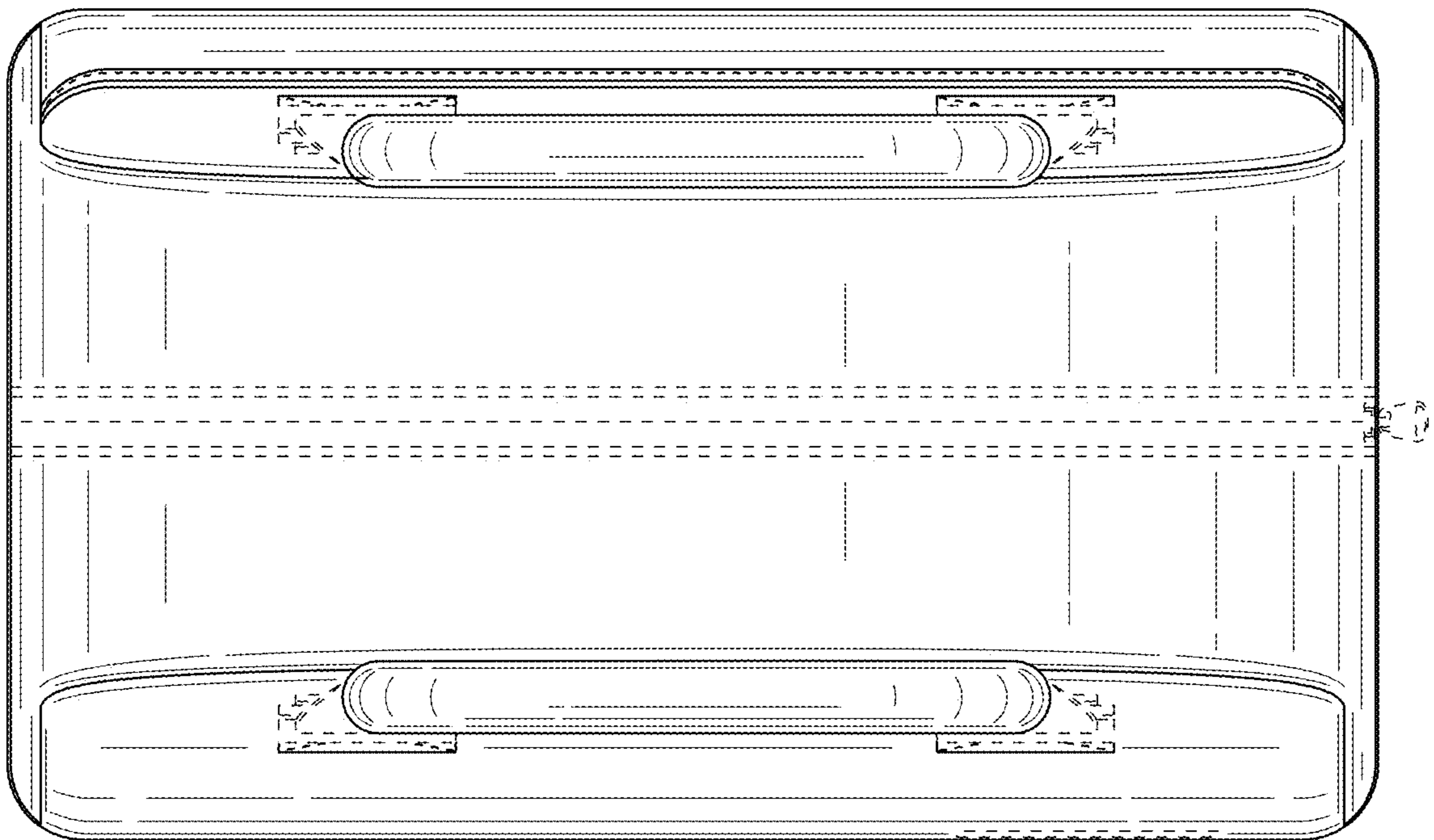

FIG. 5



FIG. 6