



US00D973768S

(12) **United States Design Patent** (10) **Patent No.:** **US D973,768 S**
Goerig et al. (45) **Date of Patent:** **** Dec. 27, 2022**

(54) **EDUCATIONAL NUMBER LINE**

(71) Applicant: **hand2mind, Inc.**, Vernon Hills, IL (US)

(72) Inventors: **Brittany Goerig**, Midlothian, TX (US);
Jared Ganrude, Arlington Heights, IL (US);
Elana Woldenberg, Chicago, IL (US);
Andy Chan, Kwuntong (CN)

(73) Assignee: **hand2mind, Inc.**, Vernon Hills, IL (US)

(**) Term: **15 Years**

(21) Appl. No.: **29/709,004**

(22) Filed: **Oct. 10, 2019**

(51) **LOC (13) Cl.** **19-07**

(52) **U.S. Cl.**
USPC **D19/59**

(58) **Field of Classification Search**
USPC D14/367, 433; D21/341, 342, 366;
D19/59-64

(Continued)

(56) **References Cited**

U.S. PATENT DOCUMENTS

682,912 A * 9/1901 Castner A63F 1/18
D19/64
1,816,760 A * 7/1931 Barnowitz G09B 3/02
D19/64

(Continued)

FOREIGN PATENT DOCUMENTS

CN 202205032 U 4/2012
CN 304354670 * 11/2017
CN 304927752 * 12/2018

OTHER PUBLICATIONS

Didax Educational Resources Number Line, Amazon.com, date published May 26, 2016, date retrieved from internet Apr. 22, 2022-
<https://amzn.to/36YsuXA> (Year: 2016).*

(Continued)

Primary Examiner — Jennifer L Rempfer
Assistant Examiner — Danielle Nichole Bowly
(74) *Attorney, Agent, or Firm* — Michael Best & Friedrich LLP

(57) **CLAIM**

The ornamental design for an educational number line, as shown and described.

DESCRIPTION

FIG. 1 is a front perspective view of an educational number line showing our new design in a first configuration; FIG. 2 is a front view of the educational number line of FIG. 1 in the first configuration; FIG. 3 is a rear view of the educational number line of FIG. 1 in the first configuration; FIG. 4 is a left side view of the educational number line of FIG. 1 in the first configuration; FIG. 5 is a right side view of the educational number line of FIG. 1 in the first configuration; FIG. 6 is a top view of the educational number line of FIG. 1 in the first configuration; FIG. 7 is a bottom view of the educational number line of FIG. 1 in the first configuration; FIG. 8 is a front perspective view of the educational number line of FIG. 1 in a second configuration; FIG. 9 is a front view of the educational number line of FIG. 1 in the second configuration; FIG. 10 is a top view of the educational number line of FIG. 1 in the second configuration; FIG. 11 is a bottom view of the educational number line of FIG. 1 in the second configuration; FIG. 12 is a rear view of the educational number line of FIG. 1 in the second configuration; FIG. 13 is a left side view of the educational number line of FIG. 1 in the second configuration; and, FIG. 14 is a right side view of the educational number line of FIG. 1 in the second configuration. The broken lines illustrate unclaimed portions of the educational number line and form no part of the claimed design.

1 Claim, 9 Drawing Sheets

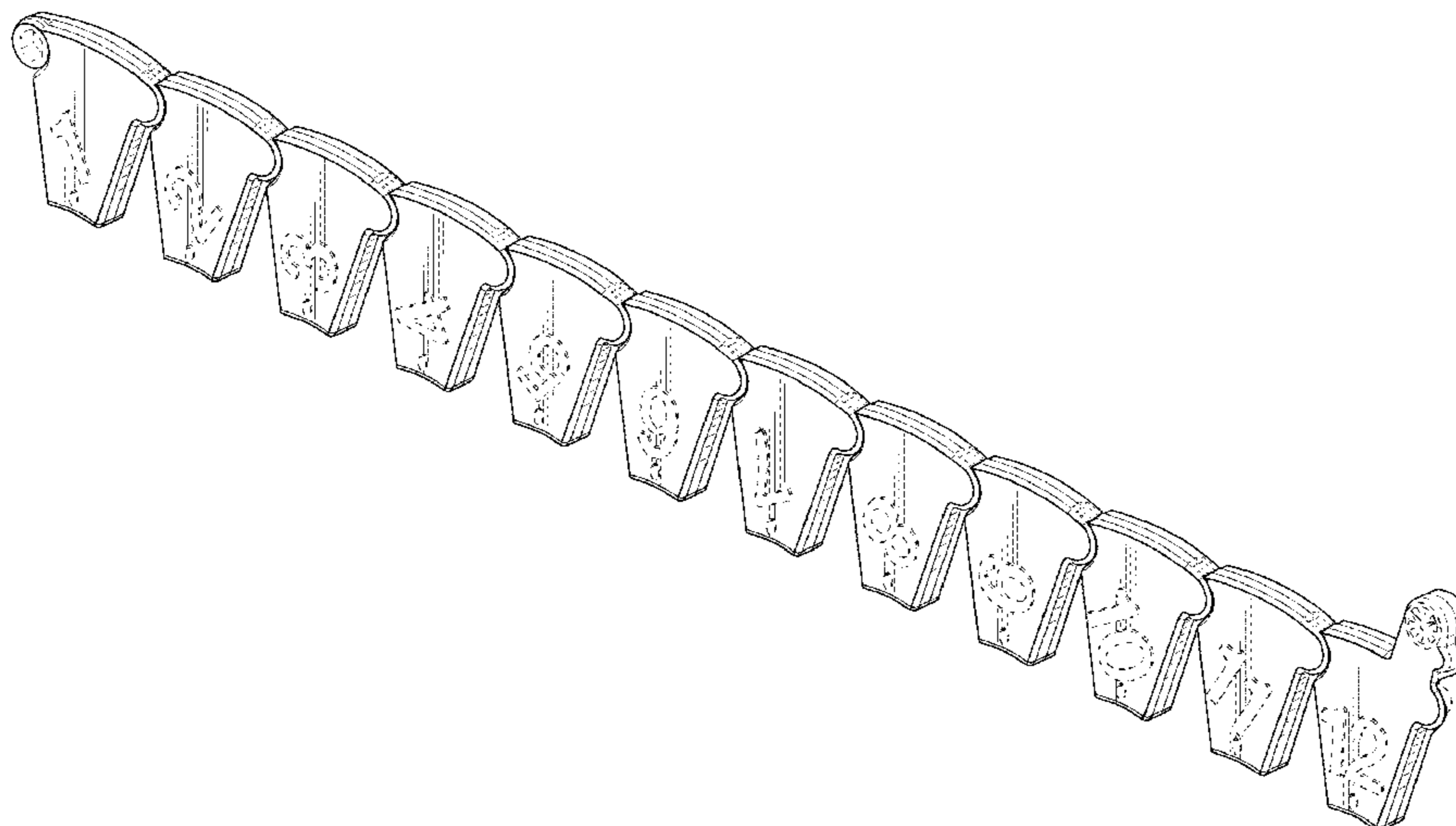

(58) **Field of Classification Search**
 CPC G09B 1/14; G09B 19/02
 See application file for complete search history.

(56) **References Cited**

U.S. PATENT DOCUMENTS

2,430,599 A * 11/1947 Batori G06G 1/04
 235/84
 2,610,853 A * 9/1952 Livingston A63F 5/02
 273/121 R
 D168,834 S * 2/1953 Farinacci D18/9
 3,001,301 A * 9/1961 Carl G09B 19/02
 D19/64
 D205,401 S * 8/1966 Schmoyer D19/59
 3,526,045 A * 9/1970 Stone G09B 19/02
 434/209
 3,597,918 A 8/1971 Robinson
 3,645,087 A 2/1972 Rams
 3,852,949 A 12/1974 Saylor
 3,956,879 A 5/1976 Bailey
 D242,877 S * 12/1976 Bologna D17/9
 4,103,484 A 8/1978 Bailey
 D269,977 S * 8/1983 Gopfert D19/64
 4,682,955 A * 7/1987 Wada G09B 1/14
 434/191
 4,808,111 A * 2/1989 Pratt G09B 19/02
 434/191
 D308,698 S * 6/1990 Dorman D19/59
 5,030,104 A 7/1991 Caldwell
 5,299,178 A 3/1994 Belik
 D350,772 S * 9/1994 King D19/64
 D386,927 S * 12/1997 Meade D6/601
 5,851,118 A 12/1998 Woldenberg et al.
 D404,435 S * 1/1999 Gagnon D21/366
 D419,617 S * 1/2000 Wise D21/531
 6,354,841 B1 * 3/2002 Bradt G09B 19/12
 368/45
 D462,391 S * 9/2002 Allen D10/128
 D529,961 S * 10/2006 Gallagher D19/62
 7,534,106 B1 * 5/2009 Dutcher G09B 19/02
 434/188
 8,355,297 B2 1/2013 Wilbur et al.
 8,611,192 B2 12/2013 Balter et al.

D937,357 S * 11/2021 Ju D21/457
 11,173,336 B1 * 11/2021 Xu A63B 21/0608
 D954,857 S * 6/2022 Yang D21/662
 2006/0014127 A1 1/2006 Lin
 2009/0081625 A1 * 3/2009 Baerg G09B 1/14
 434/209
 2020/0117145 A1 4/2020 Monferrer

OTHER PUBLICATIONS

International Search Report and Written Opinion for Application No. PCT/CN2019/110261 dated Jul. 10, 2020 (8 pages).
 Learning Resources®, “Magnetic Elapsed Time Set,” <<https://www.learningresources.com/magnetic-elapsed-time-set>>, web page publicly available as early as May 22, 2020, representative copy filed with IDS was captured Jun. 2021 (3 pages).
 Cpalms, “Number Line Clock Directives” [retrieved on May 29, 2020 from http://www.cpalms.org/uploads/resources/44544/Number_Line_Clock_Directions.pdf, available prior to Oct. 10, 2019] (3 pages).
 Georgia Department of Education, Georgia Standards of Excellence Framework, GSE Understanding Measurement, Length, and Time, Unit 3 [retrieved from <https://www.georgiastandards.org/Georgia-Standards/Frameworks/2nd-Math-Unit-3.pdf>, available prior to Oct. 10, 2019] (99 pages).
 Learning Resources, “Big Time™ Student Clock” [retrieved on May 29, 2020 from <https://web.archive.org/web/20170705182501/https://www.learningresources.com/product/big+time-8482--student-clock.do?sortby=ourPicks&refType=&from=fn>, available on Jul. 5, 2017 per Internet Archive Wayback Machine] (1 page).
 Hand2mind, Magnetic Elapsed Time Set: [retrieved on Jun. 26, 2020 from <https://web.archive.org/web/20170618232134/http://www.hand2mind.com/item/magnetic-elapsed-time-set/2478>, available on Jun. 18, 2017 per Internet Archive Wayback Machine] (2 pages).
 SMathSmarts, “Relating a Clock to a Number Line” [retrieved on May 29, 2020 from <https://web.archive.org/web/20190320213155/http://smathsmarts.com/relating-a-clock-to-a-number-line/>, available on Mar. 20, 2019 per Internet Archive Wayback Machine] (3 pages).
 YouTube, “Circle a number line into a clock”, <<https://www.youtube.com/watch?v=Yw31gABRkoc>>, published Feb. 11, 2014 (1 page).

* cited by examiner

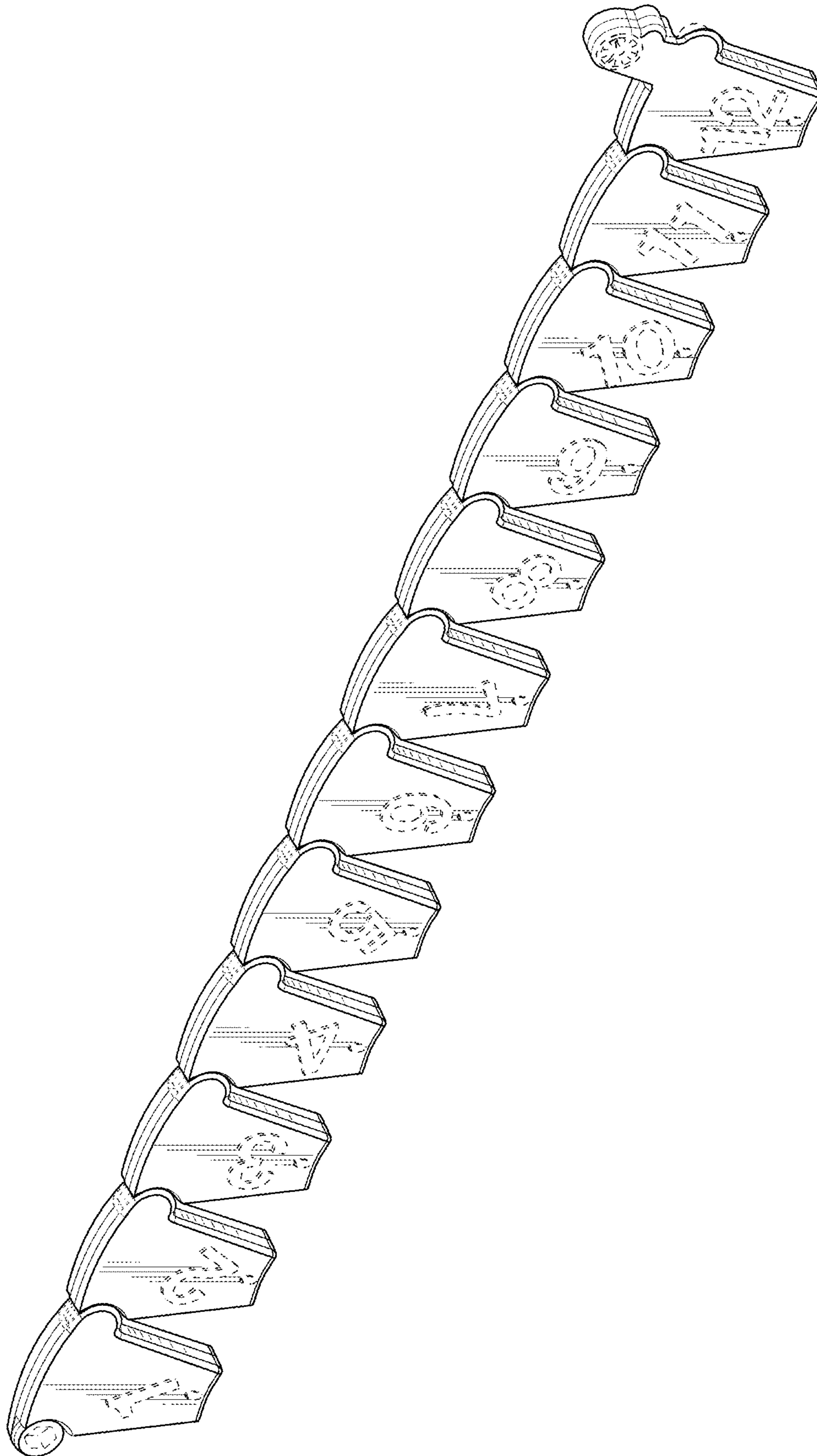

FIG. 1

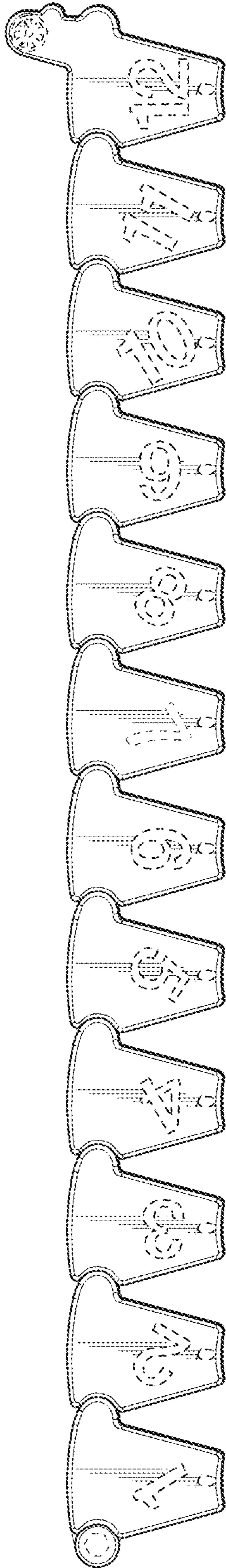

FIG. 2

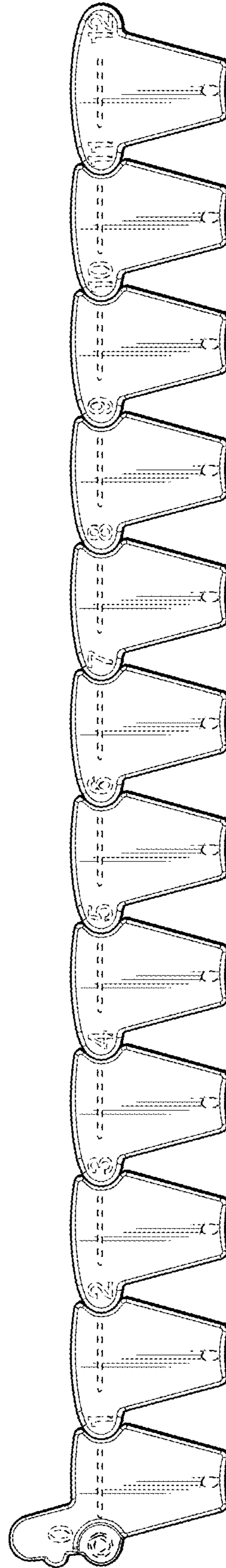

FIG. 3



FIG. 4



FIG. 5

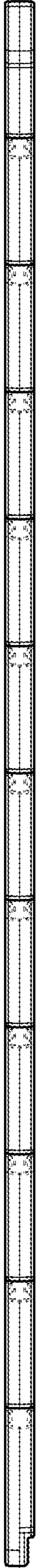

FIG. 6



FIG. 7

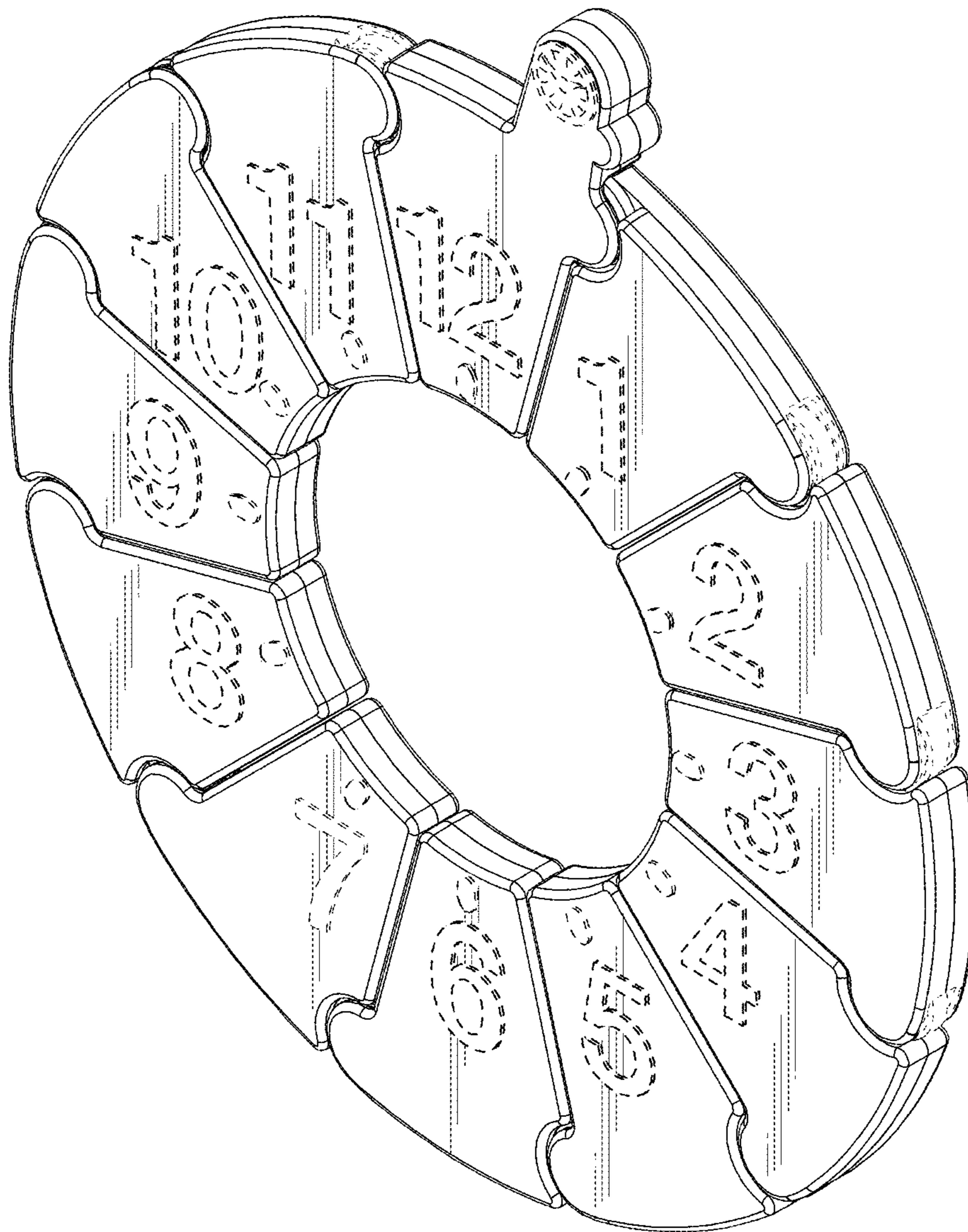

FIG. 8

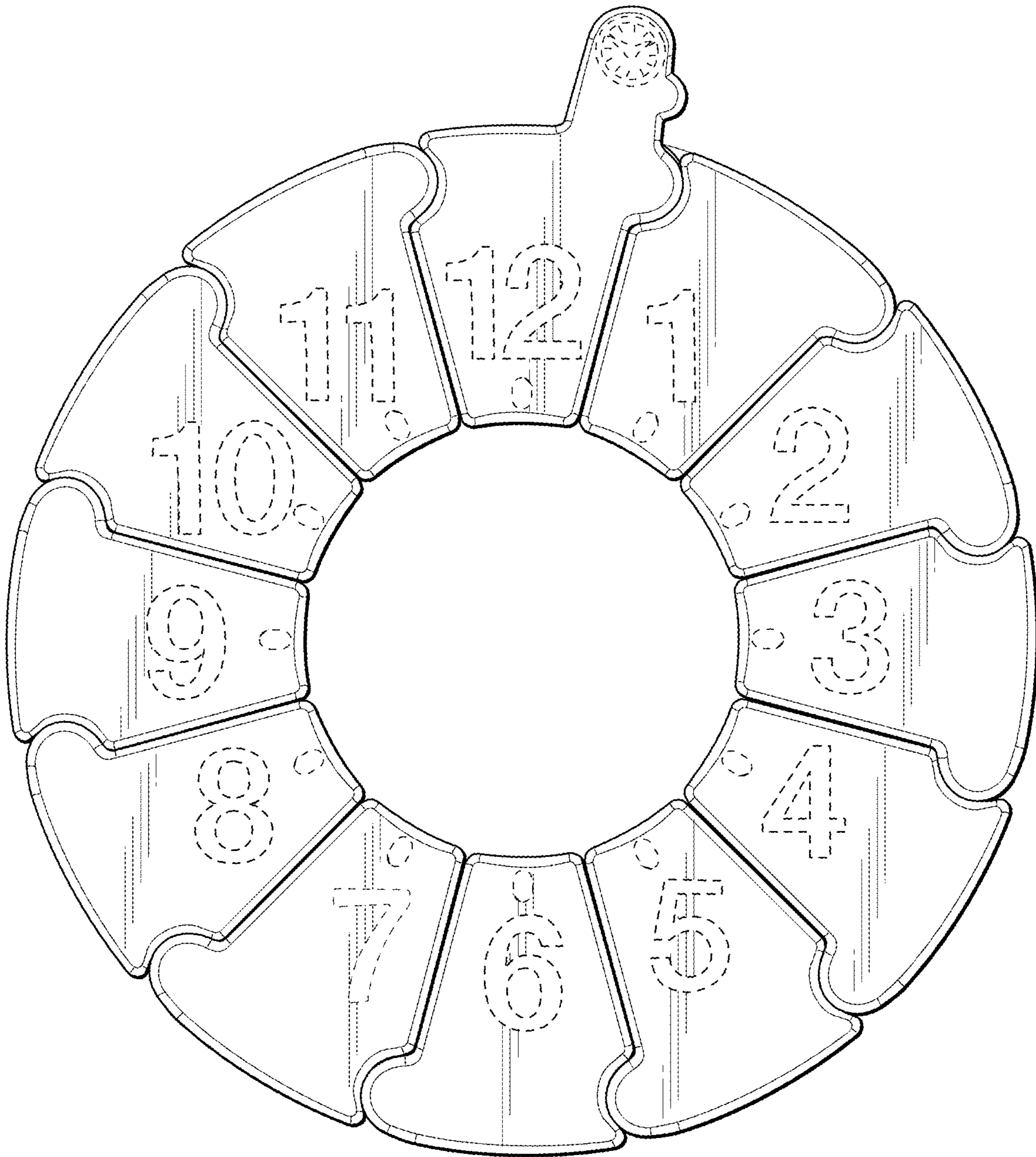

FIG. 9



FIG. 10

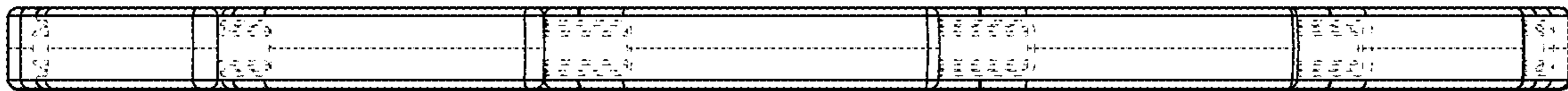

FIG. 11

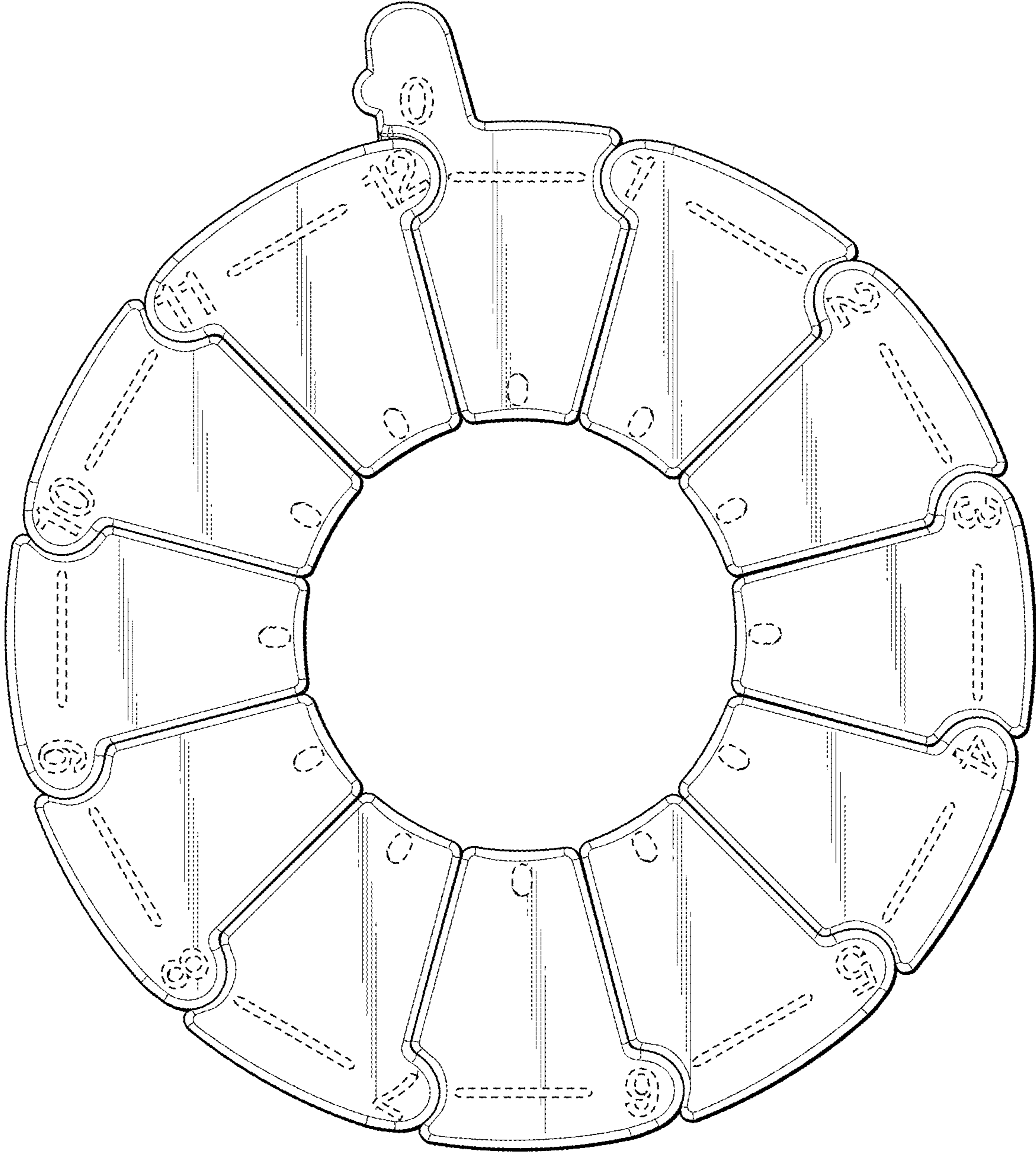

FIG. 12

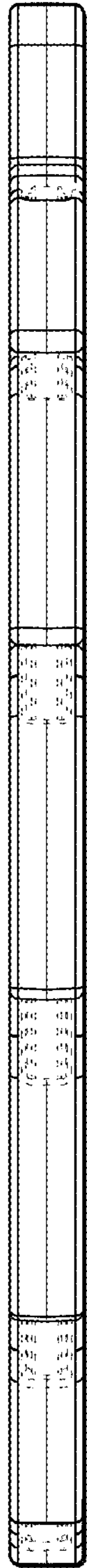

FIG. 13

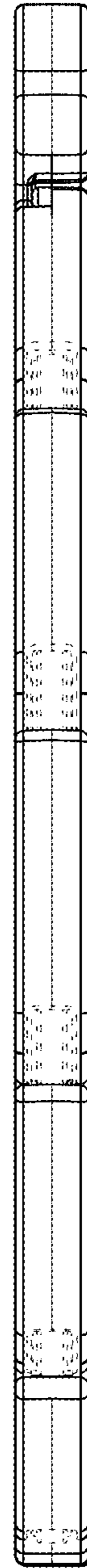

FIG. 14