



US00D973763S

(12) **United States Design Patent** (10) **Patent No.:** **US D973,763 S**
Slaton (45) **Date of Patent:** **** Dec. 27, 2022**

(54) **PEDALBOARD**

(71) Applicant: **Guitar Center, Inc.**, Westlake Village, CA (US)

(72) Inventor: **Robin Richard Slaton**, Fort Collins, CO (US)

(73) Assignee: **Guitar Center, Inc.**, Westlake Village, CA (US)

(**) Term: **15 Years**

(21) Appl. No.: **29/796,319**

(22) Filed: **Jun. 23, 2021**

(51) **LOC (13) Cl.** **17-03**

(52) **U.S. Cl.**
USPC **D17/20**

(58) **Field of Classification Search**
USPC D17/9, 13, 20, 24, 99; D21/405;
D14/158, 172, 203.1, 210, 215, 216, 217
CPC G10D 99/00; G10D 13/11; G10H 1/0033;
G10H 1/0066; G10H 1/0575; G10F 1/06
See application file for complete search history.

(56) **References Cited**

U.S. PATENT DOCUMENTS

6,459,023	B1	10/2002	Chandler	
6,538,185	B1	3/2003	Stratton	
8,138,406	B2	3/2012	Vinciguerra	
D776,188	S *	1/2017	Beck D17/1

D809,484	S *	2/2018	Shi	D14/217
D819,121	S *	5/2018	Kushner	D17/20
D832,333	S *	10/2018	Kushner	D17/20
D832,334	S *	10/2018	Kushner	D17/20
D862,577	S *	10/2019	Lackner	D17/20
D862,579	S *	10/2019	Lackner	D17/20
D862,582	S *	10/2019	Lackner	D17/20
D934,337	S *	10/2021	Trifilio	D17/20
D934,948	S *	11/2021	Trifilio	D17/20
D959,541	S *	8/2022	Trifilio	D17/20
D959,542	S *	8/2022	Trifilio	D17/20
2004/0250673	A1	12/2004	Salerno		
2019/0287504	A1	9/2019	O'Brien		

* cited by examiner

Primary Examiner — R. Johnson

(74) *Attorney, Agent, or Firm* — SoCal IP Law Group LLP; Guy Cumberbatch; Steven Sereboff

(57) **CLAIM**

The ornamental design for a pedalboard, as shown and described.

DESCRIPTION

FIG. 1 is a top perspective view of a pedalboard; FIG. 2 is a bottom perspective view of the pedalboard; FIG. 3 is a left side elevational view of the pedalboard; the right side elevational view is a mirror image of the left side; FIG. 4 is a front elevational view of the pedalboard; FIG. 5 is a rear elevational view of the pedalboard; FIG. 6 is a top plan view of the pedalboard; and, FIG. 7 is a bottom plan view of the pedalboard.

1 Claim, 5 Drawing Sheets

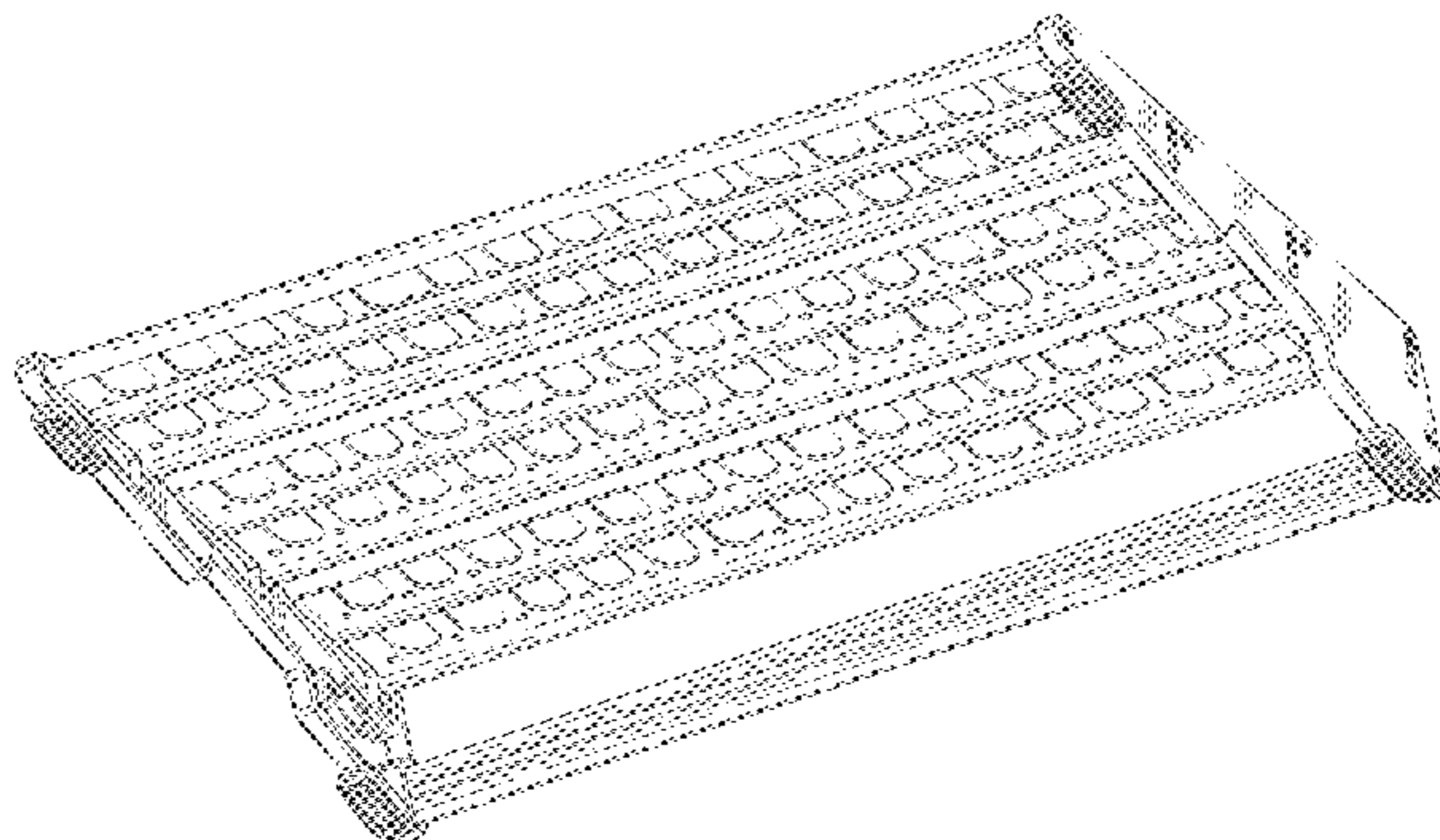
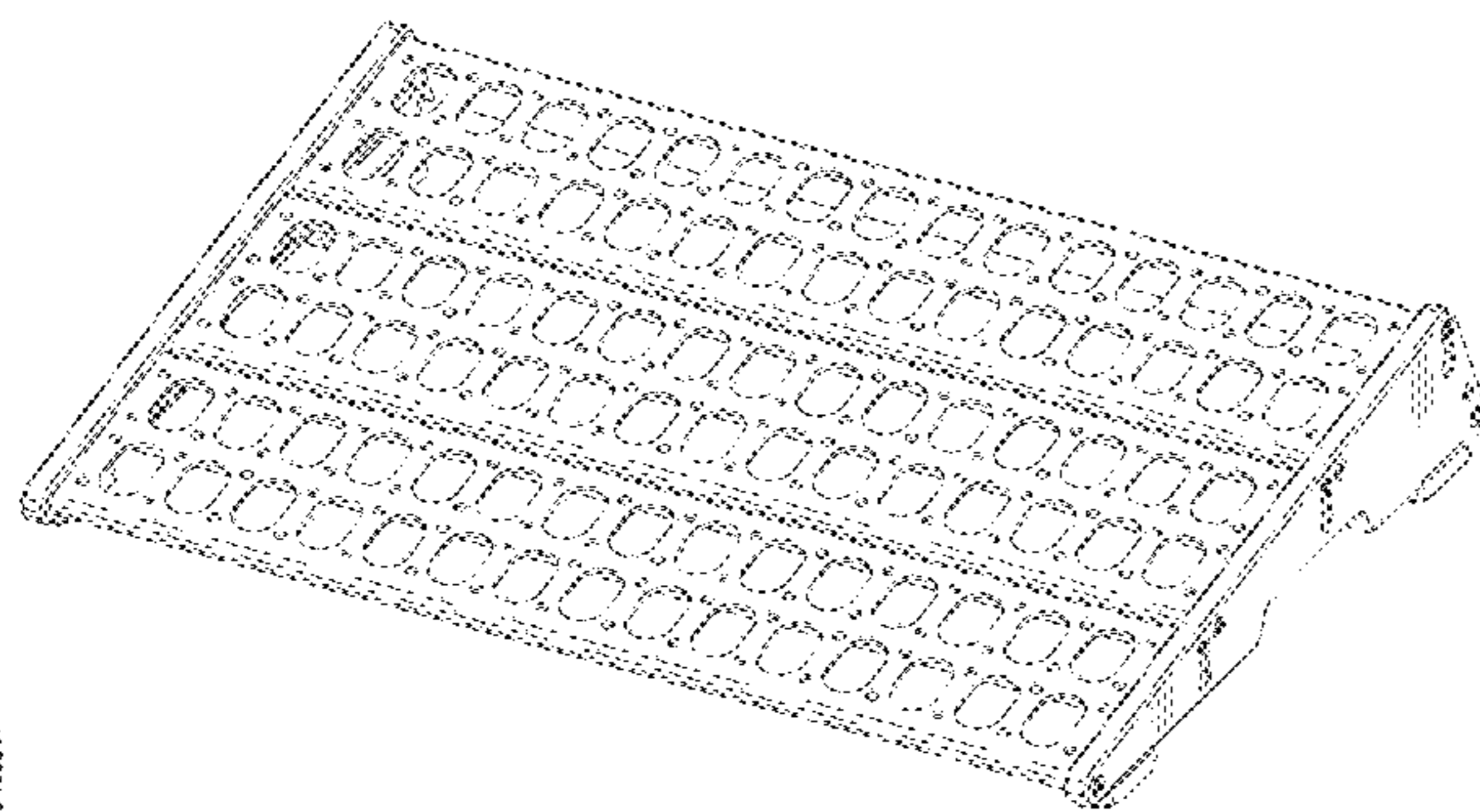

© 2021 Guitar Center, Inc.

© 2021 Guitar Center, Inc.

Fig. 1

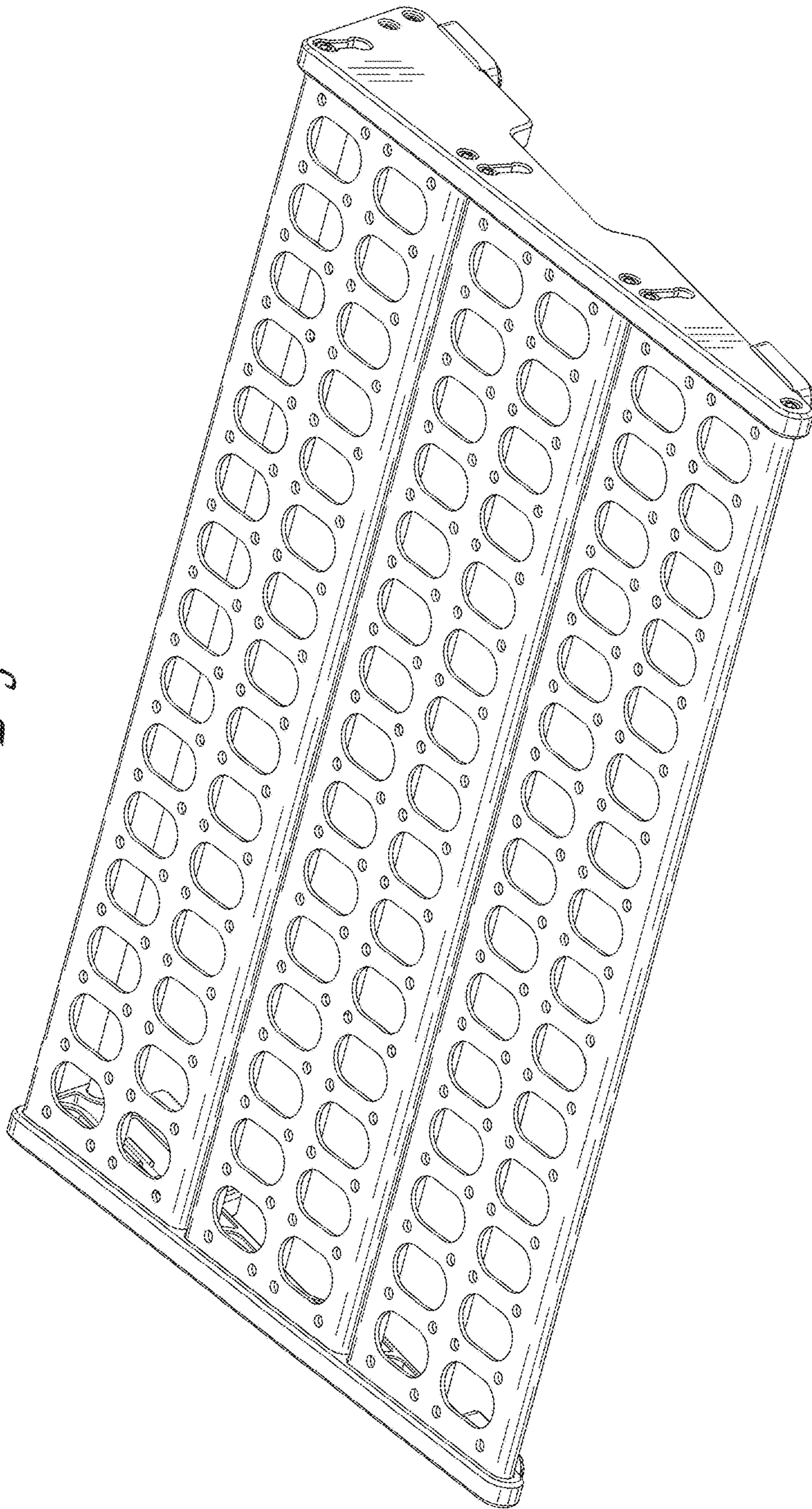

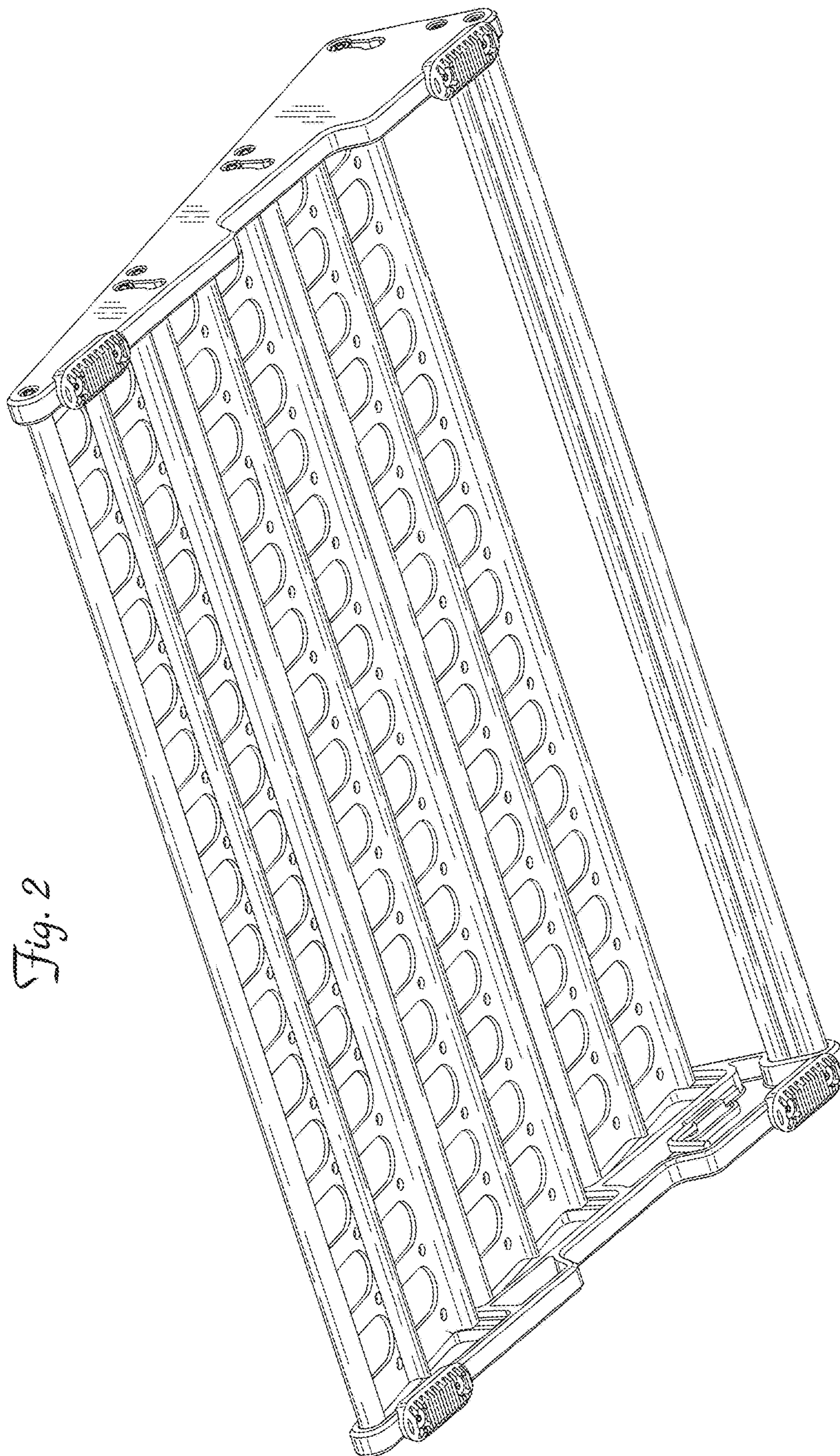

Fig. 2

Fig. 3

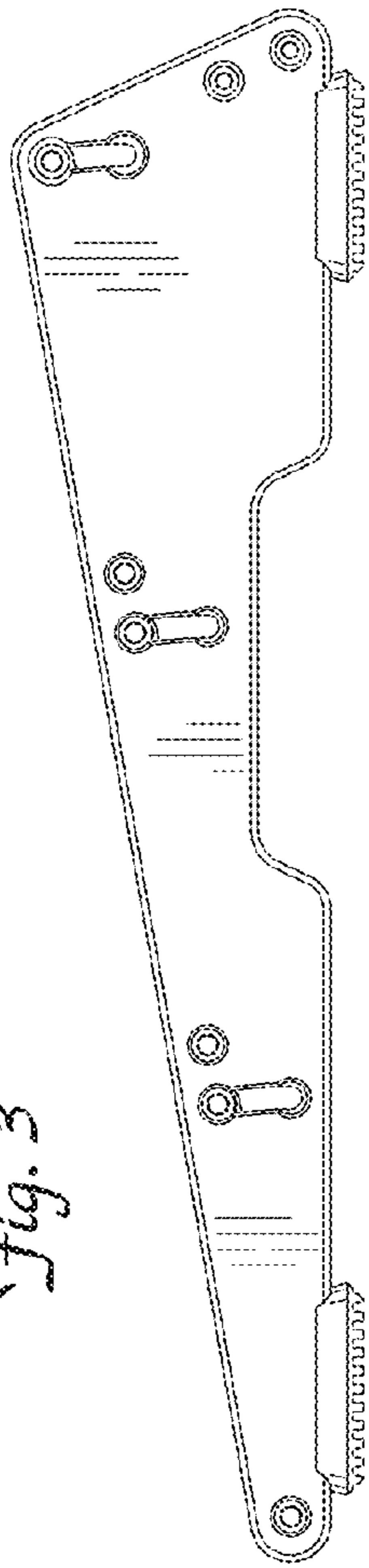

Fig. 4

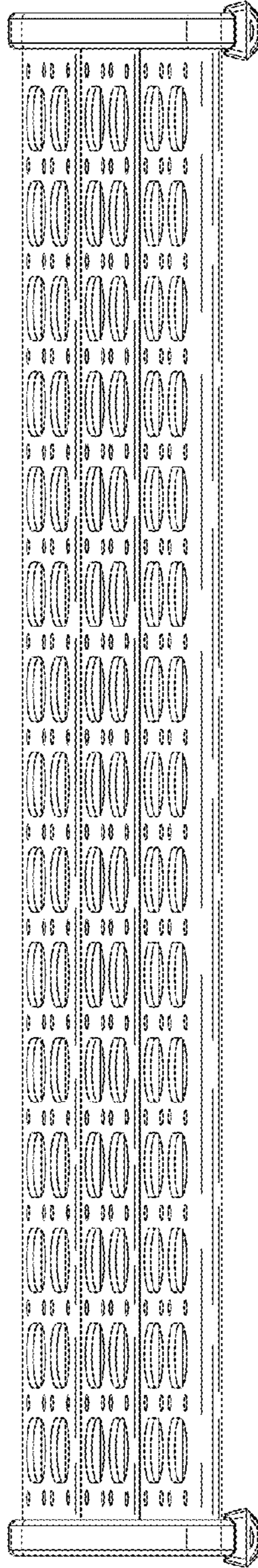

Fig. 5

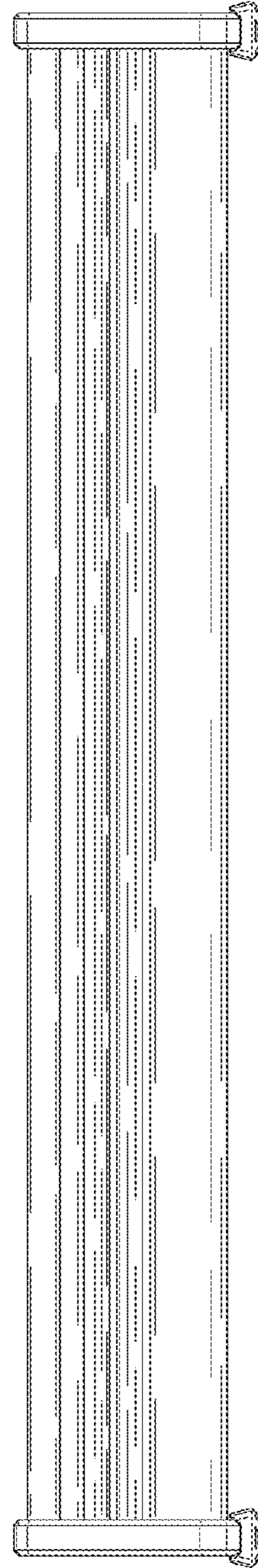

Fig. 6

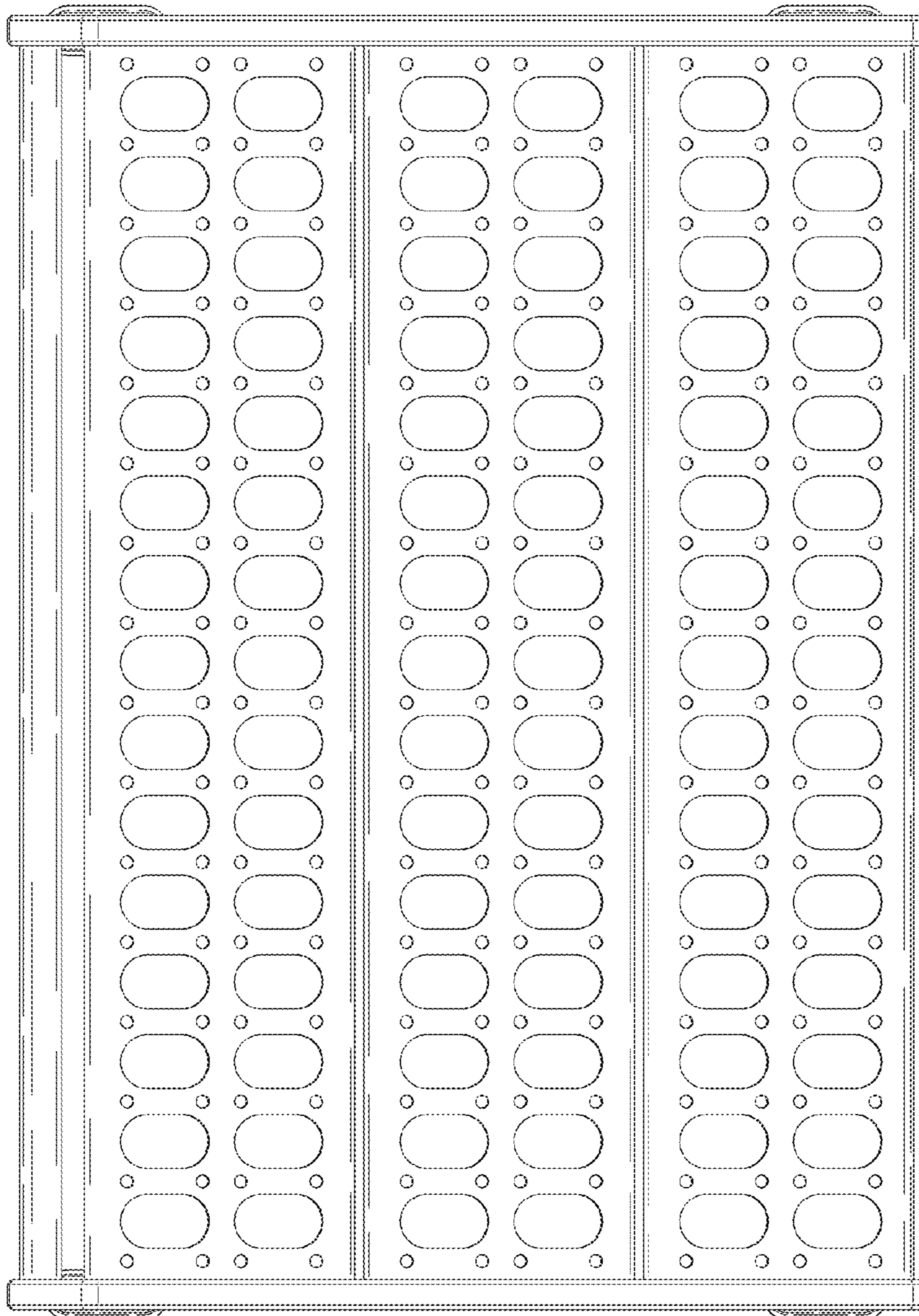

Fig. 7

