



US00D973579S

(12) **United States Design Patent**
Azuma

(10) **Patent No.:** **US D973,579 S**
(45) **Date of Patent:** **** Dec. 27, 2022**

(54) **BATTERY MODULE FOR ELECTRIC POWER UNIT**

(71) Applicant: **HONDA MOTOR CO., LTD.**, Tokyo (JP)

(72) Inventor: **Koichi Azuma**, Wako (JP)

(73) Assignee: **HONDA MOTOR CO., LTD.**, Tokyo (JP)

(**) Term: **15 Years**

(21) Appl. No.: **29/701,883**

(22) Filed: **Aug. 15, 2019**

(30) **Foreign Application Priority Data**

Feb. 19, 2019 (JP) 2019-003233

(51) **LOC (13) Cl.** **13-02**

(52) **U.S. Cl.**
USPC **D13/103**

(58) **Field of Classification Search**

USPC D13/102-110, 118, 119, 153, 154, 184, D13/199, 103

CPC Y02E 60/10; Y02E 60/12; Y02E 60/122; Y02E 60/124; Y02E 60/50; H01M 2/02; H01M 2/022; H01M 2/0202; H01M 2/0207; H01M 2/0212; H01M 2/1061; H01M 2/1022; H01M 2/1055; H01M 2/1066; H01M 2/105; H01M 2/20; H01M 2/202; H01M 2/204; H01M 2/206; H01M 2200/30; H01M 2250/30; H01M 2250/40; H01M 10/44; H01M 10/46; H01M 10/465; H01M 10/482; H01M 10/4257; H01M 10/0436; H01M 10/48; H01M 10/6235; H02J 7/0034; H02J 7/0054; H02J 7/1423; H02J 7/00; H02J 7/0003; H02J 7/0011; H02J 7/0013; H02J 7/0055; H02J 7/0057; Y02T 10/7005; Y02T 10/705; Y02T 10/7088

See application file for complete search history.

(56) **References Cited**

U.S. PATENT DOCUMENTS

D400,161 S * 10/1998 Nagele D13/103
D504,110 S * 4/2005 Berentzen D13/103

(Continued)

OTHER PUBLICATIONS

Global.honda./ Honda to Unveil World Premiere of the eGX Prototype . . . Publish date of Mar. 29, 2019. Retrieved from the internet at <<https://global.honda/newsroom/news/2019/p190329eng.html>>, Feb. 24, 2022. 1 page. (Year: 2019).*

Primary Examiner — Christy Nemeth

(74) *Attorney, Agent, or Firm* — WHDA, LLP

(57) **CLAIM**

The ornamental design for a battery module for electric power unit, as shown and described.

DESCRIPTION

FIG. 1 is a front and right perspective view of a battery module for electric power unit;
FIG. 2 is a front and left perspective view thereof;
FIG. 3 is a rear and right perspective view thereof;
FIG. 4 is a rear and left perspective view thereof;
FIG. 5 is a front elevation view thereof;
FIG. 6 is a rear elevation view thereof;
FIG. 7 is a right side elevation view thereof;
FIG. 8 is a left side elevation view thereof;
FIG. 9 is a top plan view thereof;
FIG. 10 is a bottom plan view thereof; and,
FIG. 11 is a perspective view of the battery module for electric power unit, shown in an environment of use.
The broken lines in the drawings are for the purpose of illustrating portions of the battery module for electric power unit and environment that form no part of the claimed design.

1 Claim, 11 Drawing Sheets

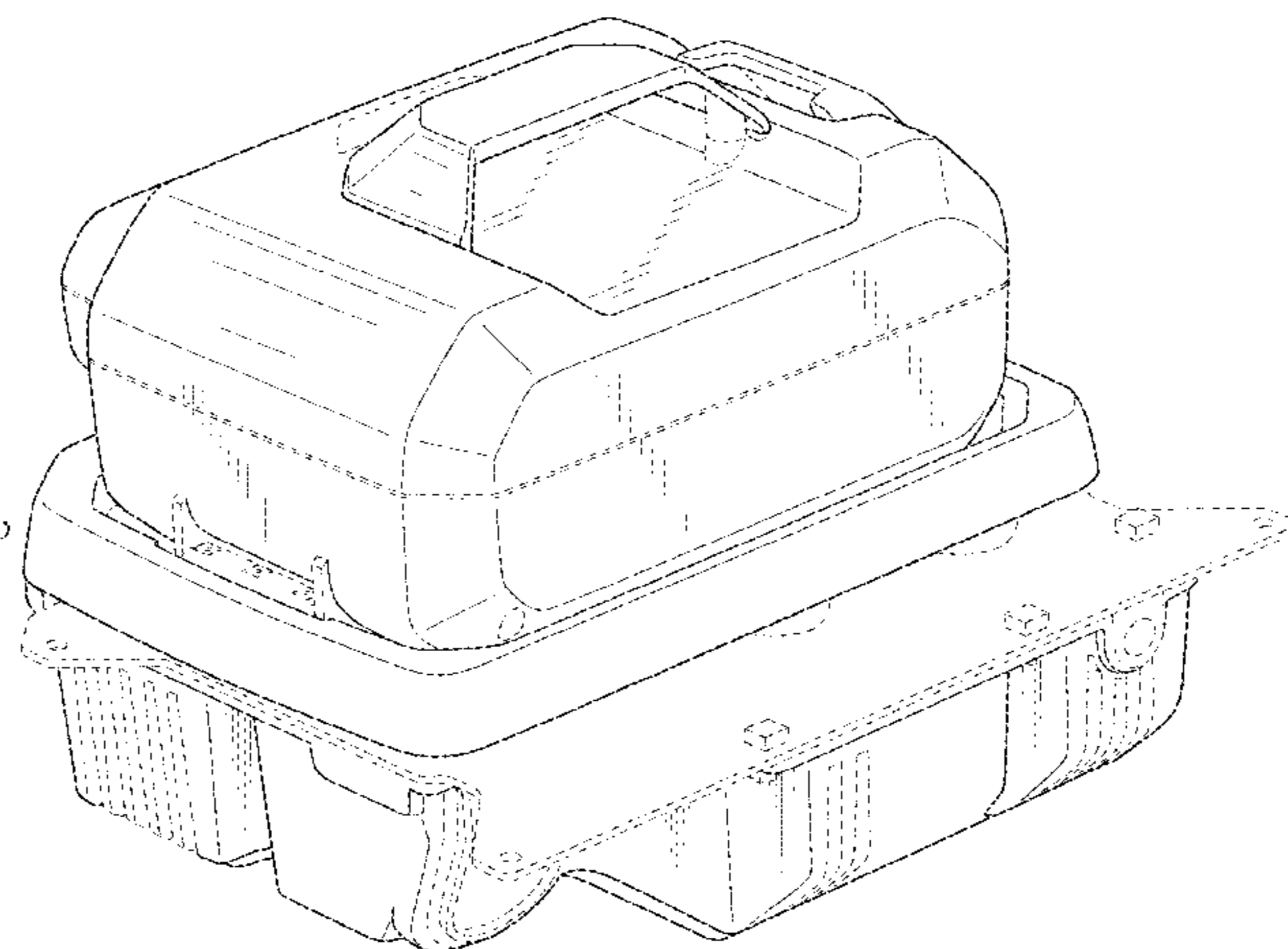
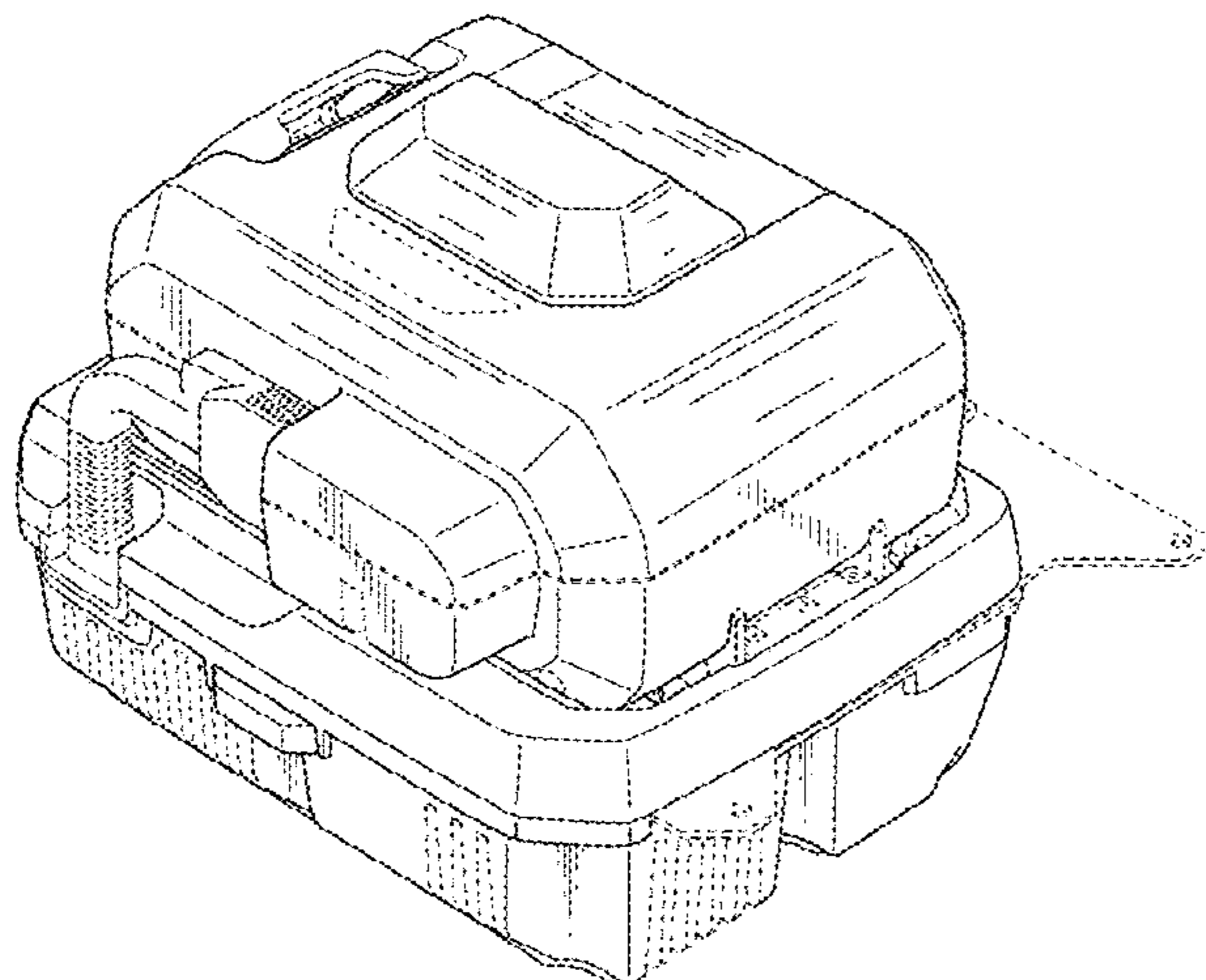

(56)

References Cited

U.S. PATENT DOCUMENTS

D803,777 S	*	11/2017	Burchard	D13/103
D826,149 S	*	8/2018	Cooper	D13/103
D834,517 S	*	11/2018	Fritz	D13/116
D905,639 S	*	12/2020	Azuma	D13/116
D917,395 S	*	4/2021	Azuma	D13/116
D929,316 S	*	8/2021	Azuma	D13/103
D937,210 S	*	11/2021	Azuma	D13/116
D942,375 S	*	2/2022	Azuma	D13/103

* cited by examiner

FIG. 1

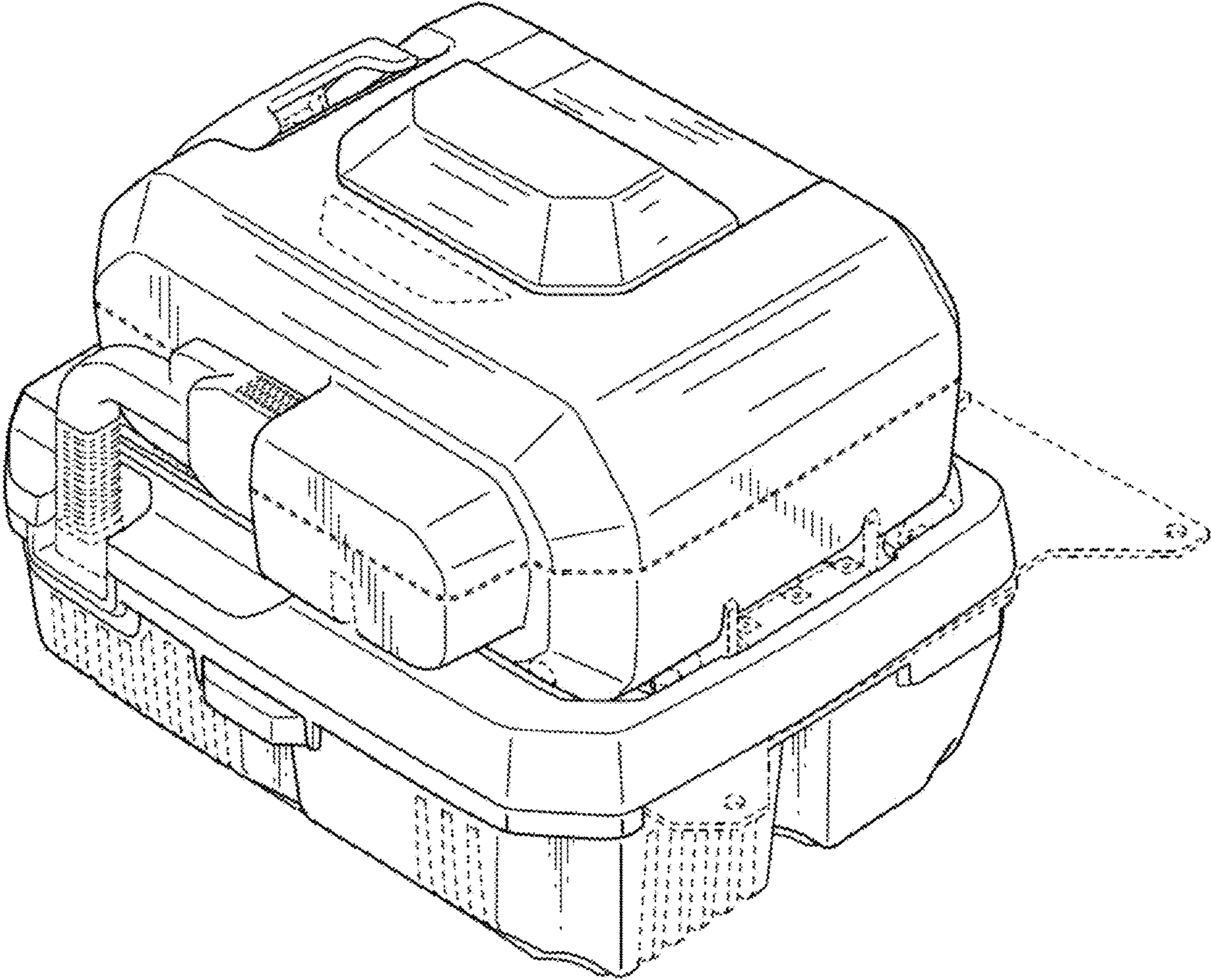

FIG. 2

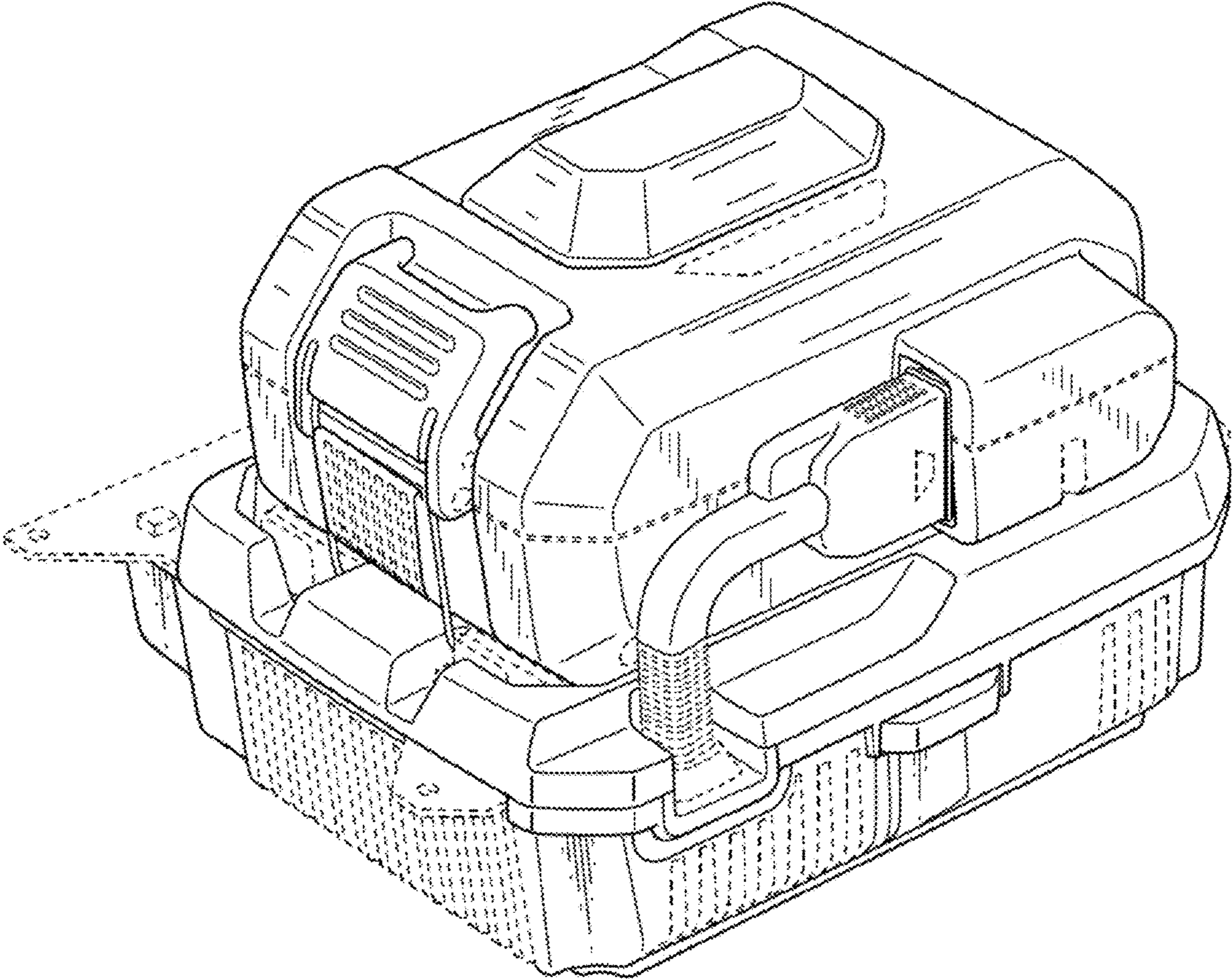

FIG. 3

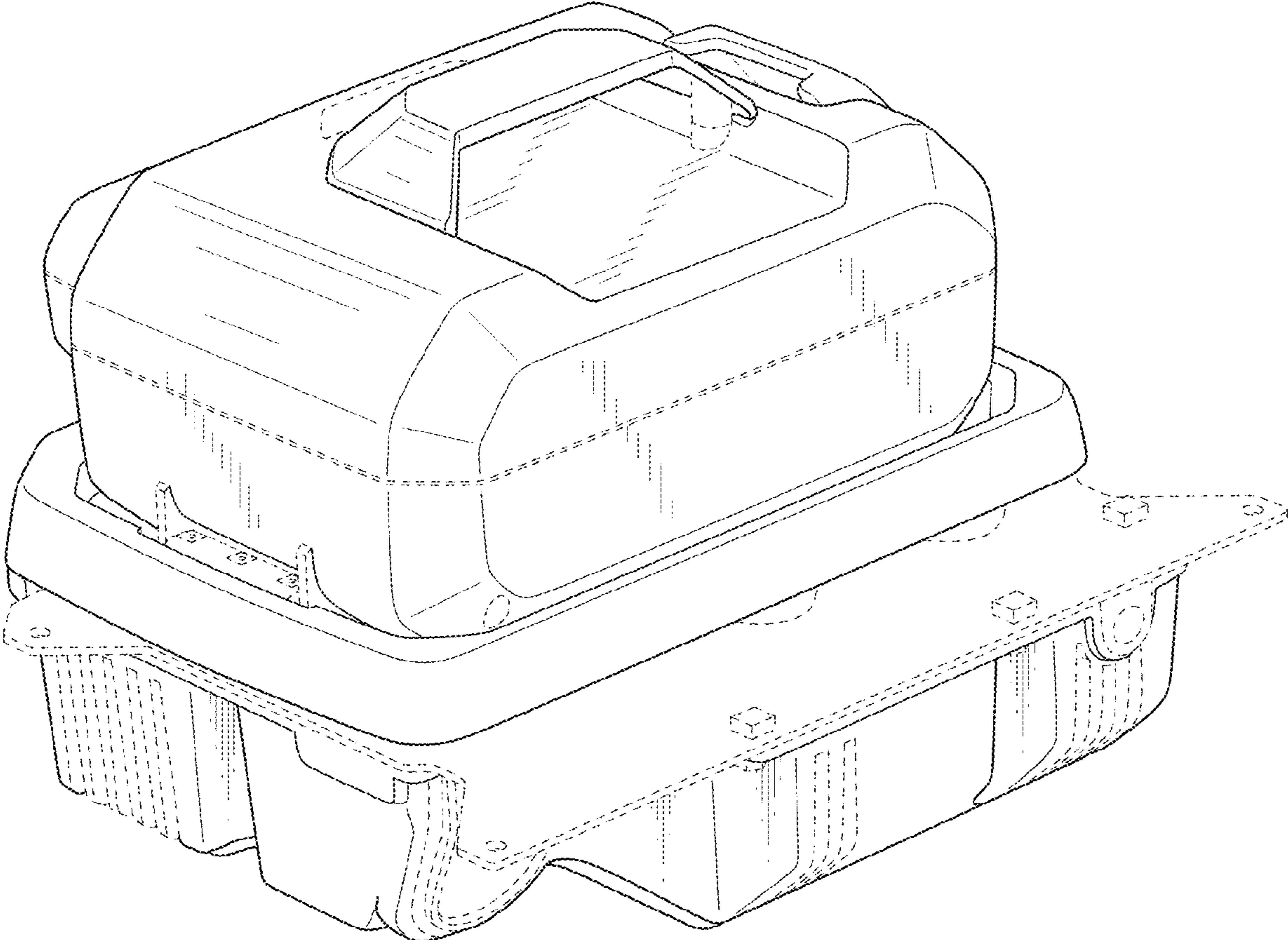

FIG. 4

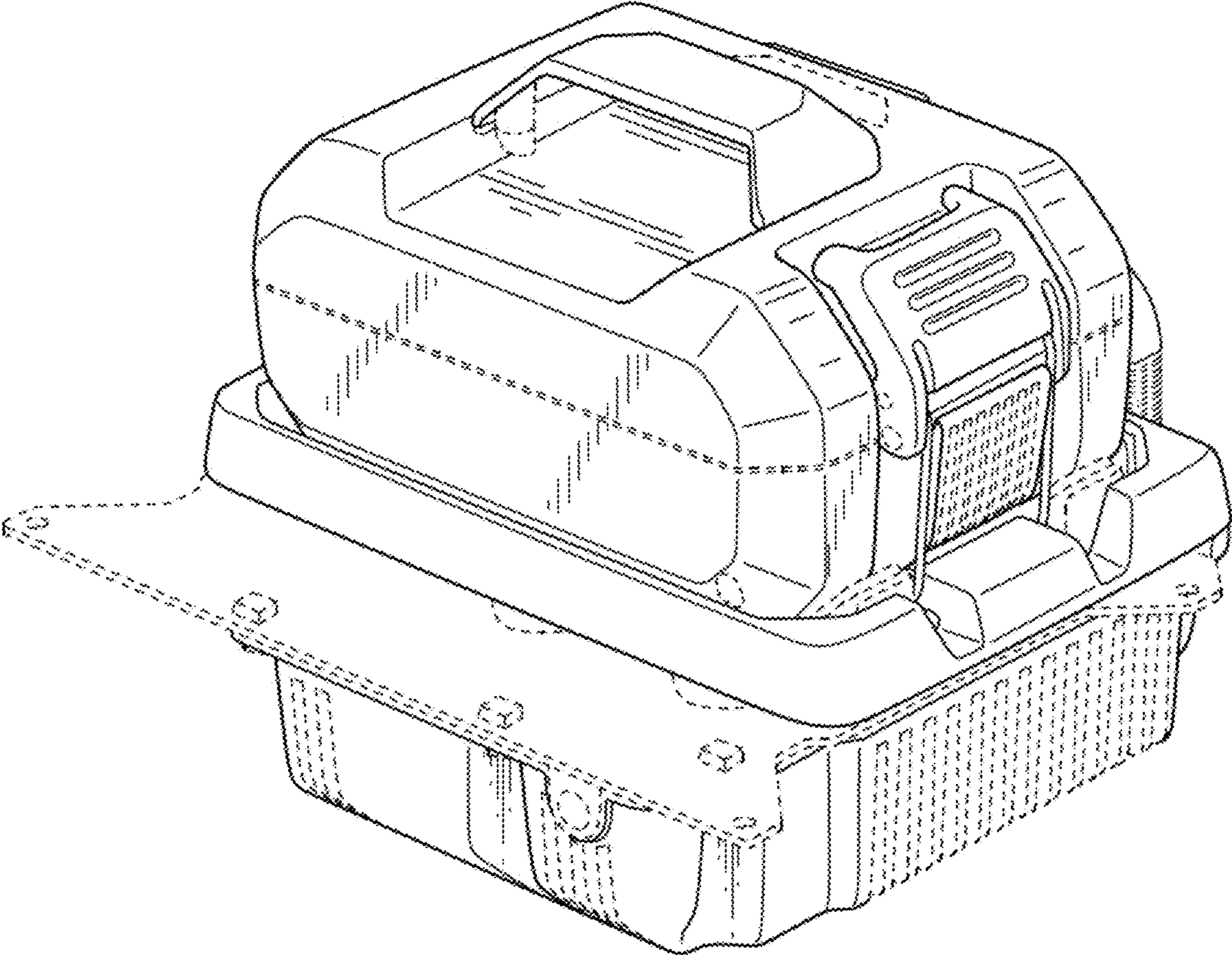

FIG. 5

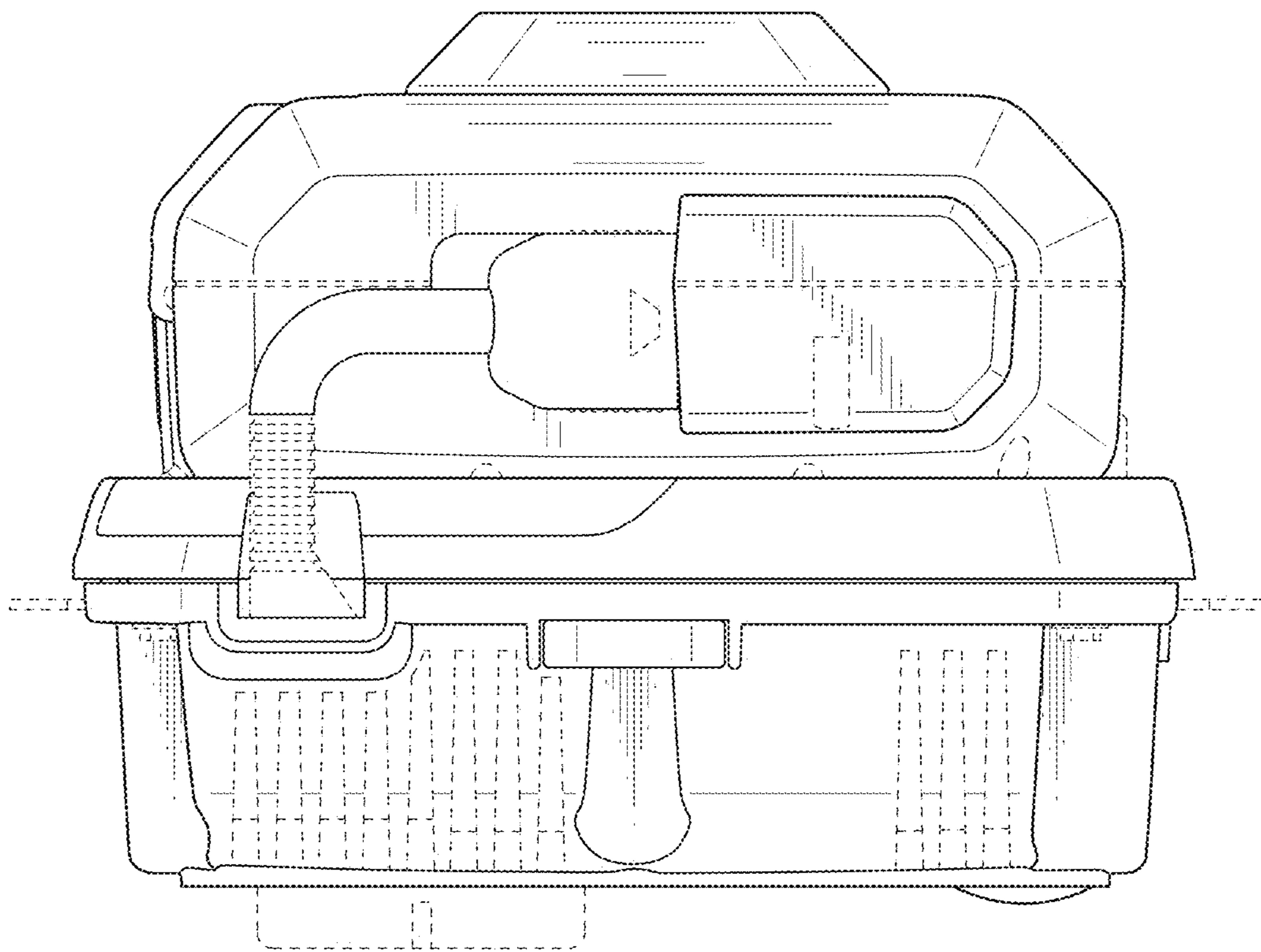

FIG. 6

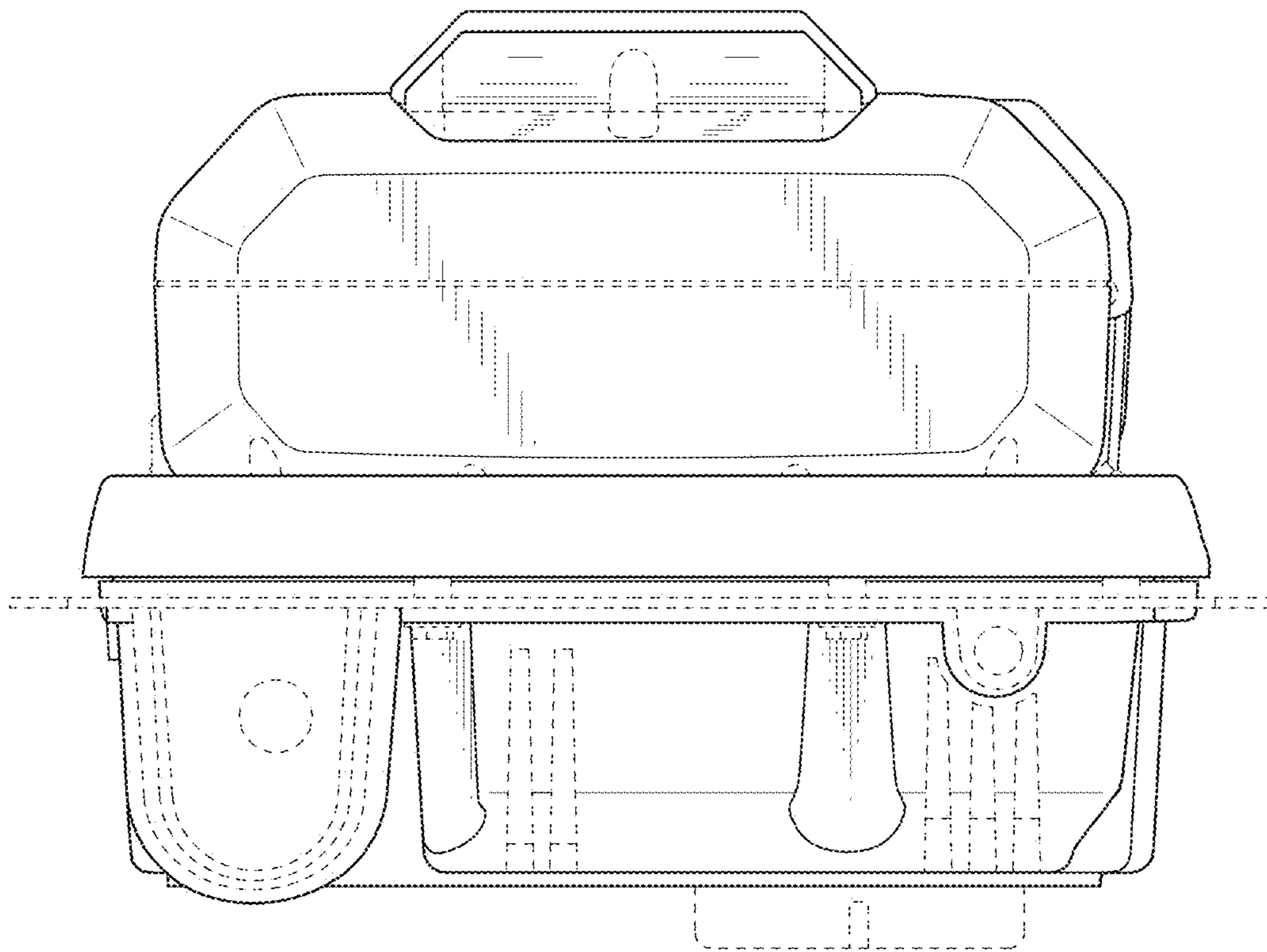

FIG. 7

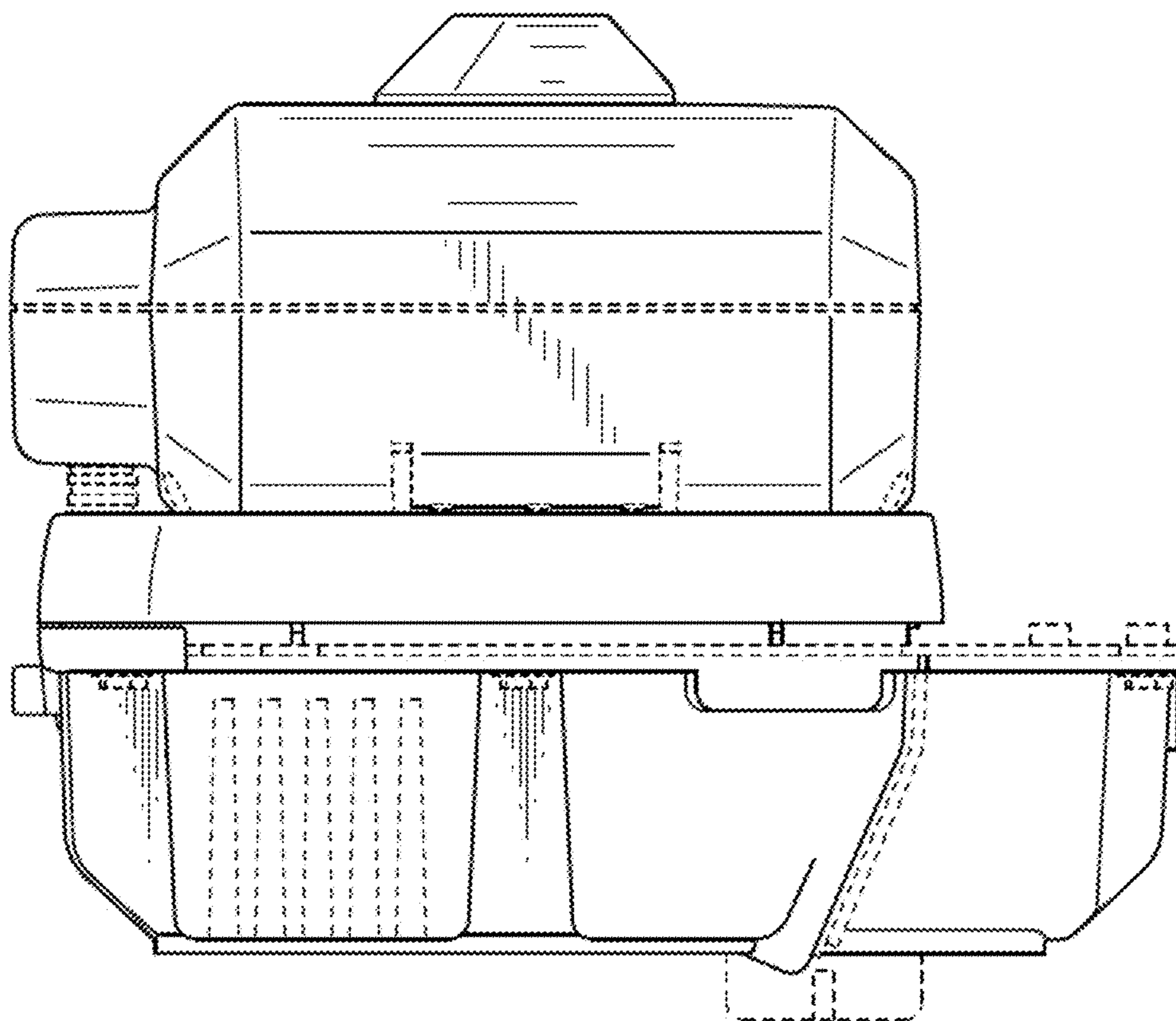

FIG. 8

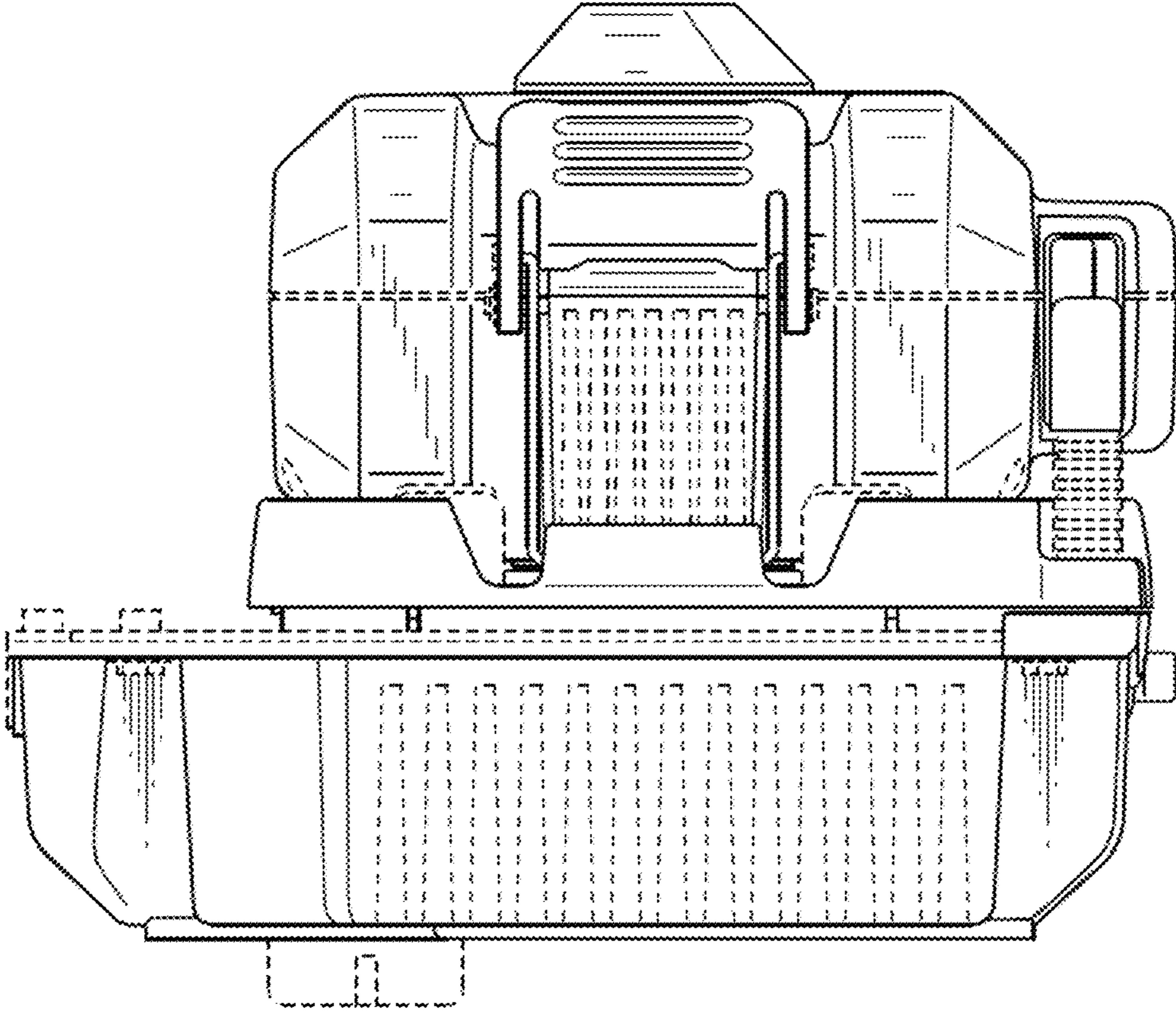

FIG. 9

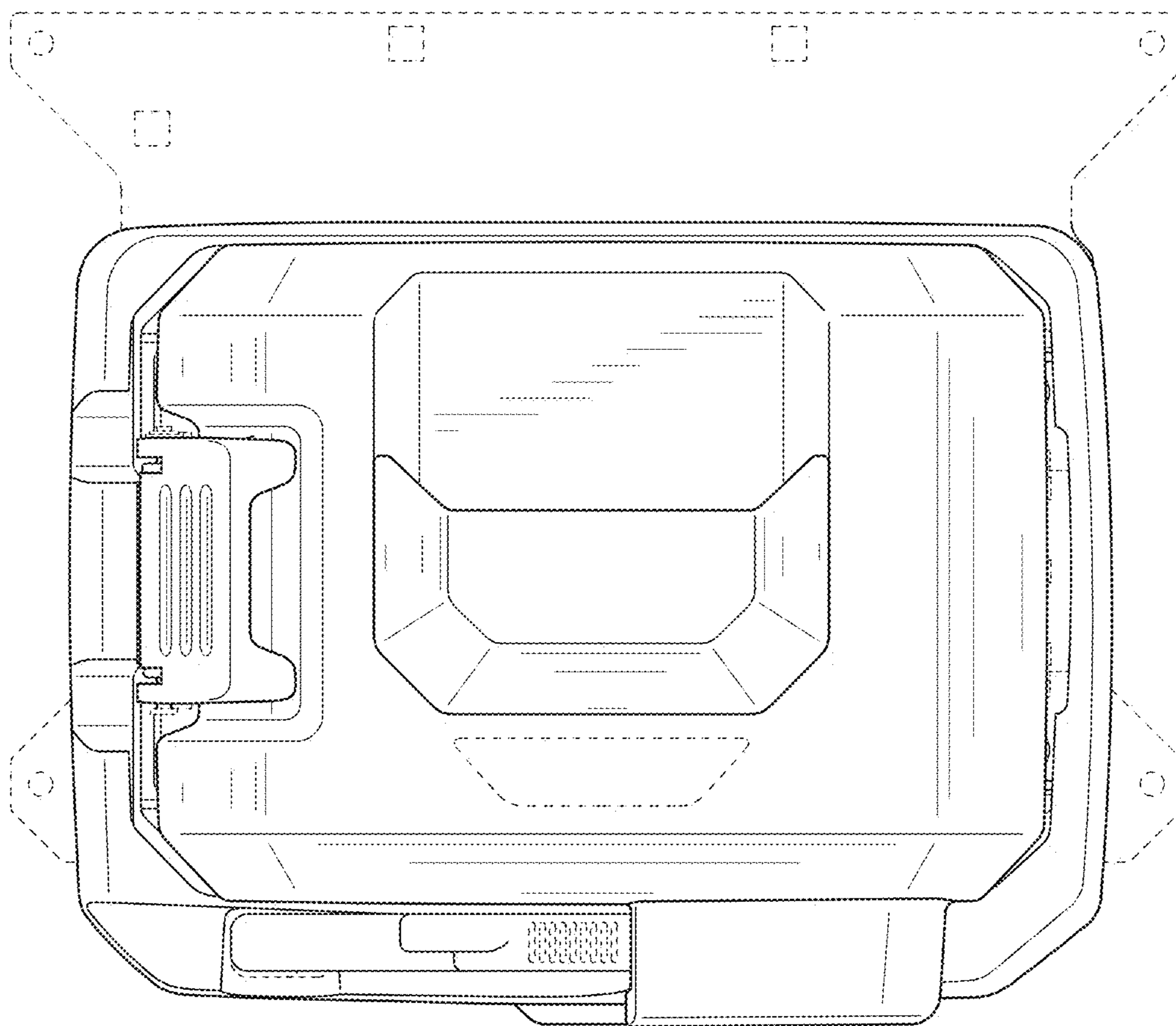

FIG. 10

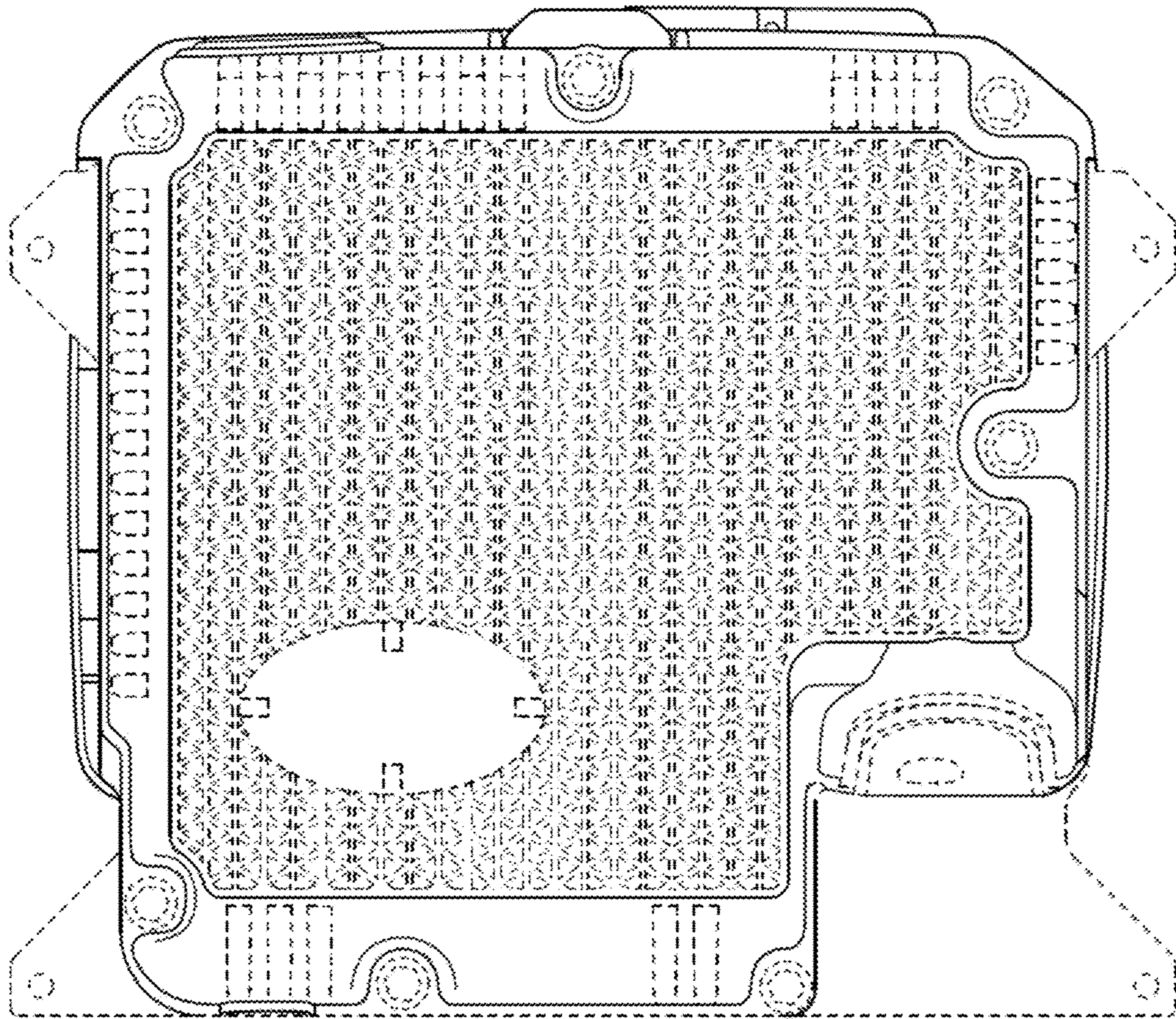

FIG. 11

