



US00D973347S

(12) **United States Design Patent**
Tatsumi

(10) **Patent No.:** **US D973,347 S**

(45) **Date of Patent:** **** Dec. 27, 2022**

(54) **GUITAR STRAP**

(71) Applicant: **Tatsumi Gakki Inc.**, Tokyo (JP)

(72) Inventor: **Akira Tatsumi**, Tokyo (JP)

(73) Assignee: **TATSUMI GAKKI INC.**, Tokyo (JP)

(**) Term: **15 Years**

(21) Appl. No.: **29/723,434**

(22) Filed: **Feb. 6, 2020**

(30) **Foreign Application Priority Data**

Aug. 6, 2019 (JP) 2019-017579

(51) **LOC (13) Cl.** **03-01**

(52) **U.S. Cl.**
USPC **D3/204**

(58) **Field of Classification Search**
USPC D3/204, 215; 224/257, 910; 84/327;
D17/20

CPC Y10T 24/316; G10G 5/005
See application file for complete search history.

(56) **References Cited**

U.S. PATENT DOCUMENTS

- 510,875 A * 12/1893 Adams A41F 1/00
24/301
- 523,063 A * 7/1894 Adams A41F 1/00
24/301
- 1,789,184 A * 1/1931 Lang G10G 5/005
24/129 C
- 3,057,526 A * 10/1962 Jaquith G10G 5/005
294/82.18
- 3,102,446 A * 9/1963 Raleigh G10G 5/005
D3/218
- 4,291,822 A * 9/1981 Simonds G10D 1/08
984/106
- 4,349,139 A * 9/1982 Oishi A45F 5/00
224/908

- 5,368,393 A * 11/1994 Normann A47F 13/085
294/170
- D393,362 S * 4/1998 Byers A45F 5/02
D3/204
- 7,028,871 B1 * 4/2006 Glover G10G 5/005
87/13
- 7,774,969 B1 * 8/2010 Silverman G09F 3/207
40/586

(Continued)

FOREIGN PATENT DOCUMENTS

JP D1568594 2/2017

Primary Examiner — Kevin K Rudzinski

Assistant Examiner — Amber J Rabie

(74) *Attorney, Agent, or Firm* — Calfee Halter & Griswold LLP

(57) **CLAIM**

The ornamental design of a guitar strap, as shown and described.

DESCRIPTION

FIG. 1 is a line drawing of a top/front/right/left perspective view of a guitar strap of the present design; FIG. 2 is a front elevational view thereof; FIG. 3 is a rear elevational view thereof; FIG. 4 is a top plan view thereof; FIG. 5 is a bottom plan view thereof; FIG. 6 is a right-side elevational view thereof; FIG. 7 is a left-side elevational view thereof; and, FIG. 8 is a top/front/right enlarged perspective view of a specific portion of a guitar strap of the present design.

The broken lines showing portions of the guitar are for illustrative purposes only and form no part of the claimed design.

The dot dash broken lines used in FIG. 8 represent the boundaries of the enlarged partial view and form no part of the claimed design.

1 Claim, 8 Drawing Sheets

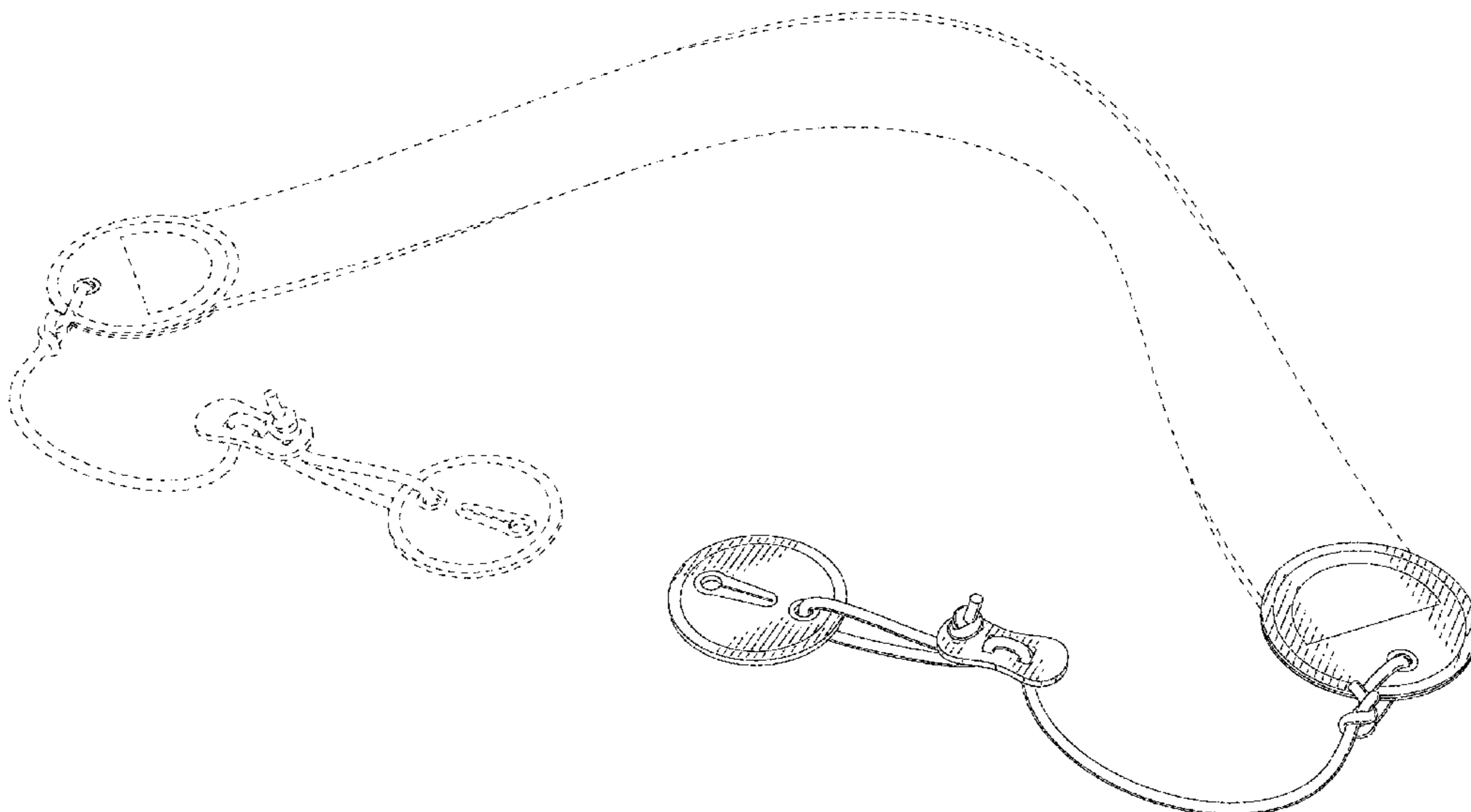

(56)

References Cited

U.S. PATENT DOCUMENTS

D805,729 S * 12/2017 Smith G10G 5/005
D2/706
2008/0061091 A1* 3/2008 Mailliard A45F 5/02
224/257

* cited by examiner

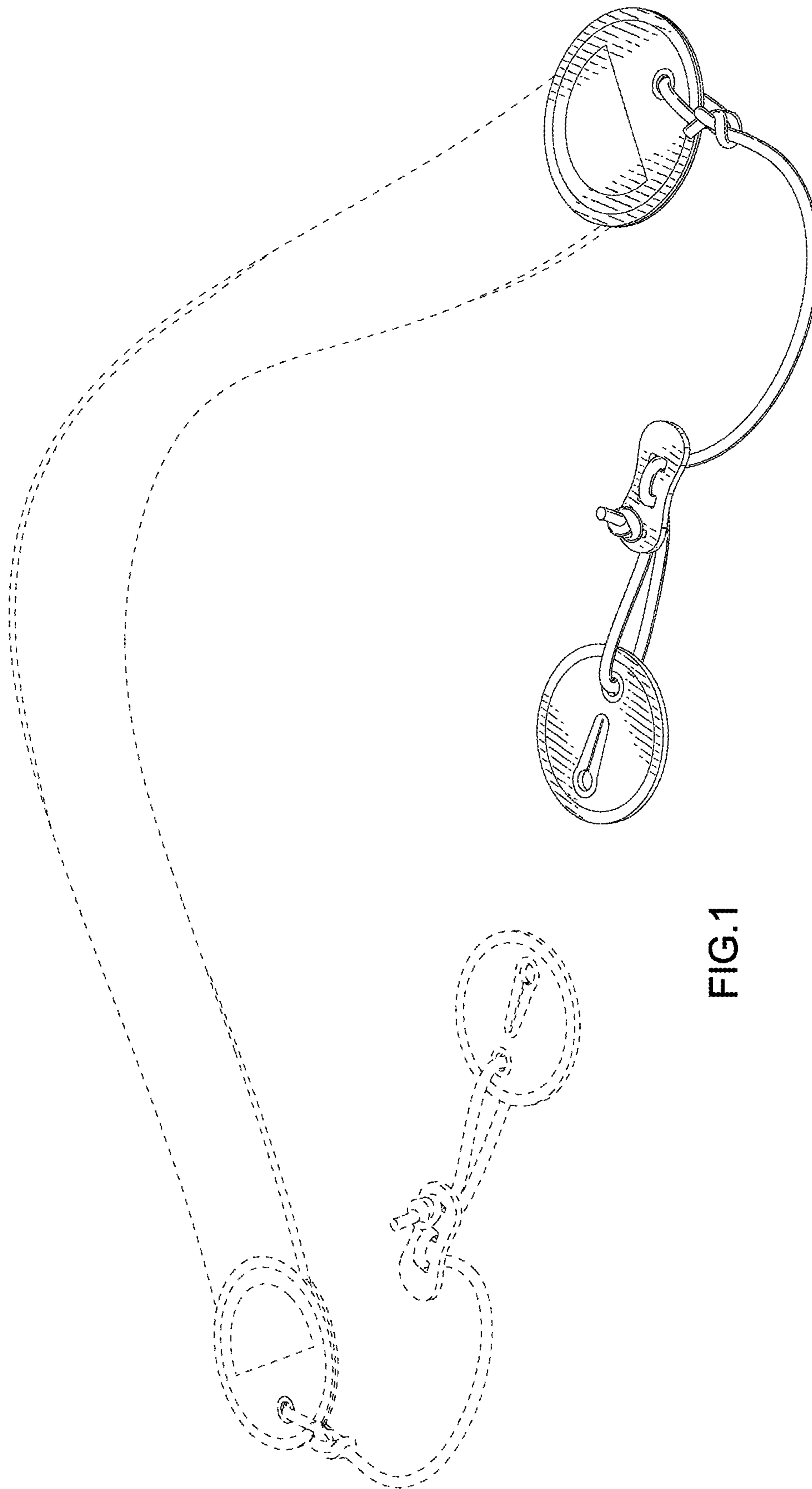

FIG.1

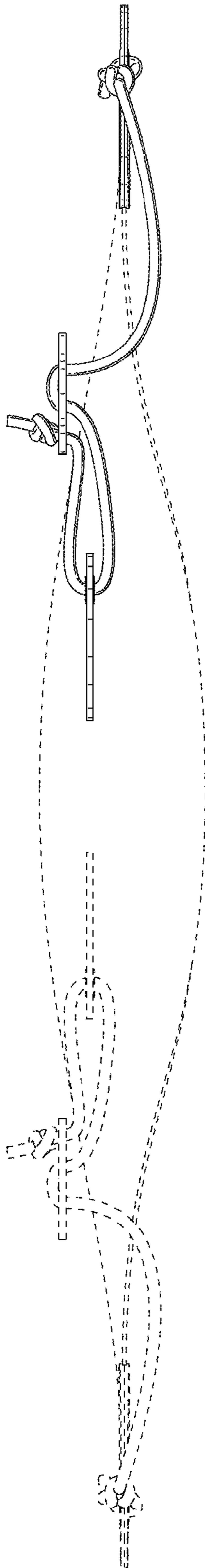

FIG.2

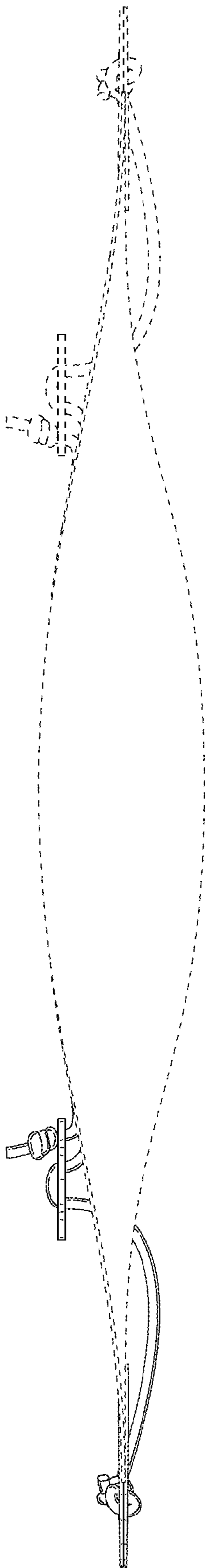

FIG.3

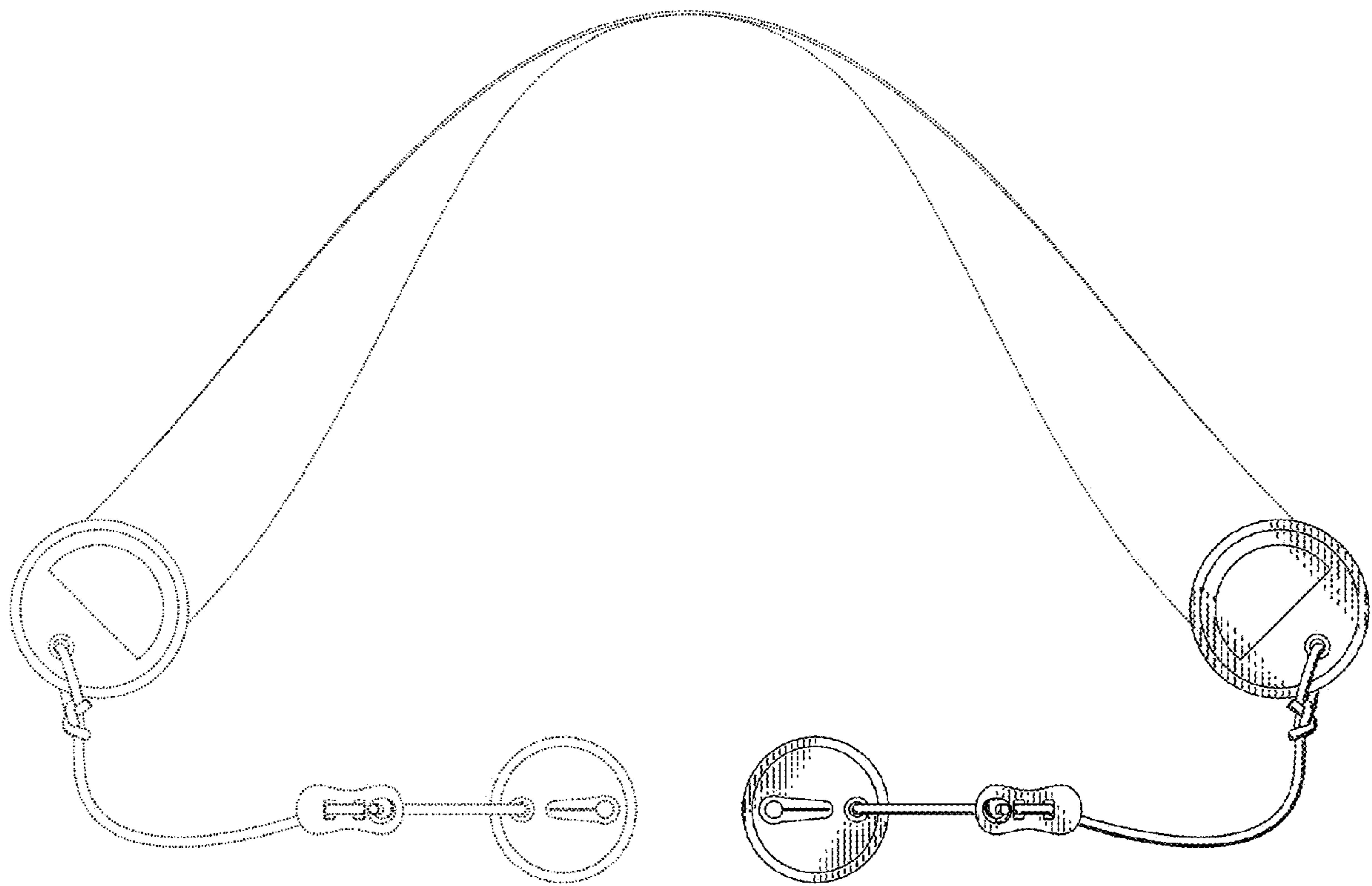

FIG. 4

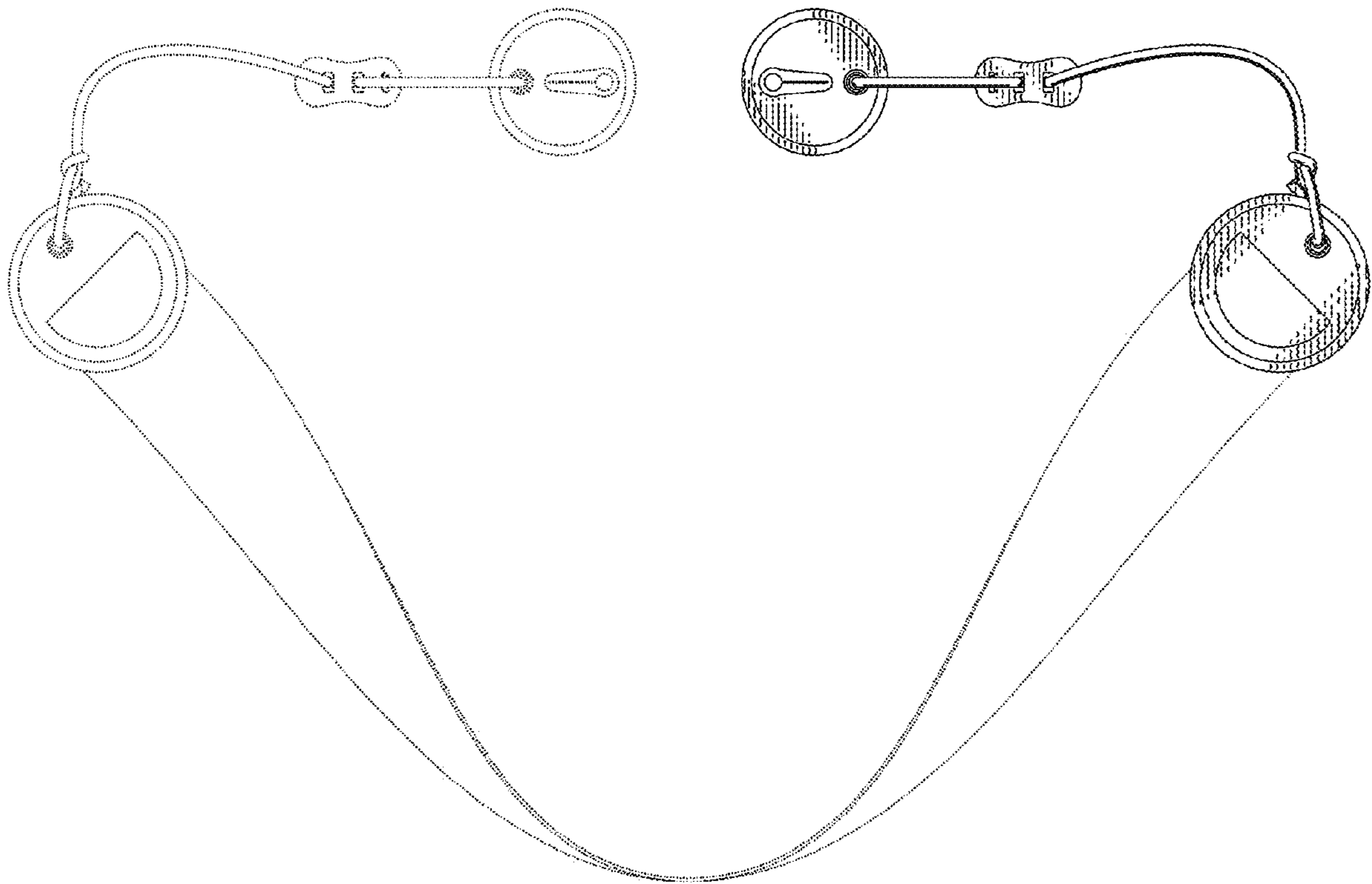

FIG. 5

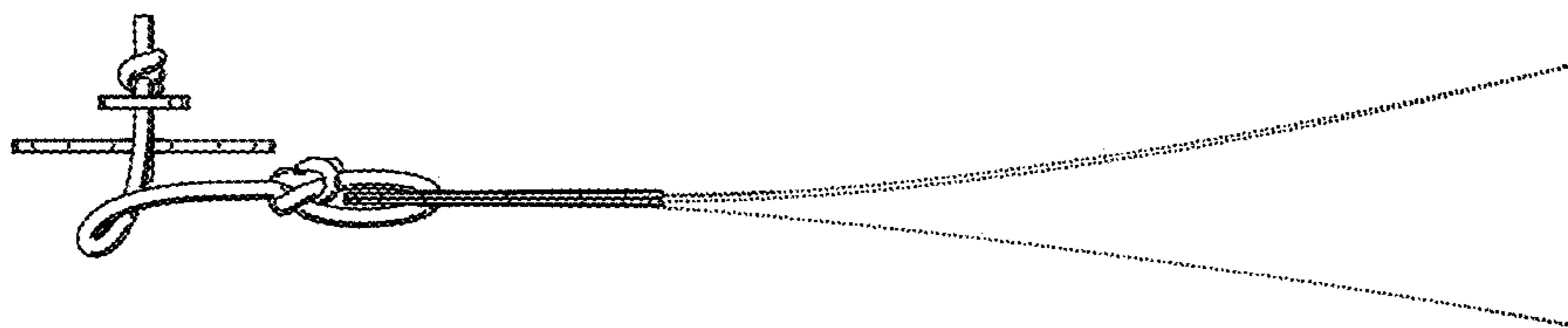

FIG. 6

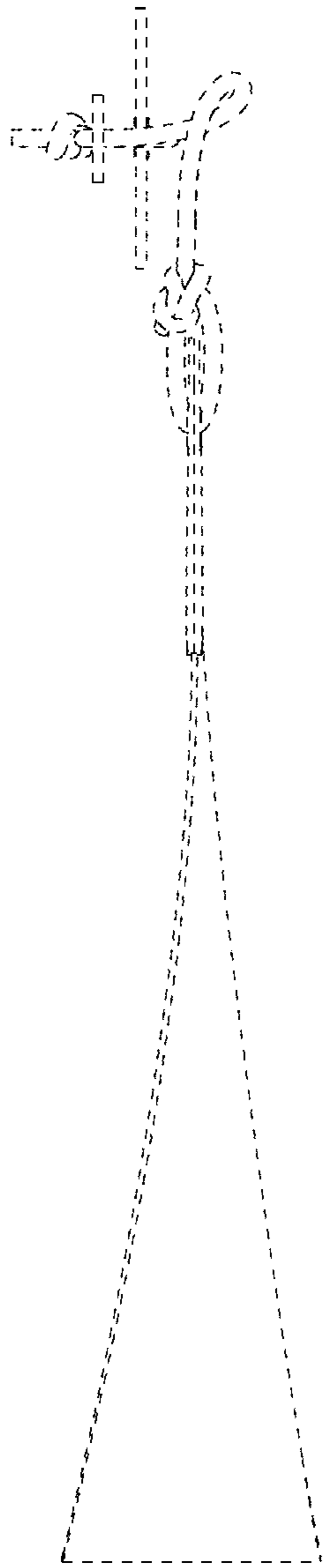

FIG. 7

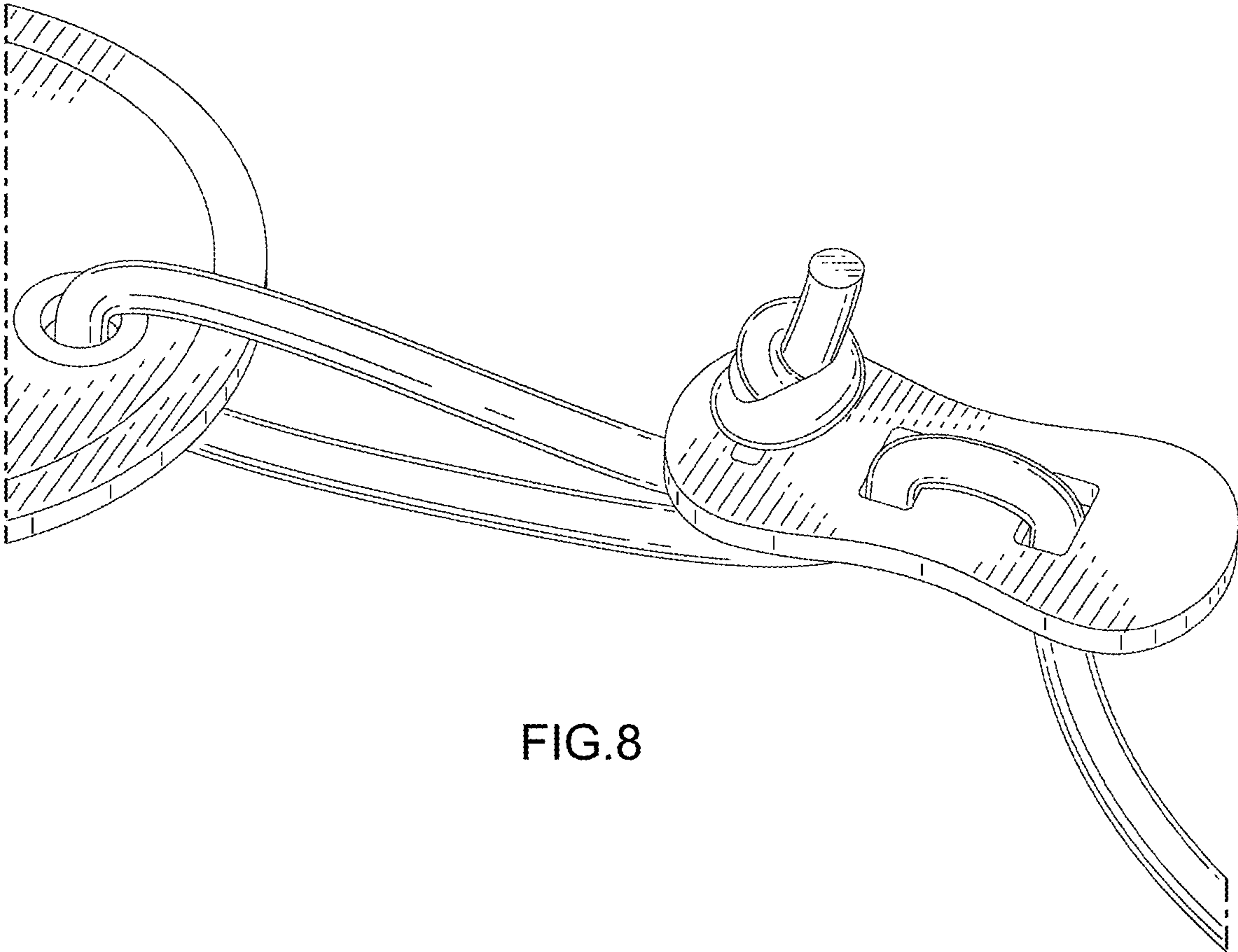

FIG.8