



US00D972994S

(12) **United States Design Patent** (10) **Patent No.:** **US D972,994 S**  
**Kim et al.** (45) **Date of Patent:** **\*\* Dec. 20, 2022**

(54) **VEHICLE WINDSHIELD**  
(71) Applicant: **Ford Global Technologies, LLC**,  
Dearborn, MI (US)  
(72) Inventors: **Soohyoung Kim**, Northville, MI (US);  
**Damon G. Depeyster**, Northville, MI  
(US); **Paul Wraith**, West Bloomfield,  
MI (US); **Albert Kim**, Northville, MI  
(US); **Heath W. Hilliard**, Detroit, MI  
(US)  
(73) Assignee: **Ford Global Technologies, LLC**,  
Dearborn, MI (US)  
(\*\*) Term: **15 Years**  
(21) Appl. No.: **29/770,520**  
(22) Filed: **Feb. 12, 2021**  
(51) **LOC (13) Cl.** ..... **12-16**  
(52) **U.S. Cl.**  
USPC ..... **D12/182**  
(58) **Field of Classification Search**  
USPC ..... D12/182, 183, 317  
CPC ..... B32B 3/00  
See application file for complete search history.

D919,524 S \* 5/2021 Wraith ..... D12/182  
D919,525 S \* 5/2021 Piaskowski ..... D12/182  
D919,526 S \* 5/2021 Wraith ..... D12/182  
D920,865 S \* 6/2021 Piaskowski ..... D12/182  
D932,402 S \* 10/2021 Piaskowski ..... D12/182  
D932,964 S \* 10/2021 Piaskowski ..... D12/182

**OTHER PUBLICATIONS**

Andre Smirnov, Leaked: 2022 Ford Maverick Truck? Could This Be the Next Ford Ranger or Bronco-Based Pickup?, <https://tfttruck.com/2020/04/leaked-2022-ford-maverick-truck-could-this-be-the-next-ford-ranger-or-bronco-based-pickup/> Apr. 30, 2020.

(Continued)

*Primary Examiner* — Susan E Krakower  
*Assistant Examiner* — Jerry Shiuan-Hua Hsu

(57) **CLAIM**

The ornamental design for a vehicle windshield, as shown and described.

**DESCRIPTION**

FIG. 1 is a front elevational view of a vehicle windshield showing our new design;  
FIG. 2 is a left side elevational view thereof;  
FIG. 3 is a right side elevational view thereof;  
FIG. 4 is a top plan view thereof;  
FIG. 5 is a bottom plan view thereof;  
FIG. 6 is a top, front and left side perspective view thereof; and,  
FIG. 7 is a top, front and right side perspective view thereof. The broken lines depict a boundary around the deemphasized elements, which illustrate portions of the vehicle windshield that form no part of the claimed design.

**1 Claim, 7 Drawing Sheets**

(56) **References Cited**  
U.S. PATENT DOCUMENTS  
D667,354 S \* 9/2012 Platto ..... D12/182  
D721,313 S \* 1/2015 Mays ..... D12/182  
D805,978 S \* 12/2017 Platto ..... D12/182  
D813,763 S \* 3/2018 Bucher ..... D12/182  
D813,764 S \* 3/2018 Bucher ..... D12/182  
D813,765 S \* 3/2018 Woodhouse ..... D12/182  
D813,766 S \* 3/2018 Woodhouse ..... D12/182  
D814,371 S \* 4/2018 Bucher ..... D12/182  
D821,276 S \* 6/2018 Gueler ..... D12/182  
D822,564 S \* 7/2018 Gueler ..... D12/182

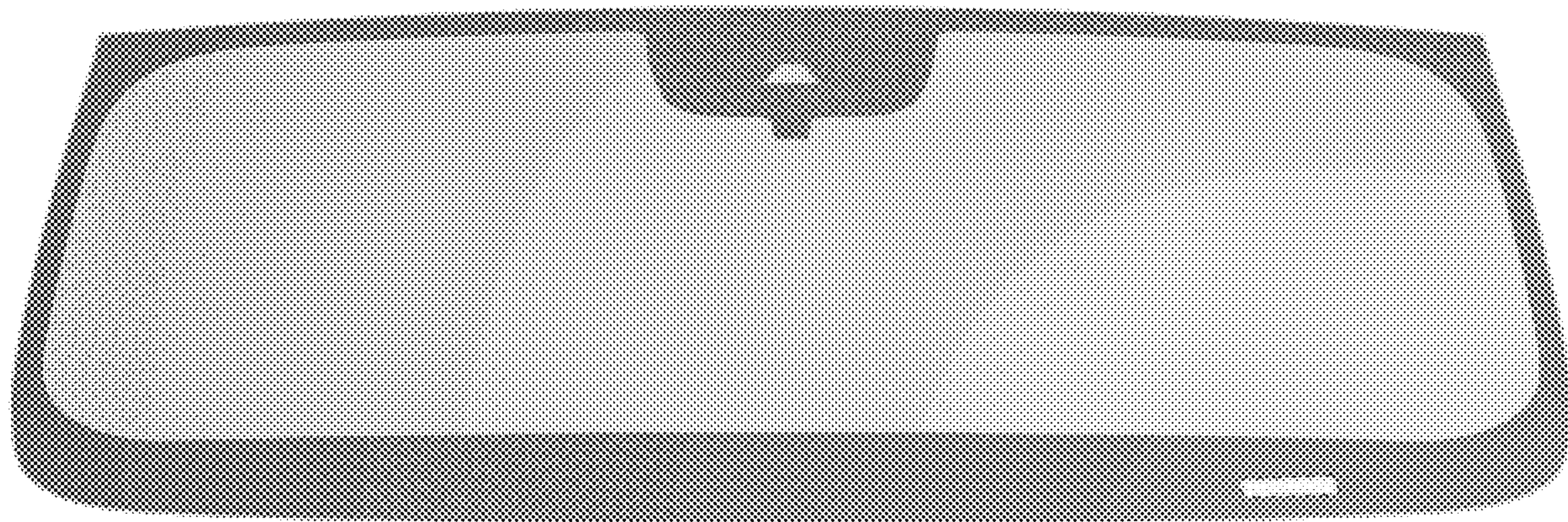

(56)

**References Cited**

OTHER PUBLICATIONS

Viknesh Vijayenthiran, 2022 Ford Maverick Spy Shots: Compact Pickup on the way, [https://www.motorauthority.com/news/1129703\\_2022-ford-maverick-spy-shots](https://www.motorauthority.com/news/1129703_2022-ford-maverick-spy-shots) Sep. 23, 2020.

Brett Foote, Ford Maverick Pickup Will Only Be Available In Four-Door Configuration, <https://fordauthority.com/2020/12/ford-maverick-pickup-will-only-be-available-in-four-door-configuration/> Dec. 7, 2020.

Chris Bruce, 2022 Ford Maverick Caught In Bare Metal, Revealing its Design, <https://www.motor1.com/news/458839/2022-ford-maverick-bare-metal/> Dec. 7, 2020.

MR Robot, Ford Maverick Unibody Fully Revealed!, <https://www.mavericktruckclub.com/forum/threads/ford-maverick-unibody-fully-revealed.13/> Dec. 7, 2020.

Chris Bruce, 2022 Ford Maverick May Only Be Available In Four-Door Super Crew Body, <https://www.motor1.com/news/459229/2022-ford-maverick-super-crew/> Dec. 9, 2020.

Paul A. Eisenstein, Return of the Ford Maverick—But This Time It's Going to Be a Compact Pickup, <https://www.thedetroitbureau.com/2020/12/return-of-the-ford-maverick-but-this-time-its-going-to-be-a-compact-pickup/> Dec. 9, 2020.

Allison Barfield, The 2022 Ford Maverick Looks Bigger Than Expected, <https://www.motorbiscuit.com/the-2022-ford-maverick-looks-bigger-than-expected/> Dec. 12, 2020.

Alexander Stoklosa, 2022 Ford Maverick: Here It Is, Looking Compact and Surprisingly Trucky, <https://www.motortrend.com/news/2022-ford-maverick-spy-photo-factory-details/> Jan. 8, 2021.

Josh Byrnes, 2022 Ford Maverick: Everything We Know About the Blue Oval's Baby Truck, <https://www.carscoops.com/2021/01/2022-ford-maverick-everything-we-know-about-the-blue-ovals-baby-truck/> Jan. 30, 2021.

\* cited by examiner

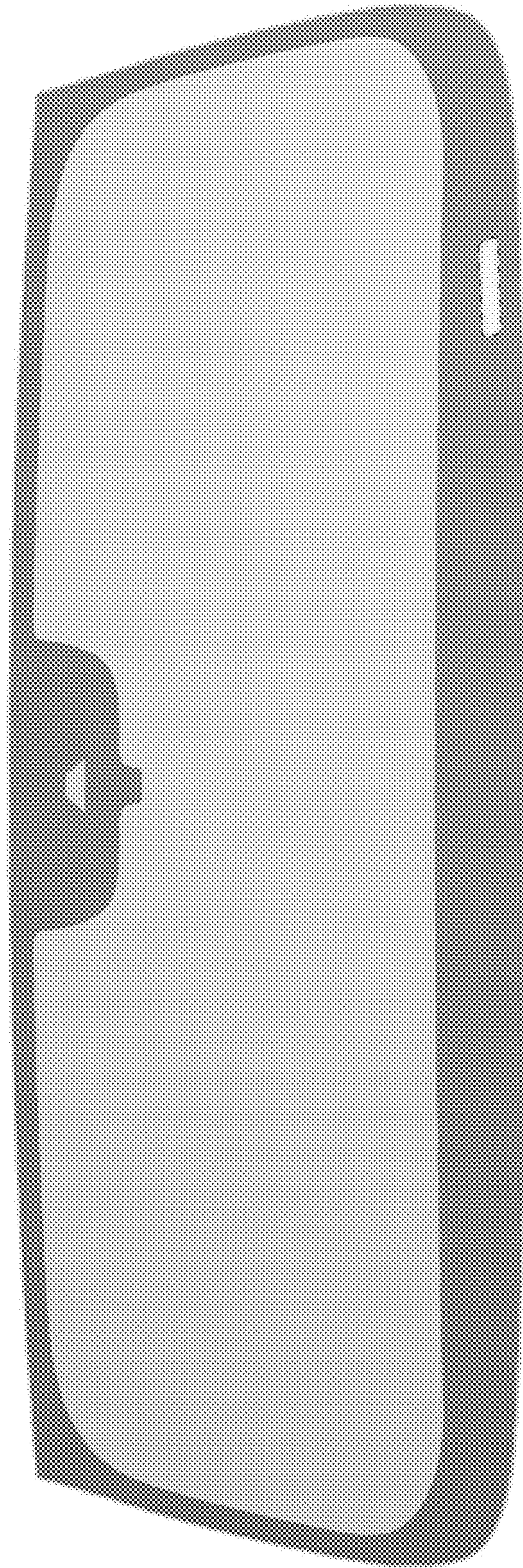

Fig. 1

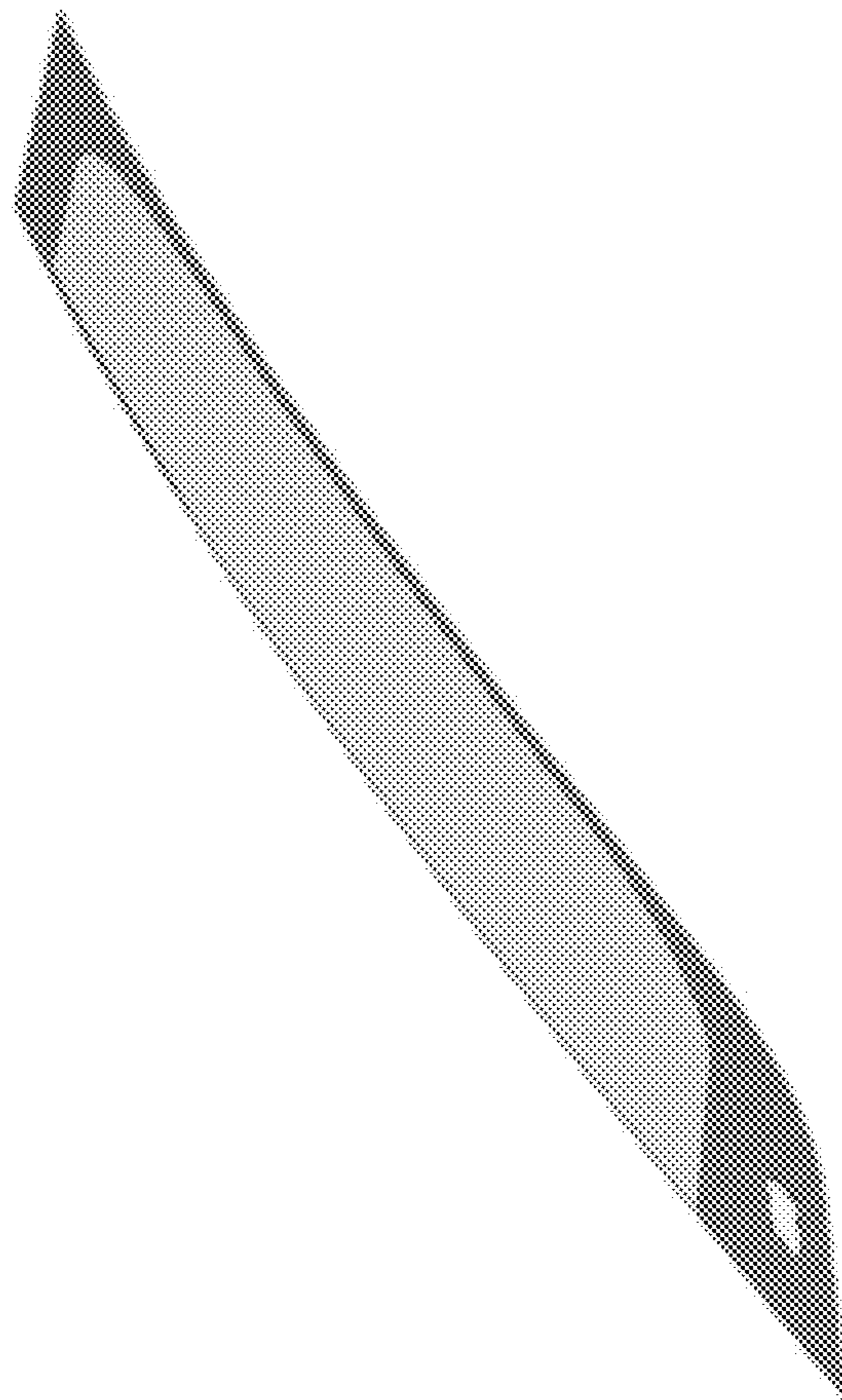

Fig. 2

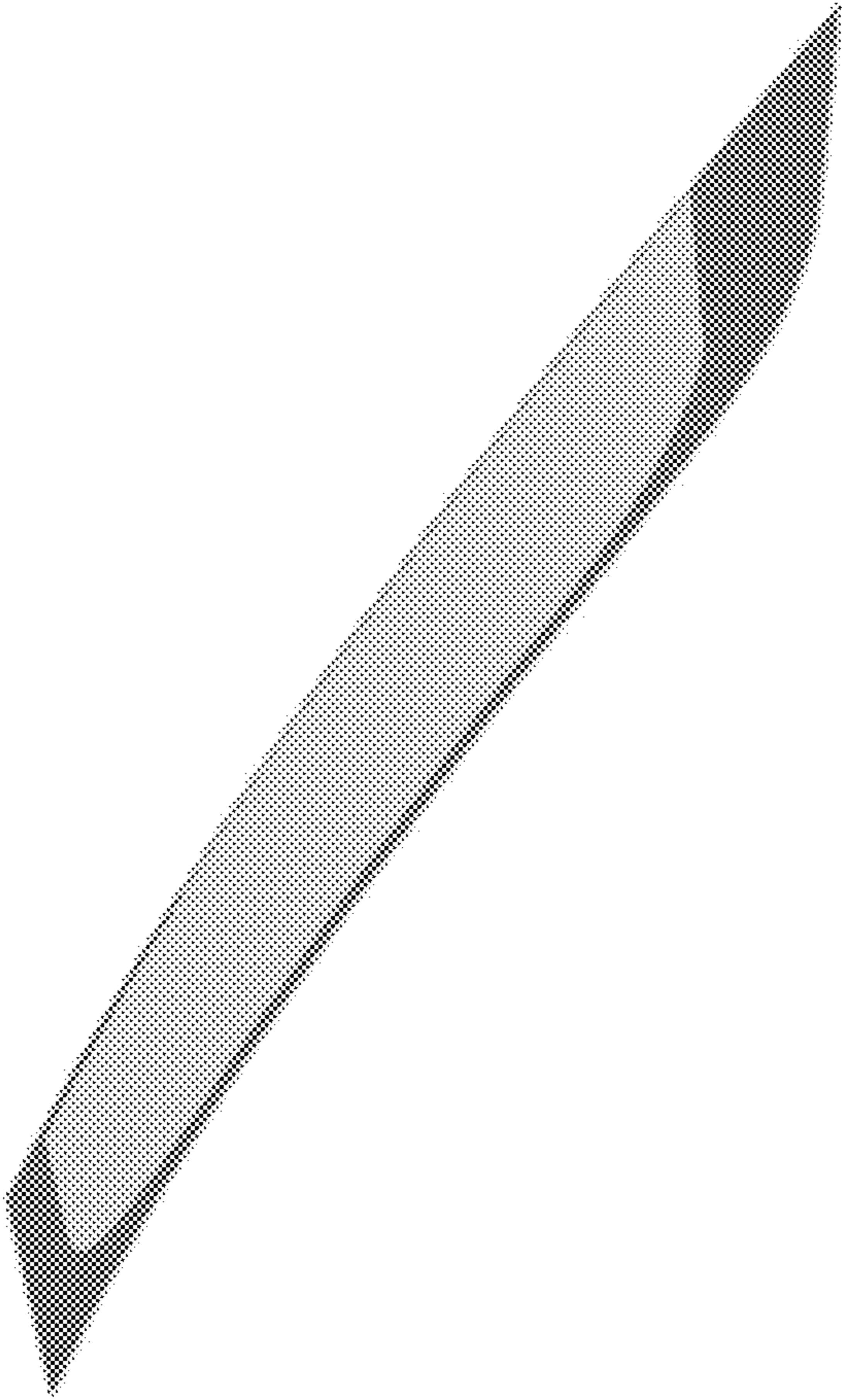

Fig. 3

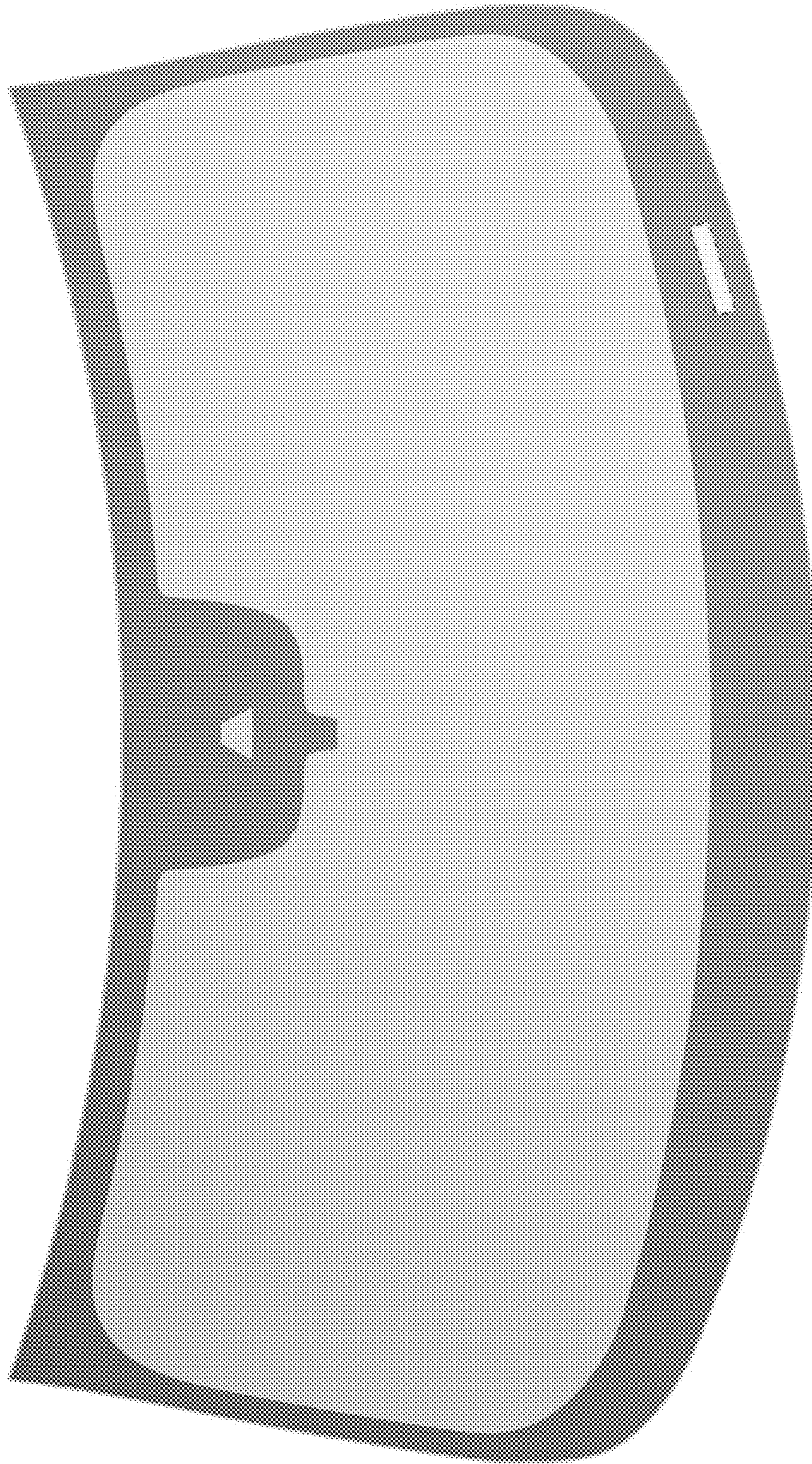

Fig.4

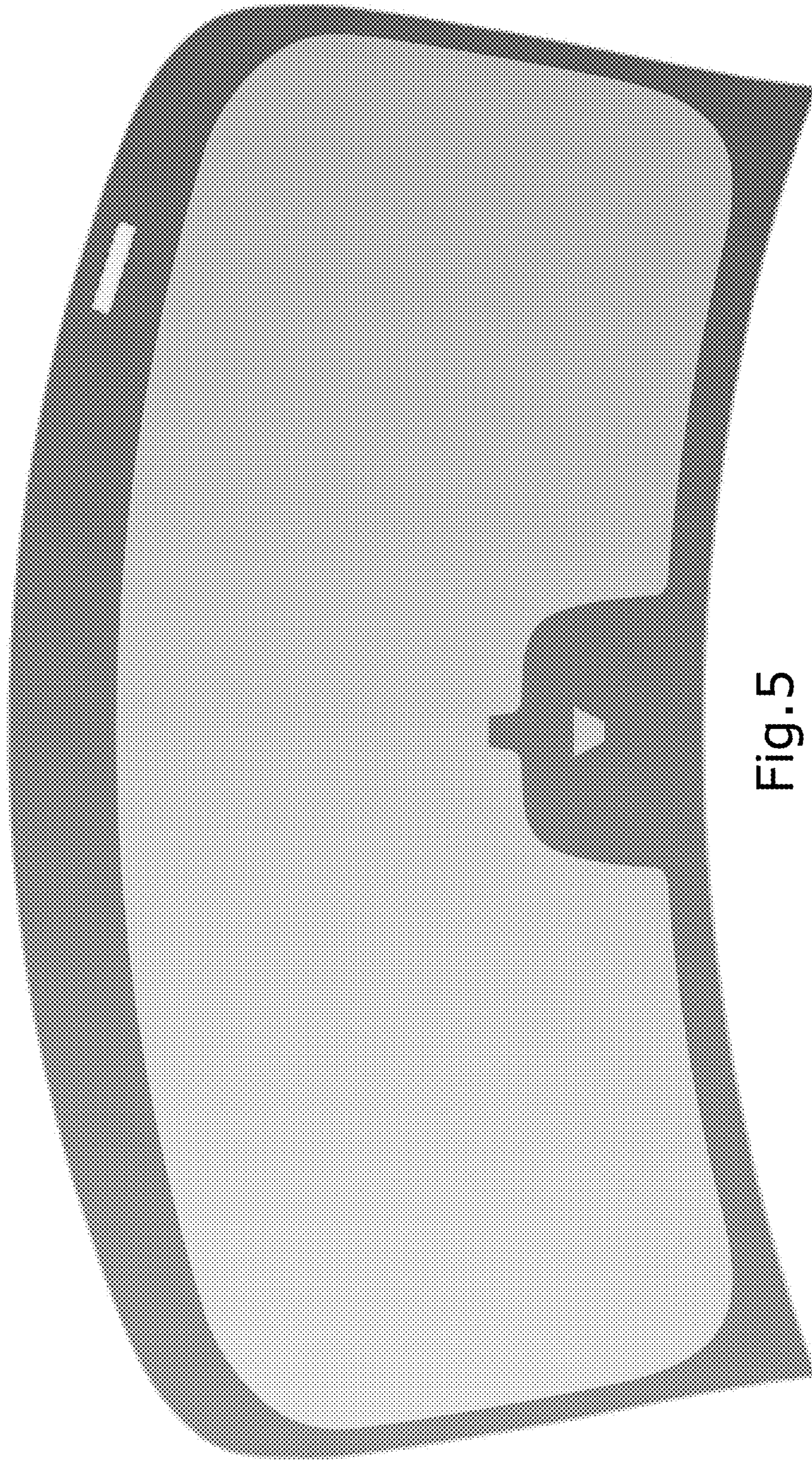

Fig. 5

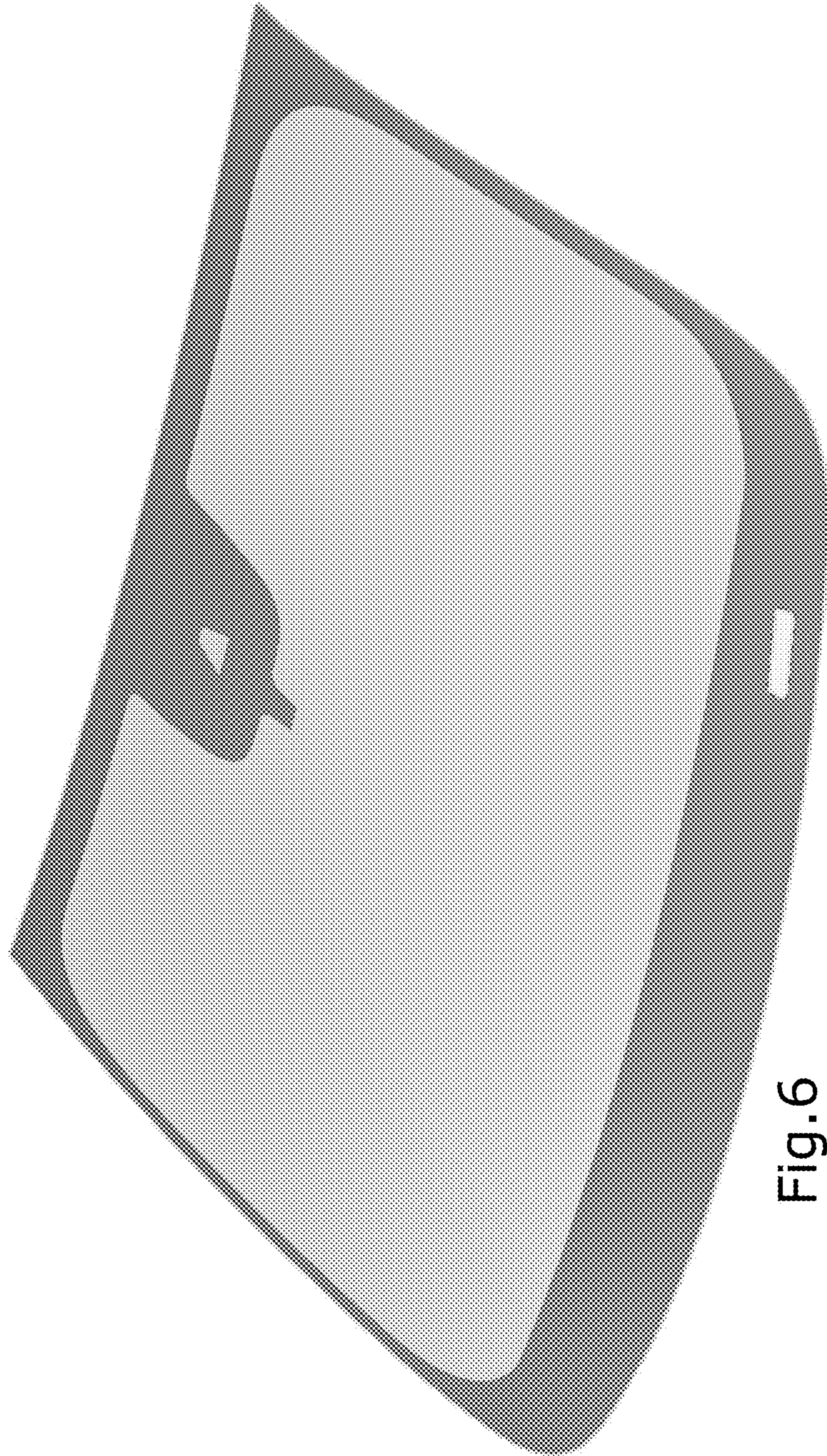

Fig.6



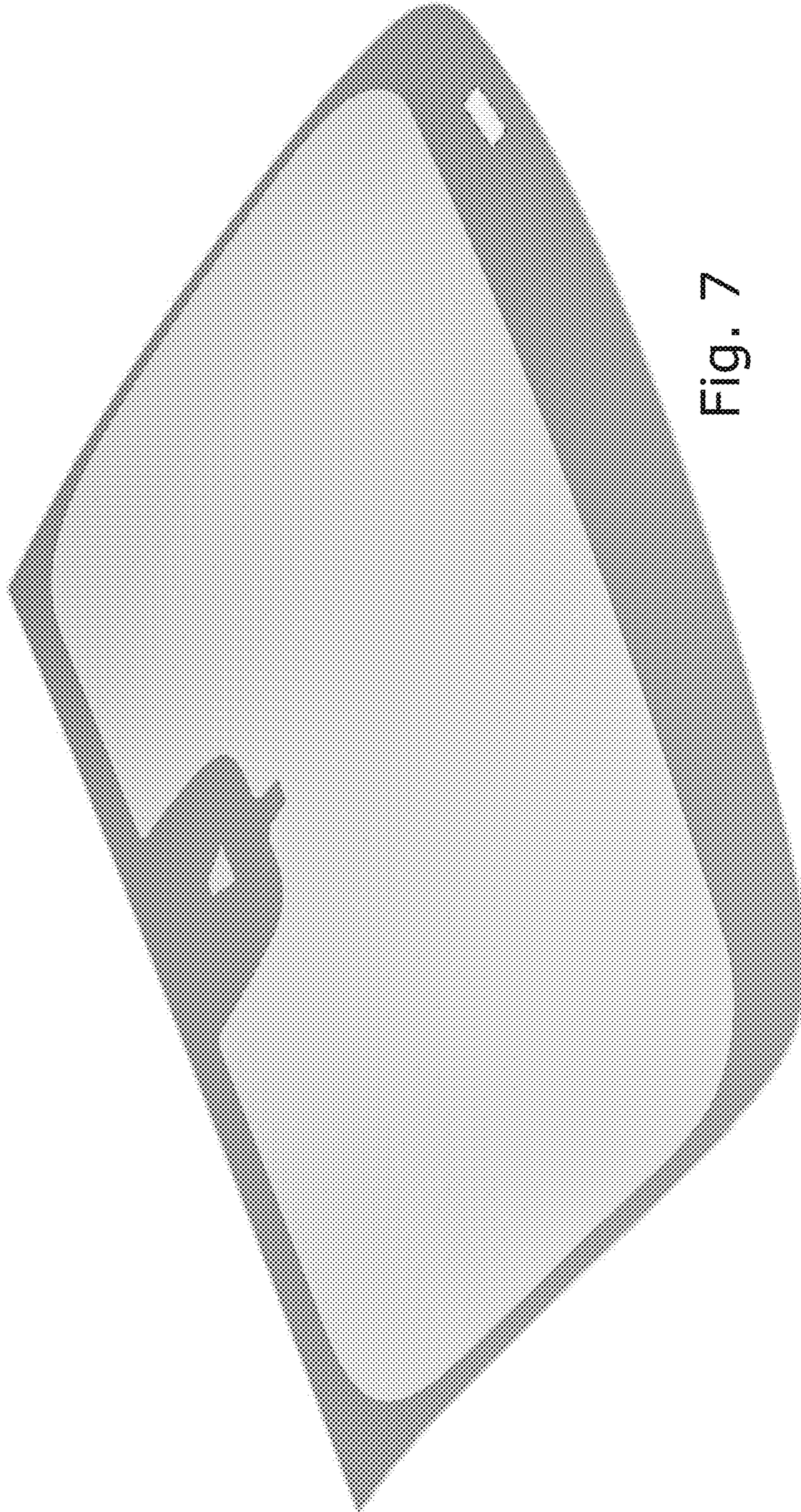

Fig. 7