

US00D972454S

(12) **United States Design Patent**  
**Wang**

(10) **Patent No.:** **US D972,454 S**  
(45) **Date of Patent:** **\*\* Dec. 13, 2022**

(54) **AERIAL VEHICLE**  
(71) Applicant: **Liming Wang**, Zhangzhou (CN)  
(72) Inventor: **Liming Wang**, Zhangzhou (CN)

D891,298 S \* 7/2020 Zhao ..... D12/16.1  
D904,226 S \* 12/2020 Zhao ..... D12/16.1  
D953,201 S \* 5/2022 Costier ..... B64C 27/50  
D12/16.1  
D964,887 S \* 9/2022 Lukashov ..... D12/16.1

(\*\*) Term: **15 Years**

**OTHER PUBLICATIONS**

(21) Appl. No.: **29/749,328**

X-11 Stratosphere Sky Rider Quadcopter Drone with Wi-Fi Camera (DRW311), posted [online], [retrieved Oct. 4, 2022]. Date not available. Retrieved from internet, <https://gpx.com/sky-rider/sky-rider-quadcopter-drone-w-wi-fi-camera-drw311.html> (Year: N/A).\*

(22) Filed: **Sep. 4, 2020**

(51) **LOC (13) Cl.** ..... **12-06**

\* cited by examiner

(52) **U.S. Cl.**

*Primary Examiner* — Christian P. McLean

USPC ..... **D12/16.1**; D21/436; D21/441

*Assistant Examiner* — Jessica Lynn Devilbiss

(58) **Field of Classification Search**

USPC ..... D12/16.1, 319–345; D21/436, 441, 443,  
D21/444, 446, 447, 448, 449, 450  
CPC ..... B64C 2201/141; B64C 2201/20; B64C  
2201/027; B64C 1/40

(57) **CLAIM**

The ornamental design for an aerial vehicle, as shown and described.

See application file for complete search history.

**DESCRIPTION**

(56) **References Cited**

FIG. 1 is a perspective view of an aerial vehicle showing my new design;  
FIG. 2 is another perspective view thereof;  
FIG. 3 is a front elevational view thereof;  
FIG. 4 is a rear elevational view thereof;  
FIG. 5 is a left side elevational view thereof;  
FIG. 6 is a right side elevational view thereof;  
FIG. 7 is a top plan view thereof; and,  
FIG. 8 is a bottom plan view thereof.  
The broken lines in the drawings depict portions of the aerial vehicle that form no part of the claimed design.

**U.S. PATENT DOCUMENTS**

D783,727 S \* 4/2017 Xiao ..... D21/441  
D793,482 S \* 8/2017 Wang ..... D21/441  
D798,961 S \* 10/2017 Li ..... D21/441  
D814,350 S \* 4/2018 Joo ..... D12/16.1  
D814,385 S \* 4/2018 Zhao ..... D12/328  
D814,973 S \* 4/2018 Li ..... D12/16.1  
D816,581 S \* 5/2018 Zhao ..... D12/328  
D860,047 S \* 9/2019 Gan ..... D12/16.1  
D862,360 S \* 10/2019 Liang ..... D12/328  
D884,554 S \* 5/2020 Chen ..... D12/16.1

**1 Claim, 8 Drawing Sheets**

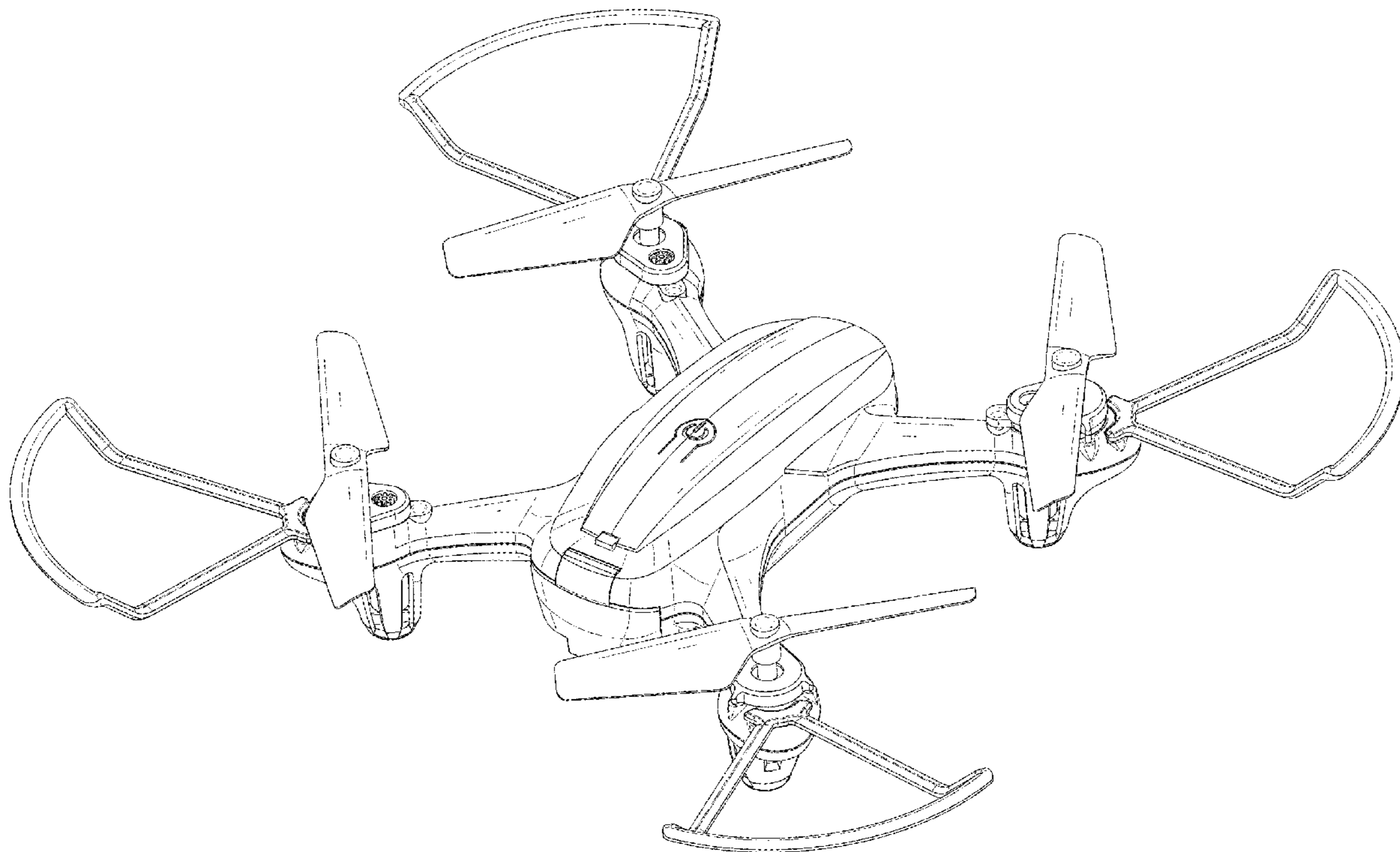

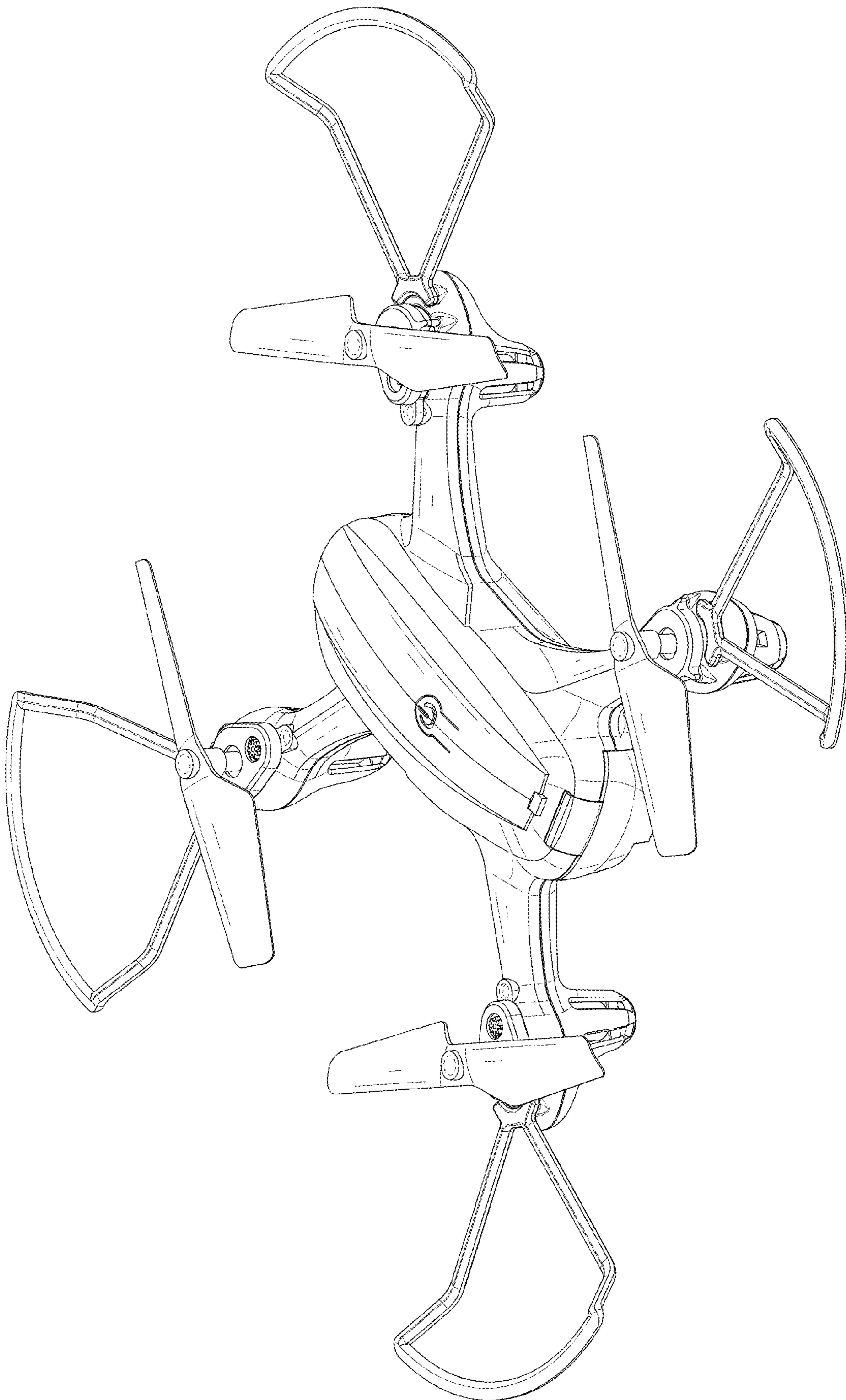

FIG. 1

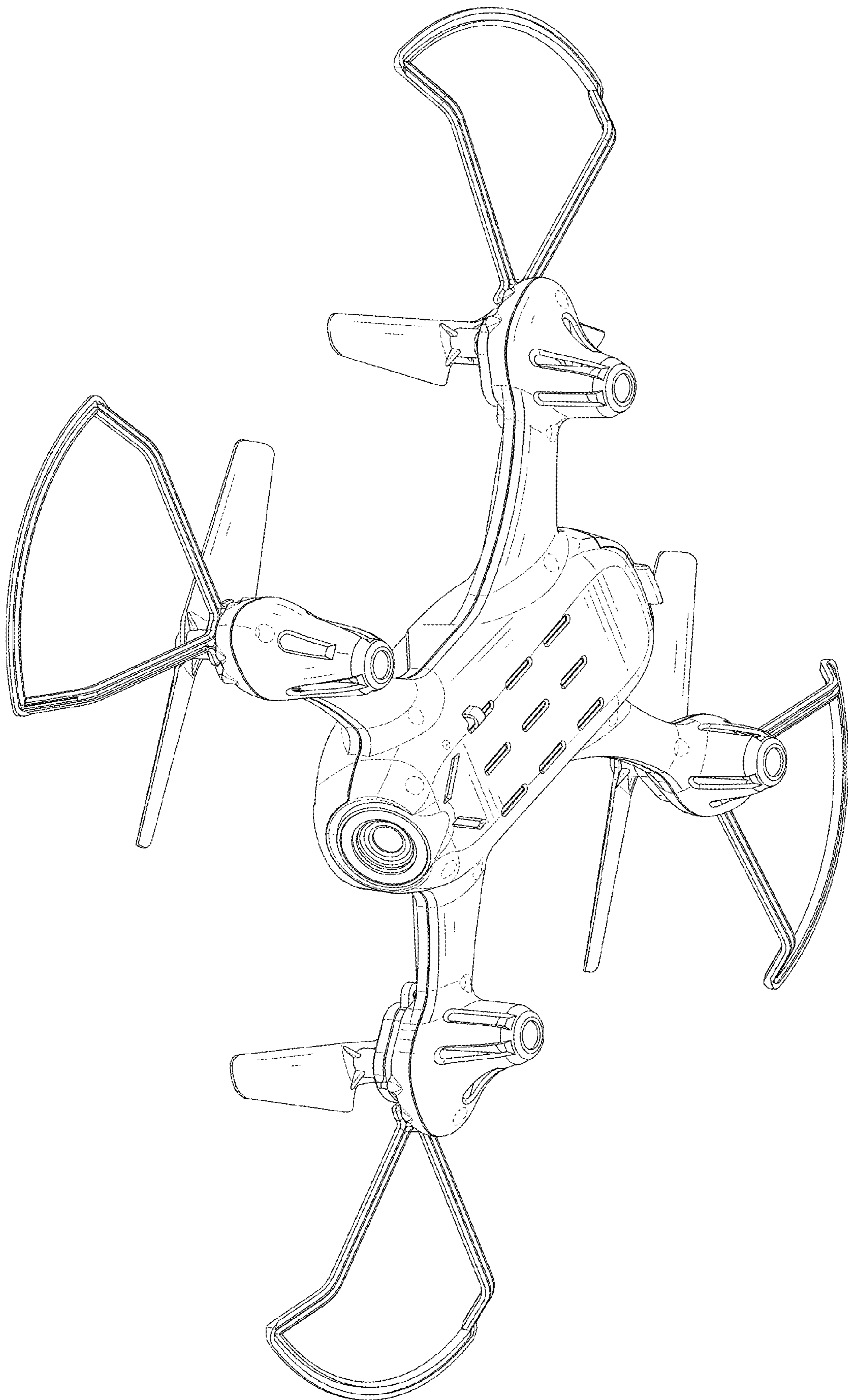

FIG. 2

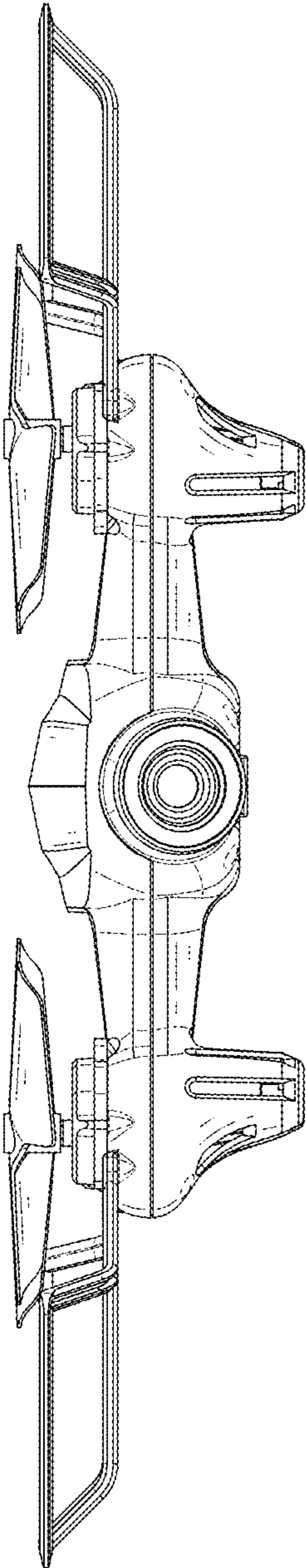

FIG. 3

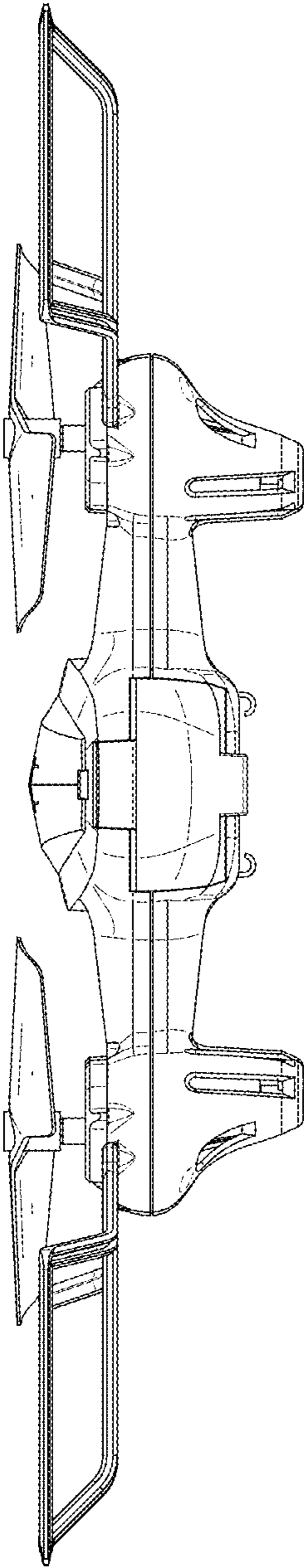

FIG. 4

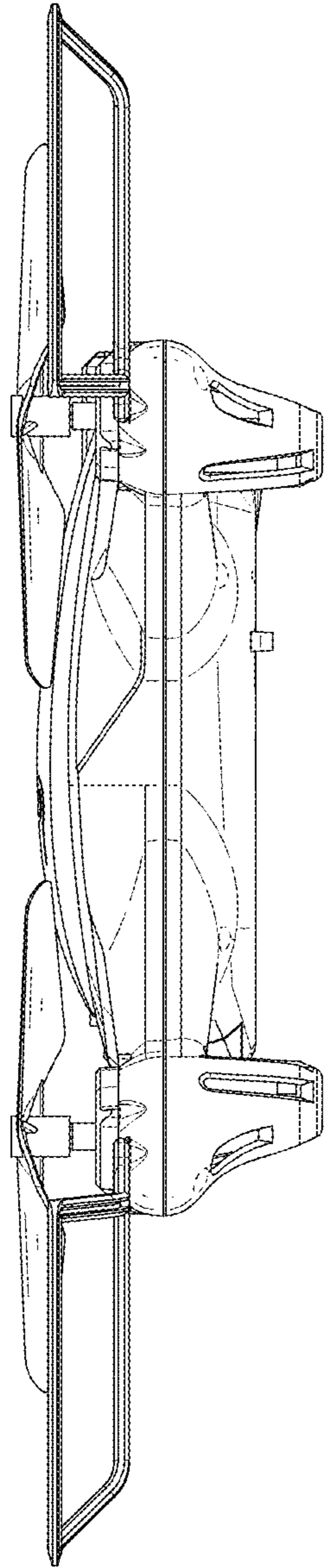

FIG. 5

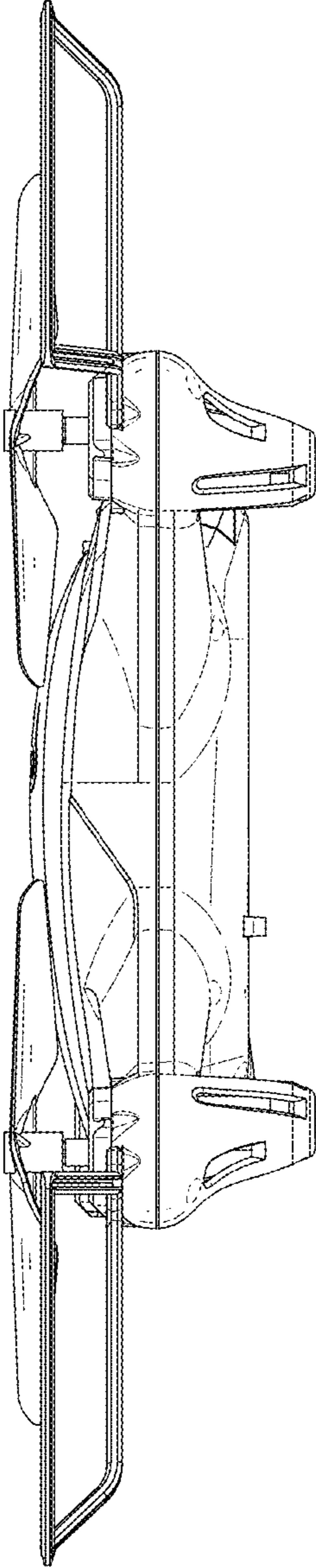

FIG. 6

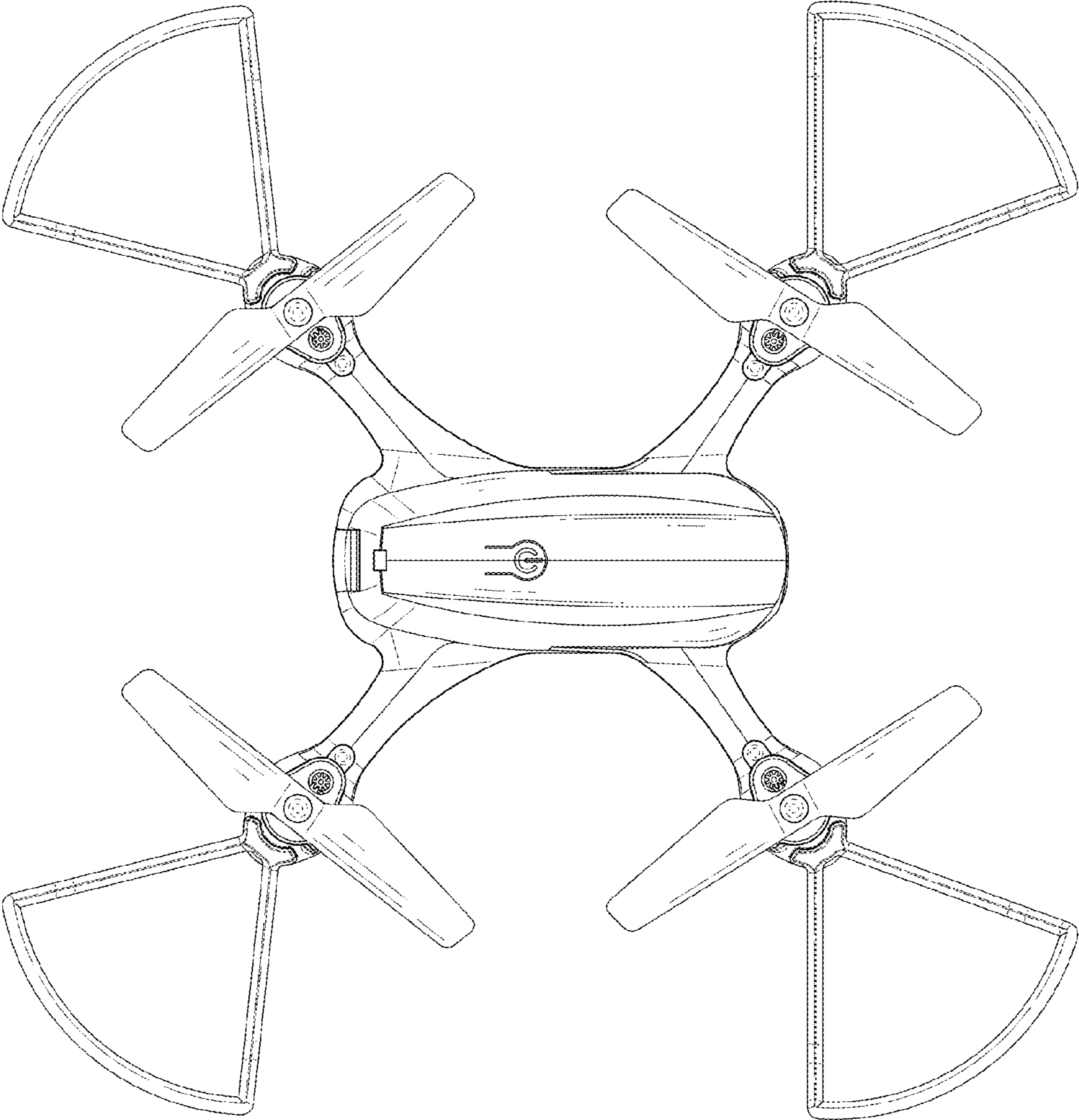

FIG. 7



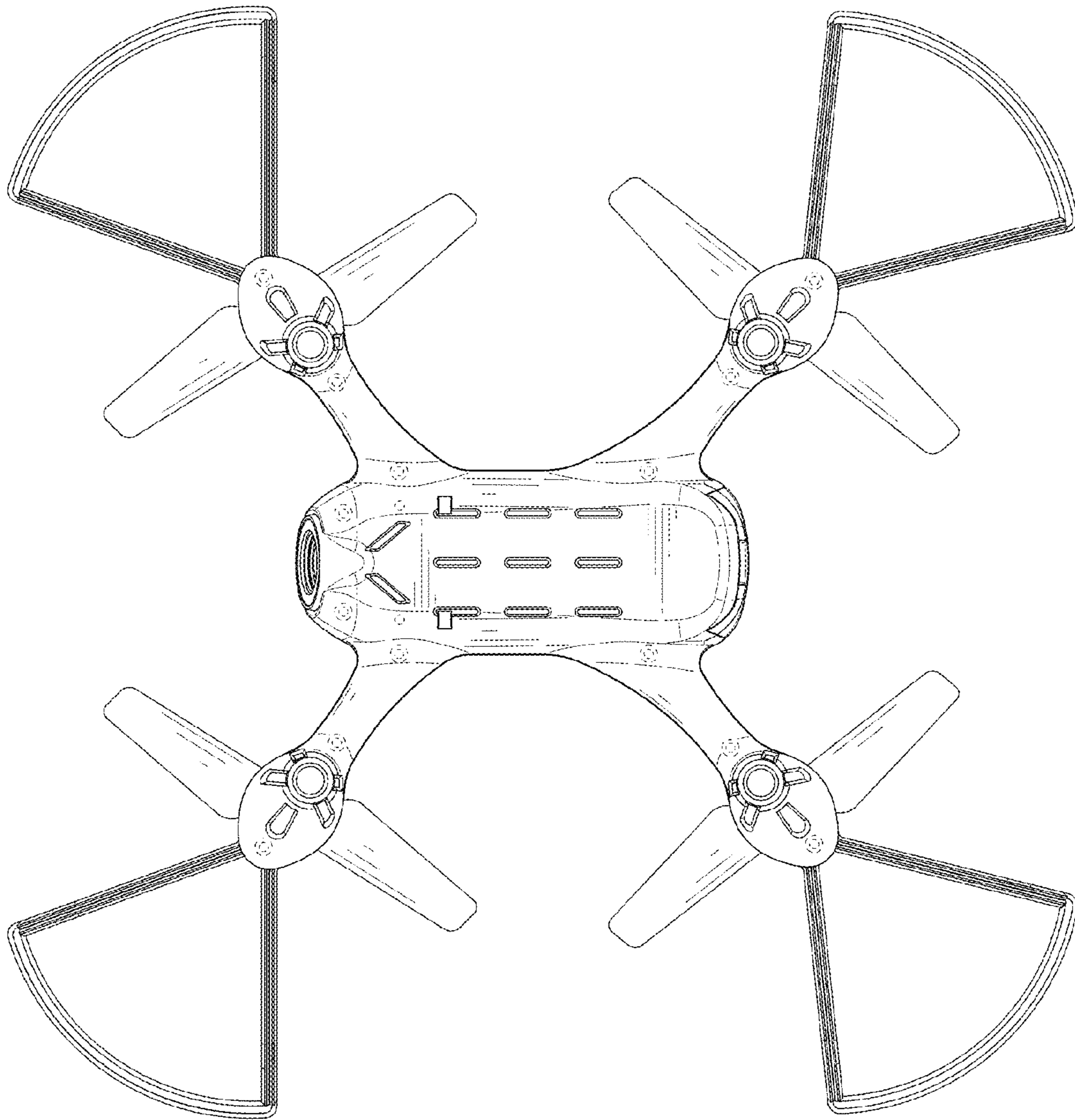

FIG. 8