



US00D972435S

(12) **United States Design Patent** (10) **Patent No.:** **US D972,435 S**  
**Du Mond** (45) **Date of Patent:** **\*\* Dec. 13, 2022**

(54) **JEWELRY BAND**  
(71) Applicant: **Cyril Studio**, West Hartford, CT (US)  
(72) Inventor: **Leila Du Mond**, West Hartford, CT (US)  
(73) Assignee: **Cyril Studio**, West Hartford, CT (US)  
(\*\*) Term: **15 Years**  
(21) Appl. No.: **29/725,332**  
(22) Filed: **Feb. 24, 2020**  
(51) **LOC (13) Cl.** ..... **11-01**  
(52) **U.S. Cl.**  
USPC ..... **D11/34**  
(58) **Field of Classification Search**  
USPC ..... D11/1, 7, 8, 26-39, 79, 91, 92, 86  
CPC ..... A44C 9/00; A44C 9/0007; A44C 9/0014;  
A44C 9/0023; A44C 9/003; A44C  
9/0038; A44C 9/0046; A44C 9/0053;  
A44C 9/0061; A44C 9/0069; A44C  
9/0076; A44C 9/0084; A44C 9/0092;  
A44C 9/02; A44C 17/0258; A44C  
17/0266; A44C 17/0275; A44C 17/0283;  
A44C 17/02; A44C 17/0208; A44C  
17/0216; A44C 17/0225; A44C 17/0233;  
A44C 17/0241; A44C

(Continued)

(56) **References Cited**  
**U.S. PATENT DOCUMENTS**  
1,422,819 A \* 7/1922 Blaicher ..... A44C 9/00  
63/15  
D61,614 S \* 10/1922 Weinberg ..... D11/34  
(Continued)

**OTHER PUBLICATIONS**

[Online] "Carre Band" <https://dumond-jewelry.com/ceremonial-rings/p/ritual-band-xy7dw>. Retrieved Jun. 18, 2022.\*

*Primary Examiner* — Melanie Pellegrini  
(74) *Attorney, Agent, or Firm* — Norton Rose Fulbright  
US LLP

(57) **CLAIM**

The ornamental design for a jewelry band, as shown and described.

**DESCRIPTION**

FIG. 1 is a perspective view of a jewelry band showing a first embodiment of my design;  
FIG. 2 is a front view of the first embodiment;  
FIG. 3 is a right view of the first embodiment;  
FIG. 4 is a top view of the first embodiment;  
FIG. 5 is a cross-section view of the first embodiment along line 5-5 of FIG. 2;  
FIG. 6 is a cross-section view of the first embodiment along line 6-6 of FIG. 3;  
FIG. 7 is a perspective view of a jewelry band showing a second embodiment of my design;  
FIG. 8 is a front view of the second embodiment;  
FIG. 9 is a right view of the second embodiment;  
FIG. 10 is a top view of the second embodiment;  
FIG. 11 is a cross-section view of the second embodiment along line 11-11 of FIG. 8;  
FIG. 12 is a cross-section view of the second embodiment along line 12-12 of FIG. 9;  
FIG. 13 is a perspective view of a jewelry band showing a third embodiment of my design;  
FIG. 14 is a front view of the third embodiment;  
FIG. 15 is a right view of the third embodiment;  
FIG. 16 is a top view of the third embodiment;  
FIG. 17 is a cross-section view of the third embodiment along line 17-17 of FIG. 14; and,  
FIG. 18 is a cross-section view of the third embodiment along line 18-18 of FIG. 15.

The broken lines shown in the figures represent unclaimed subject matter and form no part of the claimed design. The surface is lined for contour only. No claim is made to portions not shown in the drawings.

**1 Claim, 9 Drawing Sheets**

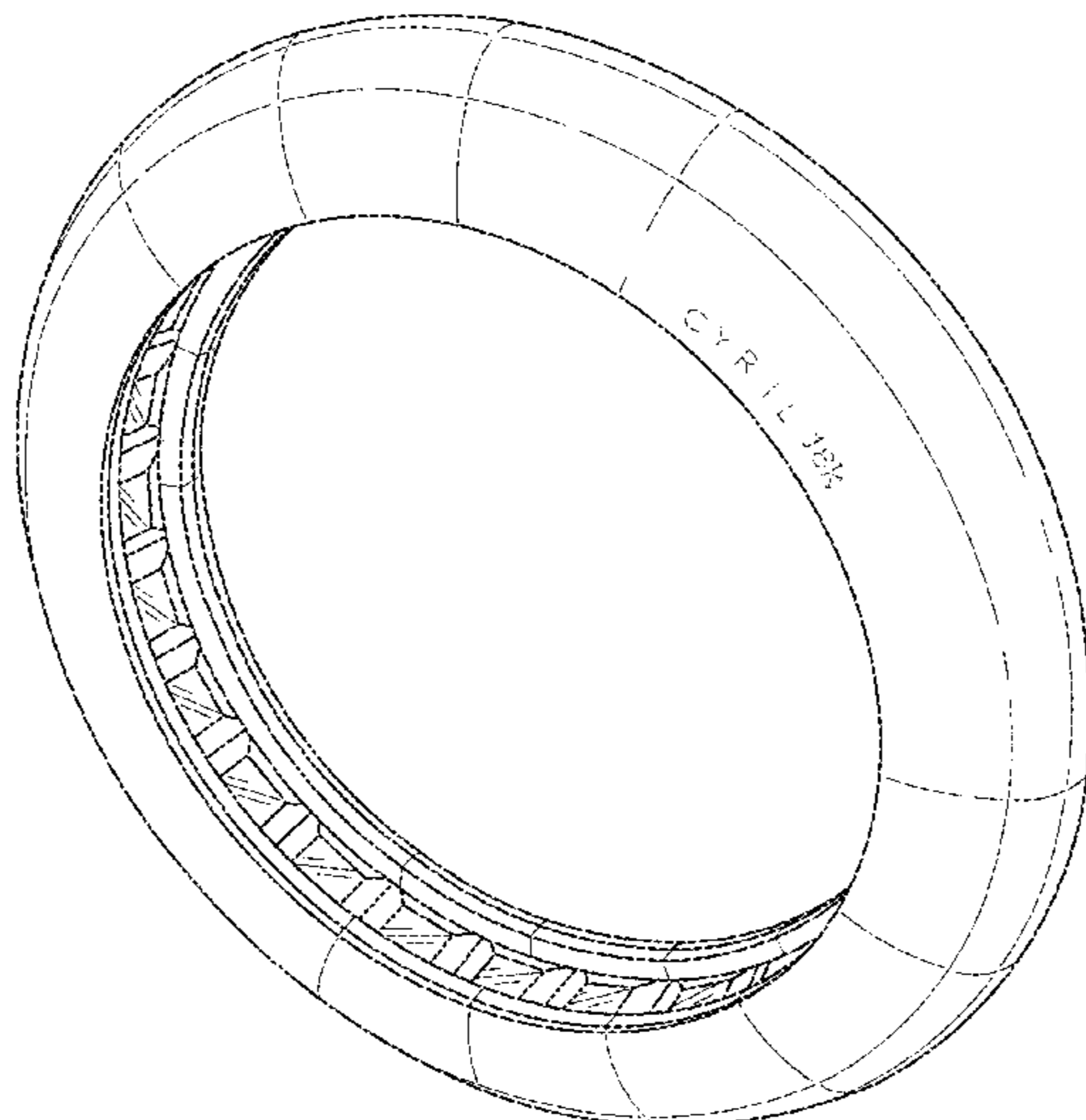

(58) **Field of Classification Search**

CPC ..... 17/025; A44C 17/0288; A44C 17/0291;  
A44C 1/00; A44C 15/00; A44C 15/0005;  
A44C 15/001; A44C 15/005

See application file for complete search history.

(56) **References Cited**

U.S. PATENT DOCUMENTS

D329,992	S *	10/1992	Dostourian	.....	D11/34
D451,046	S *	11/2001	Itzkowitz	.....	D11/26
D589,839	S *	4/2009	Dostourian	.....	D11/34
D780,018	S *	2/2017	Rivière	.....	D11/34
D951,801	S *	5/2022	DeVolder	.....	D11/34
2007/0044509	A1 *	3/2007	Grad	.....	A44C 9/00 63/28
2009/0071192	A1 *	3/2009	Bauman	.....	A44C 17/046 63/26
2017/0049195	A1 *	2/2017	Dholakiya	.....	A44C 17/04
2018/0168298	A1 *	6/2018	Bassan	.....	A44C 17/02

\* cited by examiner

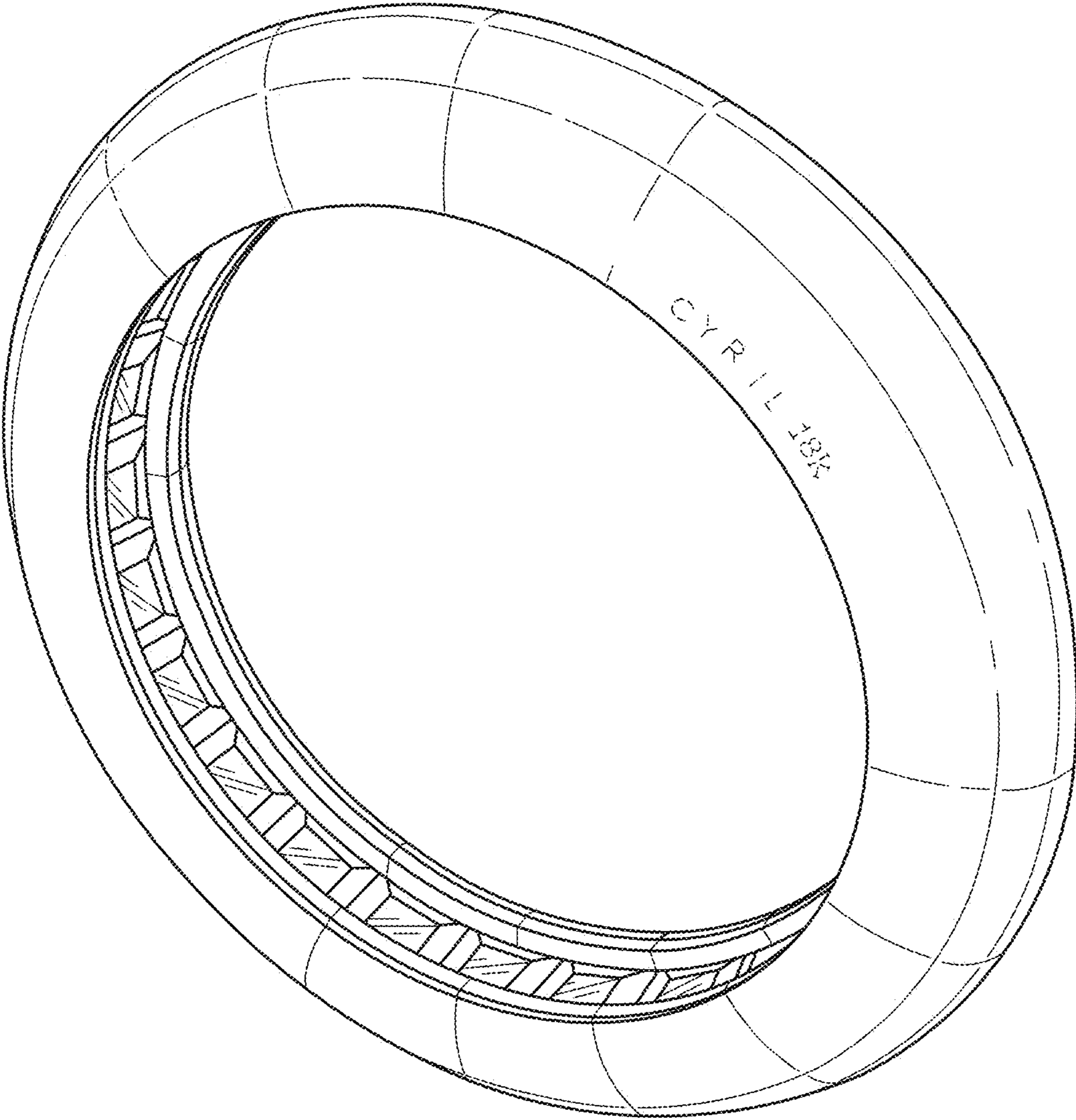

FIG. 1

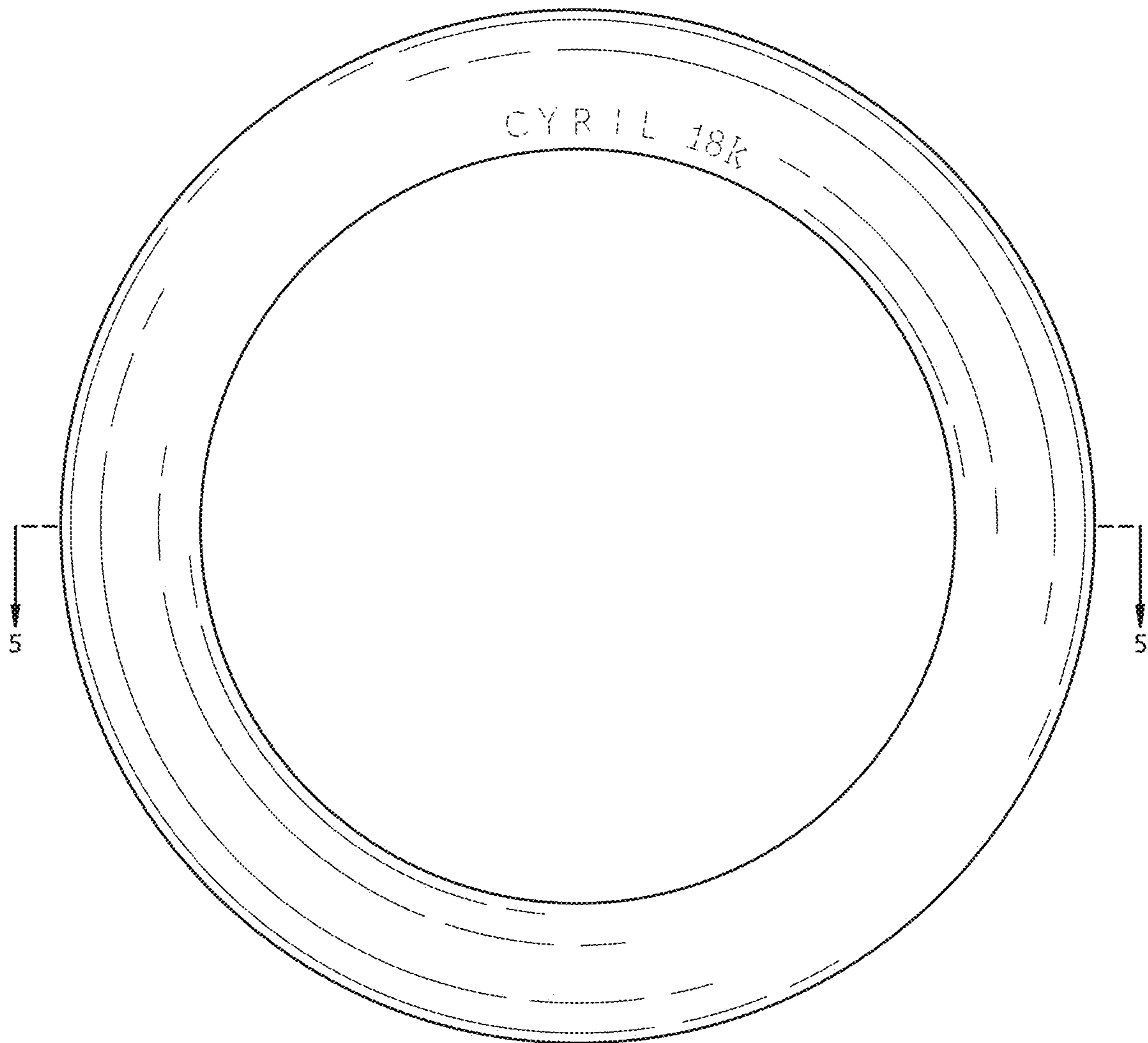

FIG. 2

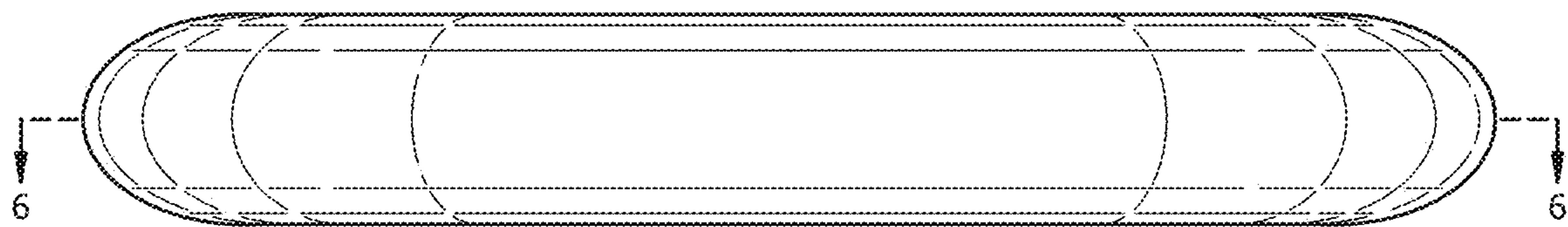

FIG. 3

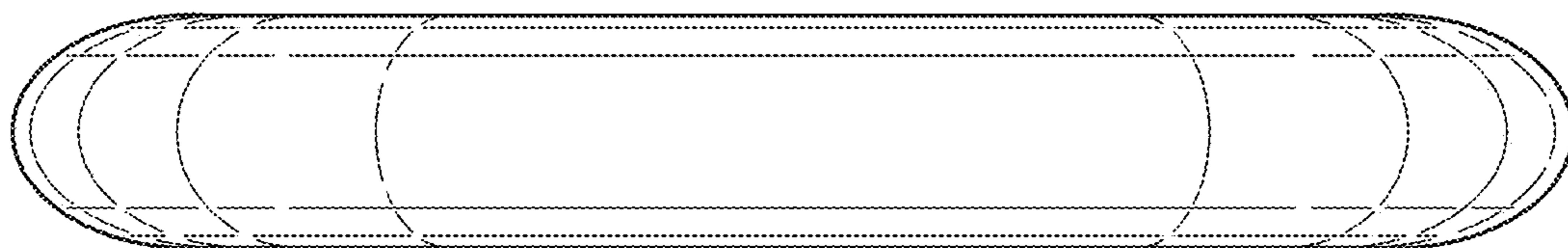

FIG. 4

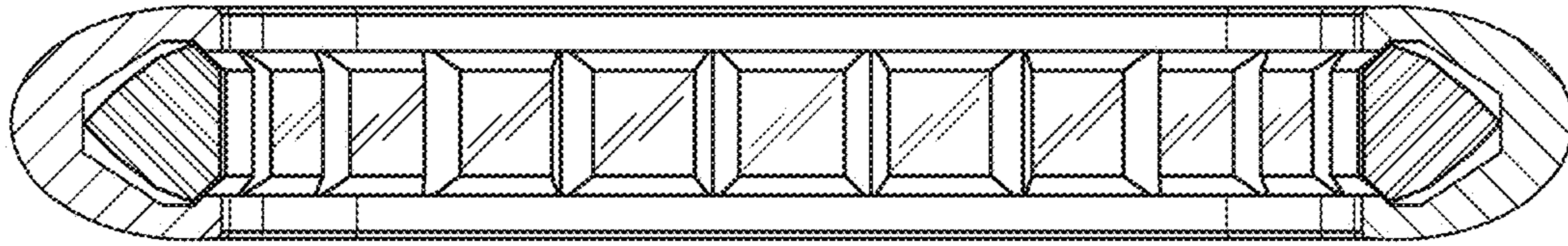

FIG. 5

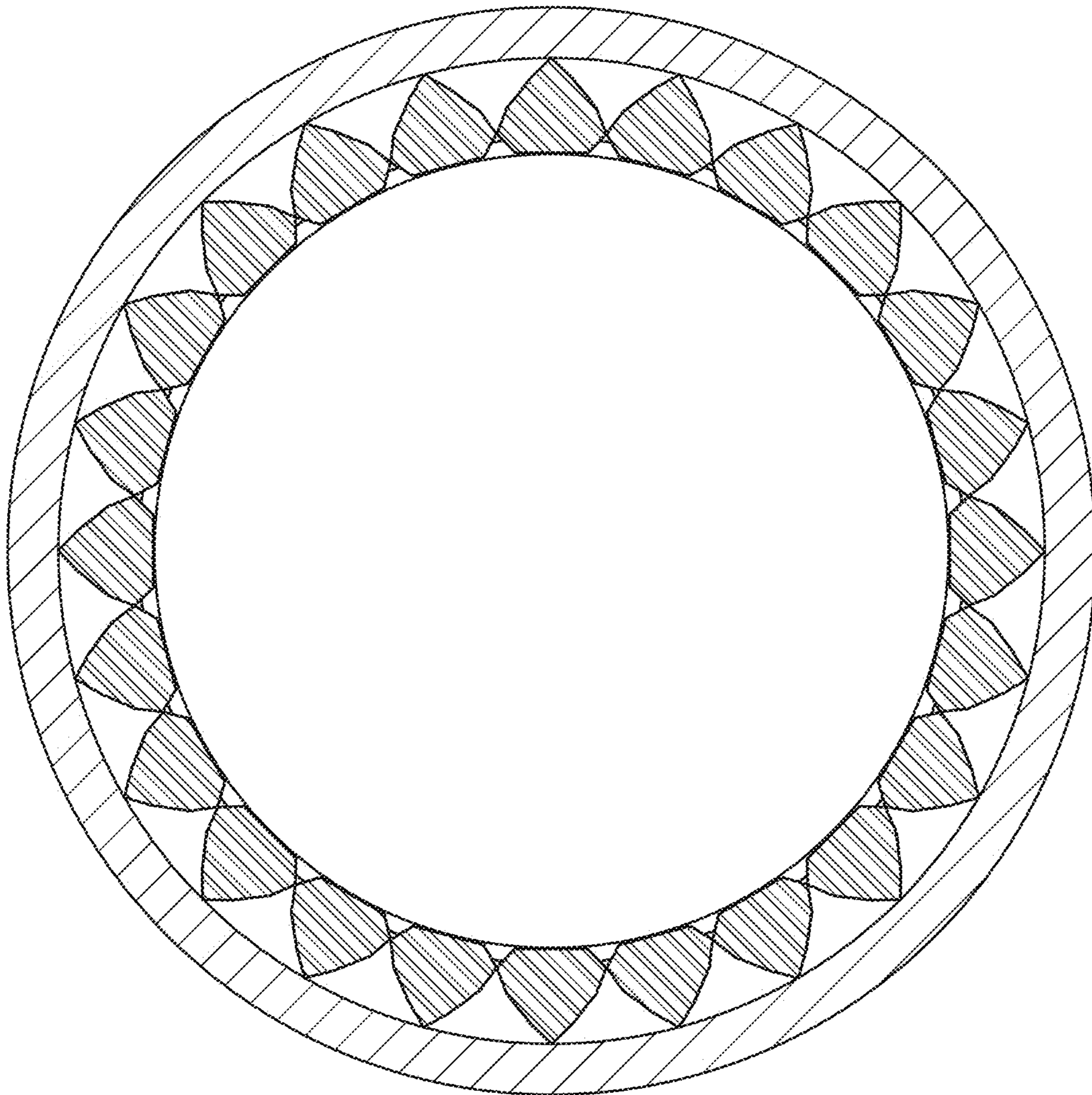

FIG. 6

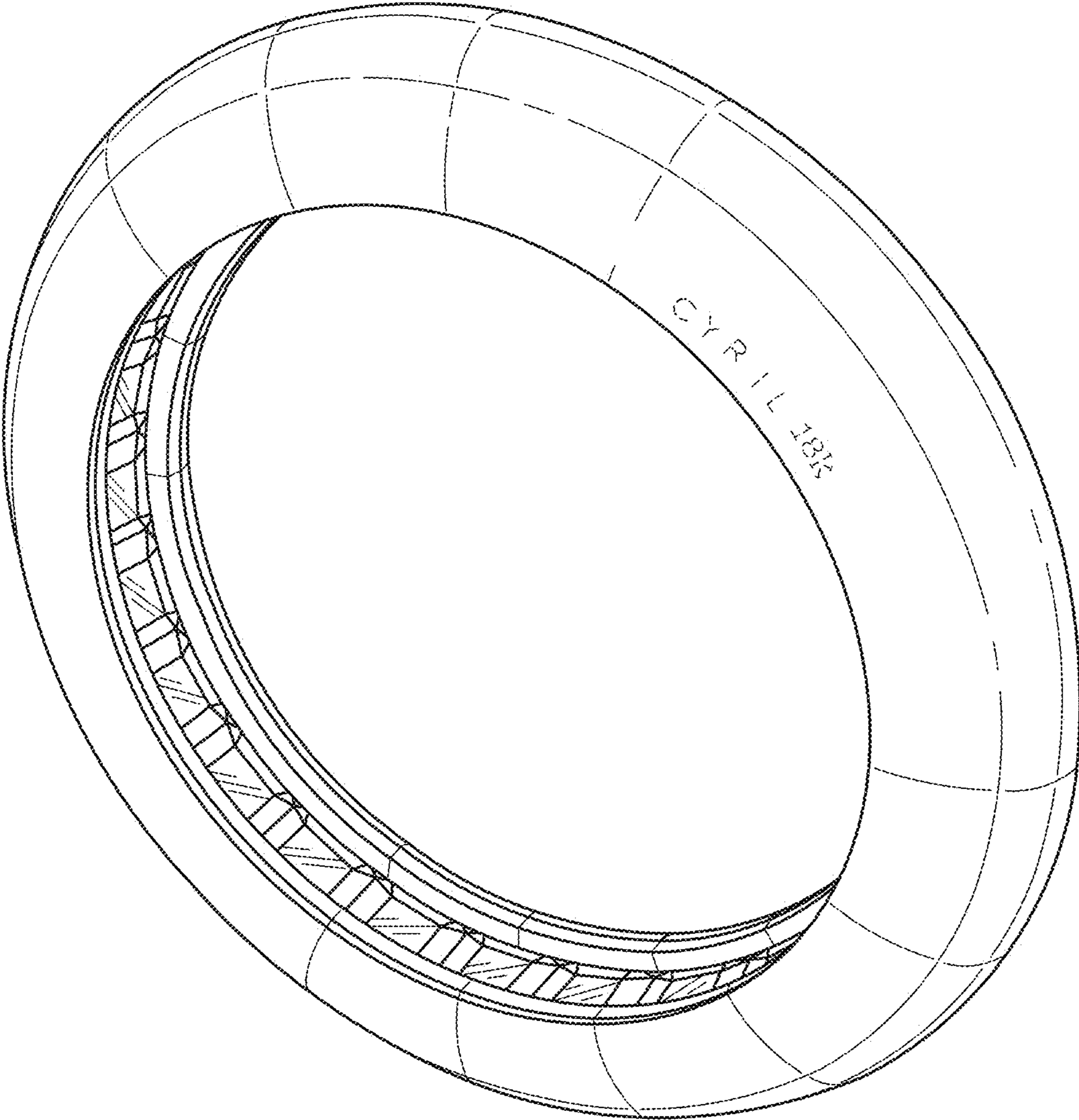

FIG. 7

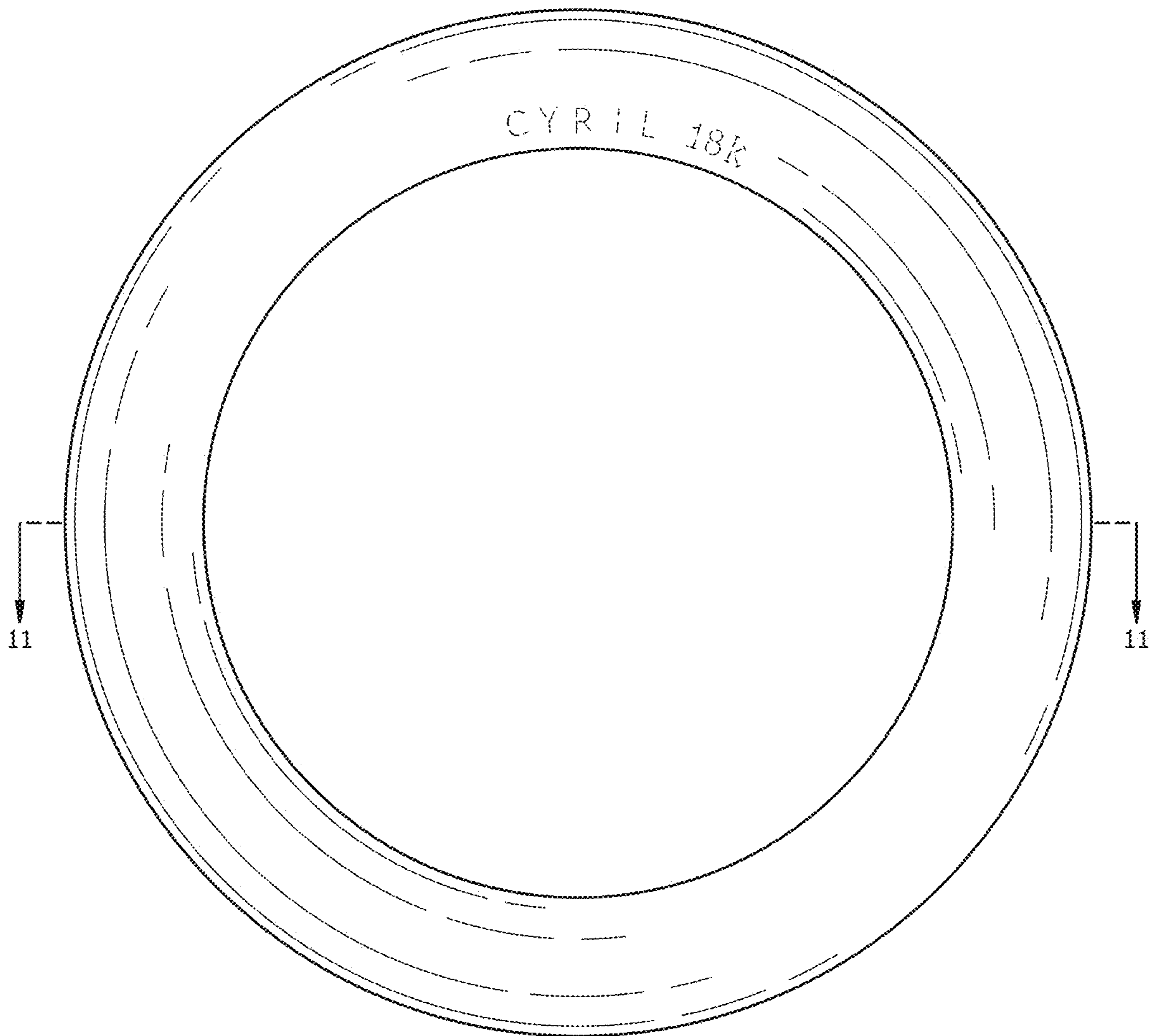

FIG. 8

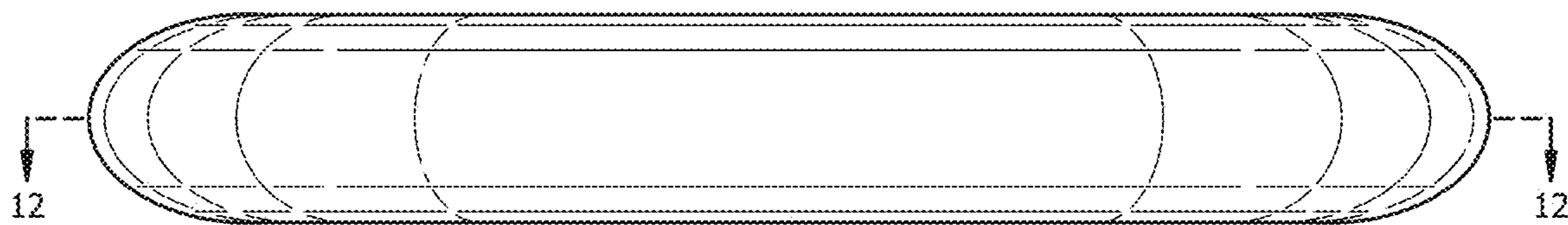

FIG. 9

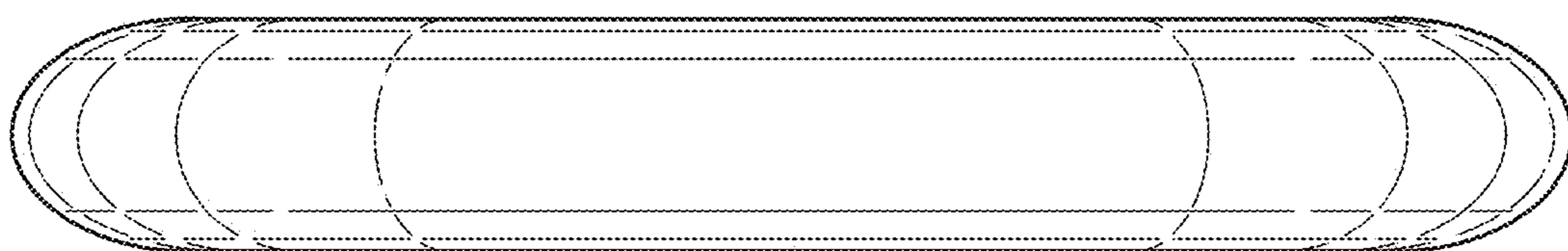

FIG. 10

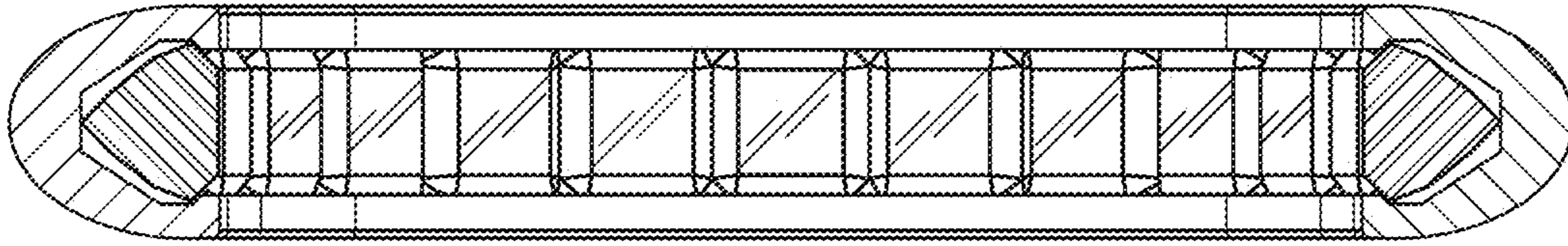

FIG. 11

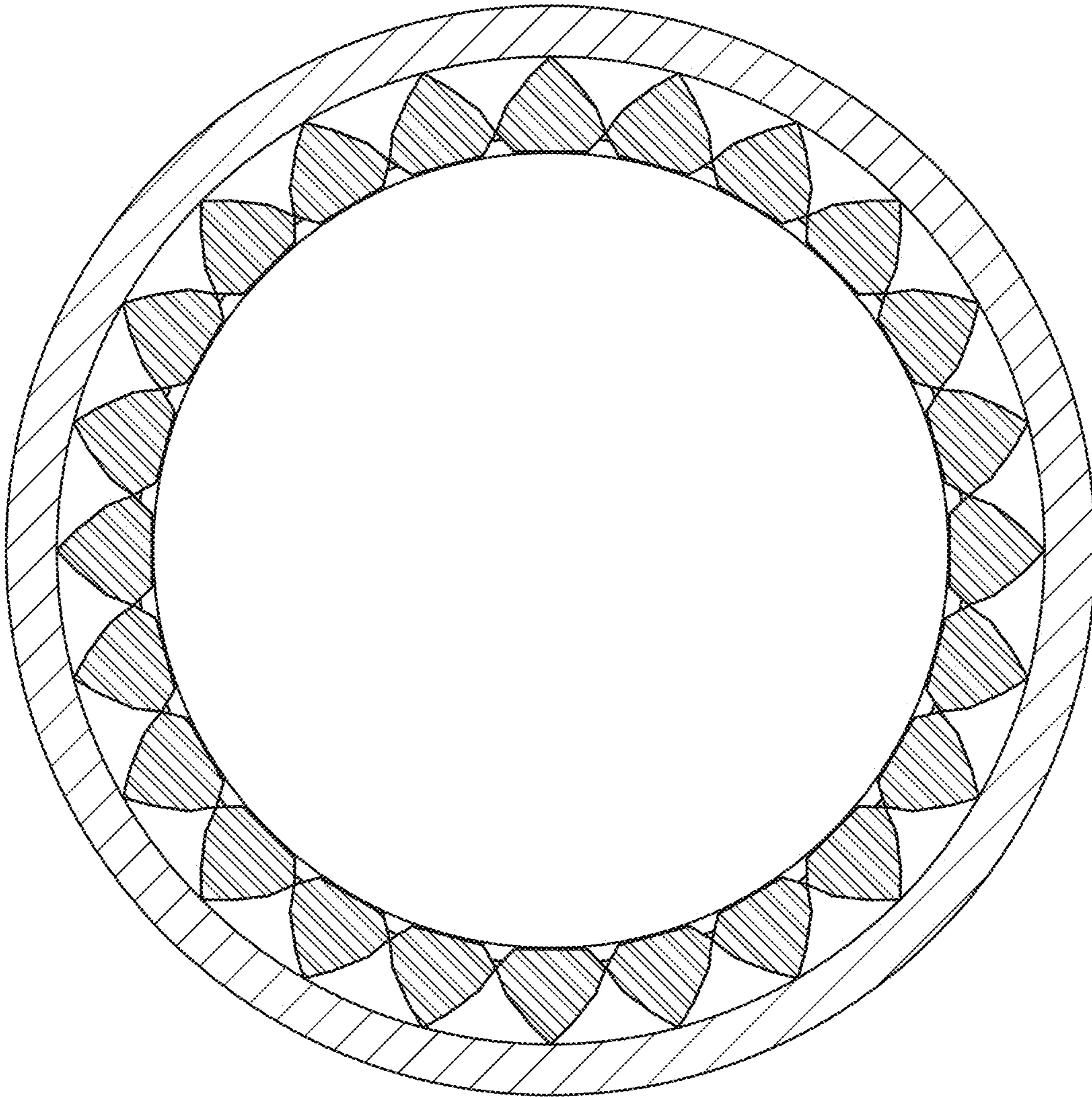

FIG. 12



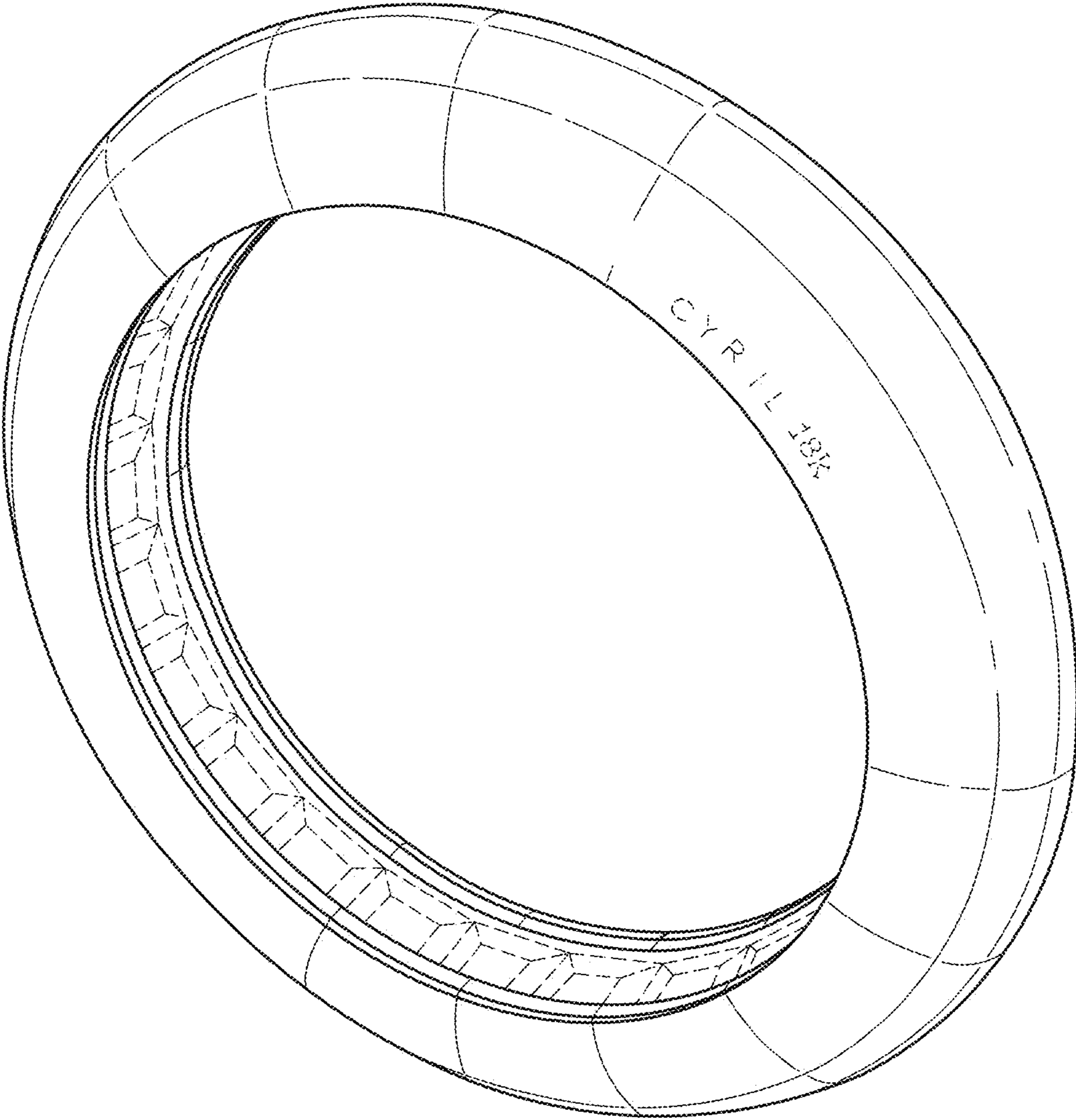

FIG. 13

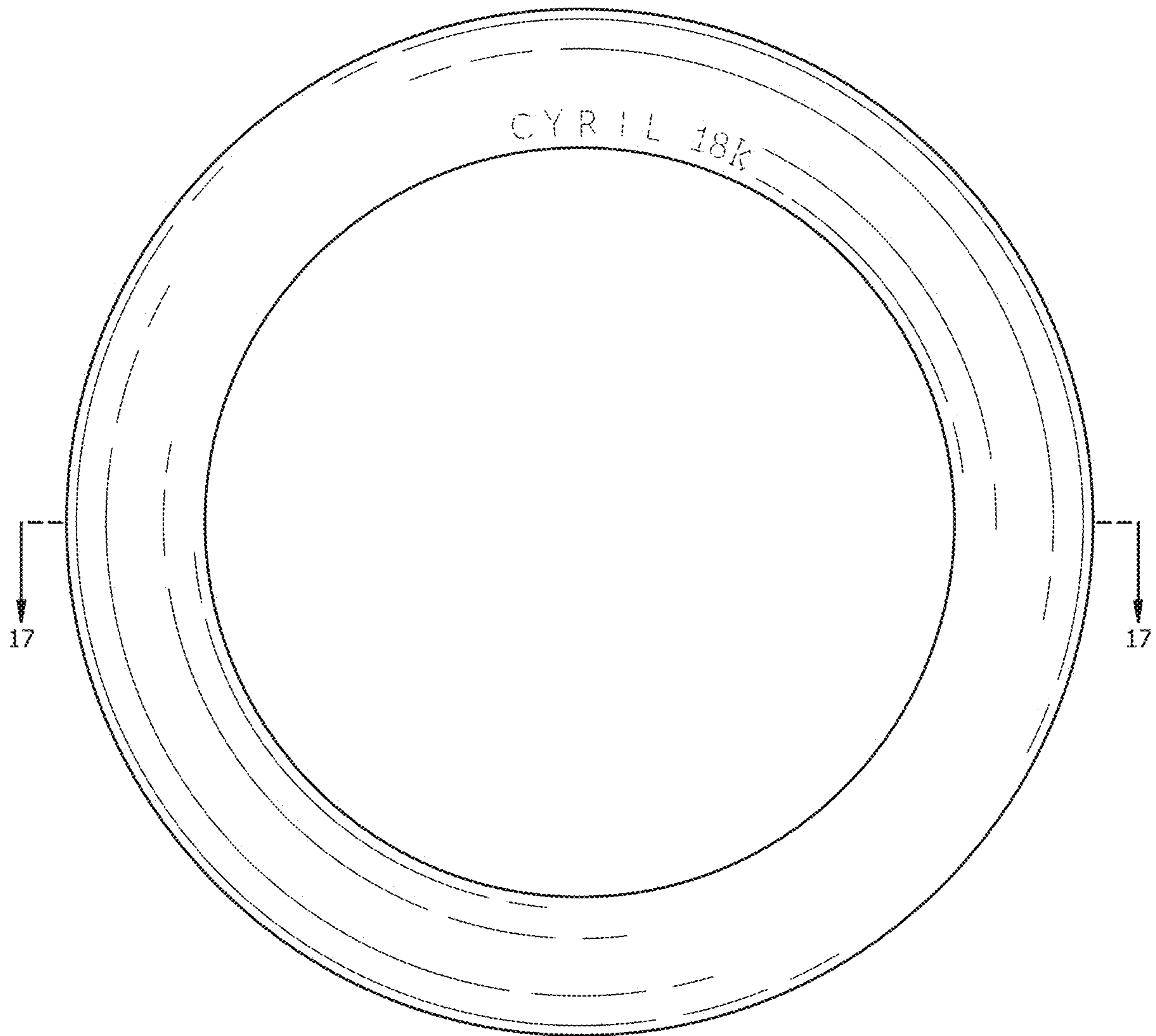

FIG. 14

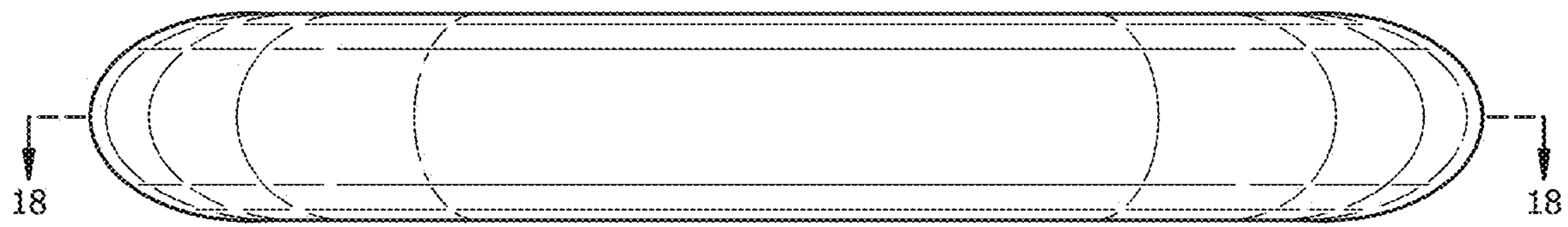

FIG. 15

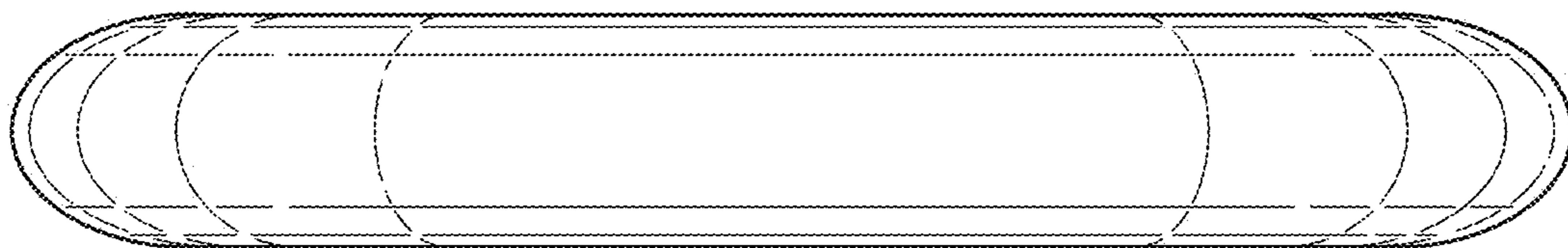

FIG. 16

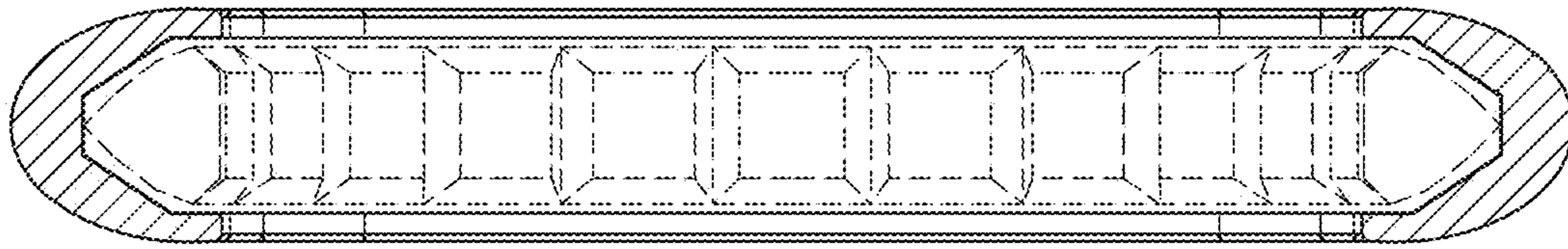

FIG. 17

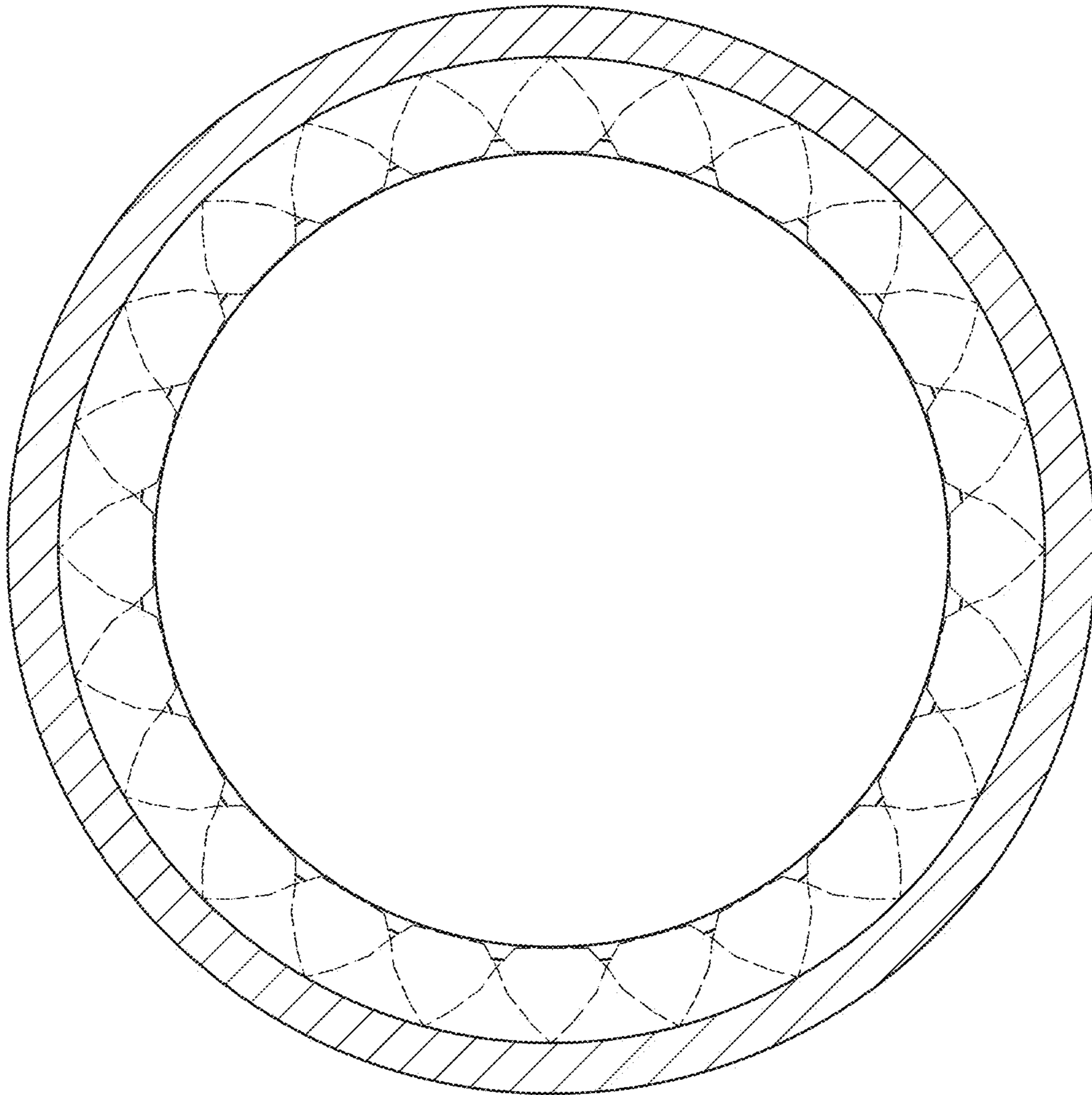

FIG. 18