



US00D971965S

(12) **United States Design Patent**
Murugesan et al.

(10) **Patent No.:** **US D971,965 S**
(45) **Date of Patent:** **** Dec. 6, 2022**

(54) **INTAKE MANIFOLD SECTION**

(71) Applicant: **Powerhouse Engine Solutions**
Switzerland IP Holding GmbH, Zug
(CH)

(72) Inventors: **Ganesasubramanian Murugesan,**
Bangalore (IN); **Michael Mendoza,**
Fredonia, PA (US)

(73) Assignee: **Powerhouse Engine Solutions**
Switzerland IP Holding GmbH, Zug
(CH)

(**) Term: **15 Years**

(21) Appl. No.: **29/739,587**

(22) Filed: **Jun. 26, 2020**

(51) **LOC (13) Cl.** **15-01**

(52) **U.S. Cl.**
USPC **D15/5**

(58) **Field of Classification Search**
USPC D15/1, 2, 3, 4, 5
(Continued)

(56) **References Cited**

U.S. PATENT DOCUMENTS

3,433,206 A * 3/1969 Pennington F01P 11/12
123/41.7
D555,775 S * 11/2007 Bonde D23/364
(Continued)

OTHER PUBLICATIONS

CN306579997 Patent Date Jun. 1, 2021 Transportation intellectual
property Holding Co Ltd, Connecticut, USA, (US) (Year: 2021).*
(Continued)

Primary Examiner — Ania Aman

(74) *Attorney, Agent, or Firm* — McCoy Russell LLP

(57) **CLAIM**

The ornamental design for an intake manifold section, as shown and described.

DESCRIPTION

FIG. 1 is a rear-top-left perspective view of an intake manifold section, according to a first embodiment of the present invention.

FIG. 2 is a left side view of the intake manifold section of FIG. 1.

FIG. 3 is a right side view of the intake manifold section of FIG. 1.

FIG. 4 is a rear view of the intake manifold section of FIG. 1.

FIG. 5 is a front view of the intake manifold section of FIG. 1.

FIG. 6 is a top view of the intake manifold section of FIG. 1.

FIG. 7 is a bottom view of the intake manifold section of FIG. 1.

FIG. 8 is a rear-top-left perspective view of an intake manifold section, according to a second embodiment of the present invention.

FIG. 9 is a left side view of the intake manifold section of FIG. 8.

FIG. 10 is a right side view of the intake manifold section of FIG. 8.

FIG. 11 is a rear view of the intake manifold section of FIG. 8.

FIG. 12 is a front view of the intake manifold section of FIG. 8.

FIG. 13 is a top view of the intake manifold section of FIG. 8; and,

FIG. 14 is a bottom view of the intake manifold section of FIG. 8.

The dash-dash broken lines in the drawings illustrate portions of the intake manifold section that form no part of the claimed design.

The depth of the portions of the intake manifold section enclosed by dash-dot-dot broken lines in FIGS. 6 and 13 of the drawings forms no part of the claimed design.

1 Claim, 14 Drawing Sheets

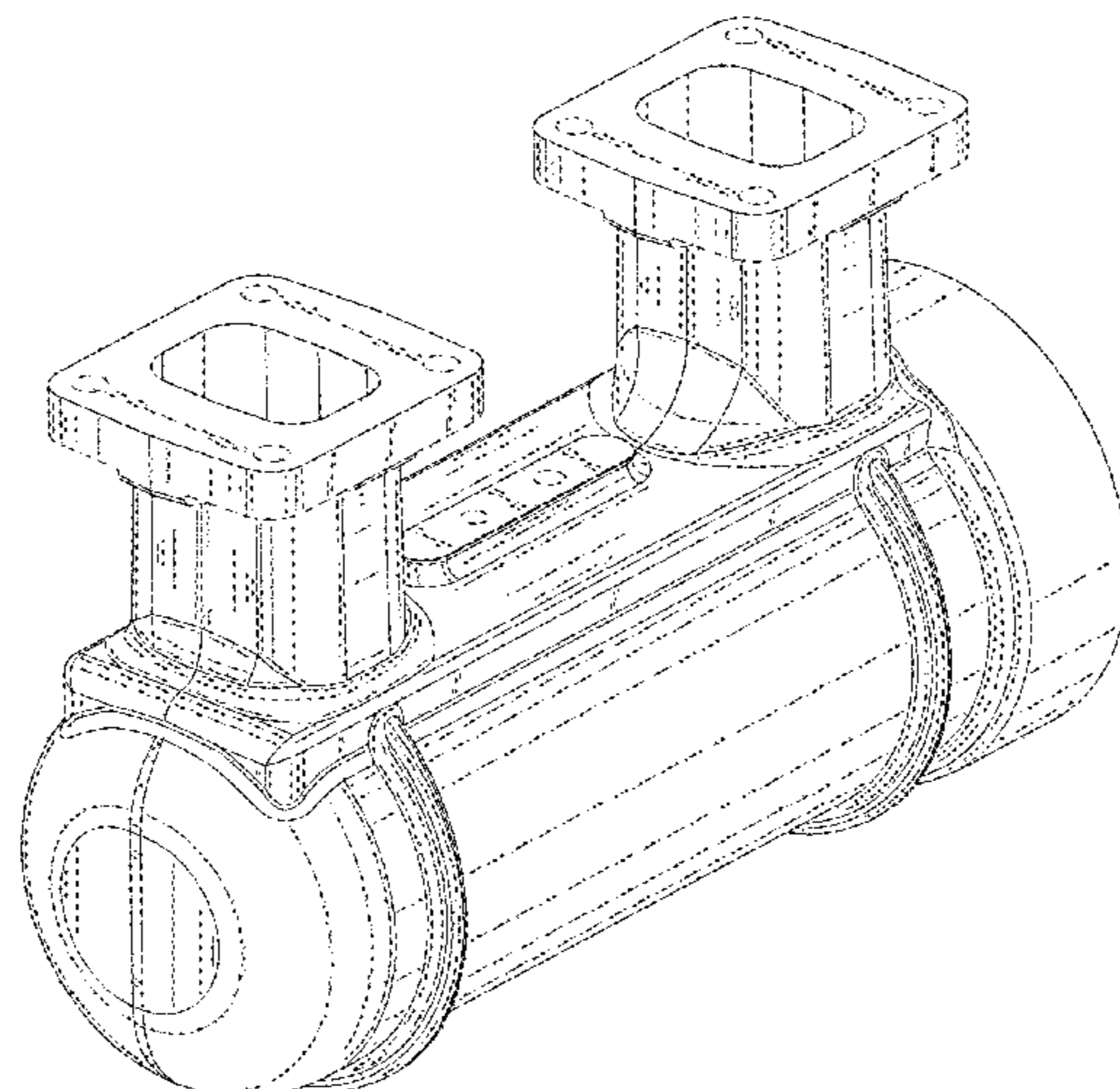

- (58) **Field of Classification Search**
 CPC B60K 13/02; F02M 35/10013; F02M
 35/10026; F02M 35/10078; F02M
 35/10091; F02M 26/31; F02M 35/116;
 F02M 35/112; F02M 35/1042; F02M
 35/1045; F02M 35/104; F02B 29/045;
 F02B 29/0481

See application file for complete search history.

(56) **References Cited**

U.S. PATENT DOCUMENTS

D590,419	S *	4/2009	Duffek	D15/5
D707,258	S *	6/2014	Tomioka	D15/5
D717,343	S *	11/2014	Chino	D15/5
D718,337	S *	11/2014	Mitsuda	D15/5
8,893,481	B2 *	11/2014	Katou	F01N 3/10 60/295
8,991,160	B2 *	3/2015	Katou	F01N 3/2066 60/295
D733,187	S *	6/2015	Bink	D15/5
9,062,589	B2 *	6/2015	Katou	F01N 3/2066
D733,762	S *	7/2015	Bink	D15/1
D786,308	S *	5/2017	Nagao	D15/1
2006/0086549	A1 *	4/2006	Smith	F02M 35/024 180/68.3
2007/0199321	A1 *	8/2007	Miura	F02B 29/0462 60/599
2010/0050865	A1 *	3/2010	Johnson	F02M 35/10321 95/17
2011/0000199	A1 *	1/2011	Ezawa	E02F 9/0866 60/311
2011/0120085	A1 *	5/2011	Saito	F01N 13/1827 60/272

2011/0192671	A1 *	8/2011	Mitsuda	B60K 13/04 180/309
2014/0261259	A1 *	9/2014	Sullivan	F02F 7/007 123/41.65
2017/0218832	A1 *	8/2017	Kurokawa	F01P 11/0295
2019/0366835	A1 *	12/2019	Wingate	B60K 13/04

OTHER PUBLICATIONS

RU00125658 Patent Date May 31, 2021 Transport IP Holdings LLS (Year: 2021).*

RU00125522 Patent Date May 23, 2021 Transport IP Holdings LLS (Year: 2021).*

EU008342760-002 Patent Date Jan. 12, 2021 Powerhouse Engine Solutions Switzerland IP Holding GmbH, c/o Centralis Switzerland GmbH Bahnhofstrasse 10, Zürich Connecticut 6300, Estados Unidos (De América) (Year: 2021).*

EU008342760-001 Patent Date Jan. 12, 2021 Powerhouse Engine Solutions Switzerland IP Holding GmbH, c/o Centralis Switzerland GmbH Bahnhofstrasse 10, Zürich Connecticut 6300, Estados Unidos (De América) (Year: 2021).*

EU008338016-0002 Patent Date Jan. 12, 2021 Powerhouse Engine Solutions Switzerland IP Holding GmbH, c/o Centralis Switzerland GmbH Bahnhofstrasse 10, Zürich Connecticut 6300, Estados Unidos (De América) (Year: 2021).*

EU008338016-0001 Patent Date Jan. 12, 2021 Powerhouse Engine Solutions Switzerland IP Holding GmbH, c/o Centralis Switzerland GmbH Bahnhofstrasse 10, Zürich Connecticut 6300, Estados Unidos (De América) (Year: 2021).*

Murugesan, G. et al., "An Ornamental Design for an Intake Manifold Section," U.S. Appl. No. 29/739,591, filed Jun. 26, 2020, 15 pages.

* cited by examiner

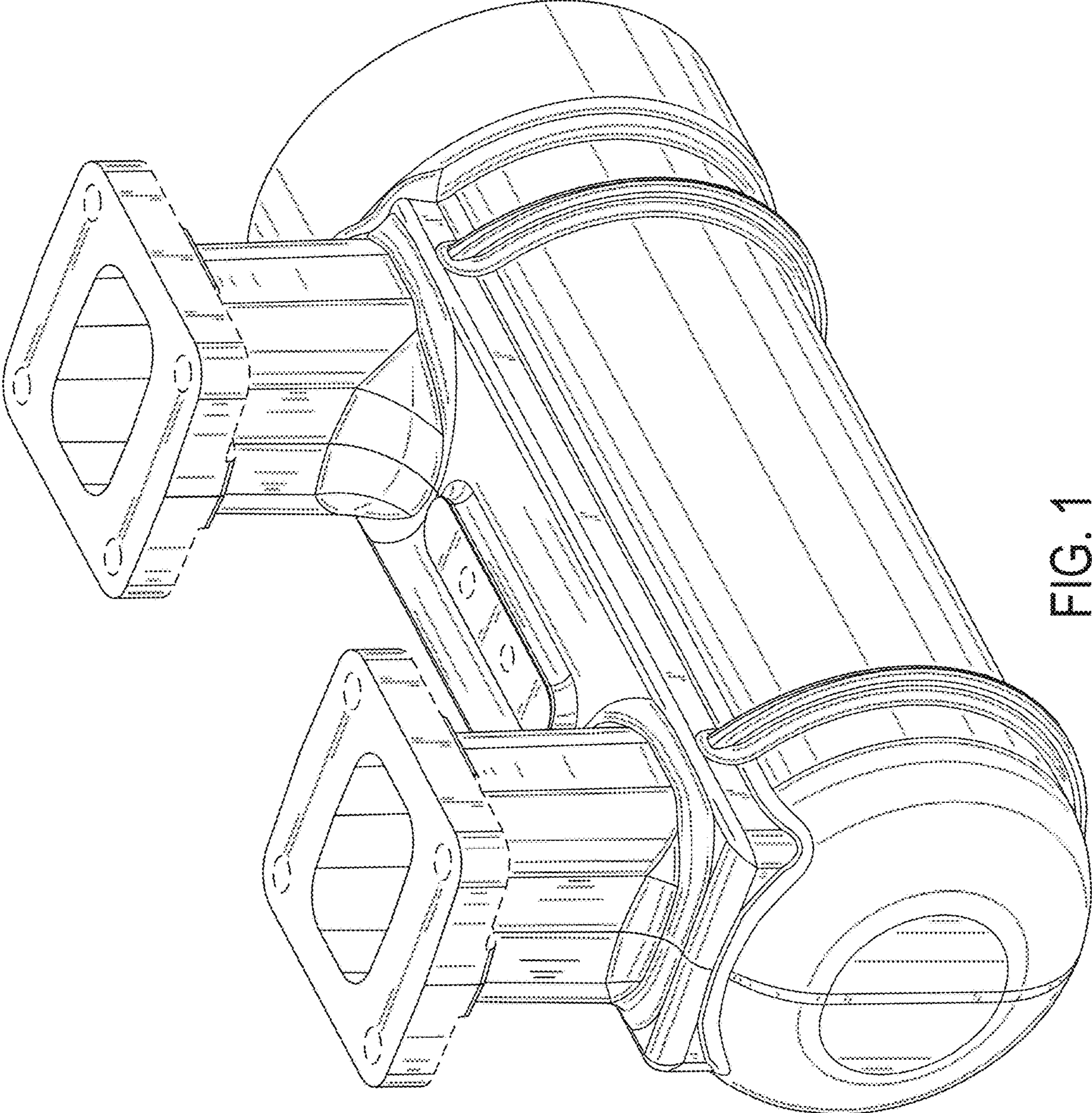

FIG. 1

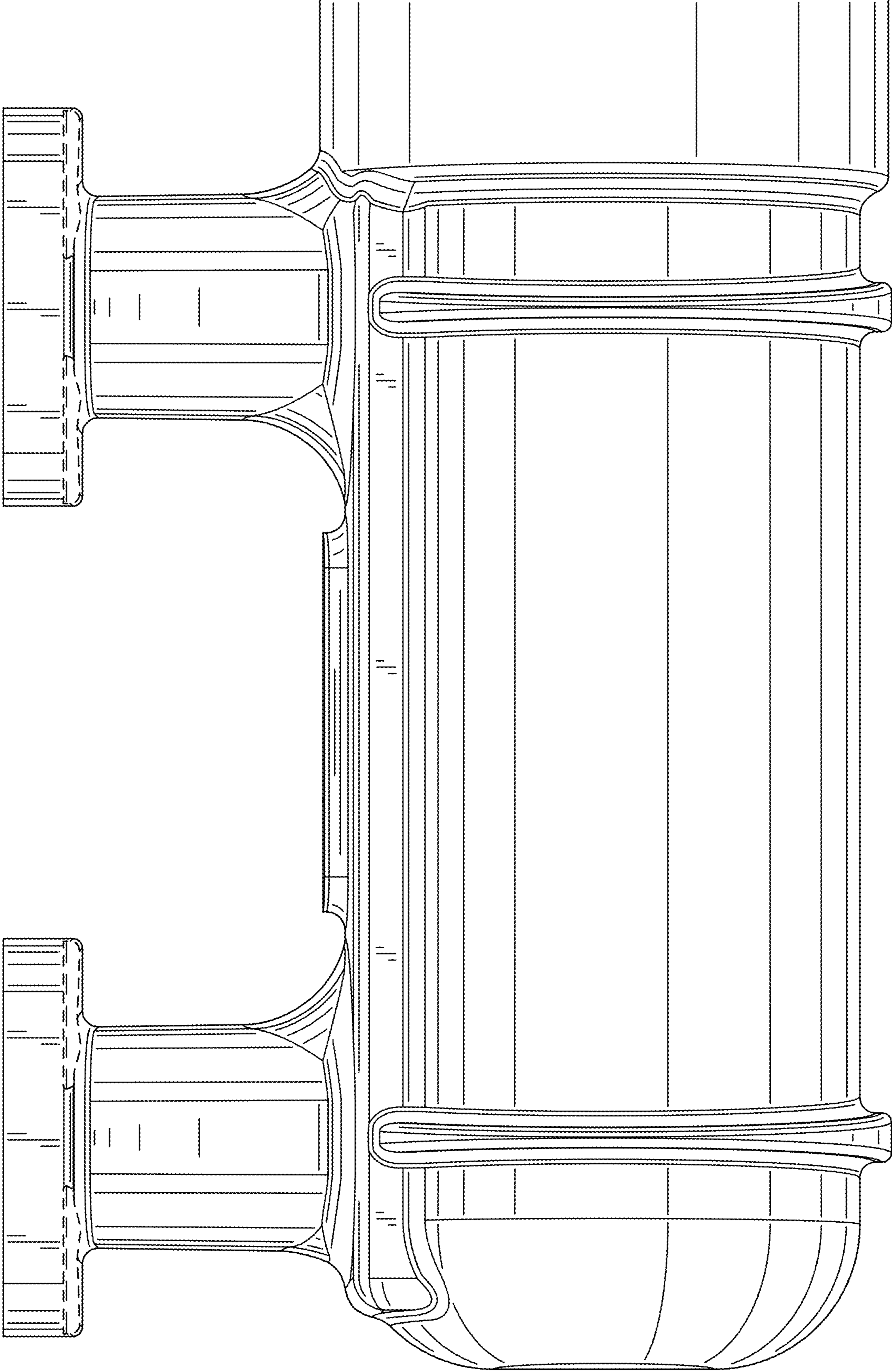

FIG. 2

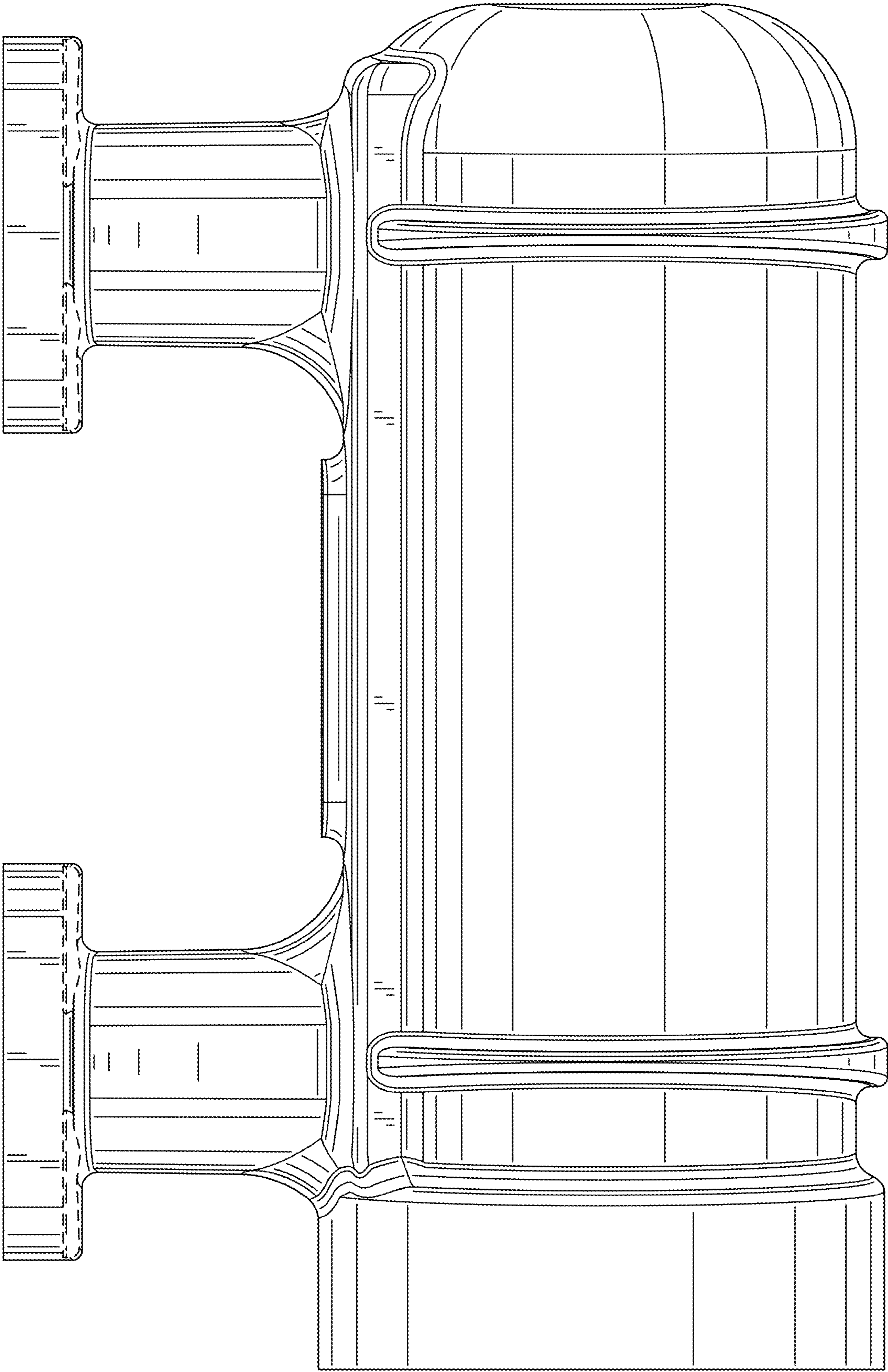

FIG. 3

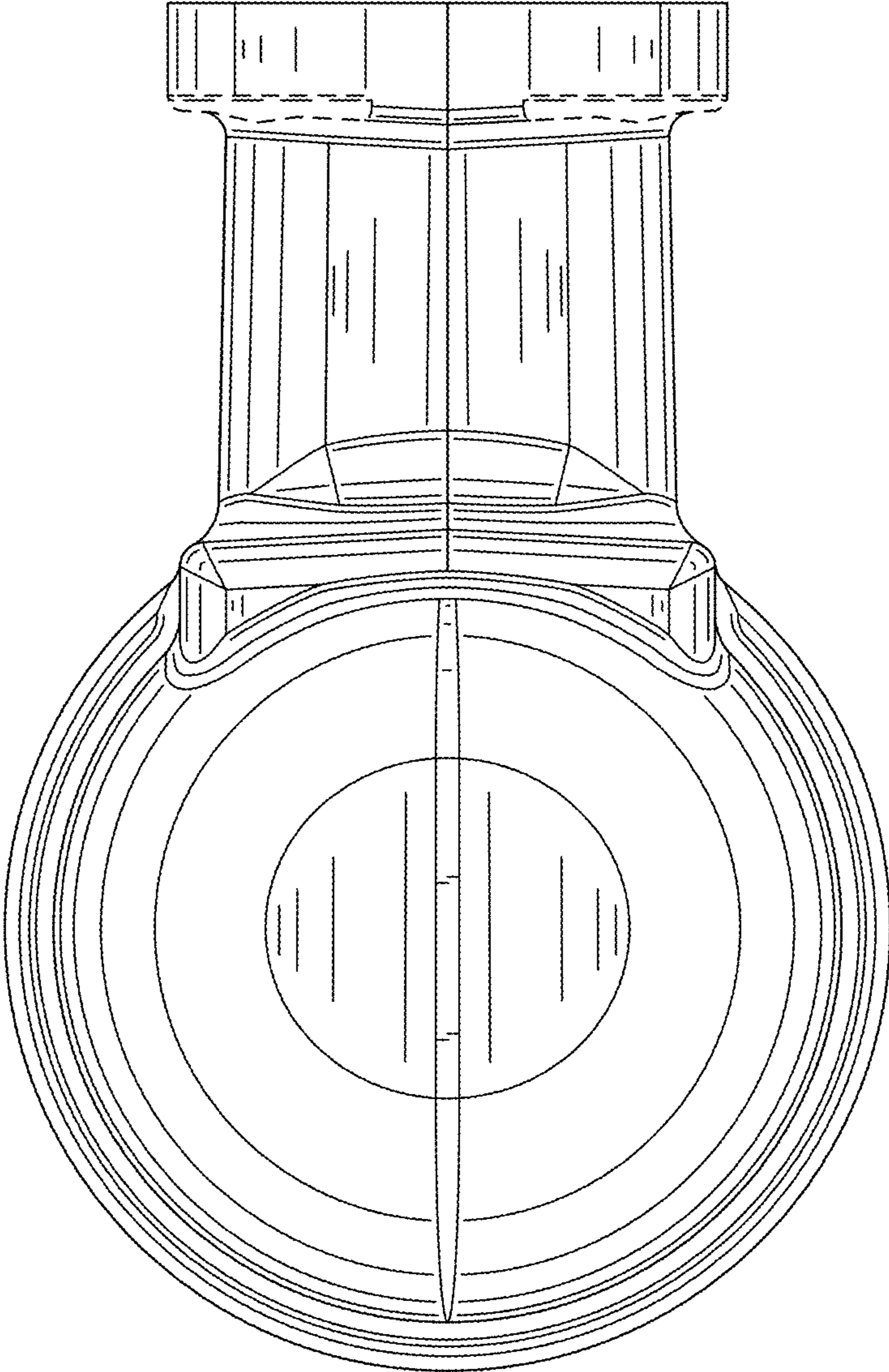

FIG. 4

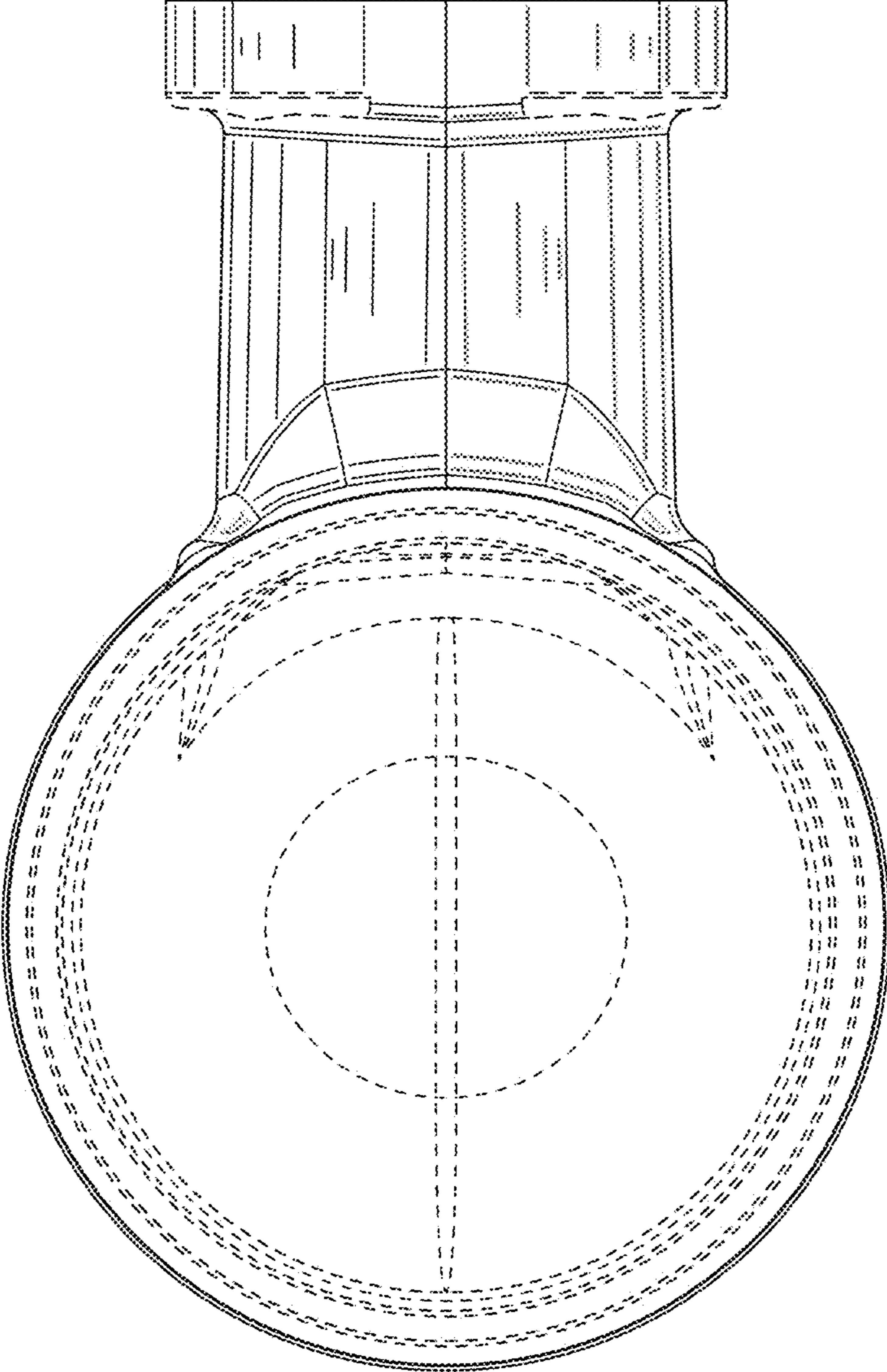

FIG. 5

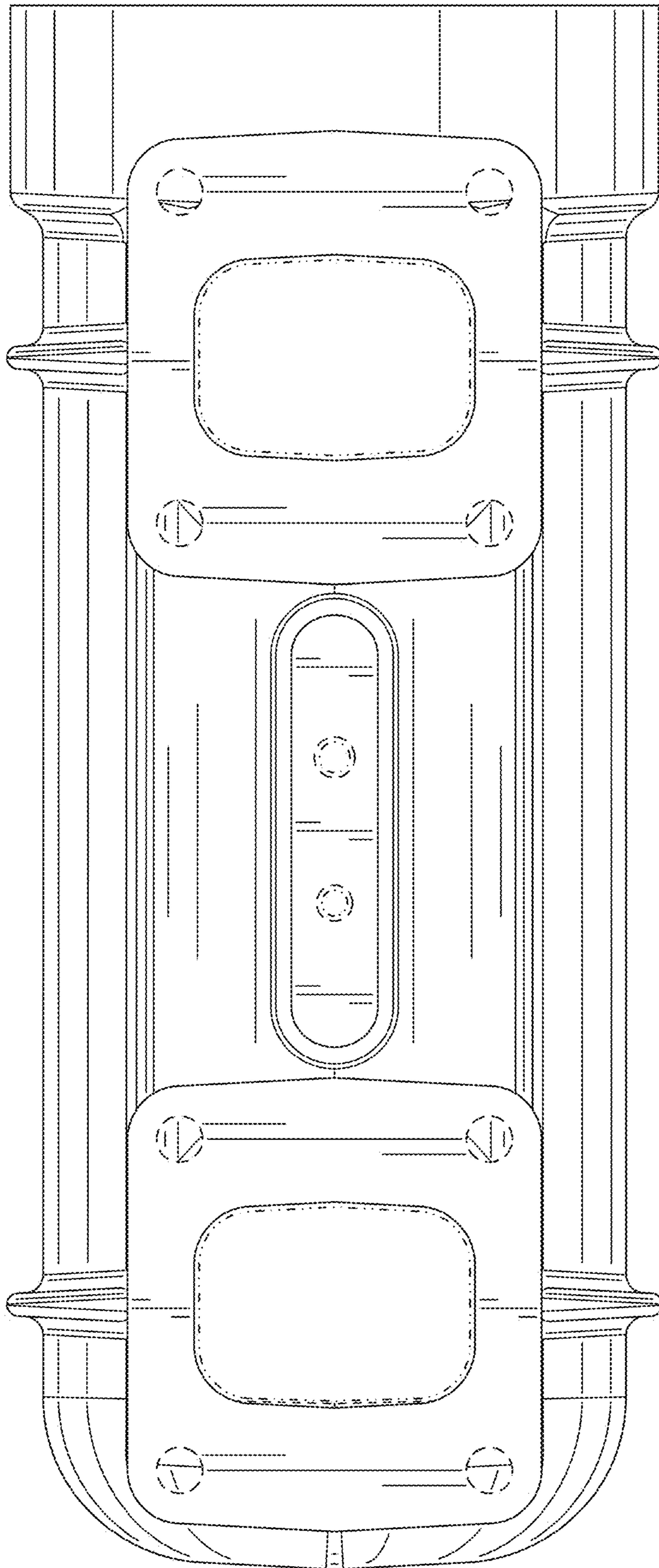

FIG. 6

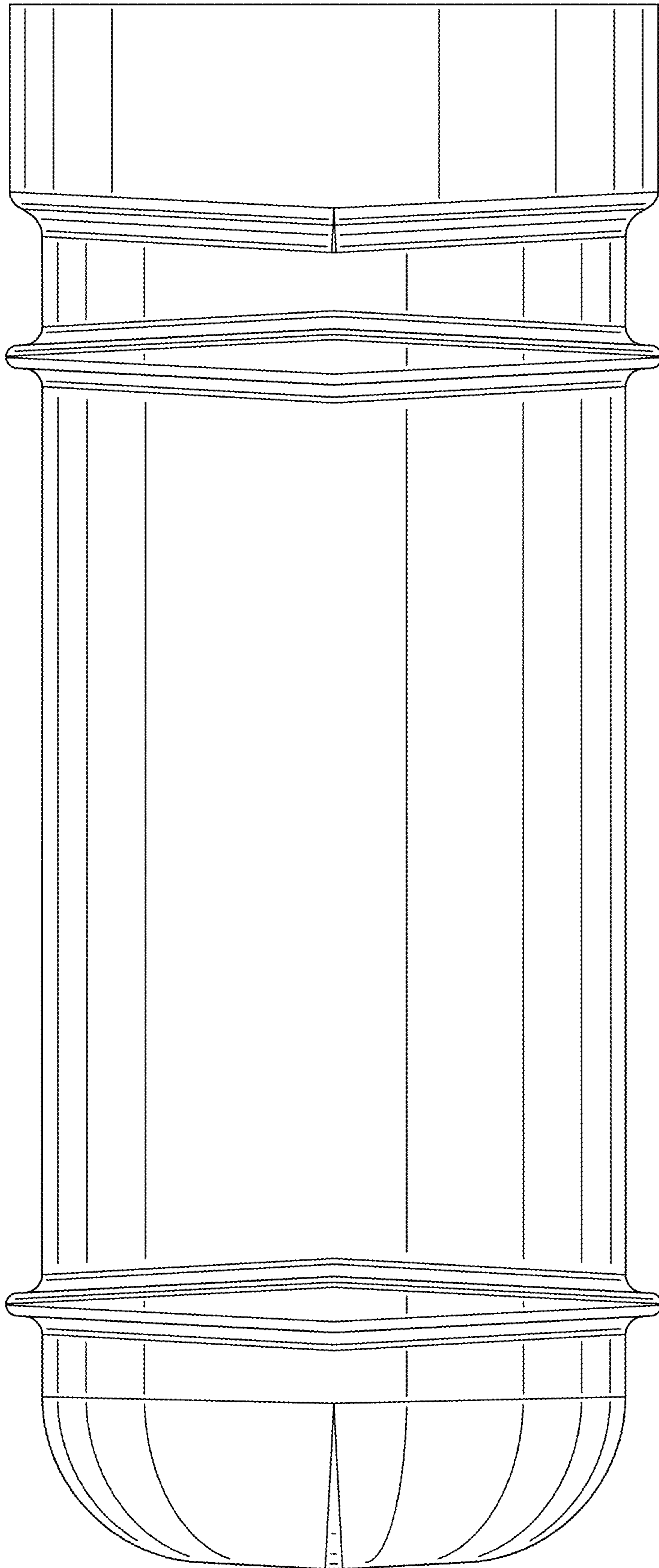

FIG. 7

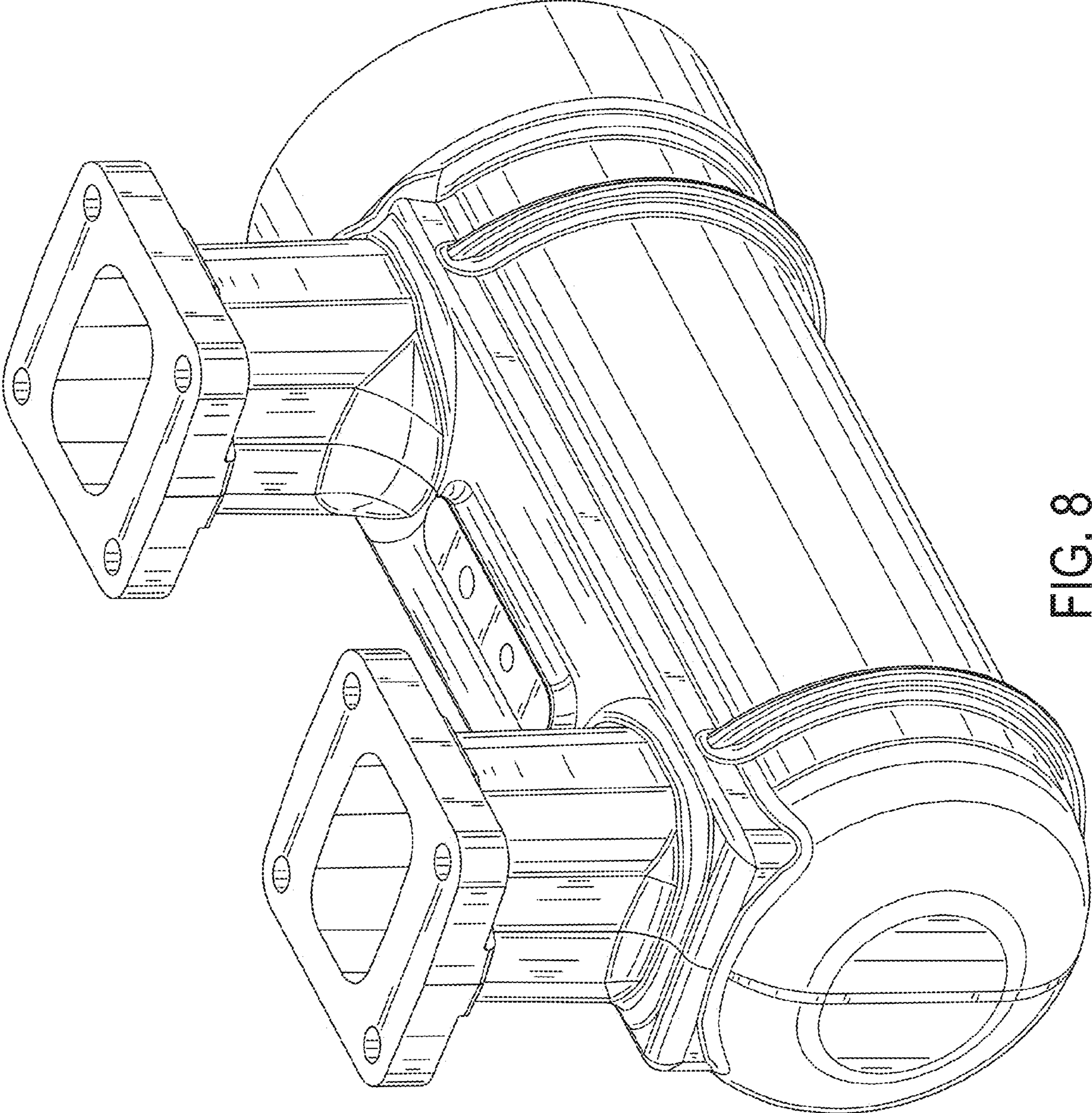

FIG. 8

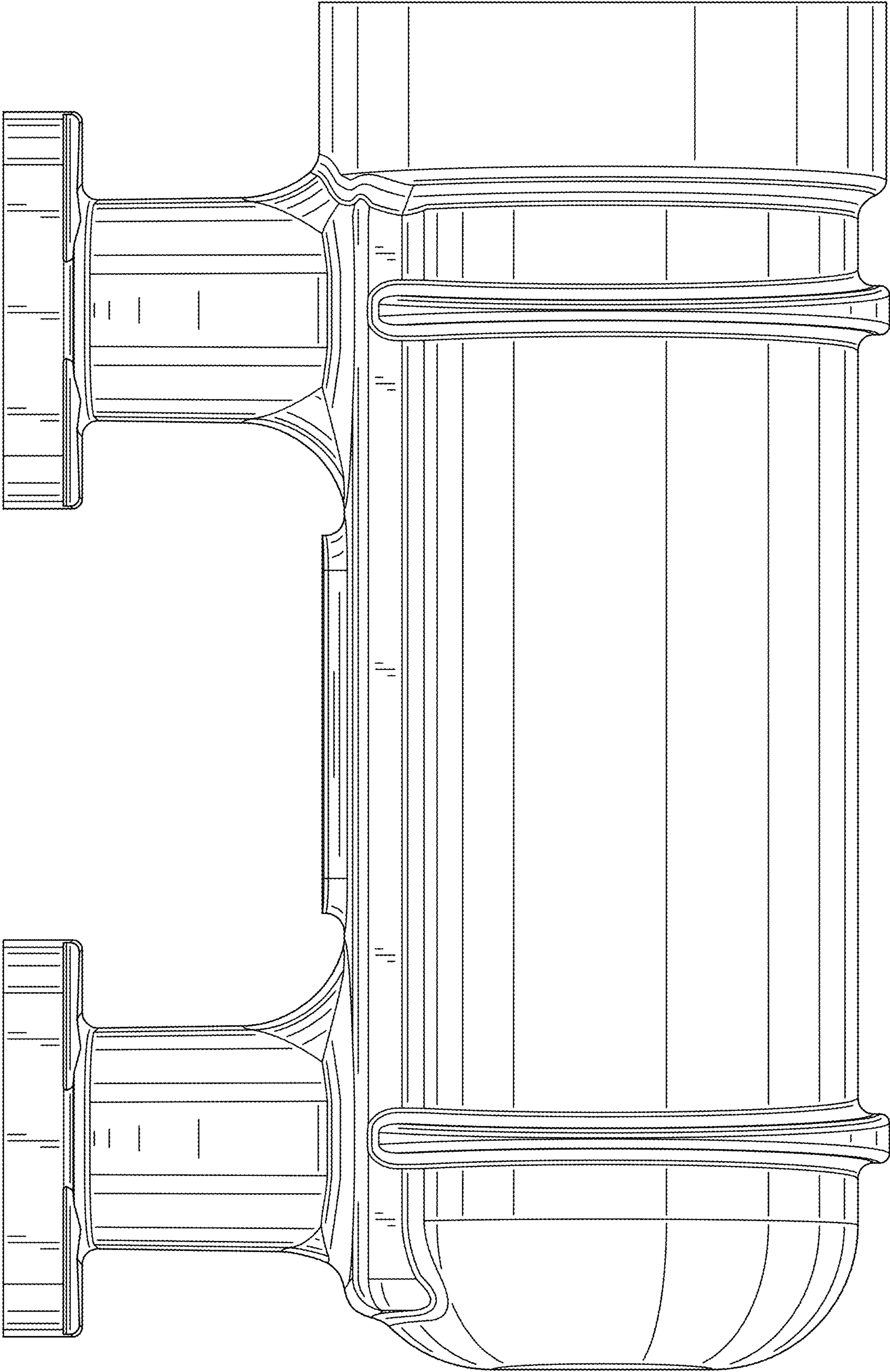

FIG. 9

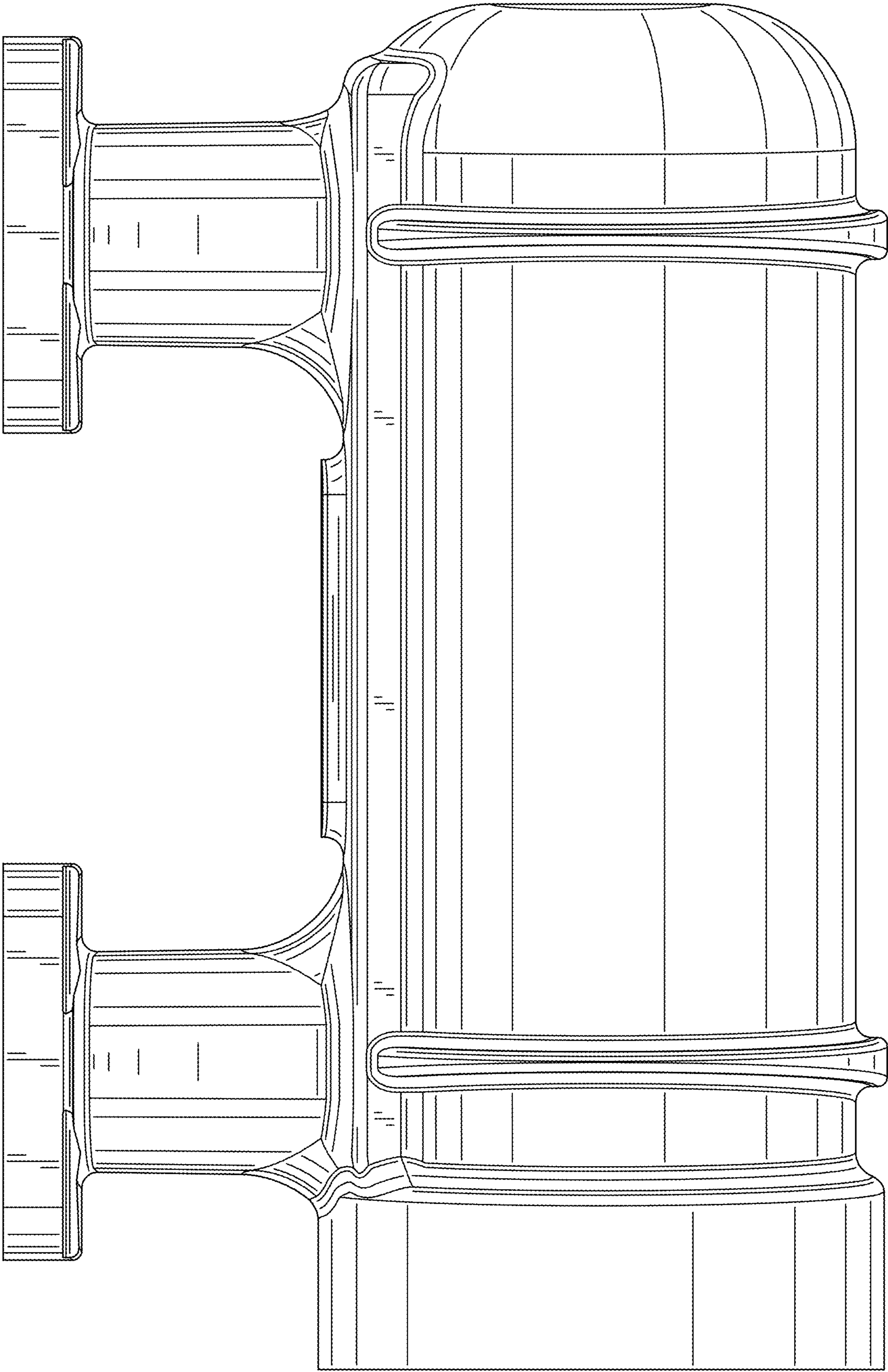

FIG. 10

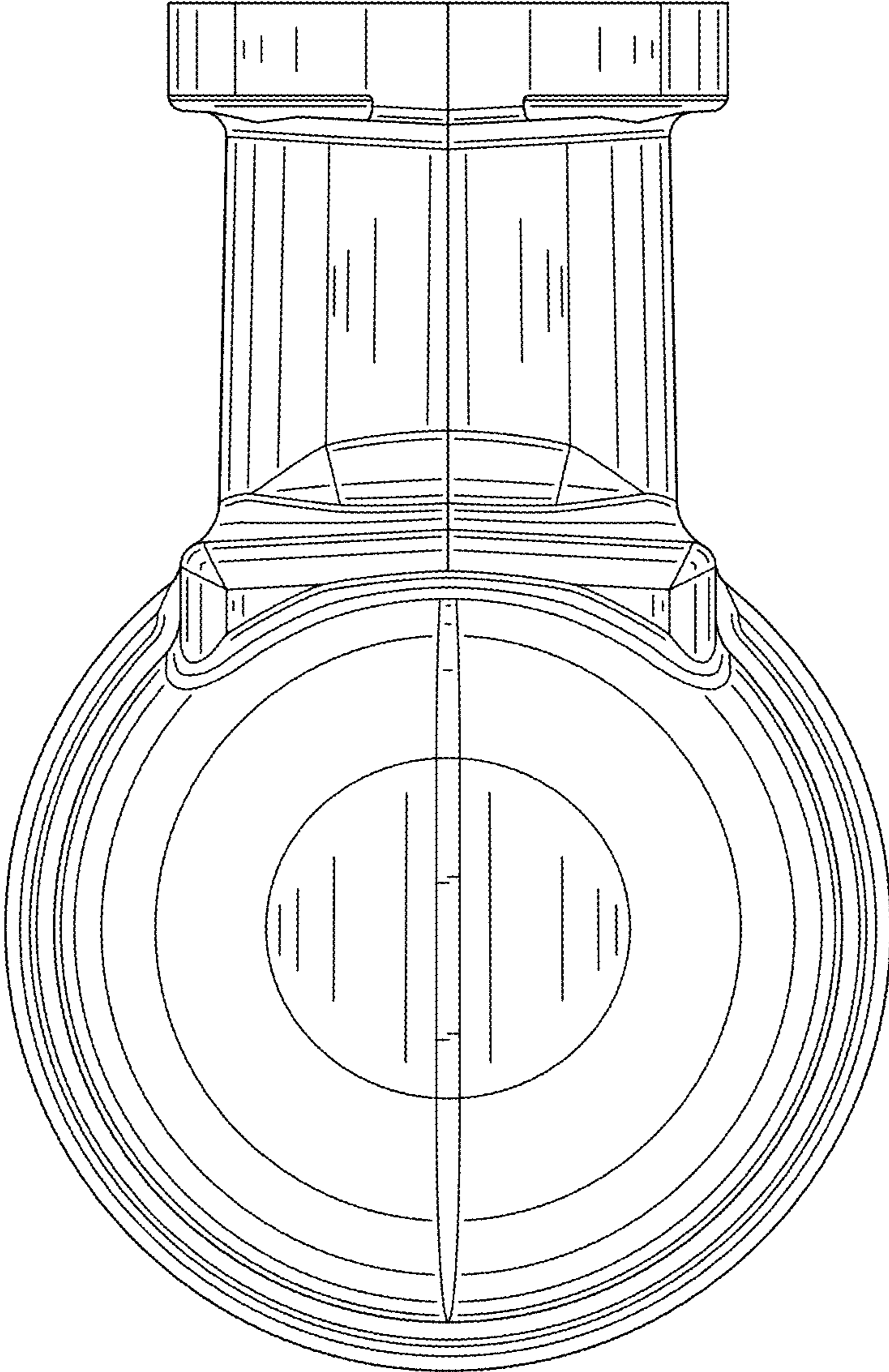

FIG. 11

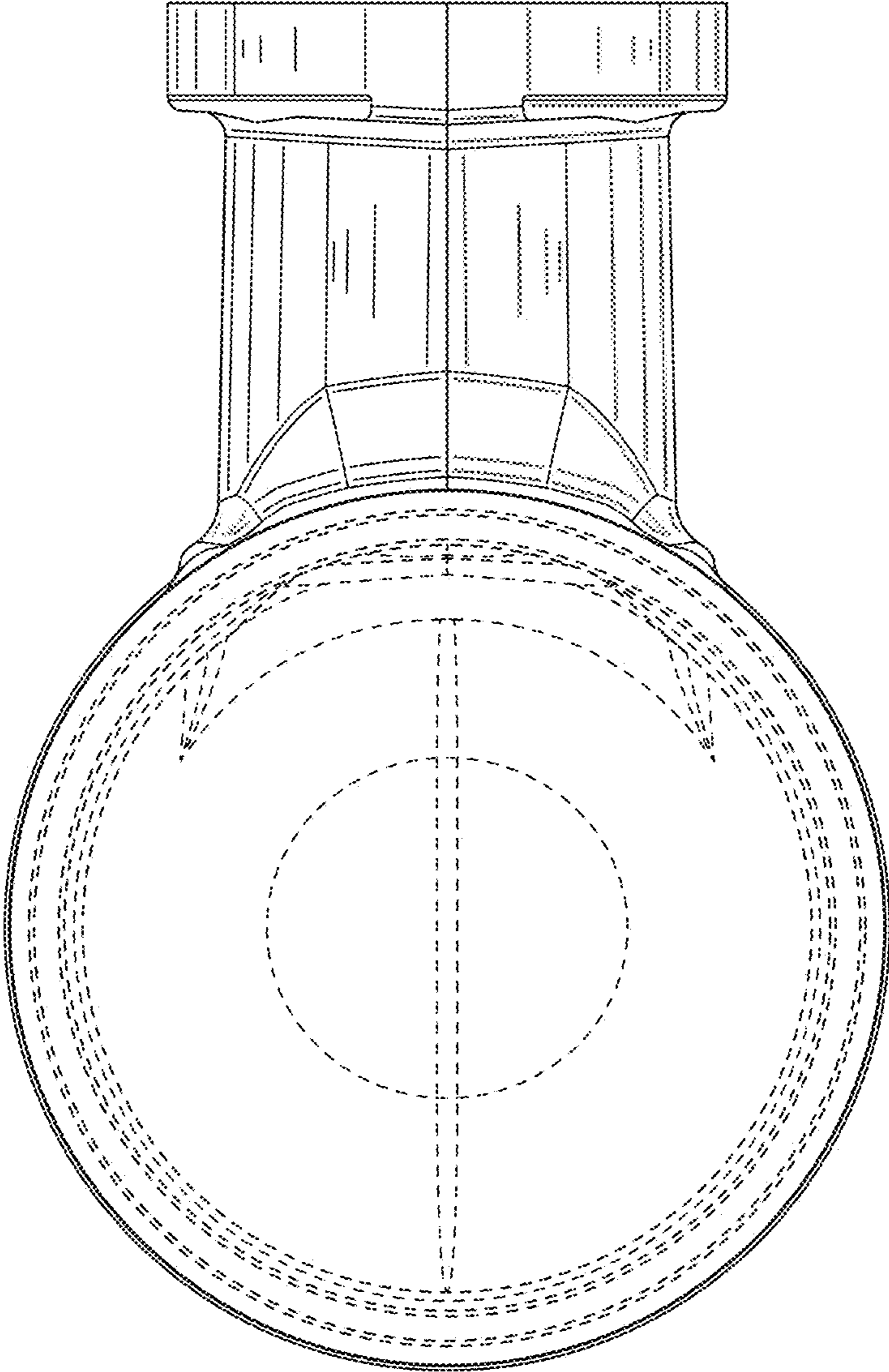

FIG. 12

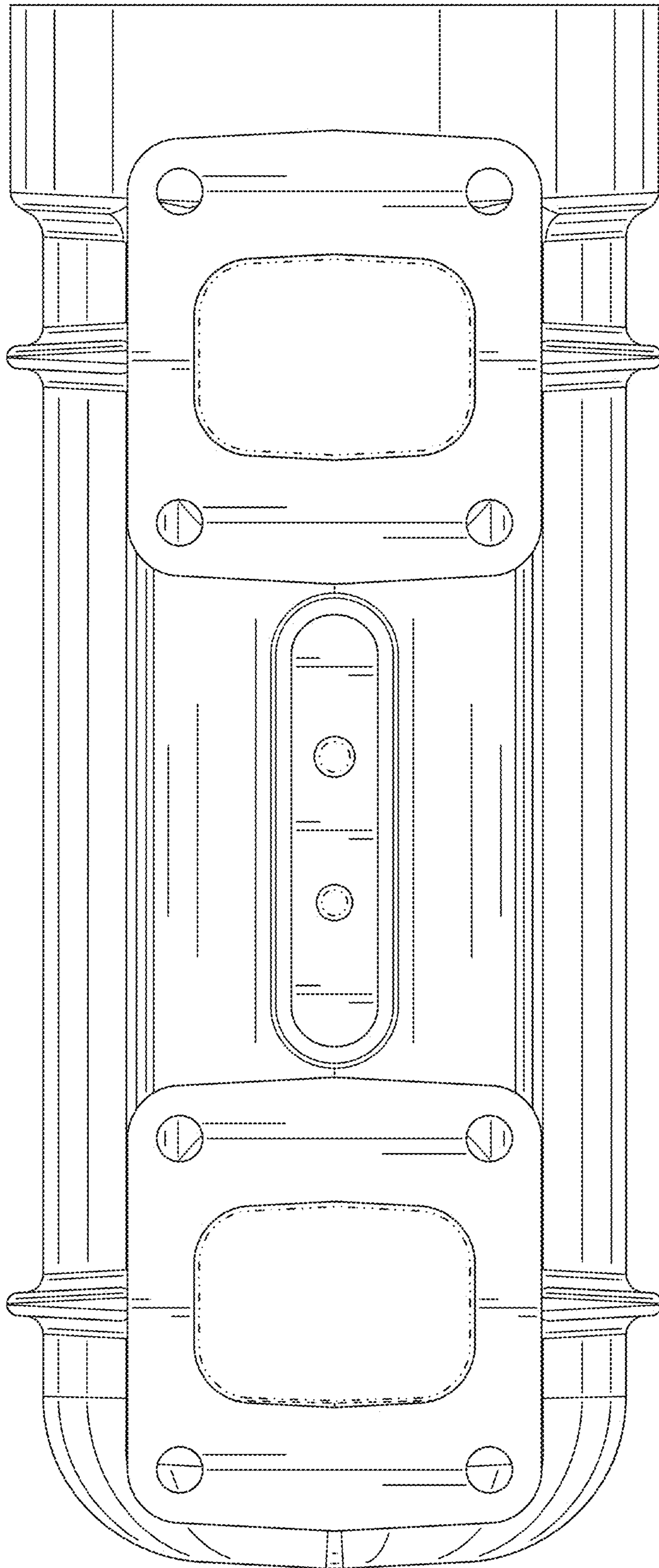

FIG. 13

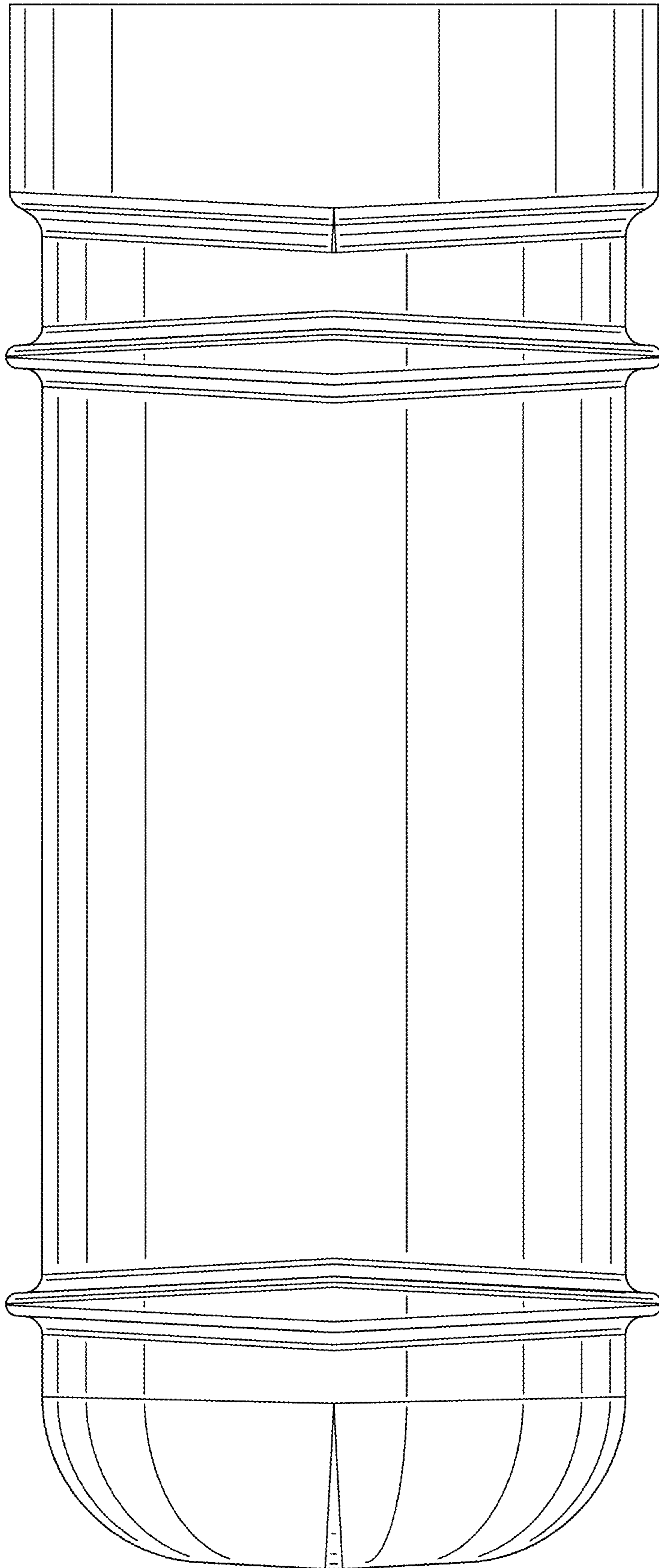

FIG. 14