



US00D971812S

(12) **United States Design Patent**  
**Zheng**

(10) **Patent No.:** **US D971,812 S**

(45) **Date of Patent:** **\*\* Dec. 6, 2022**

(54) **WHEEL CHOCK**

(71) Applicant: **Jie Zheng**, Guangdong (CN)

(72) Inventor: **Jie Zheng**, Guangdong (CN)

(\*\*) Term: **15 Years**

(21) Appl. No.: **29/833,310**

(22) Filed: **Apr. 2, 2022**

(51) **LOC (13) Cl.** ..... **12-16**

(52) **U.S. Cl.**  
USPC ..... **D12/217**

(58) **Field of Classification Search**

USPC ..... D12/217; D34/28, 31  
CPC ..... B60T 3/00; B60T 1/04; B66F 3/25; B66F 3/12; B66F 3/22; B66F 3/00; B66F 3/08; B66F 3/38; B66F 13/00; B66F 7/00; B60P 3/077; B64F 1/16; F16D 49/16  
See application file for complete search history.

(56) **References Cited**

**U.S. PATENT DOCUMENTS**

4,715,480	A *	12/1987	Anderson	.....	B60T 3/00 188/74
4,934,489	A *	6/1990	Jackson	.....	B60T 3/00 188/74
D347,821	S *	6/1994	Few	.....	D12/217
5,490,582	A *	2/1996	Trowbridge	.....	B60T 3/00 188/74
D481,849	S *	11/2003	Waltz	.....	D34/31
D535,176	S *	1/2007	Joiner	.....	D8/343
D657,930	S *	4/2012	Savage, Jr.	.....	D34/31
9,610,924	B1 *	4/2017	Searer	.....	B60T 3/00
D860,107	S	9/2019	Bilgin		
D949,770	S *	4/2022	Liang	.....	D12/217
D955,084	S *	6/2022	Li	.....	D34/31
D959,350	S *	8/2022	Lu	.....	D12/217
2010/0140026	A1 *	6/2010	Garceau	.....	B60P 3/077 188/69
2021/0362694	A1 *	11/2021	Lu	.....	B60T 3/00

**OTHER PUBLICATIONS**

CruXShaped, Published Apr. 21, 2021 [online], [retrieved on Sep. 15, 2022]. Retrieved from the Internet: <https://www.amazon.com/CruXShaped-Stabilizer-Camper-Accessories-Trailers/dp/B09YRSFP5P> (Year: 2021).\*

\* cited by examiner

*Primary Examiner* — Cary M Robinson

*Assistant Examiner* — Adam C Mager

(57) **CLAIM**

The ornamental design for a wheel chock, as shown and described.

**DESCRIPTION**

FIG. 1 is a front and top perspective view of a wheel chock, showing my new design;  
FIG. 2 is a rear and bottom perspective view thereof;  
FIG. 3 is a front elevation view thereof;  
FIG. 4 is a rear elevation view thereof;  
FIG. 5 is a left side elevation view thereof;  
FIG. 6 is a right side elevation view thereof;  
FIG. 7 is a top plan view thereof;  
FIG. 8 is a bottom plan view thereof;  
FIG. 9 is another perspective view thereof, shown in a using position; and,  
FIG. 10 is another perspective view thereof, shown in an alternative position.

The broken lines in the figures illustrate portions of the wheel chock that form no part of the claimed design. The broken lines of wheels in FIG. 9 shown in the drawings depict environmental structure that form no part of the claimed design.

**1 Claim, 10 Drawing Sheets**

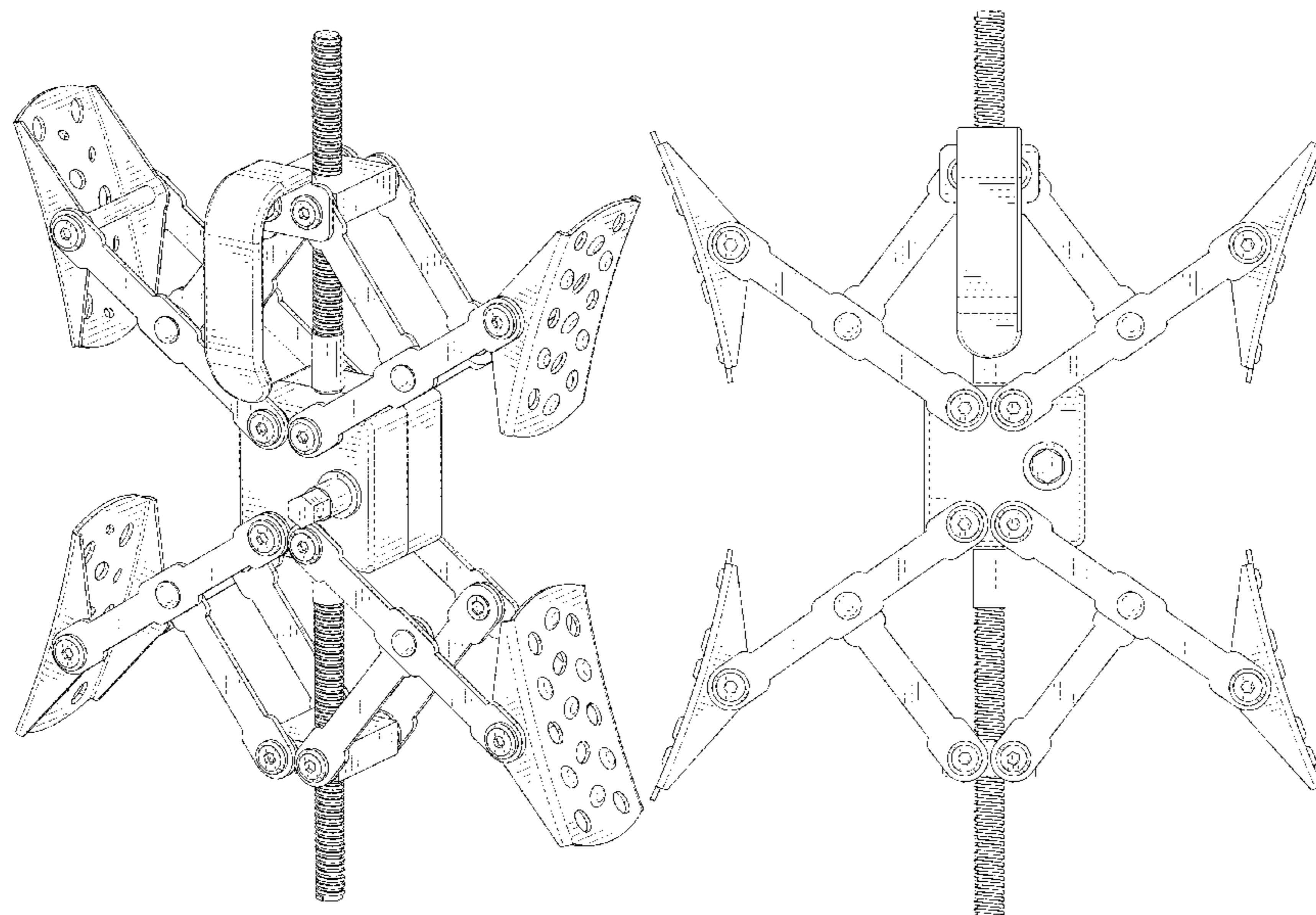

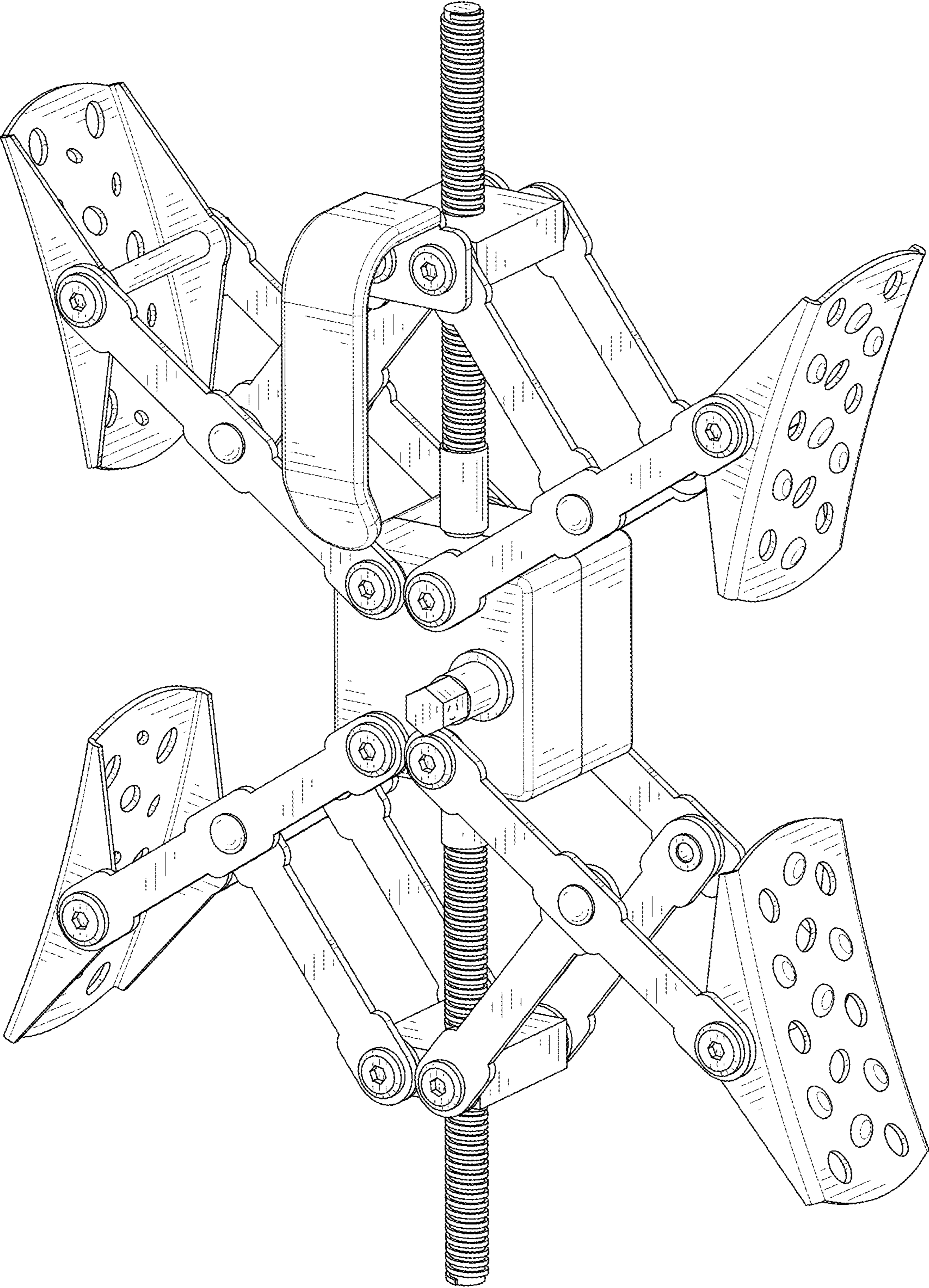

FIG. 1

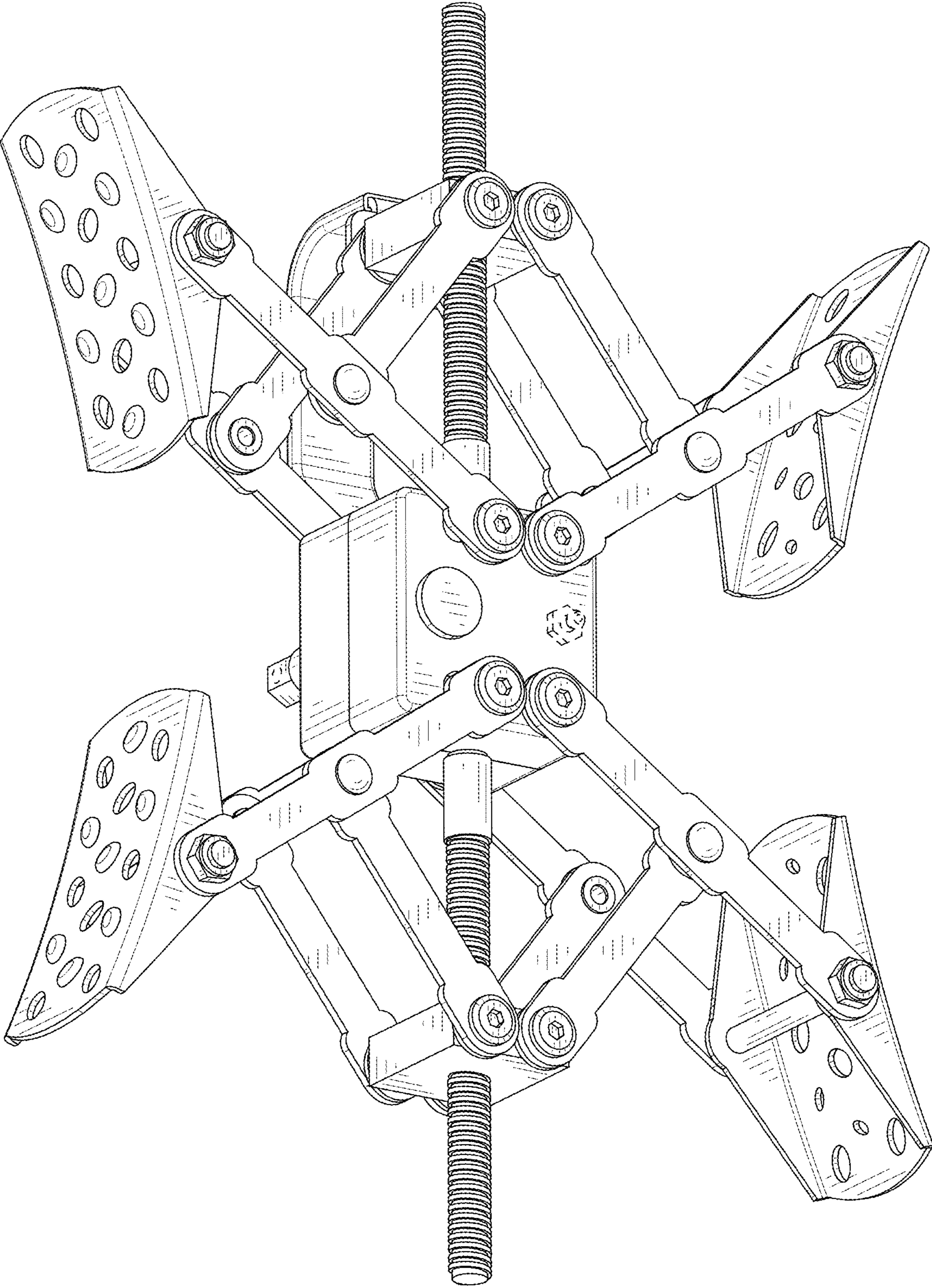

FIG. 2

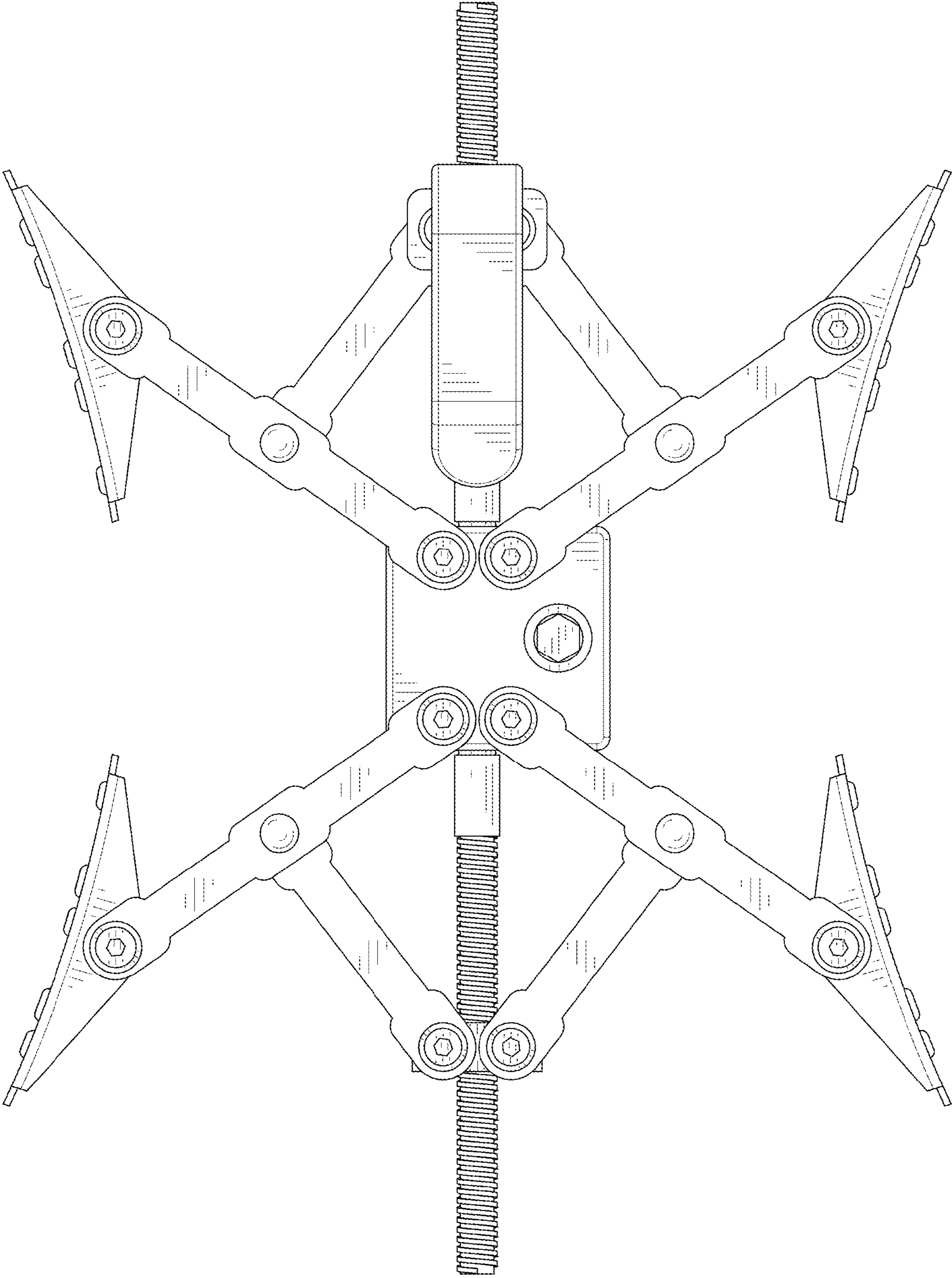

FIG. 3

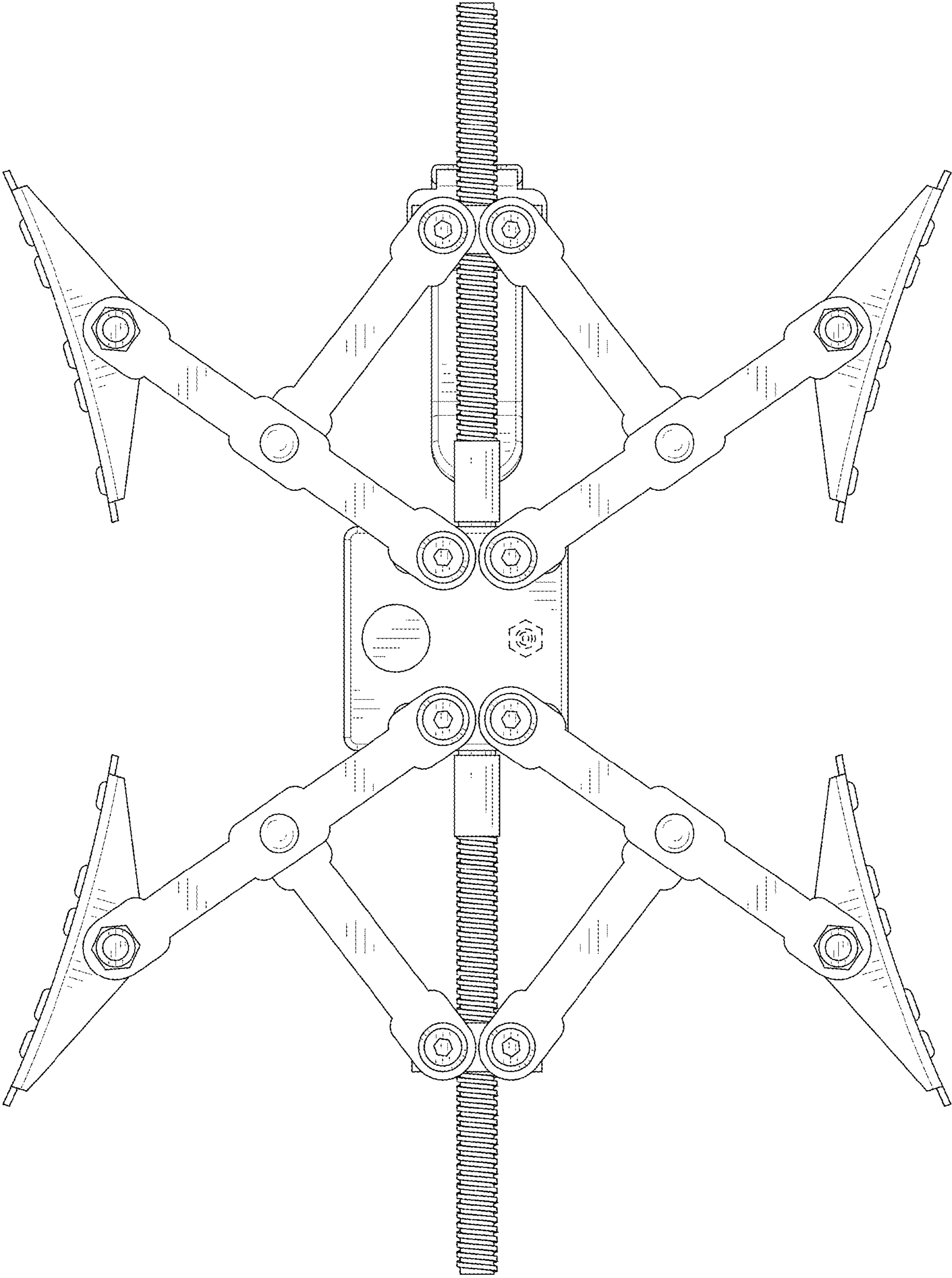

FIG. 4

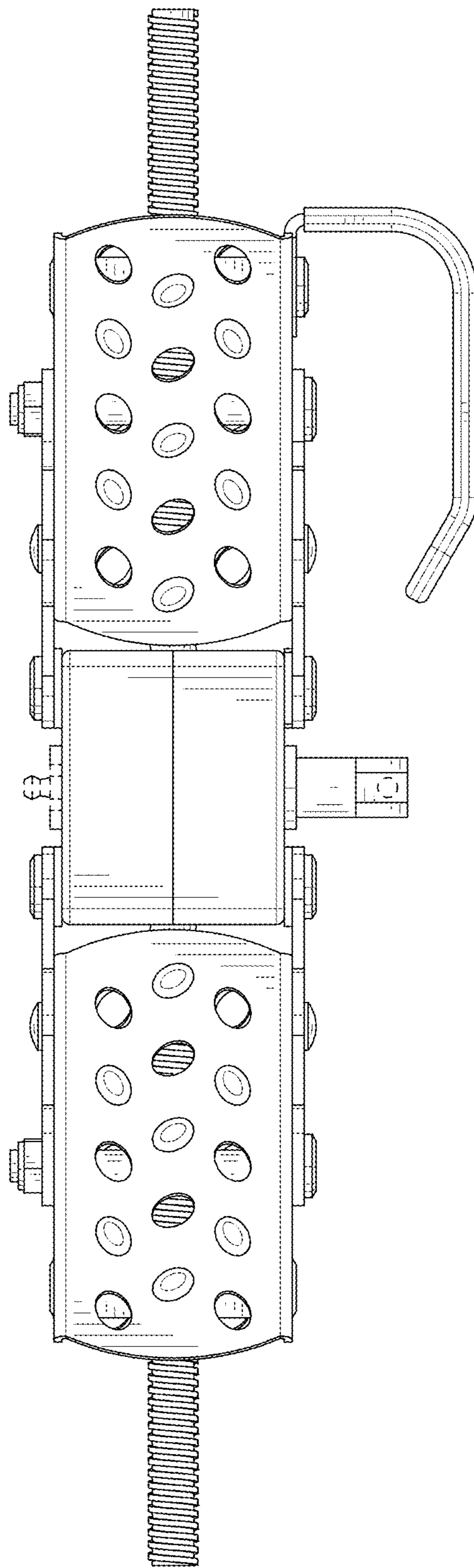

FIG. 5

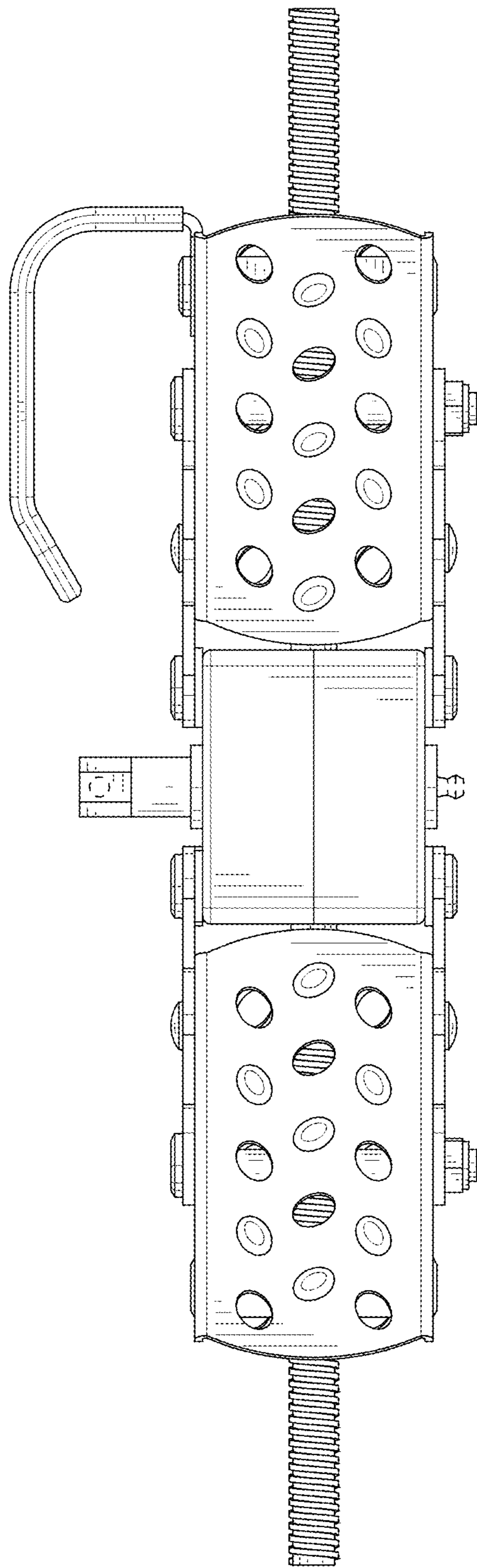

FIG. 6

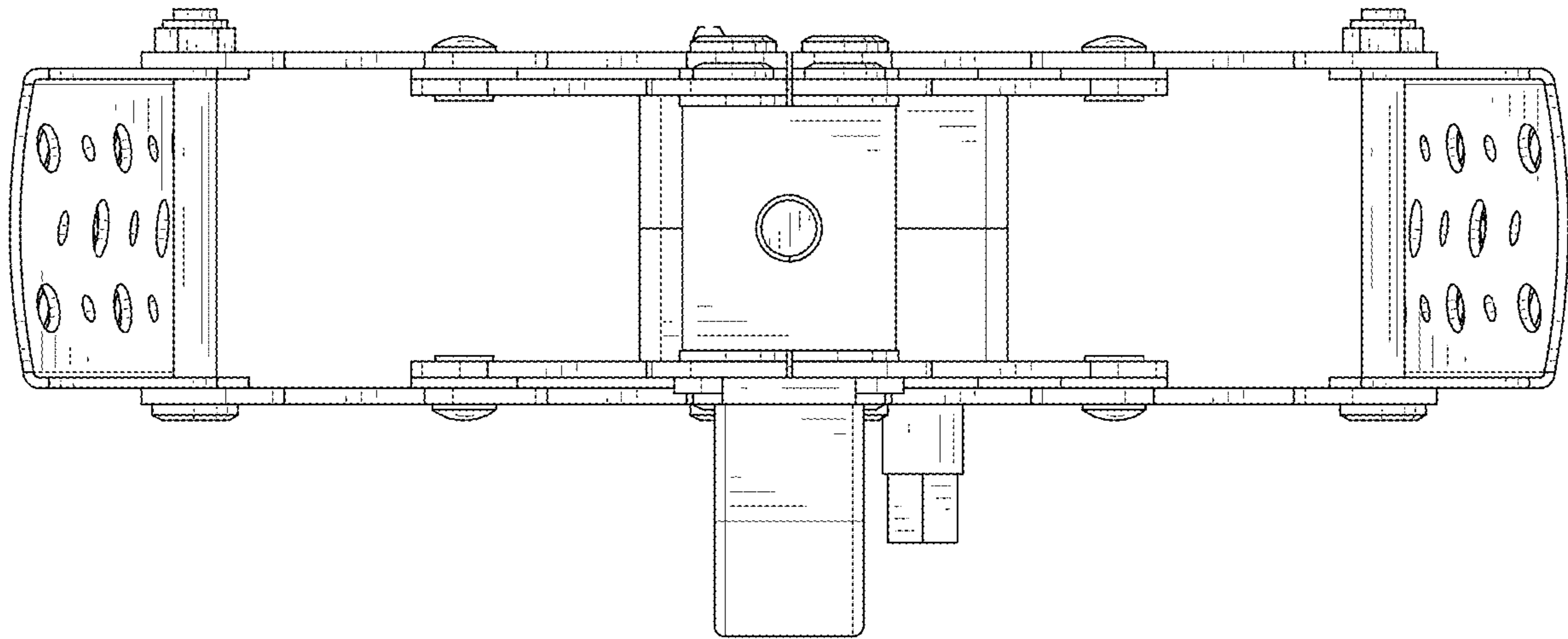

FIG. 7



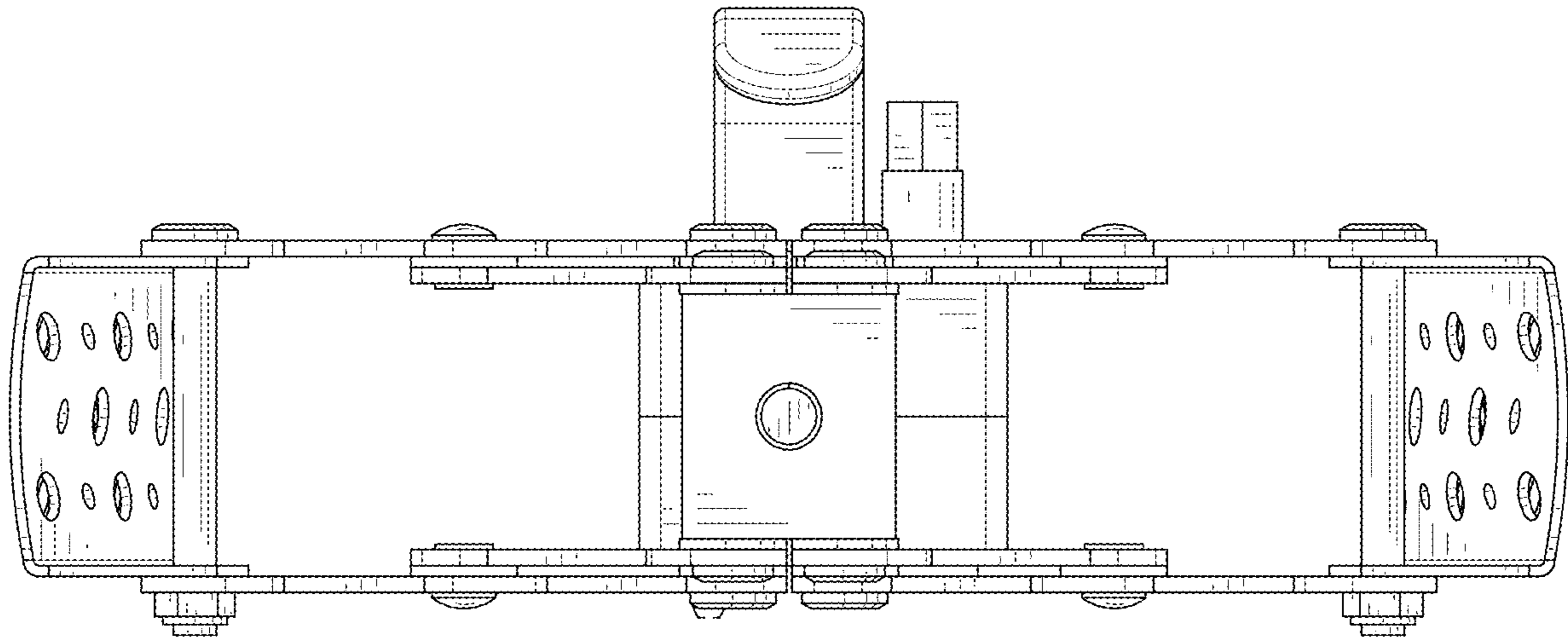

FIG. 8

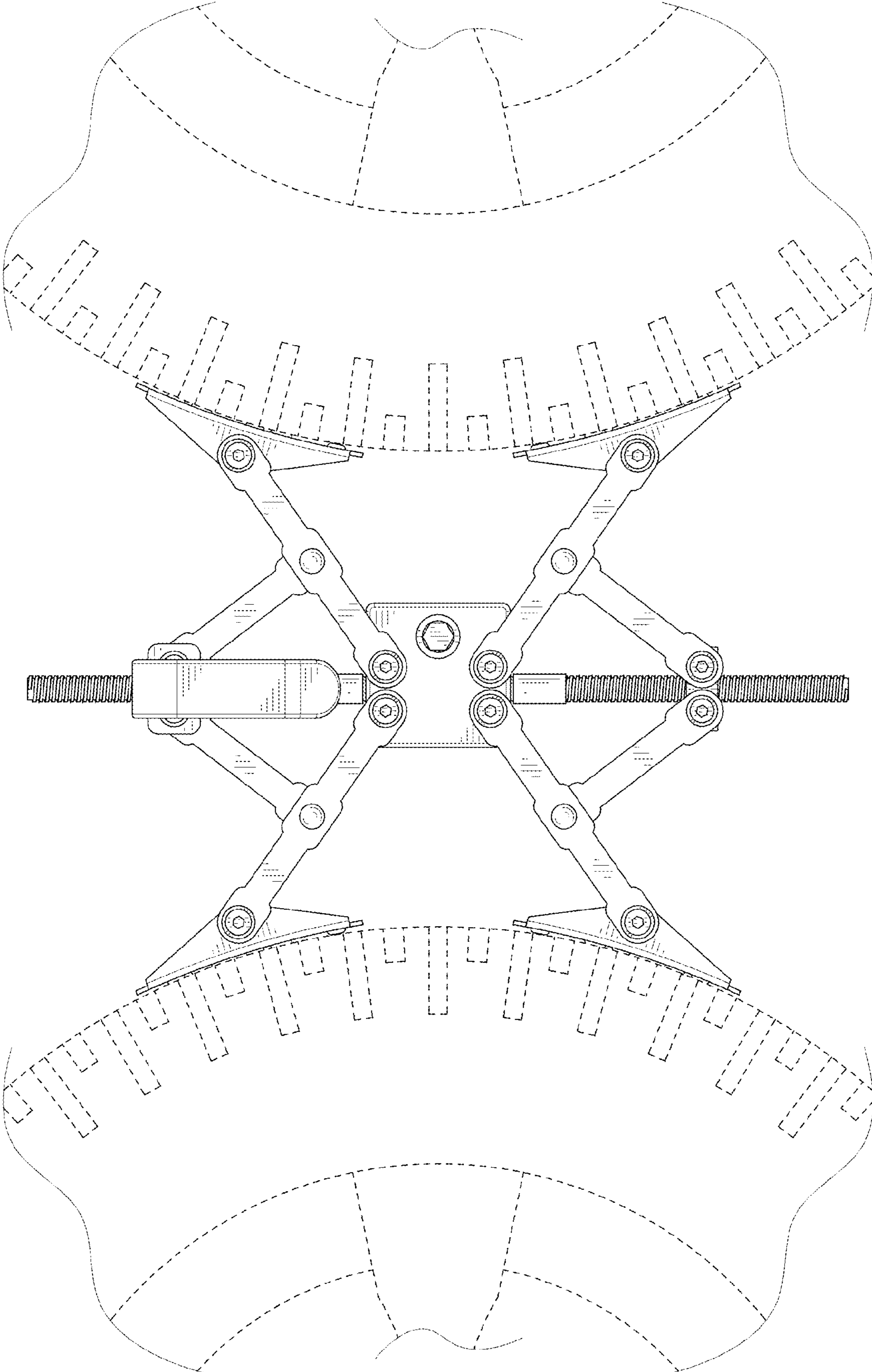

FIG. 9

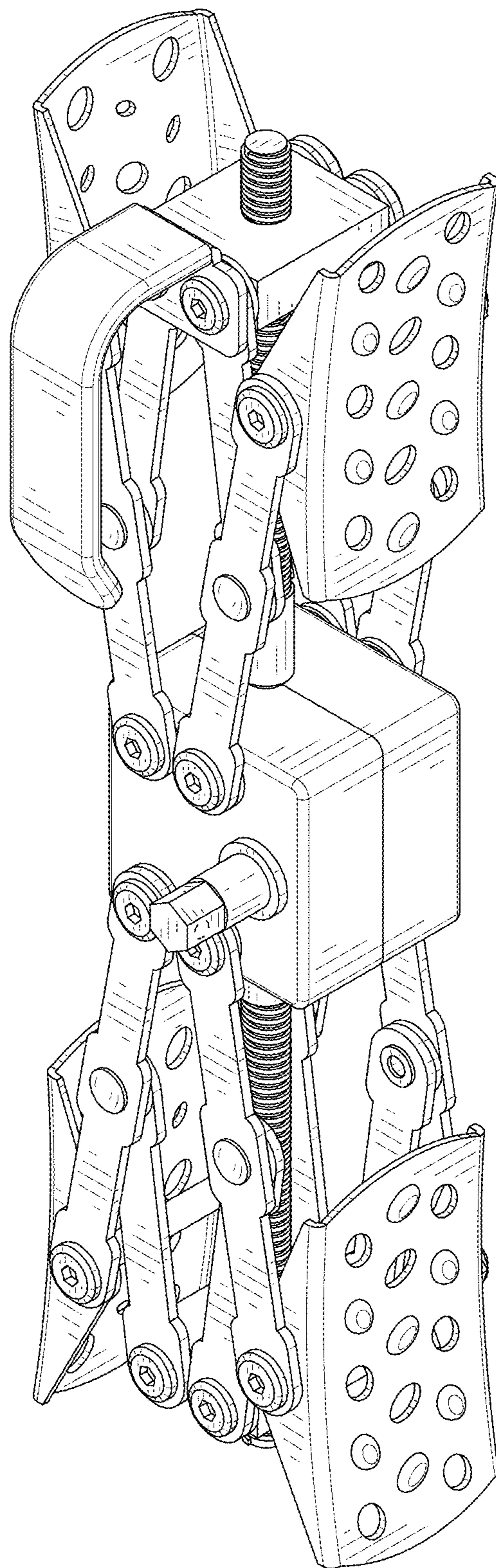

FIG. 10