



US00D971260S

(12) **United States Design Patent** (10) **Patent No.:** **US D971,260 S**  
**Kuehne et al.** (45) **Date of Patent:** **\*\* Nov. 29, 2022**

(54) **TIE BAR APPARATUS FOR AN OUTBOARD MOTOR**

(71) Applicant: **Brunswick Corporation**, Mettawa, IL (US)

(72) Inventors: **Tyler L. Kuehne**, Milwaukee, WI (US); **Robert A. Podell**, Slinger, WI (US)

(73) Assignee: **Brunswick Corporation**, Mettawa, IL (US)

(\*\*) Term: **15 Years**

(21) Appl. No.: **29/841,580**

(22) Filed: **Jun. 7, 2022**

**Related U.S. Application Data**

(63) Continuation of application No. 29/710,803, filed on Oct. 25, 2019, now Pat. No. Des. 958,192.

(51) **LOC (13) Cl.** ..... **15-01**

(52) **U.S. Cl.**  
USPC ..... **D15/4**

(58) **Field of Classification Search**  
USPC ..... D15/1, 2, 3, 4, 5, 6, 7, 199; D8/349, D8/352, 354, 355, 380; D12/223  
CPC ..... B63H 20/06; B63H 20/12; B63H 20/08  
See application file for complete search history.

(56) **References Cited**

**U.S. PATENT DOCUMENTS**

- 3,470,844 A 10/1969 Johns et al.
- 4,310,320 A 1/1982 Pitchford
- 4,654,013 A \* 3/1987 Bland ..... B63H 20/12  
440/63
- 6,371,820 B1 4/2002 Neisen et al.

- 6,913,497 B1 \* 7/2005 Ahiswede ..... B63H 20/12  
440/63
- 7,207,854 B1 \* 4/2007 Anderson, Jr. .... B63H 5/125  
440/63
- 9,499,247 B1 11/2016 Wiatrowski et al.
- 9,718,525 B1 8/2017 Wiatrowski et al.
- 10,988,222 B1 4/2021 Langenfeld et al.
- 2010/0273368 A1 10/2010 Sakata et al.
- 2020/0116173 A1 4/2020 Isom
- 2020/0283110 A1 9/2020 Bergeron
- 2021/0122450 A1 4/2021 Fukuchi

\* cited by examiner

*Primary Examiner* — Ania Aman

(74) *Attorney, Agent, or Firm* — Andrus Intellectual Property Law, LLP

(57) **CLAIM**

The ornamental design for a tie bar apparatus for an outboard motor, as shown and described.

**DESCRIPTION**

FIG. 1 is a front perspective view of a tie bar apparatus for an outboard motor according to our new and ornamental design;

FIG. 2 is a side view thereof;

FIG. 3 is an opposite side view thereof;

FIG. 4 is a front view thereof;

FIG. 5 is a rear view thereof;

FIG. 6 is a top view thereof; and,

FIG. 7 is a bottom view thereof.

In the drawings, the evenly spaced broken lines shown in the Figures depict portions of the tie bar apparatus for an outboard motor that form no part of the claimed design. The dash-dot-dash broken lines define the boundary of the claimed design and form no part of the claimed design.

**1 Claim, 7 Drawing Sheets**

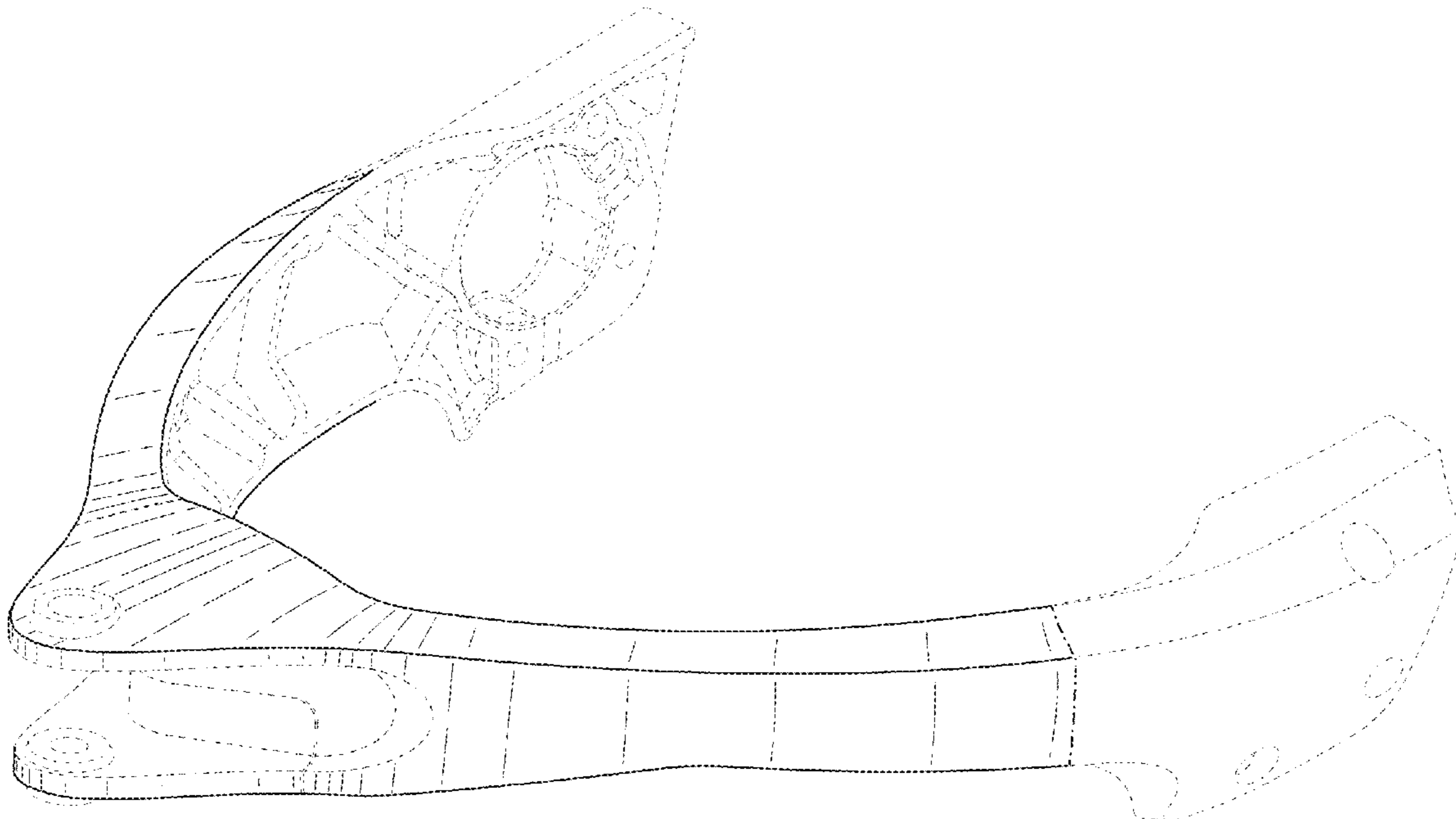

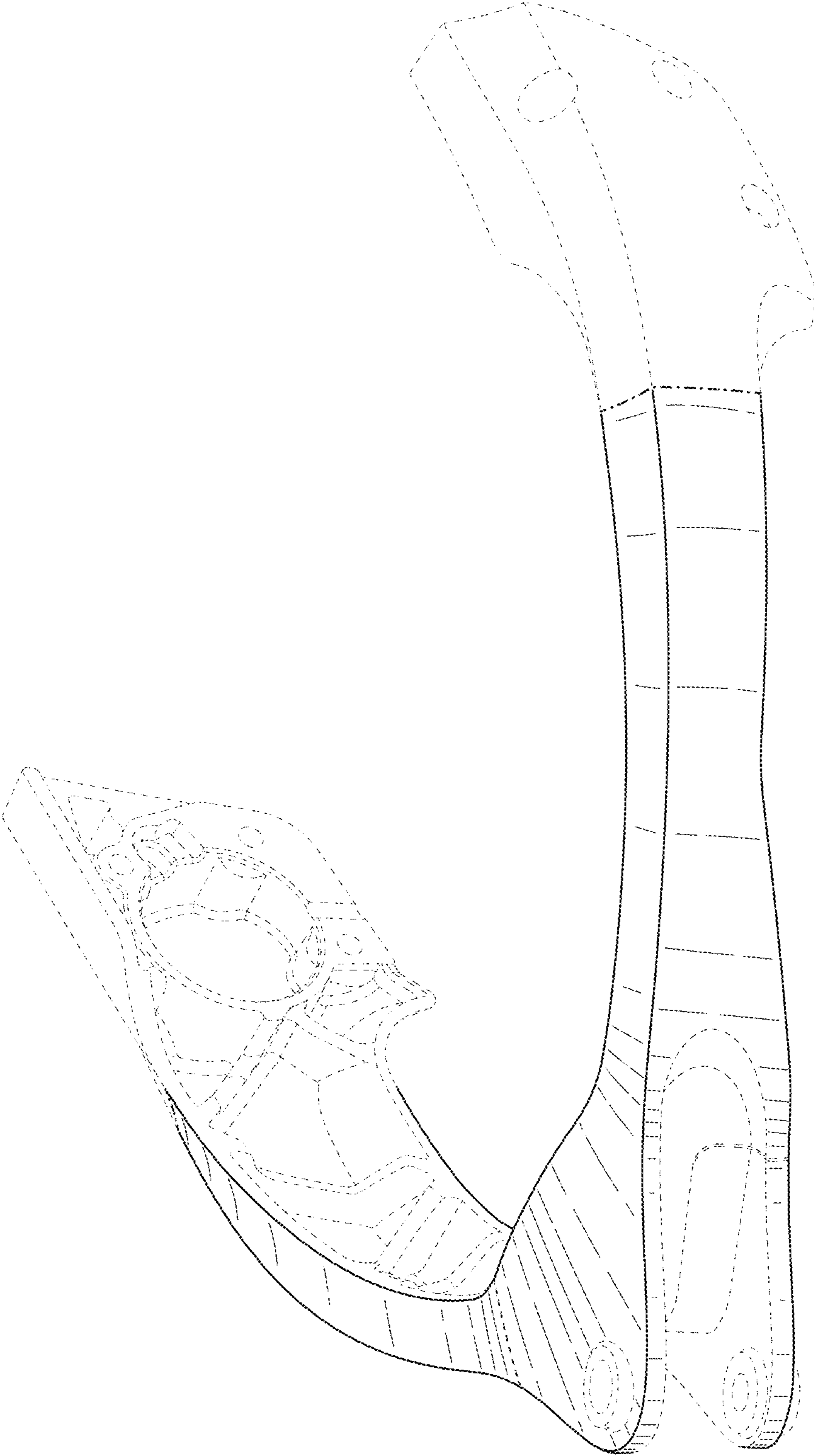

FIG. 1

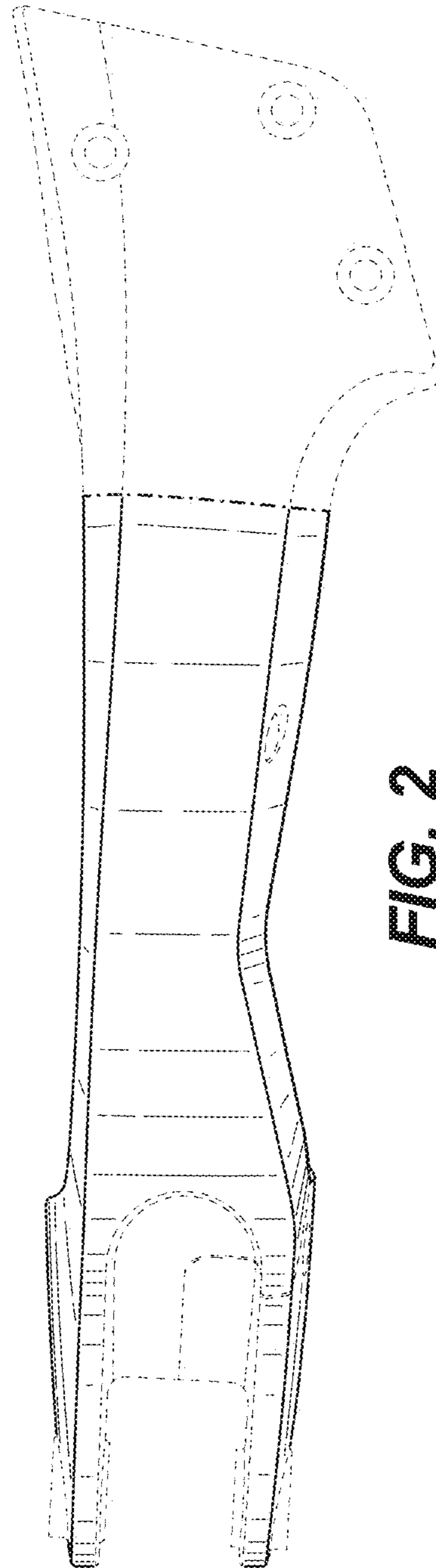

FIG. 2

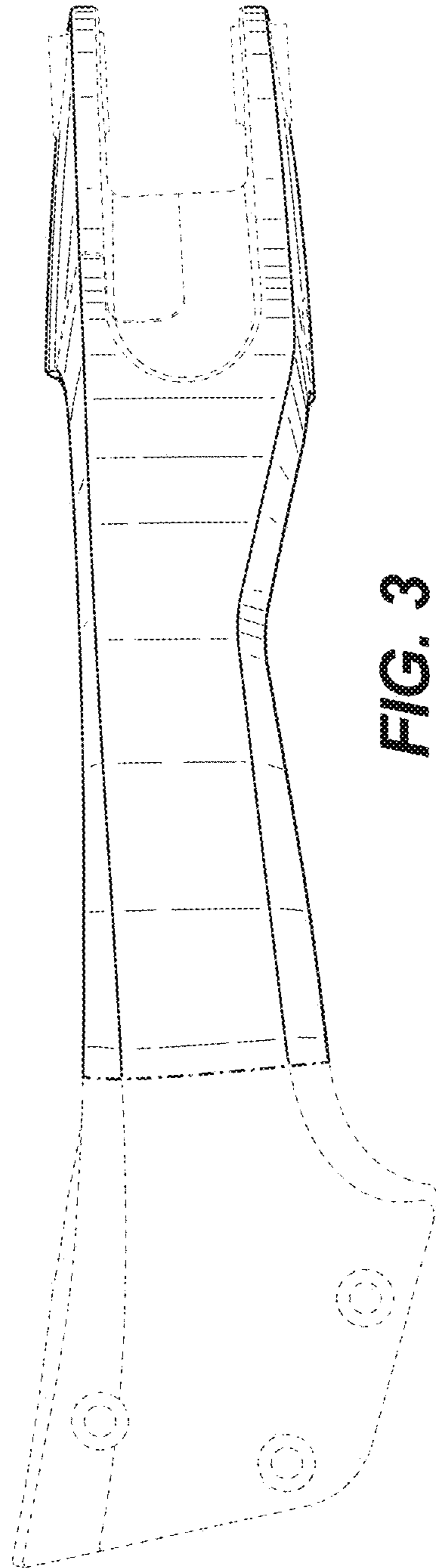
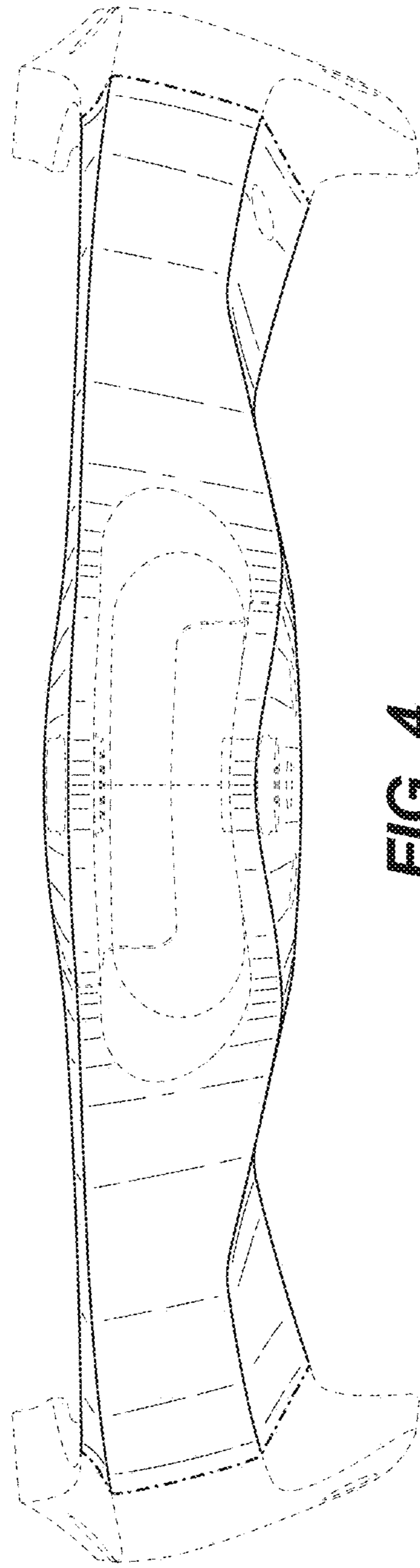
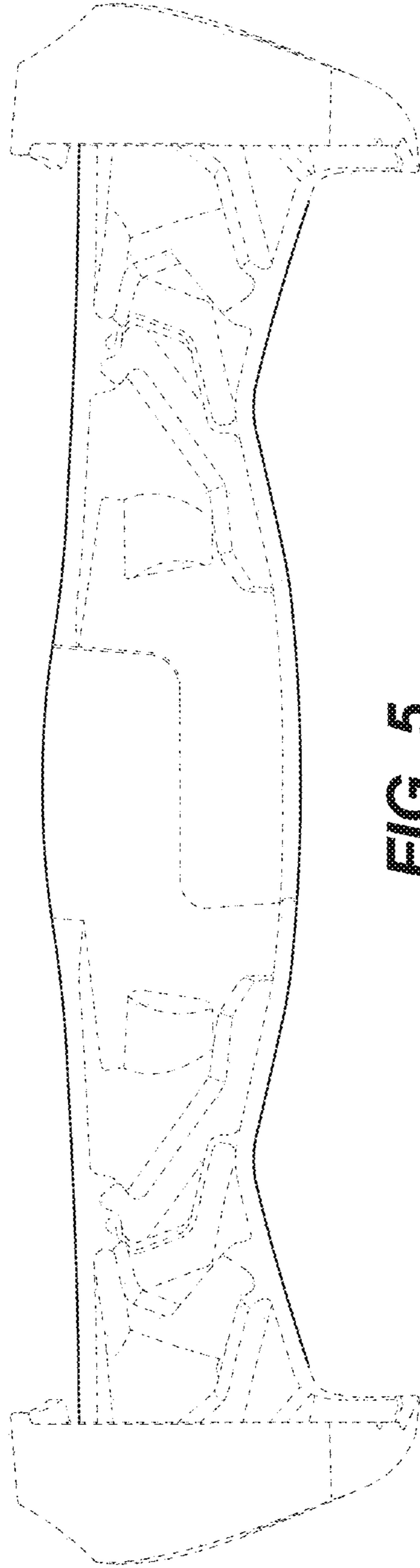

FIG. 3



**FIG. 4**



**FIG. 5**



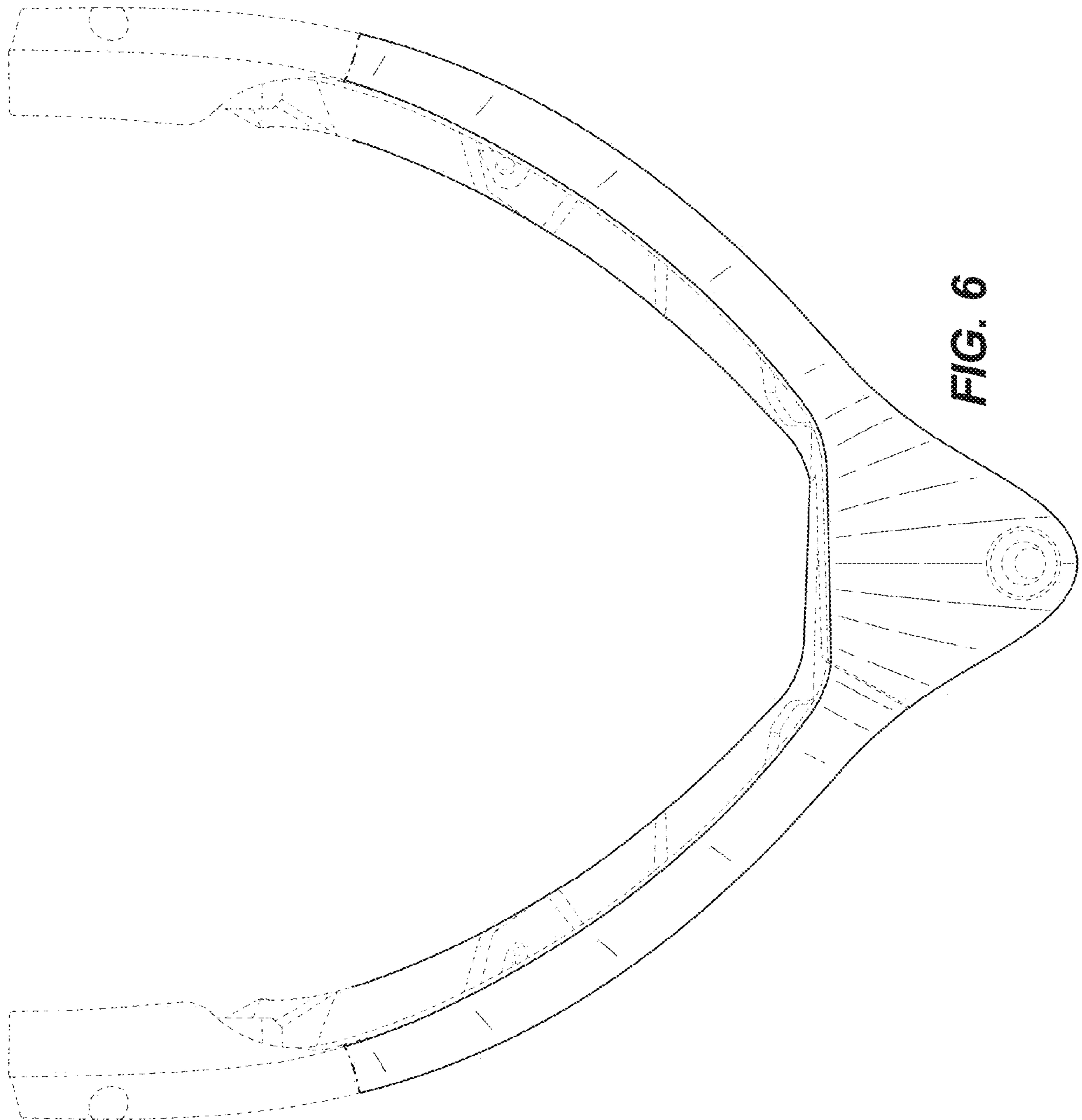

FIG. 6

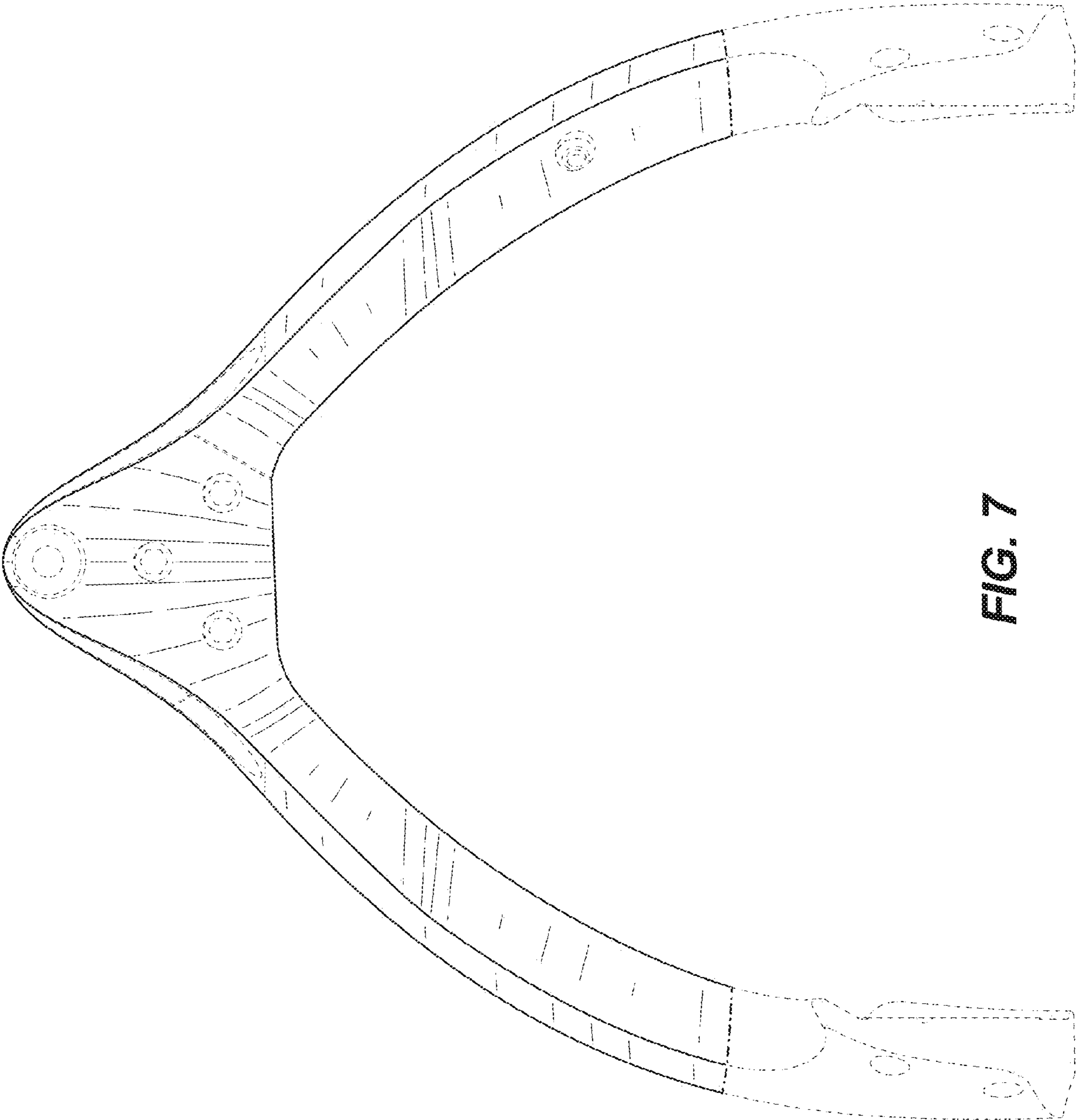

FIG. 7