



US00D971168S

(12) **United States Design Patent** (10) **Patent No.:** **US D971,168 S**  
**Rochford et al.** (45) **Date of Patent:** **\*\* Nov. 29, 2022**

(54) **CLIP FOR A SEMICONDUCTOR CHIP TRAY**

FOREIGN PATENT DOCUMENTS

(71) Applicant: **BAE Systems Information and Electronic Systems Integration Inc.**, Nashua, NH (US)

JP 2005041574 A 2/2005  
WO 2020106877 A1 5/2020

(72) Inventors: **Richard Rochford**, Litchfield, NH (US); **Edward L. Brabant, Jr.**, Dracut, MA (US)

OTHER PUBLICATIONS

(73) Assignee: **BAE Systems Information and Electronic Systems Integration Inc.**, Nashua, NH (US)

Substrate and Small Package Handling. Entegris Product Catalog [online]. Entegris Inc., 2020 [retrieved on Nov. 16, 2020]. Retrieved from the Internet: <https://www.entegris.com/content/dam/shared-product-assets/bare-die-csp-shared/catalog-substrate-and-small-package-handling-5595.pdf>, 26 pages.

(Continued)

(\*\*) Term: **15 Years**

*Primary Examiner* — Keli L Hill

(21) Appl. No.: **29/759,675**

*Assistant Examiner* — Harold E Blackwell, II

(22) Filed: **Nov. 24, 2020**

(74) *Attorney, Agent, or Firm* — Scott J. Asmus

(51) **LOC (13) Cl.** ..... **13-03**

(57) **CLAIM**

(52) **U.S. Cl.**  
USPC ..... **D13/184**

The ornamental design for a clip for a semiconductor chip tray, as shown and described.

(58) **Field of Classification Search**  
USPC ..... D14/240, 242, 356, 358, 363, 365, 367, D14/370, 432-437, 439, 125, 366, 168, D14/496; D13/103, 107, 108, 118, 119, D13/123, 133, 134, 154, 158, 162, 173, D13/184, 110

**DESCRIPTION**

CPC ..... H04N 7/00; H04D 10/70  
See application file for complete search history.

FIG. 1 is a front perspective view of the clip for a semiconductor chip tray;  
FIG. 2 is a front elevated view of the clip for a semiconductor chip tray shown in FIG. 1;  
FIG. 3 is a rear elevated view of the clip for a semiconductor chip tray shown in FIG. 1;  
FIG. 4 is a right side view of the clip for a semiconductor chip tray shown in FIG. 1;  
FIG. 5 is a left side view of the clip for a semiconductor chip tray shown in FIG. 1;  
FIG. 6 is a top view of the clip for a semiconductor chip tray shown in FIG. 1; and,  
FIG. 7 is a bottom view of the clip for a semiconductor chip tray shown in FIG. 1.

(56) **References Cited**

U.S. PATENT DOCUMENTS

5,983,468 A 11/1999 Evans et al.  
6,079,565 A 6/2000 Walsh et al.  
D503,691 S 4/2005 Standing et al.  
7,574,784 B2 8/2009 Pylant et al.  
D602,452 S \* 10/2009 Grundker ..... D13/184  
D614,979 S \* 5/2010 McNames ..... D10/70  
D634,704 S \* 3/2011 Tieleman ..... D13/102  
8,223,248 B2 \* 7/2012 Lee ..... H01L 24/13  
348/340

The broken lines showing of a clip for a semiconductor chip tray which form no part of the claimed design.

(Continued)

**1 Claim, 7 Drawing Sheets**

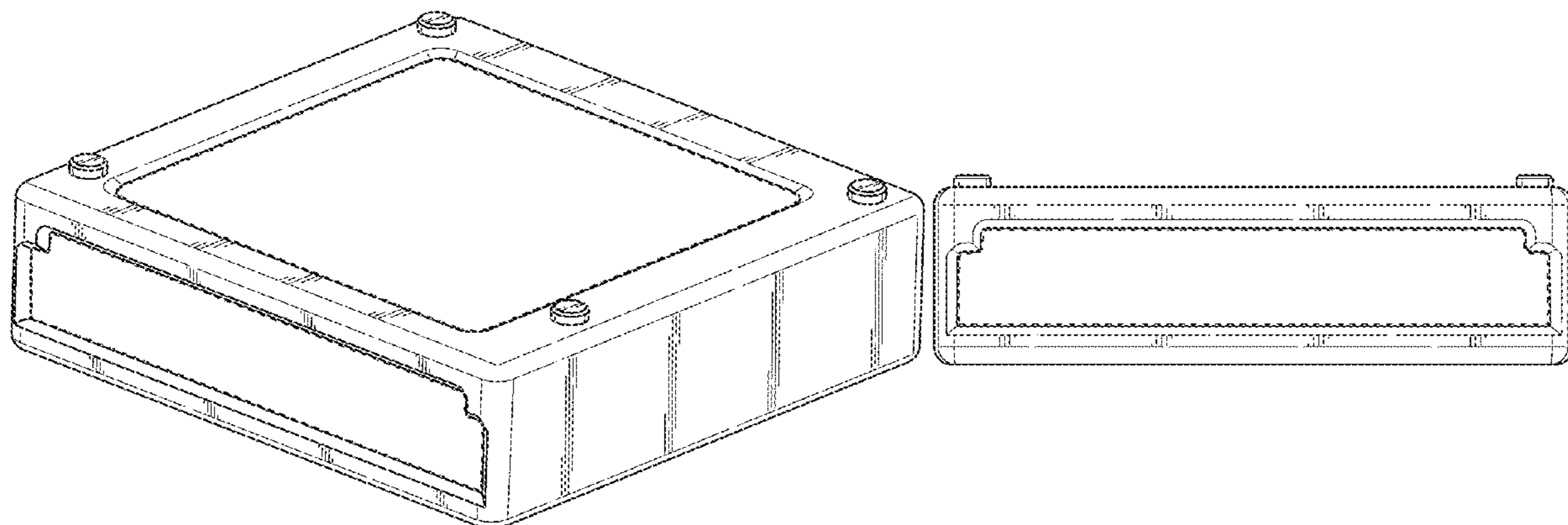

(56)

References Cited

U.S. PATENT DOCUMENTS

D701,699 S \* 4/2014 Bonacina ..... D3/304  
 D702,239 S \* 4/2014 Lee ..... D14/432  
 D705,748 S \* 5/2014 He ..... D14/155  
 D733,043 S \* 6/2015 Hasbrook ..... D13/103  
 D752,529 S \* 3/2016 Loretan ..... D14/125  
 D756,338 S \* 5/2016 Jou ..... D14/242  
 D756,976 S \* 5/2016 Jou ..... D14/242  
 D763,262 S \* 8/2016 Hallar ..... D14/434  
 D765,066 S \* 8/2016 Cowles ..... D14/240  
 D771,024 S \* 11/2016 Epstein ..... D14/242  
 D783,619 S \* 4/2017 Couture ..... D14/433  
 9,876,522 B2 \* 1/2018 Huang ..... H04B 1/3888  
 D830,869 S \* 10/2018 Siminoff ..... D10/106.1  
 D844,006 S \* 3/2019 Molnár ..... D14/434  
 D849,006 S \* 5/2019 Pang ..... D14/433  
 D854,018 S \* 7/2019 Liao ..... D14/433  
 D862,405 S \* 10/2019 Russo ..... D14/125  
 D864,145 S \* 10/2019 Zhang ..... D14/433  
 D879,150 S \* 3/2020 Kusano ..... D14/203.1  
 D886,812 S \* 6/2020 Jung ..... D14/240  
 D916,028 S \* 4/2021 Yu ..... D13/139.8  
 D924,933 S \* 7/2021 Kusano ..... D14/496  
 D926,188 S \* 7/2021 Zhang ..... D14/433

11,114,830 B2 \* 9/2021 Chen ..... H02G 3/14  
 D937,260 S \* 11/2021 Kuwano ..... D14/358  
 D944,803 S \* 3/2022 Liao ..... D14/433  
 D945,392 S \* 3/2022 Jia ..... D14/155  
 D952,477 S \* 5/2022 Gong ..... D10/52  
 D953,304 S \* 5/2022 Huang ..... D14/225  
 D953,337 S \* 5/2022 Zhang ..... D14/433  
 2009/0302190 A1 \* 12/2009 Trieu ..... B01L 9/527  
 248/682  
 2021/0188516 A1 \* 6/2021 Rochford ..... B32B 7/12

OTHER PUBLICATIONS

Specialized Handling Products. Entegris Product Catalog [online].  
 Entegris Inc., 2020 [retrieved on Nov. 16, 2020]. Retrieved from the  
 Internet: <https://www.entegris.com/content/dam/shared-product-assets/handling-shared/catalog-specialized-handling-products-5367-a4.pdf>, 40 pages.  
 Gel-Pak Product Catalog [online]. Gel-Pak a DBA Delphon Indus.,  
 LLC, 2020 [retrieved on Nov. 16, 2020]. Retrieved from the  
 Internet: [https://www.gelpak.com/wp-content/uploads/2019/03/2019\\_Gel-Pak\\_8\\_Page\\_Brochure\\_RevB.pdf](https://www.gelpak.com/wp-content/uploads/2019/03/2019_Gel-Pak_8_Page_Brochure_RevB.pdf), 5 pages.

\* cited by examiner

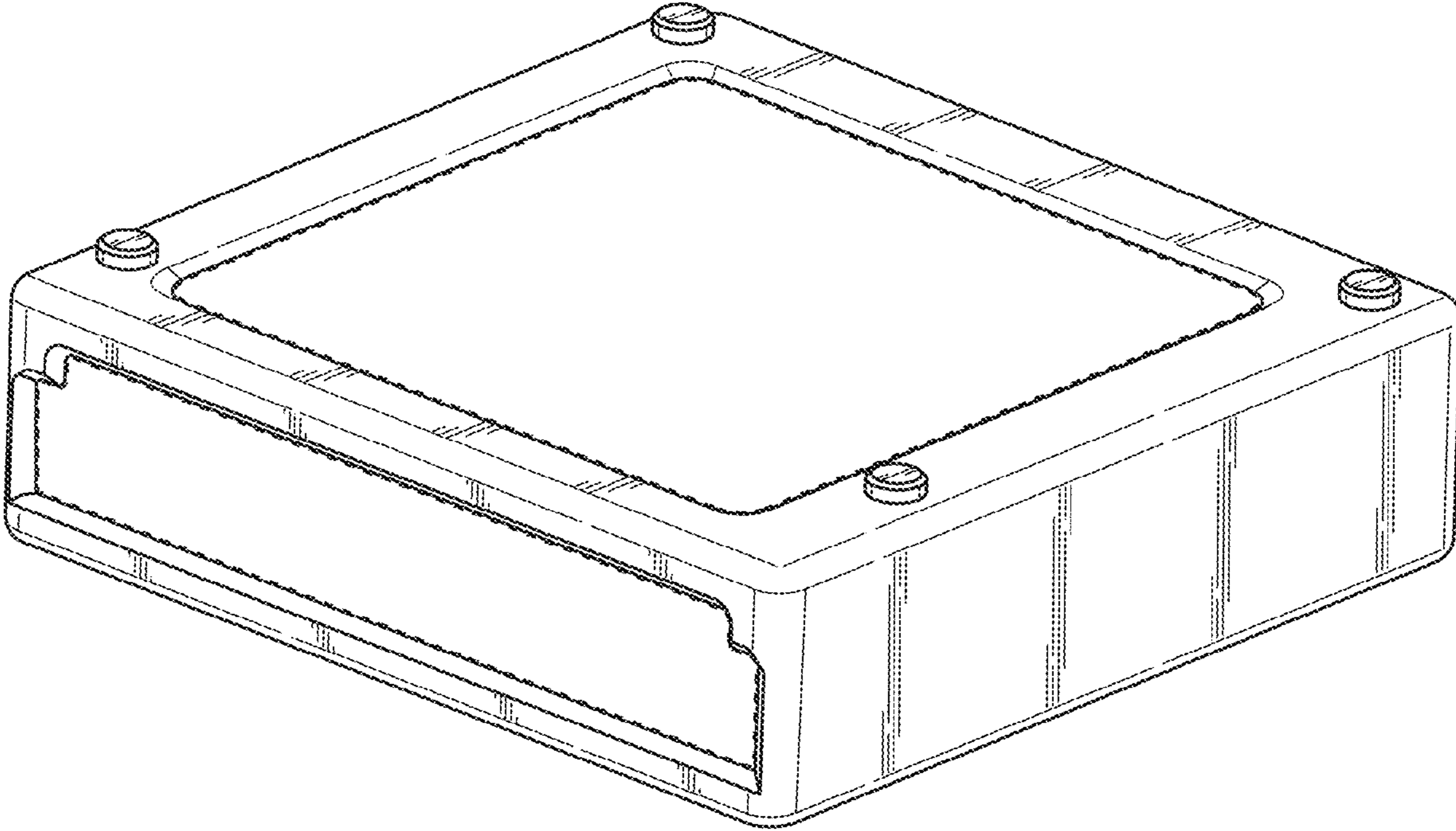

FIG. 1

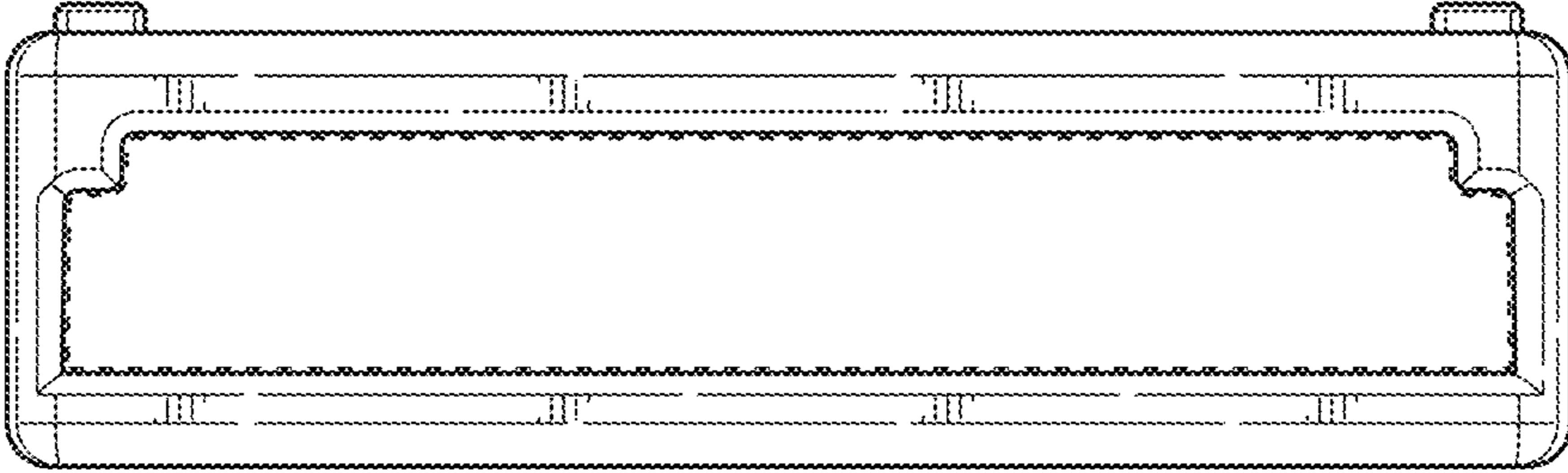

FIG. 2

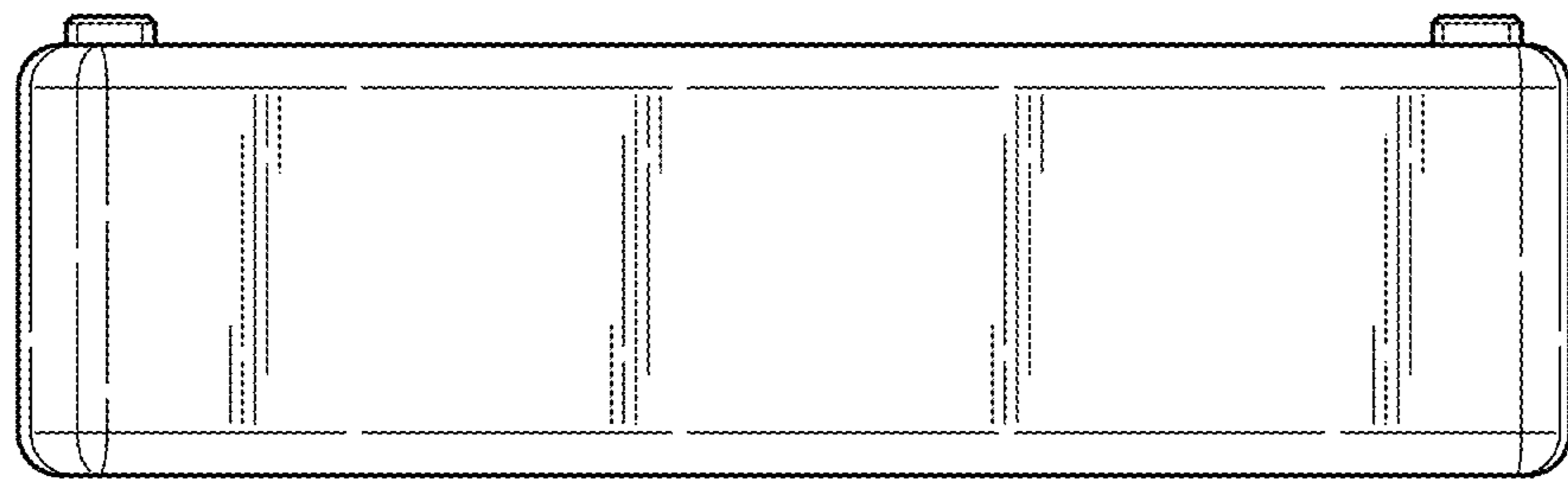

FIG. 3

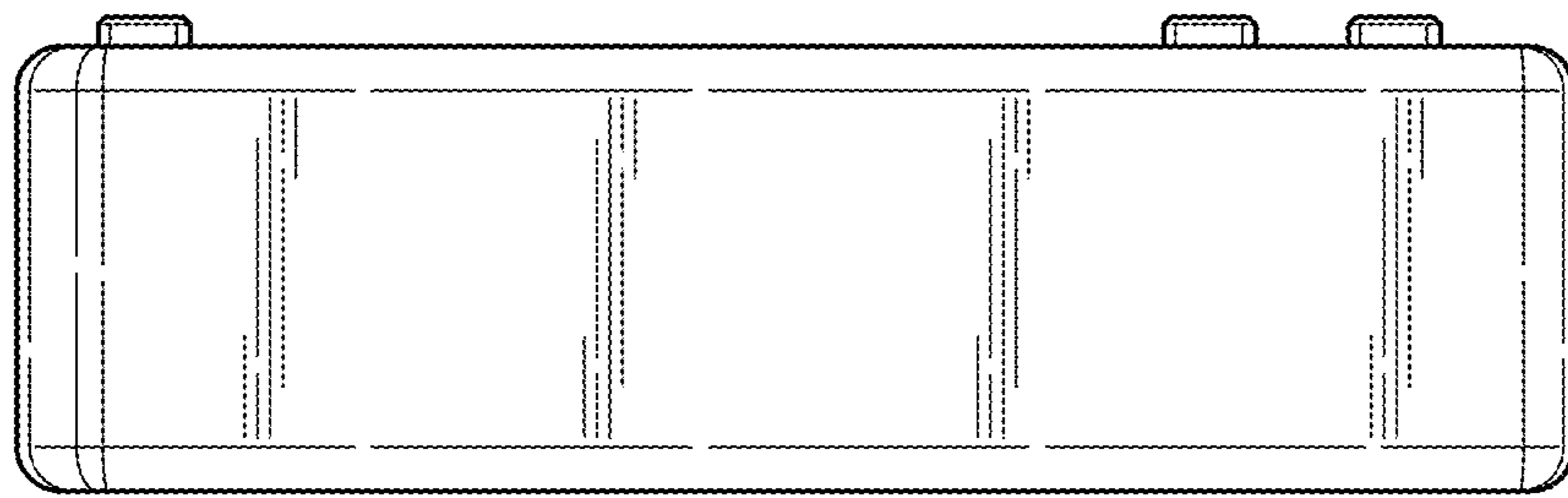

FIG. 4

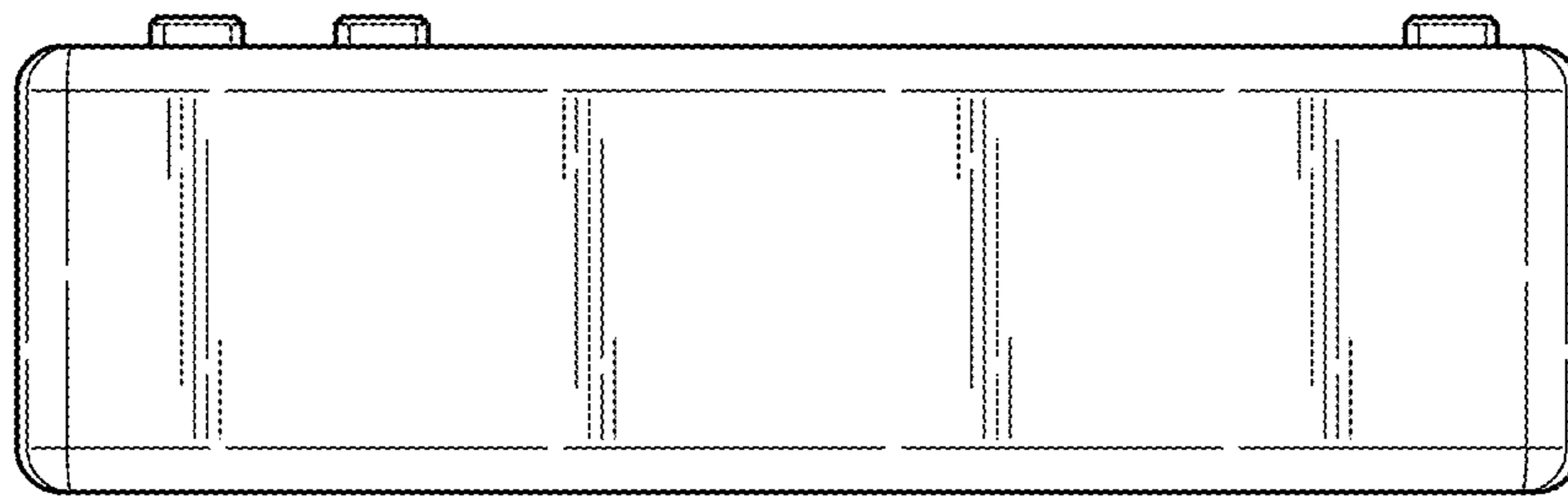

FIG. 5

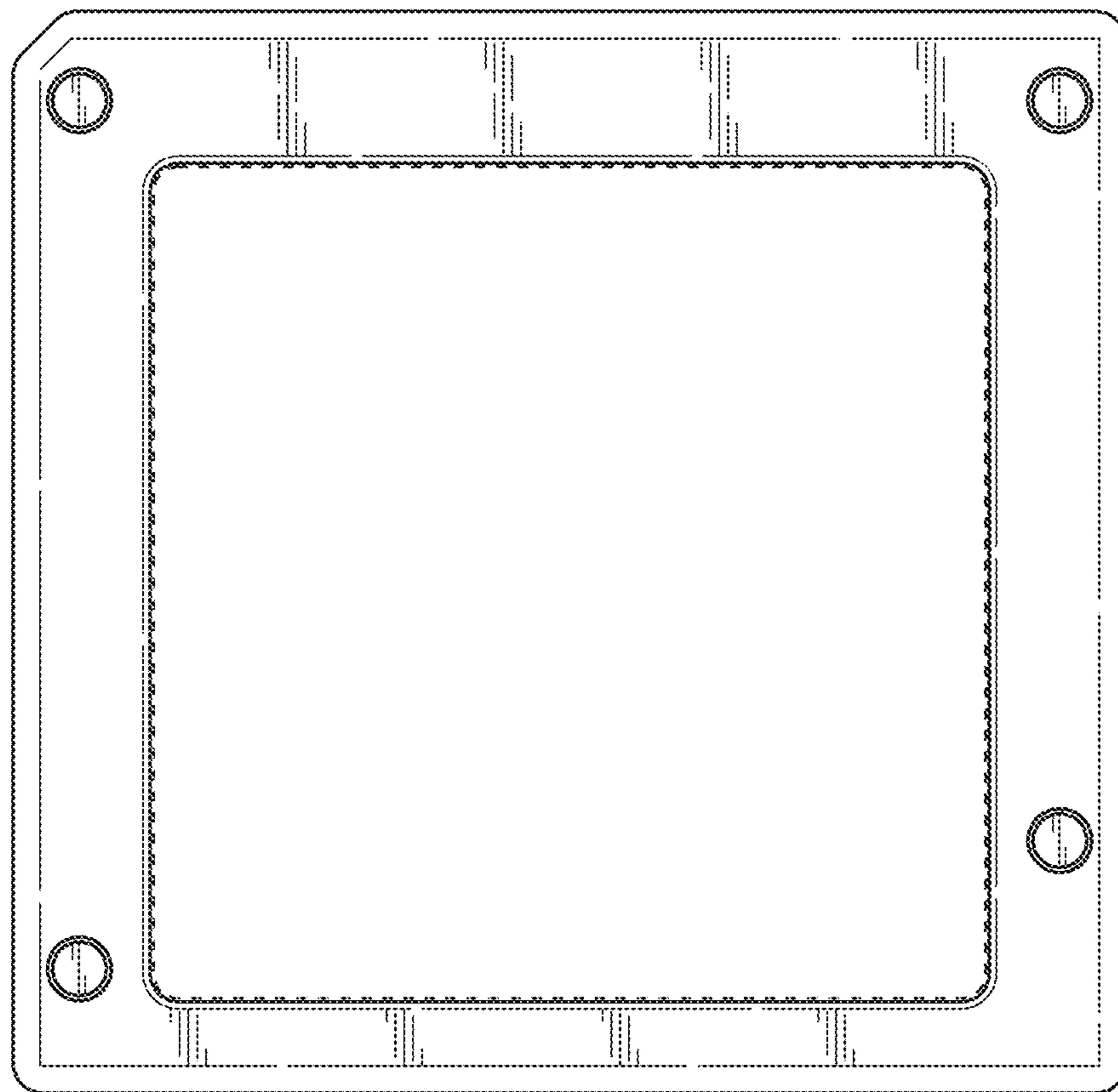

FIG. 6



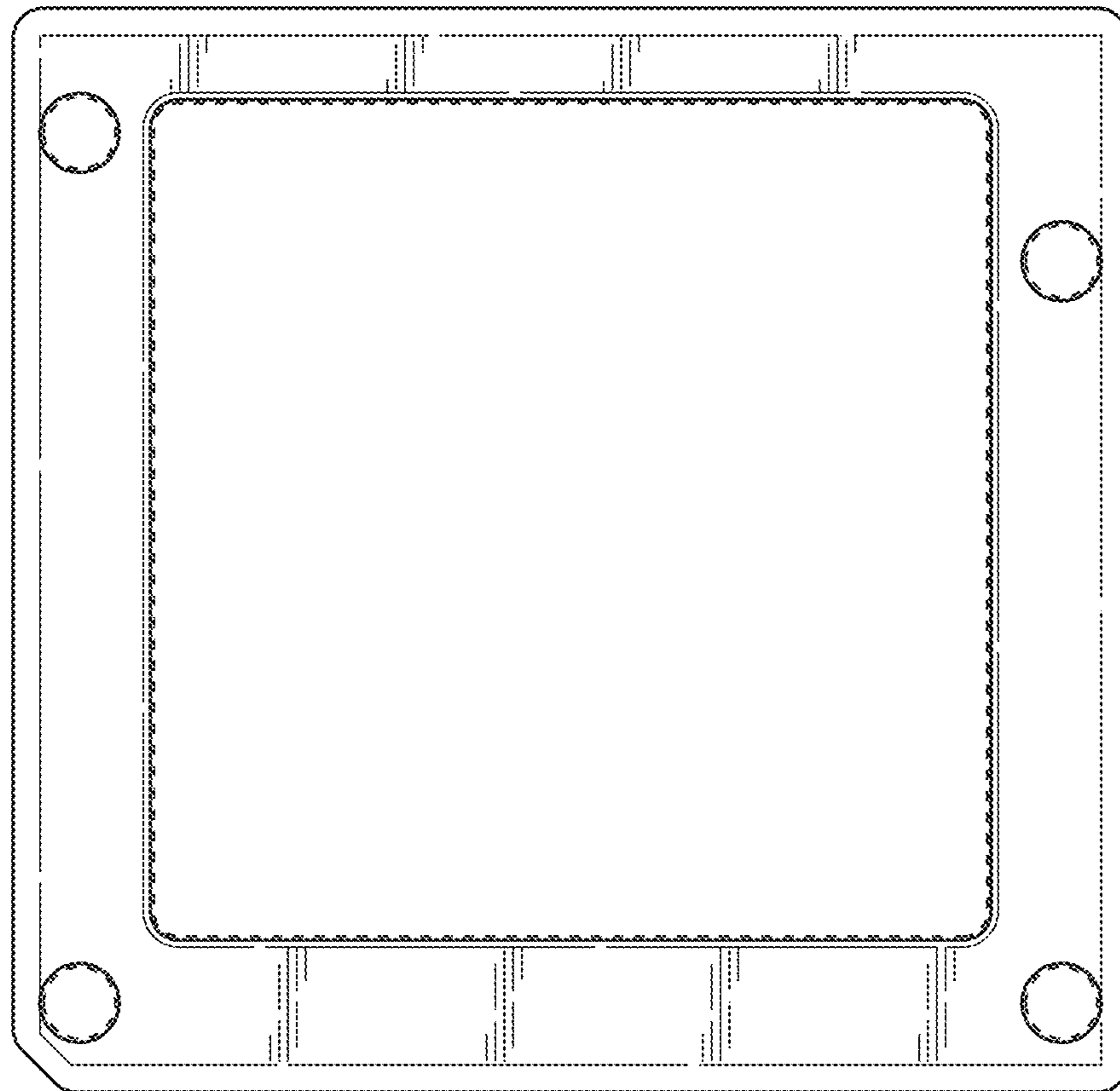

FIG. 7