

US00D970081S

(12) **United States Design Patent** (10) **Patent No.:** **US D970,081 S**
Kopitzke, IV (45) **Date of Patent:** **** Nov. 15, 2022**

(54) **LIGHT FIXTURE**

FOREIGN PATENT DOCUMENTS

- (71) Applicant: **DMF Inc.**, Carson, CA (US)
- (72) Inventor: **Frederick William Kopitzke, IV**, Long Beach, CA (US)
- (73) Assignee: **DMF, Inc.**, Carson, CA (US)
- (**) Term: **15 Years**
- (21) Appl. No.: **29/696,830**
- (22) Filed: **Jul. 1, 2019**

- CA 2243934 C 6/2002
- CA 2502637 A1 9/2005
- (Continued)

OTHER PUBLICATIONS

Maxim Lighting International, "Wafer LED 7" RD 3000K Wall/Flush Mount", undated.
(Continued)

Primary Examiner — Angela J Lee
(74) *Attorney, Agent, or Firm* — Smith Baluch LLP

Related U.S. Application Data

- (63) Continuation of application No. 29/648,937, filed on May 24, 2018, now Pat. No. Des. 877,957.
- (51) **LOC (13) Cl.** **26-05**
- (52) **U.S. Cl.**
USPC **D26/74**
- (58) **Field of Classification Search**
USPC D26/74, 72, 75, 76, 77, 78, 85, 88, 89, D26/118, 138, 141; 362/364, 365, 373, 362/145, 146, 147, 148, 150, 153, 153.1, 362/294, 296.01, 296.07, 296.08
CPC F21V 29/2262; F21V 7/06; F21V 21/044; F21V 21/047; F21V 29/2212; F21V 29/2225; F21V 29/2256; F21V 29/225; F21V 29/2268; F21Y 2111/002; F21S 8/02; F21S 8/026
See application file for complete search history.

(57) **CLAIM**

I claim the ornamental design for a light fixture, as shown and described.

DESCRIPTION

FIG. 1 is a top, front, left perspective view of an embodiment of the claimed design;
FIG. 2 is a bottom, front, left perspective view thereof;
FIG. 3 is a top plan view thereof;
FIG. 4 is a bottom plan view thereof;
FIG. 5 is a left side elevation view thereof;
FIG. 6 is a right side elevation view thereof;
FIG. 7 is a front elevation view thereof; and,
FIG. 8 is a rear elevation view thereof.
The ornamental design, which is claimed is shown in solid lines in the drawings. The broken lines in the drawings are for illustrative purposes only and form no part of the claimed design. Specifically, the dash-dash broken lines in the drawings are for the purpose of illustrating portions of the light fixture that form no part of the claimed design. The dash-dot broken lines in the drawings correspond to physical boundaries adjoining a bottom surface of the claimed design. The dash-dot broken lines, however, form no part of the claimed design.

(56) **References Cited**

U.S. PATENT DOCUMENTS

- 1,133,535 A 3/1915 Cain et al.
- 1,471,340 A 10/1923 Knight
- 1,856,356 A 5/1932 Owen
- 2,038,784 A 4/1936 Ghadiali
- 2,179,161 A 11/1939 Rambusch

(Continued)

1 Claim, 8 Drawing Sheets

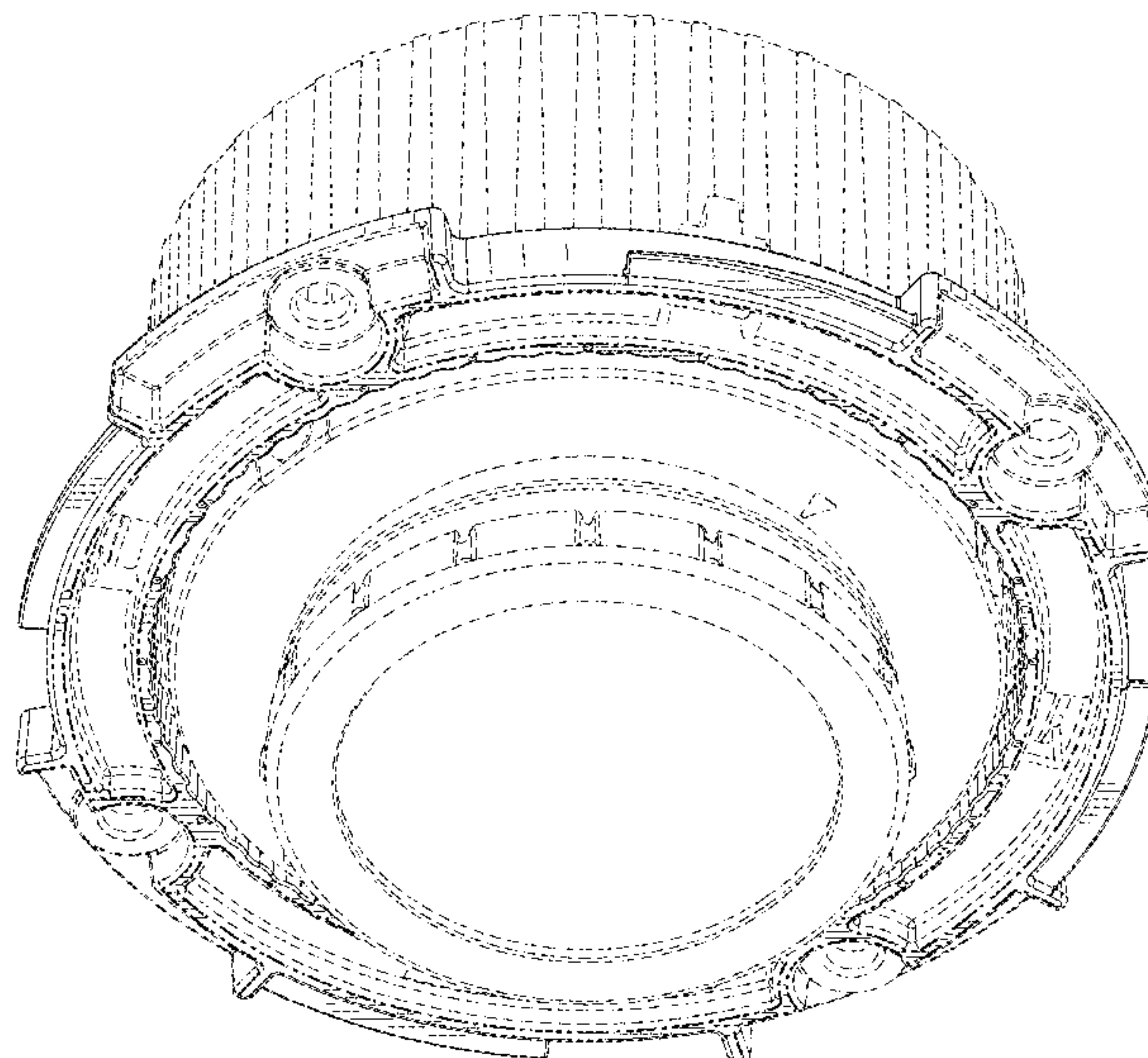

(56)

References Cited

U.S. PATENT DOCUMENTS

2,197,737	A	4/1940	Appleton	5,662,413	A	9/1997	Akiyama et al.
2,352,913	A	7/1944	Morrill	D386,277	S	11/1997	Lecluze
2,528,989	A	11/1950	Ammells	5,690,423	A	11/1997	Hentz et al.
2,597,595	A	5/1952	Ordas	D387,466	S	12/1997	Lecluze
2,642,246	A	6/1953	Larry	5,738,436	A	4/1998	Cummings et al.
2,670,919	A	3/1954	Vincent	5,778,625	A	7/1998	Druffel et al.
2,697,535	A	12/1954	Olson	5,836,678	A	11/1998	Wright et al.
2,758,810	A	8/1956	Good	5,942,726	A	8/1999	Reiker
D180,844	S	8/1957	Poliakoff	5,944,412	A	8/1999	Janos et al.
2,802,933	A	8/1957	Broadwin	5,957,573	A	9/1999	Wedekind et al.
2,998,512	A	8/1961	Duchene et al.	5,975,323	A	11/1999	Turan
3,023,920	A	3/1962	Cook et al.	6,030,102	A	2/2000	Gromotka
3,057,993	A	10/1962	Gellert	6,082,878	A	7/2000	Doubek et al.
3,104,087	A	9/1963	Joseph et al.	6,095,669	A	8/2000	Cho
3,214,126	A	10/1965	Roos	6,098,945	A	8/2000	Korcz
3,422,261	A	1/1969	McGinty	6,105,334	A	8/2000	Monson et al.
3,460,299	A	8/1969	Wilson	6,161,910	A	12/2000	Reisenauer et al.
3,650,046	A	3/1972	Skinner	6,170,685	B1	1/2001	Currier
3,675,807	A	7/1972	Lund et al.	6,174,076	B1	1/2001	Petrakis et al.
3,700,885	A	10/1972	Bobrick	6,176,599	B1	1/2001	Farzen
3,711,053	A	1/1973	Drake	6,267,491	B1	7/2001	Parrigin
D227,989	S	7/1973	Geisel	6,332,597	B1	12/2001	Korcz et al.
3,773,968	A	11/1973	Copp	6,350,043	B1	2/2002	Gloisten
3,812,342	A	5/1974	Mcnamara	6,350,046	B1	2/2002	Lau
3,836,766	A	9/1974	Auerbach	6,364,511	B1	4/2002	Cohen
3,874,035	A	4/1975	Schuplin	6,375,338	B1	4/2002	Cummings et al.
3,913,773	A	10/1975	Copp et al.	6,402,112	B1	6/2002	Thomas et al.
D245,905	S	9/1977	Taylor	D461,455	S	8/2002	Forbes
4,088,827	A	5/1978	Kohaut	D465,061	S	10/2002	Guthrie
4,154,218	A	5/1979	Hulet	6,461,016	B1	10/2002	Jamison et al.
4,154,219	A	5/1979	Gupta et al.	6,474,846	B1	11/2002	Kelmelis et al.
4,176,758	A	12/1979	Glick	6,491,413	B1	12/2002	Benesohn
4,280,169	A	7/1981	Allen	D468,697	S	1/2003	Straub, Jr.
4,399,497	A	8/1983	Druffel	D470,970	S	2/2003	Huang
4,450,512	A	5/1984	Kristofek	6,515,313	B1	2/2003	Ibbetson et al.
4,460,948	A	7/1984	Malola	6,521,833	B1	2/2003	DeFreitas
4,520,435	A	5/1985	Baldwin	D471,657	S	3/2003	Huang
4,539,629	A	9/1985	Poppenheimer	6,583,573	B2	6/2003	Bierman
4,601,145	A	7/1986	Wilcox	6,585,389	B2	7/2003	Bonazzi
4,667,840	A	5/1987	Lindsey	6,600,175	B1	7/2003	Baretz et al.
4,723,747	A	2/1988	Karp et al.	D478,872	S	8/2003	Heggem
4,729,080	A	3/1988	Fremont et al.	6,632,006	B1	10/2003	Rippel et al.
4,733,339	A	3/1988	Kelsall	6,657,236	B1	12/2003	Thibeault et al.
4,754,377	A	6/1988	Wenman	6,666,419	B1	12/2003	Vrame
4,770,311	A	9/1988	Wang	D488,583	S	4/2004	Benghozi
4,880,128	A	11/1989	Jorgensen	6,719,438	B2	4/2004	Sevack et al.
4,910,651	A	3/1990	Montanez	6,758,578	B1	7/2004	Chou
4,919,292	A	4/1990	Hsu	6,777,615	B1	8/2004	Gretz
4,929,187	A	5/1990	Hudson et al.	6,779,908	B1	8/2004	Ng
4,930,054	A	5/1990	Krebs	6,827,229	B2	12/2004	Dinh et al.
5,044,582	A	9/1991	Walters	6,827,471	B1	12/2004	Benghozi
D326,537	S	5/1992	Gattari	6,838,618	B2	1/2005	Newbold et al.
5,216,203	A	6/1993	Gower	6,906,352	B2	6/2005	Edmond et al.
5,222,800	A	6/1993	Chan et al.	D509,314	S	9/2005	Rashidi
5,239,132	A	8/1993	Bartow	6,948,829	B2	9/2005	Verdes et al.
5,250,269	A	10/1993	Langer et al.	6,958,497	B2	10/2005	Emerson et al.
5,266,050	A	11/1993	O'Neil et al.	6,964,501	B2	11/2005	Ryan
5,291,381	A	3/1994	Price	6,967,284	B1	11/2005	Gretz
5,303,894	A	4/1994	Deschamps et al.	D516,235	S	2/2006	Rashidi
5,382,752	A	1/1995	Reyhan et al.	7,025,476	B2	4/2006	Leadford
5,420,376	A	5/1995	Rajecki et al.	7,025,477	B2	4/2006	Blessing
5,444,606	A	8/1995	Barnes et al.	7,064,269	B2	6/2006	Smith
5,465,199	A	11/1995	Bray et al.	D528,673	S	9/2006	Maxik et al.
D365,165	S	12/1995	Stultz	7,102,172	B2	9/2006	Lynch
5,505,419	A	4/1996	Gabrius	D531,740	S	11/2006	Maxik
5,544,870	A	8/1996	Kelly et al.	D532,532	S	11/2006	Maxik
5,562,343	A	10/1996	Chan et al.	7,148,420	B1	12/2006	Johnson et al.
5,571,993	A	11/1996	Jones et al.	7,148,632	B2	12/2006	Berman et al.
5,580,158	A	12/1996	Aubrey et al.	7,152,985	B2	12/2006	Benitez et al.
5,588,737	A	12/1996	Kusmer	7,154,040	B1	12/2006	Tompkins
D377,843	S	2/1997	Schering	7,170,015	B1	1/2007	Roesch et al.
5,603,424	A	2/1997	Bordwell et al.	D536,349	S	2/2007	Humber et al.
5,609,408	A	3/1997	Targetti	D537,039	S	2/2007	Pincek
5,613,338	A	3/1997	Esposito	7,181,378	B2	2/2007	Benitez et al.
D381,111	S	7/1997	Lecluze	D539,229	S	3/2007	Murphey
				7,186,008	B2	3/2007	Patti
				7,190,126	B1	3/2007	Paton
				7,211,833	B2	5/2007	Slater, Jr. et al.
				7,213,940	B1	5/2007	Van De Ven et al.

(56)

References Cited

U.S. PATENT DOCUMENTS

7,234,674 B2	6/2007	Rippel et al.	7,871,184 B2	1/2011	Peng
D547,889 S	7/2007	Huang	7,874,539 B2	1/2011	Wright et al.
D552,969 S	10/2007	Bobrowski et al.	7,874,703 B2	1/2011	Shastry et al.
D553,267 S	10/2007	Yuen	7,874,709 B1	1/2011	Beadle
D555,106 S	11/2007	Pape et al.	D632,839 S	2/2011	Kim et al.
D556,144 S	11/2007	Dinh	D633,224 S	2/2011	Lee
7,297,870 B1	11/2007	Sartini	7,909,487 B1	3/2011	Venetucci et al.
7,312,474 B2	12/2007	Emerson et al.	D636,117 S	4/2011	Kim et al.
7,320,536 B2	1/2008	Petrakis et al.	D636,118 S	4/2011	Kim et al.
D561,372 S	2/2008	Yan	D636,903 S	4/2011	Torenbeek
D561,373 S	2/2008	Yan	D637,339 S	5/2011	Hasan et al.
7,335,920 B2	2/2008	Denbaars et al.	D637,340 S	5/2011	Hasan et al.
D563,896 S	3/2008	Greenslate	7,950,832 B2	5/2011	Tanaka et al.
7,347,580 B2	3/2008	Blackman et al.	D639,499 S	6/2011	Choi et al.
D570,012 S	5/2008	Huang	D640,819 S	6/2011	Pan
7,374,308 B2	5/2008	Sevack et al.	7,956,546 B2	6/2011	Hasnain
D570,504 S	6/2008	Maxik et al.	7,959,332 B2	6/2011	Tickner et al.
D570,505 S	6/2008	Maxik et al.	7,967,480 B2	6/2011	Pickard et al.
7,399,104 B2	7/2008	Rappaport	D642,317 S	7/2011	Rashidi
7,413,156 B1	8/2008	Cho	7,972,035 B2	7/2011	Boyer
7,429,025 B1	9/2008	Gretz	7,972,043 B2	7/2011	Schutte
D578,677 S	10/2008	Huang	D642,536 S	8/2011	Robinson
7,431,482 B1	10/2008	Morgan et al.	D643,970 S	8/2011	Kim et al.
7,432,440 B2	10/2008	Hull et al.	7,993,037 B1	8/2011	Buse
7,442,883 B2	10/2008	Jolly et al.	8,002,425 B2	8/2011	Russo et al.
7,446,345 B2	11/2008	Emerson et al.	D646,011 S	9/2011	Rashidi
7,470,048 B2	12/2008	Wu	8,013,243 B2	9/2011	Korcz et al.
7,473,005 B2	1/2009	O'Brien	8,038,113 B2	10/2011	Fryzek et al.
D586,497 S	2/2009	Wu et al.	D648,476 S	11/2011	Choi et al.
7,488,097 B2	2/2009	Reisenauer et al.	D648,477 S	11/2011	Kim et al.
7,494,258 B2	2/2009	McNaught	D650,115 S	12/2011	Kim et al.
7,503,145 B2	3/2009	Newbold et al.	8,070,328 B1	12/2011	Knoble et al.
7,524,089 B2	4/2009	Park	8,096,670 B2	1/2012	Trott
D591,894 S	5/2009	Flank	D654,205 S	2/2012	Rashidi
7,534,989 B2	5/2009	Suehara et al.	D655,436 S	3/2012	Johnson
D596,154 S	7/2009	Rivkin	D656,262 S	3/2012	Yoshinobu et al.
7,566,154 B2	7/2009	Gloisten et al.	D656,263 S	3/2012	Ogawa et al.
D599,040 S	8/2009	Alexander et al.	8,142,057 B2	3/2012	Roos et al.
D600,836 S	9/2009	Hanley et al.	8,152,334 B2	4/2012	Krogman
7,588,359 B2	9/2009	Coushaine et al.	D658,788 S	5/2012	Dudik et al.
7,592,583 B2	9/2009	Page et al.	D658,802 S	5/2012	Chen
D606,696 S	12/2009	Chen et al.	D659,862 S	5/2012	Tsai
7,625,105 B1	12/2009	Johnson	D659,879 S	5/2012	Rashidi
7,628,513 B2	12/2009	Chiu	D660,814 S	5/2012	Wilson
7,651,238 B2	1/2010	O'Brien	8,182,116 B2	5/2012	Zhang et al.
7,654,705 B2	2/2010	Czech et al.	8,201,968 B2	6/2012	Maxik et al.
D611,650 S	3/2010	Broekhoff	D663,058 S	7/2012	Pan
7,670,021 B2	3/2010	Chou	D663,466 S	7/2012	Rashidi
7,673,841 B2	3/2010	Wronski	D664,274 S	7/2012	de Visser et al.
7,677,766 B2	3/2010	Boyer	D664,705 S	7/2012	Kong et al.
D613,444 S	4/2010	Rashidi	8,215,805 B2	7/2012	Cogliano et al.
7,692,182 B2	4/2010	Bergmann et al.	8,220,970 B1	7/2012	Khazi et al.
7,704,763 B2	4/2010	Fujii et al.	8,226,270 B2	7/2012	Yamamoto et al.
D616,118 S	5/2010	Thomas et al.	8,235,549 B2	8/2012	Gingrich, III et al.
7,712,922 B2	5/2010	Hacker et al.	8,238,050 B2	8/2012	Minano et al.
7,722,208 B1	5/2010	Dupre et al.	8,240,630 B2	8/2012	Wronski
7,722,227 B2	5/2010	Zhang et al.	D667,155 S	9/2012	Rashidi
7,735,795 B2	6/2010	Wronski	8,262,255 B1	9/2012	Rashidi
7,735,798 B2	6/2010	Kojima	D668,372 S	10/2012	Renshaw et al.
7,748,887 B2	7/2010	Zampini, II et al.	D668,809 S	10/2012	Rashidi
7,766,518 B2	8/2010	Piegras et al.	D669,198 S	10/2012	Qui
7,769,192 B2	8/2010	Takagi et al.	D669,199 S	10/2012	Chuang
7,771,082 B2	8/2010	Peng	D669,620 S	10/2012	Rashidi
7,771,094 B2	8/2010	Goode	8,277,090 B2	10/2012	Fryzek et al.
7,784,754 B2	8/2010	Nevers et al.	D671,668 S	11/2012	Rowlette, Jr. et al.
D624,691 S	9/2010	Zhang et al.	8,308,322 B2	11/2012	Santiago et al.
D624,692 S	9/2010	Mackin et al.	D672,899 S	12/2012	Ven et al.
D625,847 S	10/2010	Maglica	D673,869 S	1/2013	Yu
D625,876 S	10/2010	Chen et al.	D676,263 S	2/2013	Birke
D627,507 S	11/2010	Lai et al.	D676,814 S	2/2013	Paul
D627,727 S	11/2010	Alexander et al.	8,376,593 B2	2/2013	Bazydola et al.
7,828,465 B2	11/2010	Roberge et al.	D677,417 S	3/2013	Rashidi
D629,366 S	12/2010	Ericson et al.	D677,634 S	3/2013	Korcz et al.
7,845,393 B2	12/2010	Kao et al.	D679,044 S	3/2013	Jeswani et al.
7,857,275 B2	12/2010	de la Borbolla	D679,047 S	3/2013	Tickner et al.
			8,403,533 B1	3/2013	Paulsel
			8,403,541 B1	3/2013	Rashidi
			8,405,947 B1	3/2013	Green et al.
			D681,259 S	4/2013	Kong

(56)

References Cited

U.S. PATENT DOCUMENTS

8,408,759 B1	4/2013	Rashidi	D722,978 S	2/2015	Hagarty
D682,459 S	5/2013	Gordin et al.	8,950,898 B2	2/2015	Catalano
D683,063 S	5/2013	Lopez et al.	D723,781 S	3/2015	Miner
D683,890 S	6/2013	Lopez et al.	D723,783 S	3/2015	Miner
D684,269 S	6/2013	Wang et al.	D725,359 S	3/2015	Miner
D684,287 S	6/2013	Rashidi	8,967,575 B1	3/2015	Gretz
D684,719 S	6/2013	Rashidi	D726,363 S	4/2015	Danesh
D685,118 S	6/2013	Rashidi	D726,949 S	4/2015	Redfern
D685,120 S	6/2013	Rashidi	D728,129 S	4/2015	Kreuzbichler
8,454,204 B1	6/2013	Chang et al.	9,004,435 B2	4/2015	Wronski
D685,507 S	7/2013	Sun	9,039,254 B2	5/2015	Danesh
D687,586 S	8/2013	Rashidi	D731,689 S	6/2015	Bernard et al.
D687,587 S	8/2013	Rashidi	9,062,866 B1	6/2015	Christ et al.
D687,588 S	8/2013	Rashidi	9,065,264 B2	6/2015	Cooper et al.
D687,980 S	8/2013	Gravely et al.	9,068,719 B2	6/2015	Van De Ven et al.
D688,405 S	8/2013	Kim et al.	9,068,722 B2	6/2015	Wronski et al.
8,506,127 B2	8/2013	Russello et al.	D734,525 S	7/2015	Gordin et al.
8,506,134 B2	8/2013	Wilson et al.	D735,012 S	7/2015	Cowie
D690,049 S	9/2013	Rashidi	D735,142 S	7/2015	Hagarty
D690,053 S	9/2013	Zhang et al.	9,078,299 B2	7/2015	Ashdown
D690,864 S	10/2013	Rashidi	D735,933 S	8/2015	Campagna
D690,865 S	10/2013	Rashidi	9,109,760 B2	8/2015	Shum et al.
D690,866 S	10/2013	Rashidi	9,109,783 B1	8/2015	Davis et al.
D691,314 S	10/2013	Rashidi	D739,355 S	9/2015	D'Aubeterre
D691,315 S	10/2013	Samson	D739,590 S	9/2015	Redfern
D691,763 S	10/2013	Hand et al.	9,140,441 B2	9/2015	Goelz et al.
8,550,669 B2	10/2013	Macwan et al.	D741,538 S	10/2015	Ghasabi
D693,043 S	11/2013	Schmalfuss et al.	9,151,457 B2	10/2015	Pickard et al.
D693,517 S	11/2013	Davis	9,151,477 B2	10/2015	Pickard et al.
D694,456 S	11/2013	Rowlette, Jr. et al.	D742,325 S	11/2015	Leung
8,573,816 B2	11/2013	Negley et al.	D743,079 S	11/2015	Adair
D695,441 S	12/2013	Lui et al.	D744,723 S	12/2015	Yoo
D695,941 S	12/2013	Rashidi	9,217,560 B2	12/2015	Harbers et al.
D696,446 S	12/2013	Huh	9,222,661 B2	12/2015	Kim et al.
D696,447 S	12/2013	Huh	9,239,131 B1	1/2016	Wronski et al.
D696,448 S	12/2013	Huh	D750,317 S	2/2016	Lui et al.
8,602,601 B2	12/2013	Khazi et al.	9,285,103 B2	3/2016	Van De Ven et al.
D698,067 S	1/2014	Rashidi	9,291,319 B2	3/2016	Kathawate et al.
D698,068 S	1/2014	Rashidi	9,301,362 B2	3/2016	Dohn et al.
8,622,361 B2	1/2014	Wronski	D754,078 S	4/2016	Baldwin et al.
8,632,040 B2	1/2014	Mass et al.	D754,079 S	4/2016	Baldwin et al.
D698,985 S	2/2014	Lopez et al.	D754,605 S	4/2016	McMillan
D699,384 S	2/2014	Rashidi	9,303,812 B2	4/2016	Green et al.
D699,687 S	2/2014	Baldwin et al.	9,310,038 B2	4/2016	Athalye
D700,387 S	2/2014	Snell	9,310,052 B1	4/2016	Shum
8,641,243 B1	2/2014	Rashidi	9,322,543 B2	4/2016	Hussell et al.
8,659,034 B2	2/2014	Baretz et al.	9,347,655 B2	5/2016	Boomgaarden et al.
D700,737 S	3/2014	Campagna	9,366,418 B2	6/2016	Gifford
D700,991 S	3/2014	Johnson et al.	9,371,966 B2	6/2016	Rowlette, Jr. et al.
D701,175 S	3/2014	Baldwin et al.	D762,181 S	7/2016	Lin
D701,466 S	3/2014	Clifford et al.	9,395,051 B2	7/2016	Hussell et al.
8,672,518 B2	3/2014	Boomgaarden et al.	D762,906 S	8/2016	Jeswani et al.
D702,867 S	4/2014	Kim et al.	D764,079 S	8/2016	Wu
D703,843 S	4/2014	Cheng	9,417,506 B1	8/2016	Tirosh
8,684,569 B2	4/2014	Pickard et al.	9,423,110 B1	8/2016	Newton et al.
8,696,158 B2	4/2014	Santiago et al.	D766,185 S	9/2016	Hagarty
D705,472 S	5/2014	Huh	D767,199 S	9/2016	Wronski et al.
D705,481 S	5/2014	Zhang et al.	9,447,917 B1	9/2016	Wronski et al.
8,727,582 B2	5/2014	Brown et al.	9,447,953 B2	9/2016	Lawlor
D708,381 S	7/2014	Rashidi	D768,325 S	10/2016	Xu
8,777,449 B2	7/2014	Ven et al.	D768,326 S	10/2016	Guzzini
D710,529 S	8/2014	Lopez et al.	D769,501 S	10/2016	Jeswani et al.
8,801,217 B2	8/2014	Oehle et al.	D770,065 S	10/2016	Tittle
8,820,985 B1	9/2014	Tam et al.	D770,076 S	10/2016	Li et al.
8,833,013 B2	9/2014	Harman	D770,084 S	10/2016	Salomon
8,845,144 B1	9/2014	Davies et al.	9,476,552 B2	10/2016	Myers et al.
D714,989 S	10/2014	Rowlette, Jr. et al.	D770,673 S	11/2016	Hasan et al.
8,870,426 B2	10/2014	Biebl et al.	9,488,324 B2	11/2016	Shum et al.
8,888,332 B2	11/2014	Martis et al.	D774,676 S	12/2016	Ng
8,890,414 B2	11/2014	Rowlette, Jr. et al.	D776,324 S	1/2017	Gierl et al.
D721,845 S	1/2015	Lui et al.	D777,967 S	1/2017	Redfern
8,926,133 B2	1/2015	Booth	9,534,751 B2	1/2017	Maglica et al.
8,939,418 B2	1/2015	Green et al.	D778,241 S	2/2017	Holbrook et al.
D722,296 S	2/2015	Taylor	D778,484 S	2/2017	Guzzini
D722,977 S	2/2015	Hagarty	D779,100 S	2/2017	Redfern
			D779,105 S	2/2017	Krueckeberg et al.
			D779,711 S	2/2017	Salomon
			9,581,302 B2	2/2017	Danesh
			9,599,315 B1	3/2017	Harpenau et al.

(56)

References Cited

U.S. PATENT DOCUMENTS

9,605,842 B1	3/2017	Davis	10,609,785 B1	3/2020	Fardadi et al.
9,605,910 B2	3/2017	Swedberg et al.	D880,733 S	4/2020	Lo et al.
D785,228 S	4/2017	Guzzini	D883,562 S	5/2020	Hu
D785,852 S	5/2017	Doust	D885,648 S	5/2020	Zeng
D786,472 S	5/2017	Redfern	D885,649 S	5/2020	McLaughlin, III et al.
D786,473 S	5/2017	Dean	10,663,127 B2	5/2020	Danesh et al.
D786,474 S	5/2017	Fujisawa	10,663,153 B2	5/2020	Nikooyan et al.
D788,330 S	5/2017	Johnson et al.	D888,313 S	6/2020	Xie et al.
D790,102 S	6/2017	Guzzini	10,683,994 B2	6/2020	Wronski et al.
9,673,597 B2	6/2017	Lee	10,684,003 B2	6/2020	Wronski et al.
9,689,541 B2	6/2017	Wronski	D890,410 S	7/2020	Stanford et al.
D791,709 S	7/2017	Holton	10,704,745 B2	7/2020	Sherry et al.
D791,711 S	7/2017	Holton	10,753,558 B2 *	8/2020	Danesh F21V 23/003
D791,712 S	7/2017	Holton	10,808,917 B2	10/2020	Harris et al.
9,696,021 B2	7/2017	Wronski	10,816,148 B2	10/2020	Danesh
9,702,516 B1	7/2017	Vasquez et al.	D901,398 S	11/2020	Danesh et al.
D795,820 S	8/2017	Wengreen	D901,745 S	11/2020	Yang
9,732,904 B1	8/2017	Wronski	D902,871 S	11/2020	Danesh et al.
9,732,947 B1	8/2017	Christ et al.	D903,605 S	12/2020	Danesh et al.
9,739,464 B2	8/2017	Wronski	D905,327 S	12/2020	Williams et al.
D799,105 S	10/2017	Eder et al.	D907,284 S	1/2021	Danesh et al.
D800,957 S	10/2017	Eder et al.	D910,223 S *	2/2021	Cohen D26/74
9,791,111 B1	10/2017	Huang et al.	10,975,570 B2 *	4/2021	Shen F21S 8/043
9,797,562 B2	10/2017	Dabiet et al.	10,982,829 B2	4/2021	Danesh
9,803,839 B2	10/2017	Visser et al.	11,022,259 B2	6/2021	Bailey et al.
D805,660 S	12/2017	Creasman et al.	11,028,982 B2	6/2021	Danesh
9,854,642 B2	12/2017	Kashani	11,047,538 B2	6/2021	Danesh et al.
D809,176 S	1/2018	Partington	D924,467 S	7/2021	Danesh et al.
9,860,961 B2	1/2018	Chemel et al.	D925,109 S	7/2021	Danesh et al.
9,863,619 B2	1/2018	Mak	11,060,705 B1	7/2021	Danesh et al.
D809,465 S	2/2018	Keirstead	11,067,231 B2	7/2021	Lotfi et al.
9,903,569 B2	2/2018	O'Brien et al.	D927,430 S	8/2021	Cohen et al.
9,945,548 B2	4/2018	Williams et al.	11,085,597 B2	8/2021	Danesh
9,964,266 B2	5/2018	Danesh	11,118,768 B2	9/2021	Danesh
D820,494 S *	6/2018	Cohen D26/74	D939,134 S	12/2021	Danesh et al.
D821,615 S	6/2018	Trice	11,231,154 B2	1/2022	Kopitzke et al.
D821,627 S	6/2018	Ko	D944,212 S	2/2022	Peng et al.
9,995,441 B2	6/2018	Power et al.	11,242,983 B2	2/2022	Danesh
D822,505 S	7/2018	Gibson et al.	11,255,497 B2	2/2022	Danesh
D824,089 S	7/2018	Dupras	2002/0172047 A1	11/2002	Ashley
D824,494 S	7/2018	Martins et al.	2003/0006353 A1	1/2003	Dinh et al.
D824,566 S	7/2018	Santoro et al.	2003/0016532 A1	1/2003	Reed
D825,829 S	8/2018	Guo	2003/0021104 A1	1/2003	Tsao
10,041,638 B2	8/2018	Vasquez et al.	2003/0161153 A1	8/2003	Patti
10,054,274 B2	8/2018	Athalye et al.	2004/0001337 A1	1/2004	Defouw et al.
D827,903 S	9/2018	Wu	2004/0120141 A1	6/2004	Beadle
10,072,805 B2	9/2018	Bailey	2004/0156199 A1	8/2004	Rivas et al.
D832,218 S	10/2018	Wronski et al.	2005/0078474 A1	4/2005	Whitfield
D833,977 S	11/2018	Danesh et al.	2005/0121215 A1	6/2005	Halbert
10,125,959 B2	11/2018	Cohen	2005/0225966 A1	10/2005	Hartmann et al.
10,139,059 B2 *	11/2018	Danesh F21V 21/048	2005/0227536 A1	10/2005	Gamache et al.
D836,976 S	1/2019	Reese et al.	2005/0231962 A1	10/2005	Koba et al.
D843,642 S	3/2019	Mathews et al.	2005/0237746 A1	10/2005	Yiu
10,244,607 B1	3/2019	Kashani	2006/0005988 A1	1/2006	Jorgensen
D847,414 S	4/2019	Danesh et al.	2006/0158873 A1	7/2006	Newbold et al.
D847,415 S	4/2019	Danesh et al.	2006/0198126 A1	9/2006	Jones
10,247,390 B1	4/2019	Kopitzke et al.	2006/0215408 A1	9/2006	Lee
D848,375 S	5/2019	Danesh et al.	2006/0221620 A1	10/2006	Thomas
10,281,131 B2	5/2019	Cohen	2006/0237601 A1	10/2006	Rinderer
10,295,163 B1	5/2019	Cohen	2006/0243877 A1	11/2006	Rippel
D850,695 S	6/2019	Dabiet et al.	2006/0250788 A1	11/2006	Hodge et al.
D851,046 S	6/2019	Peng et al.	2006/0262536 A1	11/2006	Nevers
10,408,395 B2	9/2019	Danesh	2006/0262545 A1	11/2006	Pieprgras et al.
10,408,396 B2	9/2019	Wronski et al.	2007/0012847 A1	1/2007	Tai
10,408,436 B2	9/2019	Wronski et al.	2007/0035951 A1	2/2007	Tseng
D863,661 S	10/2019	Tian et al.	2007/0121328 A1	5/2007	Mondloch et al.
D864,468 S	10/2019	Behnke et al.	2007/0131827 A1	6/2007	Nevers et al.
D864,877 S	10/2019	Danesh	2007/0185675 A1	8/2007	Papamichael et al.
D864,885 S	10/2019	Kobayashi et al.	2007/0200039 A1	8/2007	Petak
D867,653 S	11/2019	Gorman	2007/0206374 A1	9/2007	Petrakis et al.
10,488,000 B2	11/2019	Danesh et al.	2008/0002414 A1	1/2008	Miletich et al.
10,551,044 B2	2/2020	Peng et al.	2008/0019138 A1	1/2008	Otte et al.
10,563,850 B2	2/2020	Danesh	2008/0068847 A1	3/2008	Bedard
D877,957 S *	3/2020	Kopitzke, IV D26/74	2008/0112168 A1	5/2008	Pickard et al.
10,591,120 B2	3/2020	Bailey et al.	2008/0112170 A1	5/2008	Trott
			2008/0112171 A1	5/2008	Patti et al.
			2008/0130308 A1	6/2008	Behr et al.
			2008/0137347 A1	6/2008	Trott et al.
			2008/0165545 A1	7/2008	O'Brien

(56)

References Cited

U.S. PATENT DOCUMENTS

2008/0170404 A1	7/2008	Steer et al.	2013/0010476 A1	1/2013	Pickard et al.	
2008/0186718 A1	8/2008	Magisano et al.	2013/0016864 A1	1/2013	Ivey et al.	
2008/0224008 A1	9/2008	Dal Ponte et al.	2013/0033872 A1	2/2013	Randolph et al.	
2008/0232116 A1	9/2008	Kim	2013/0050994 A1*	2/2013	Pieper	F21V 7/00 362/147
2008/0247181 A1	10/2008	Dixon	2013/0051012 A1*	2/2013	Oehle	F21V 17/12 362/235
2008/0285271 A1	11/2008	Roberge et al.	2013/0077307 A1	3/2013	Yamamoto	
2009/0003009 A1	1/2009	Tessnow et al.	2013/0083529 A1	4/2013	Gifford	
2009/0034261 A1	2/2009	Grove	2013/0141913 A1	6/2013	Sachsenweger	
2009/0080189 A1	3/2009	Wegner	2013/0155681 A1	6/2013	Nall et al.	
2009/0086484 A1	4/2009	Johnson	2013/0163254 A1	6/2013	Chang et al.	
2009/0097262 A1	4/2009	Zhang et al.	2013/0170232 A1	7/2013	Park et al.	
2009/0135613 A1	5/2009	Peng	2013/0170233 A1	7/2013	Nezu et al.	
2009/0141500 A1	6/2009	Peng	2013/0201699 A1	8/2013	Kato et al.	
2009/0141506 A1	6/2009	Lan et al.	2013/0227908 A1	9/2013	Gulbrandsen et al.	
2009/0141508 A1	6/2009	Peng	2013/0258677 A1	10/2013	Fryzek et al.	
2009/0147517 A1	6/2009	Li	2013/0265750 A1	10/2013	Pickard et al.	
2009/0161356 A1	6/2009	Negley et al.	2013/0271989 A1	10/2013	Hussell et al.	
2009/0237924 A1	9/2009	Ladewig	2013/0294084 A1	11/2013	Kathawate et al.	
2009/0280695 A1	11/2009	Sekela et al.	2013/0301252 A1	11/2013	Hussell et al.	
2009/0283292 A1	11/2009	Lehr	2013/0322062 A1	12/2013	Danesh	
2009/0290343 A1	11/2009	Brown et al.	2013/0322084 A1	12/2013	Ebisawa	
2010/0002320 A1	1/2010	Minano et al.	2013/0335980 A1	12/2013	Nakasuji et al.	
2010/0014282 A1	1/2010	Danesh	2014/0029262 A1	1/2014	Maxik et al.	
2010/0033095 A1	2/2010	Sadwick	2014/0036497 A1	2/2014	Hussell et al.	
2010/0061108 A1	3/2010	Zhang et al.	2014/0049957 A1	2/2014	Goelz et al.	
2010/0067226 A1	3/2010	Higuchi et al.	2014/0063776 A1	3/2014	Clark et al.	
2010/0110690 A1	5/2010	Hsu et al.	2014/0071679 A1	3/2014	Booth	
2010/0110698 A1	5/2010	Harwood et al.	2014/0071687 A1	3/2014	Tickner et al.	
2010/0110699 A1	5/2010	Chou	2014/0140490 A1	5/2014	Roberts et al.	
2010/0148673 A1	6/2010	Stewart et al.	2014/0063818 A1	6/2014	Randolph et al.	
2010/0149822 A1	6/2010	Cogliano et al.	2014/0233246 A1	8/2014	Lafreniere et al.	
2010/0155497 A1	6/2010	Hagaman	2014/0254177 A1	9/2014	Danesh	
2010/0165643 A1	7/2010	Russo et al.	2014/0268836 A1	9/2014	Thompson	
2010/0244709 A1	9/2010	Steiner et al.	2014/0268869 A1	9/2014	Blessitt et al.	
2010/0246172 A1	9/2010	Liu	2014/0299730 A1	10/2014	Green et al.	
2010/0259919 A1	10/2010	Khazi et al.	2014/0313775 A1	10/2014	Myers et al.	
2010/0270903 A1	10/2010	Jao et al.	2014/0321122 A1	10/2014	Domagala et al.	
2010/0277905 A1	11/2010	Janik et al.	2014/0347848 A1	11/2014	Pisavadia et al.	
2010/0284185 A1	11/2010	Ngai	2015/0009676 A1	1/2015	Danesh	
2010/0302778 A1	12/2010	Dabiet et al.	2015/0029732 A1	1/2015	Hatch	
2010/0328956 A1	12/2010	Zhang	2015/0078008 A1	3/2015	He	
2011/0043040 A1	2/2011	Porter et al.	2015/0085495 A1	3/2015	Seki	
2011/0063831 A1	3/2011	Cook	2015/0085500 A1	3/2015	Cooper et al.	
2011/0068687 A1	3/2011	Takahasi et al.	2015/0092449 A1	4/2015	Demuyne et al.	
2011/0069499 A1	3/2011	Trott et al.	2015/0131301 A1	5/2015	Ho	
2011/0080750 A1	4/2011	Jones et al.	2015/0138779 A1	5/2015	Livesay et al.	
2011/0116276 A1	5/2011	Okamura et al.	2015/0153635 A1*	6/2015	Chen	F21V 29/80 362/287
2011/0121756 A1	5/2011	Thomas et al.	2015/0184837 A1	7/2015	Zhang et al.	
2011/0134634 A1	6/2011	Gingrich, III et al.	2015/0198324 A1	7/2015	O'Brien et al.	
2011/0134651 A1	6/2011	Berman	2015/0219317 A1	8/2015	Gatof et al.	
2011/0140633 A1	6/2011	Archenhold	2015/0233556 A1*	8/2015	Danesh	F21V 21/048 362/365
2011/0170294 A1	7/2011	Mier-Langner et al.	2015/0241039 A1	8/2015	Fryzek	
2011/0194299 A1	8/2011	Crooks et al.	2015/0263497 A1	9/2015	Korcz et al.	
2011/0216534 A1	9/2011	Tickner et al.	2015/0276185 A1	10/2015	Bailey et al.	
2011/0226919 A1	9/2011	Fryzek et al.	2015/0308662 A1	10/2015	Vice et al.	
2011/0255292 A1	10/2011	Shen	2015/0345761 A1	12/2015	Lawlor	
2011/0267828 A1	11/2011	Bazydola et al.	2015/0362159 A1	12/2015	Ludyjan	
2011/0285314 A1	11/2011	Carney et al.	2016/0084488 A1	3/2016	Wu Weiquan et al.	
2012/0020104 A1	1/2012	Biebl et al.	2016/0178181 A1	6/2016	LaDuca	
2012/0074852 A1	3/2012	Delnoij	2016/0209007 A1	7/2016	Belmonte et al.	
2012/0106176 A1	5/2012	Lopez et al.	2016/0230969 A1	8/2016	Pelletier et al.	
2012/0113642 A1	5/2012	Catalano	2016/0238225 A1	8/2016	Doust	
2012/0140442 A1	6/2012	Woo et al.	2016/0308342 A1	10/2016	Witherbee et al.	
2012/0140465 A1	6/2012	Rowlette, Jr. et al.	2016/0312987 A1	10/2016	Danesh	
2012/0162994 A1	6/2012	Wasniewski et al.	2016/0348860 A1	12/2016	Danesh	
2012/0182744 A1	7/2012	Santiago et al.	2016/0348861 A1*	12/2016	Bailey	F21V 23/002
2012/0188762 A1	7/2012	Joung et al.	2016/0366738 A1	12/2016	Boulanger et al.	
2012/0243237 A1	9/2012	Toda et al.	2017/0003007 A1	1/2017	Wronski	
2012/0250321 A1	10/2012	Blincoe et al.	2017/0005460 A1	1/2017	Lee	
2012/0266449 A1	10/2012	Krupa	2017/0045213 A1	2/2017	Williams et al.	
2012/0268688 A1	10/2012	Sato et al.	2017/0059135 A1	3/2017	Jones	
2012/0287625 A1	11/2012	Macwan et al.	2017/0138576 A1	5/2017	Peng et al.	
2012/0305868 A1	12/2012	Callahan et al.	2017/0138581 A1	5/2017	Doust	
2012/0314429 A1	12/2012	Plunk	2017/0167672 A1	6/2017	Stauner et al.	
2013/0009552 A1	1/2013	Page	2017/0167699 A1	6/2017	Schubert et al.	

(56)

References Cited

U.S. PATENT DOCUMENTS

2017/0198896 A1 7/2017 May
 2017/0284616 A1 10/2017 Coakley et al.
 2017/0307188 A1 10/2017 Oudina et al.
 2017/0307198 A1 10/2017 Shah et al.
 2018/0112857 A1 4/2018 Wronski et al.
 2018/0119907 A1 5/2018 O'Brien et al.
 2018/0142871 A1 5/2018 Morales
 2018/0156431 A1 6/2018 Zhuang et al.
 2018/0216809 A1 8/2018 Cohen
 2018/0224095 A1 8/2018 Cohen
 2018/0231197 A1 8/2018 Danesh
 2018/0283677 A1 10/2018 Cohen
 2018/0372284 A1 12/2018 Danesh et al.
 2019/0032874 A1 1/2019 Bonnetto et al.
 2019/0041050 A1 2/2019 Cairns et al.
 2019/0049080 A1* 2/2019 Danesh H02G 3/20
 2019/0063701 A1 2/2019 Lotfi et al.
 2019/0063724 A1 2/2019 Vice et al.
 2019/0093836 A1 3/2019 Danesh
 2019/0195479 A1 6/2019 Bonne
 2019/0249852 A1 8/2019 Kim
 2019/0353341 A1 11/2019 Spiro
 2020/0049326 A1 2/2020 Brown et al.
 2020/0182420 A1 6/2020 Cohen et al.
 2020/0291652 A1* 9/2020 Shen H02G 3/125
 2020/0355334 A1 11/2020 Shen et al.
 2020/0393118 A1 12/2020 Danesh et al.
 2021/0010647 A1 1/2021 Danesh et al.
 2021/0010663 A1 1/2021 Nikooyan et al.
 2021/0033268 A1 2/2021 Danesh
 2021/0071833 A1 3/2021 Hou et al.
 2021/0080081 A1 3/2021 Cohen
 2021/0080084 A1 3/2021 Danesh et al.
 2021/0222845 A1 7/2021 Kopitzke et al.
 2021/0254812 A1 8/2021 Danesh et al.
 2021/0364139 A1 11/2021 Danesh
 2022/0018522 A1 1/2022 Kopitzke et al.
 2022/0018523 A1 1/2022 Vinh et al.
 2022/0018525 A1 1/2022 Danesh
 2022/0042664 A1 2/2022 Lotfi et al.
 2022/0049841 A1 2/2022 Young et al.

FOREIGN PATENT DOCUMENTS

CA 2734369 A1 10/2013
 CA 2561459 A1 11/2013
 CA 2815067 11/2013
 CA 2848289 A1 10/2014
 CA 2998173 7/2018
 CN 2182475 Y 11/1994
 CN 201259125 Y 6/2009
 CN 101608781 A 12/2009
 CN 201636626 U 11/2010
 CN 202014067 U 10/2011
 CN 202392473 U 8/2012
 CN 202733693 U 2/2013
 CN 103307518 A 9/2013
 CN 103322476 A 9/2013
 CN 203202661 U 9/2013
 CN 203215483 U 9/2013
 CN 101498411 B 11/2013
 CN 203273663 U 11/2013
 CN 203297980 U 11/2013
 CN 203628464 U 12/2013
 CN 203641919 U 6/2014
 CN 104654142 A 5/2015
 CN 204513161 U 7/2015
 CN 204611541 U 9/2015
 CN 204829578 U 12/2015
 CN 103712135 B 4/2016
 CN 205606362 U 9/2016
 CN 206130742 U 4/2017
 CN 103154606 B 5/2017
 DE 9109828 U1 2/1992
 EP 1 672 155 A1 6/2006

EP 1688663 8/2006
 EP 2 095 938 A1 2/2008
 EP 2 306 072 A1 4/2011
 EP 2 453 169 A2 5/2012
 EP 2 193 309 B1 7/2012
 GB 2325728 12/1998
 GB 2427020 A 12/2006
 GB 2466875 7/2010
 GB 2471929 1/2014
 GB 2509772 A 7/2014
 JP 2007265961 A 10/2007
 JP 2011060450 A2 3/2011
 JP 2012064551 A2 3/2012
 JP 2015002027 A2 1/2015
 JP 2015002028 A2 1/2015
 JP 2016219335 A 12/2016
 JP 2017107699 A2 6/2017
 KR 1020110008796 A 1/2011
 KR 1020120061625 A 6/2012
 MX 2011002947 A 9/2011
 WO WO 2013/128896 A1 9/2013
 WO WO 2015/000212 A1 1/2015
 WO WO 2016152166 A2 9/2016

OTHER PUBLICATIONS

Maxim Lighting International, "Wafer LED Product Brochure", undated, 2 pages.
 Maxim Lighting International, "Convert LED Flush Mount", undated.
 Maxim Lighting International, "Views of the Wafer Flush Mount", undated.
 Maxim Lighting International, "Product/Drawing Specification Sheet", undated.
 2006 International Building Code, Section 712 Penetrations, Jan. 2006, 4 pages.
 Acrich COB Zhaga Module, Product Description, Seoul Semiconductor, Nov. 11, 2016, 39 pages.
 <<https://www.zhagastandard.org/books/book18/>>, Mar. 2017, 5 pages. Accessed on May 14, 2018.
 Bortz, J. C. et al., "Optimal design of a nonimaging TIR doublet lens for an illumination system using an LED source", Proc. SPIE 5529, Nonimaging Optics and Efficient Illumination Systems, (Sep. 29, 2004); doi: 10.1117/12.562598; <https://doi.org/10.1117/12.562598>, 10 pages.
 BXUV.GuideInfo, Fire Resistance Ratings—ANSI/UL 263, UL Online Certifications Directory, last updated Nov. 3, 2016, 27 pages.
 CEYY.GuideInfo, Outlet Boxes and Fittings Certified for Fire Resistance, UL Online Certifications Directory, last updated May 16, 2013, 2 pages.
 Canadian Office Action dated Dec. 23, 2013 from Canadian Application No. 2,778,581, 3 pages.
 Canadian Office Action dated Mar. 22, 2016 from Canadian Application No. 2,879,629, 4 pages.
 Canadian Office Action dated Dec. 6, 2016 from Canadian Application No. 2,879,629, 3 pages.
 Canadian Office Action dated Mar. 9, 2017 from Canadian Application No. 2,931,588, 5 pages.
 Canadian Office Action dated Feb. 1, 2016 from Canadian Application No. 2,879,486, 5 pages.
 Canadian Office Action dated Jun. 12, 2017 from Canadian Application No. 2,927,601, 4 pages.
 Canadian Office Action dated Aug. 11, 2017 from Canadian Application No. 2,941,051, 4 pages.
 Carlon® Zip Box® Blue™ Switch and Outlet Boxes, Product Brochure, <http://www.carlonsales.com/brochures.php>, Jun. 20, 2006, 22 pages.
 Cree LED Lamp Family Sales Sheet—Better light is beautiful light, Apr. 24, 2017, 2 pages.
 DME Series Installation Instructions, Oct. 18, 2011, 2 pages.
 DMF, Inc., "dmfLIGHTING: LED Recessed Lighting Solutions," Info sheets, Mar. 15, 2012, 4 pages.
 DMF, Inc., "dmfLIGHTING: LED Recessed Downlighting," DRD2 Product Brochure, Oct. 23, 2014, 50 pages.

(56)

References Cited

OTHER PUBLICATIONS

DMF, Inc., “dmfLIGHTING: LED Recessed Downlighting,” Product Catalog, Aug. 2012, 68 pages.

Dross, O. et al., “Review of SMS design methods and real-world applications”, Proc. SPIE 5529, Nonimaging Optics and Efficient Illumination Systems, (Sep. 29, 2004); doi: 10.1117/12.561336; <https://doi.org/10.1117/12.561336>, 14 pages.

Final Office Action dated Apr. 27, 2016 from U.S. Appl. No. 14/184,601, 19 pages.

Final Office Action dated Jul. 26, 2017 from U.S. Appl. No. 14/184,601, 18 pages.

Final Office Action dated Jan. 29, 2016 from U.S. Appl. No. 14/183,424, 21 pages.

Final Office Action dated Jun. 23, 2016 from U.S. Appl. No. 13/484,901, 18 pages.

Final Office Action dated Apr. 2, 2015 from U.S. Appl. No. 13/484,901, 13 pages.

Halo, Halo LED H4 H7 Collection, SustainabLEDesign, Cooper Lighting, (emphasis on p. 18 “H7 Collection LED Modules—Halo LED H7 Module Features,”) Mar. 28, 2012, 52 pages.

Halo, H7 LED Downlight Trims 49x Series, 6-inch LED Trims for Use with MI7x LED Modules, Cooper Lighting, ADV110422, rev. Aug. 12, 2011, 15 pages.

Halo, LED Module ML706x, Cooper Lighting, General Installation for All Modules/p. 1; Tether Installation/pp. 2-3; Installation into HALO H750x Series LED—only (Non-Screw Based), Recessed Fixture, p. 4, Oct. 20, 2009, 4 pages.

Medvedev, V. et al., “Uniform LED illuminator for miniature displays,” Proc. SPIE 3428, Illumination and Source Engineering, (Oct. 20, 1998); doi: 10.1117/12.327957; <https://doi.org/10.1117/12.327957>, 13 pages.

“Membrane Penetrations in Fire-Resistance Rated Walls,” https://www.ul.com/wp-content/uploads/2014/04/ul_MembranePenetrations.pdf, Issue 1, 2009, published Feb. 26, 2010, 2 pages.

“Metallic Outlet Boxes,” UL 514A, Underwriters Laboratories, Inc., Feb. 16, 2004 (Title Page Reprinted Aug. 10, 2007), 106 pages.

“Metallic and Non-metallic Outlet Boxes Used in Fire-rated Assembly,” <https://iaemagazine.org/magazine/2000/09/16/metallic-and-non-metallic-outlet-boxes-used-in-fire-rated-assembly/>, Sep. 16, 2000, 5 pages.

Notice of Allowance dated Mar. 26, 2018 for U.S. Appl. No. 14/184,601, 10 pages.

Non-Final Office Action dated Mar. 15, 2010 from U.S. Appl. No. 12/100,148, 8 pages.

Non-Final Office Action dated Apr. 30, 2010 from U.S. Appl. No. 12/173,232, 13 pages.

Non-Final Office Action dated Sep. 5, 2014 from U.S. Appl. No. 13/791,087, 8 pages.

Non-Final Office Action dated Jul. 20, 2015 from U.S. Appl. No. 14/184,601, 16 pages.

Non-Final Office Action dated Dec. 15, 2016 from U.S. Appl. No. 14/184,601, 18 pages.

Non-Final Office Action dated Feb. 6, 2018 from U.S. Appl. No. 15/167,682, 9 pages.

Non-Final Office Action dated Sep. 15, 2015 from U.S. Appl. No. 13/484,901, 16 pages.

Non-Final Office Action dated Oct. 16, 2014 from U.S. Appl. No. 13/484,901, 11 pages.

Non-Final Office Action dated Sep. 6, 2017 from U.S. Appl. No. 14/726,064, 8 pages.

Non-Final Office Action dated May 17, 2017 from U.S. Appl. No. 14/183,424, 20 pages.

Non-Final Office Action dated Jun. 2, 2015 from U.S. Appl. No. 14/183,424, 20 pages.

Non-Final Office Action dated Apr. 12, 2018 for U.S. Appl. No. 29/638,259, 5 pages.

Non-Final Office Action dated May 16, 2018 for U.S. Appl. No. 15/132,875, 18 pages.

Notice of Allowance dated Jan. 30, 2015 from U.S. Appl. No. 13/791,087, 9 pages.

Notice of Allowance dated Jan. 16, 2015 from U.S. Appl. No. 29/467,026, 9 pages.

Notice of Allowance dated Oct. 21, 2016 from U.S. Appl. No. 13/484,901, 7 pages.

Notice of Allowance dated Mar. 24, 2016 from U.S. Appl. No. 14/247,149, 8 pages.

Notice of Allowance dated May 22, 2018 from U.S. Appl. No. 14/183,424, 9 pages.

Notice of Allowance dated May 10, 2018 from U.S. Appl. No. 14/726,064, 7 pages.

Notice of Allowance dated Aug. 23, 2017 from Canadian Application No. 2,879,629, 1 page.

“Outlet Boxes for Use in Fire Rated Assemblies,” https://www.ul.com/wp-content/uploads/2014/04/UI_outletboxes.pdf, Apr. 2007, 2 pages.

Parkyn, W. A. et al., “New TIR lens applications for light-emitting diodes”, Proc. SPIE 3139, Nonimaging Optics: Maximum Efficiency Light Transfer IV, (Oct. 3, 1997); doi: 10.1117/12.290217, 7 pages.

Schreiber, P. et al., “Microoptics for homogeneous LED-illumination”, Proc. SPIE 6196, Photonics in Multimedia, 61960P (Apr. 21, 2006); doi: 10.1117/12.663084; <https://doi.org/10.1117/12.663084>, 11 pages.

Zhen, Y. et al., “The optimal design of TIR lens for improving LED illumination uniformity and efficiency”, Proc. SPIE 6834, Optical Design and Testing III, 68342K (Nov. 28, 2007); doi: 10.1117/12.756101, 9 pages.

Zou, H. et al., “58.1: Single-Panel LCOS Color Projector with LED Light Sources”, SID Symposium, vol. 36, Issue 1, 4 pages (May 2005).

Notice of Allowance dated Sep. 21, 2018 from U.S. Appl. No. 29/645,941, 5 pages.

“Advanced LED Solutions,” Imtra Marine Lighting. Jun. 17, 2011. 39 pages.

“Portland Bi-Color, Warm White/Red,” item:ILIM30941.Imtra Marine Products. 2012. 3 pages. Accessed at <http://www.imtra.com:80/0ade25fb-3218-4cae-a926-6abe64ffd93a/lighting-light-fixtures-downlights-3-to-4-inches-detail.htm> on Jan. 25, 2013.

“Cree LMH2 LED Modules,” Mouser Electronics. Accessed at www.mouser.com/new/cree/creelmh2 on Sep. 9, 2012. 2 pages.

“Cree LMH2 LED Module with TrueWhite Technology,” Cree Product Family Data Sheet. Dec. 21, 2011. 3 pages.

“Cree LMH2 LED Modules Design Guide,” Cree Product Design Guide. 2011. 20 pages.

“Undercabinet Pucks, Xyris Mini LED Puck Light,” ELCO Lighting. Sep. 2018. 1 page.

“LED Undercabinet Pocket Guide,” ELCO Lighting. Nov. 2, 2016. 12 pages.

“Versi LED Mini Flush,” Lithonia Lghting. Sep. 2013. 6 pages.

Notice of Allowance dated Oct. 4, 2018 from U.S. Appl. No. 15/947,065, 9 pages.

Notice of Allowance dated Sep. 19, 2018 from U.S. Appl. No. 15/167,682, 7 pages.

Non-Final Office Action dated Jun. 25, 2018 for U.S. Appl. No. 29/541,565, 10 pages.

Non-Final Office Action dated Oct. 24, 2018 for U.S. Appl. No. 15/688,266, 14 pages.

OneFrame Recessed LED Downlight. Dmflighting.com. Published Jun. 6, 2018. Retrieved at <https://www.dmflighting.com/product/oneframe> on Jun. 6, 2018. 11 pages.

International Search Report and Written Opinion in PCT/US2018/048357 dated Nov. 14, 2018, 13 pages.

Notice of Allowance dated Nov. 27, 2018 from U.S. Appl. No. 15/167,682, 11 pages.

Non-Final Office Action dated Dec. 5, 2018 from U.S. Appl. No. 14/942,937, 13 pages.

Notice of Allowance dated Jan. 2, 2019 from U.S. Appl. No. 29/541,565, 6 pages.

RACO 4 i+A882:C958n. Octagon Welded Concrete Ring, 3½ in. Deep with ½ and ¾ in. Knockouts and includes 890 cover (20-Pack). Model # 280. Accessed at <https://www.homedepot.com/p/RACO-4-in-Octagon-Welded-Concrete-Ring-3-1-2-in-Deep-with-1->

(56)

References Cited

OTHER PUBLICATIONS

2-and-3-4-in-Knockouts-and-ilcludes-890-cover-20-Pack-280/203638679 on Jan. 18, 2019. 3 pages.

RACO 4 in. Octagon Welded Concrete Ring, 6 in. Deep with 1/2 and 3/4 in. Knockouts (10-Pack). Model # 276. Accessed at <https://www.homedepot.com/p/RACO-4-in-Octagon-Welded-Concrete-Ring-6-in-Deep-with-1-2-and-3-4-in-Knockouts-10-Pack-276/203638675> on Jan. 16, 2019. 4 pages.

Notice of Allowance dated Feb. 8, 2019 from U.S. Appl. No. 29/541,565, 5 pages.

Non-Final Office Action dated Feb. 7, 2019 from U.S. Appl. No. 16/200,393, 32 pages.

Notice of Allowance dated Jan. 28, 2019 from U.S. Appl. No. 29/664,471, 8 pages.

Non-Final Office Action dated Jul. 24, 2018 from U.S. Appl. No. 29/638,259, 5 pages.

Final Office Action dated Mar. 15, 2019 from U.S. Appl. No. 15/132,875, 15 pages.

Notice of Allowance dated Apr. 1, 2019 from U.S. Appl. No. 15/167,682, 7 pages.

Notice of Allowance dated Apr. 17, 2019 from U.S. Appl. No. 29/678,478, 7 pages.

International Search Report and Written Opinion in International Patent Application No. PCT/US18/67614 dated Apr. 25, 2019, 20 pages.

CS&E PCT Collaborative Search and Examination Pilot Upload Peer Contribution in International Patent Application No. PCT/US18/67614 dated Apr. 24, 2019, 53 pages.

Specification & Features 4" Octagonal Concrete Box Covers. Orbit Industries, Inc. Accessed at <https://www.orbitelectric.com> on May 6, 2019. 1 page.

4" Octagon Concrete Boxes and Back Plates. Appleton. Accessed at www.appletonelec.com on May 6, 2019. 1 page.

RACO Commercial, Industrial and Residential Electrical Products. Hubbell. Accessed at www.Hubbell-RTB.com on May 6, 2019. 356 pages.

Imtra Marine Lighting 2008 Catalog. 40 pages.

Imtra Marine Lighting 2009 Catalog. 32 pages.

Imtra Marine Lighting Spring 2007 Catalog. 36 pages.

Final Office Action dated Jun. 6, 2019 from U.S. Appl. No. 15/688,266, 7 pages.

Non-Final Office Action dated Jun. 11, 2019 from U.S. Appl. No. 15/901,738, 6 pages.

Cooper Lighting Halo ML56 LED System Product Sheet. Mar. 2, 2015. Accessed at http://www.cooperindustries.com/content/dam/public/lighting/products/documents/halo/spec_sheets/halo-ml56600-80cri-141689-sss.pdf. 8 pages.

Kwikbrace® New Construction Braces for Lighting Fixtures or Ceiling Fans 1 1/2 in. Depth. Hubbel. Accessed at <https://hubbellcdn.com/specsheet/926.pdf> on Jun. 27, 2019. 1 page.

IC1 JB Housing 4" IC-Rated New Construction Junction Box Housing. AcuityBrands. Accessed at <https://www.acuitybrands.com/en/products/detail/845886/juno/ic1jb-housing/4-ic-rated-new-construction-junction-box-housing> on Jun. 27, 2019.

Notice of Allowance dated Jul. 31, 2019 from U.S. Appl. No. 15/167,682, 7 pages.

Supplemental Notice of Allowance dated Aug. 5, 2019 from U.S. Appl. No. 15/947,065, 2 pages.

International Search Report and Written Opinion in International Patent Application No. PCT/US19/32281 dated Aug. 2, 2019, 18 pages.

Corrected Notice of Allowance dated Sep. 27, 2019 from U.S. Appl. No. 15/167,682, 2 pages.

Final Office Action dated Sep. 27, 2019 from U.S. Appl. No. 16/200,393, 34 pages.

Notice of Allowance dated Feb. 15, 2019 from U.S. Appl. No. 15/947,065, 9 pages.

Notice of Allowance dated Oct. 1, 2019 from U.S. Appl. No. 14/942,937, 7 pages.

Delhi Rehab & Nursing Facility ELM16-70884. Vertex Innovative Solutions Feb. 25, 2016. 89 pages.

SlimSurface surface mount downlighting. Philips Lightolier 2018. 8 pages.

Be seen in the best light. Lightolier by signify. Comprehensive 2019 Lighting Catalog. 114 pages.

Cree® LMR2 LED Module. Product Family Data Sheet Cree 2011. 3 pages.

Notice of Allowance dated Oct. 16, 2019 from U.S. Appl. No. 15/132,875, 12 pages.

ML56 LED Lighting System 600 / 900 / 1200 Series Halo. Cooper Lighting Brochure 2015. Accessed at <https://images.homedepot-static.com/catalog/pdfImages/06/06d28f93-4bf6-45be-a35a-a0239606f227.pdf>. 41 pages.

Switch and Outlet Boxes and Covers Brochure. Appleton 2010. 77 pages.

Notice of Allowance dated Feb. 5, 2020 from U.S. Appl. No. 15/901,738, 8 pages.

Maxim Lighting Wafer Trifold Brochure LMXBRO1711 2017. Accessed at <https://www.maximlighting.com/Upload/download/brochure/pdf/LMXBRO1711.pdf> on Feb. 13, 2020. 2 pages.

Maxim Convert Fixture. LMXCAT1805 Maxim Main Catalog 2018 p. 639.

Maxim Wafer. LMXCAT1805 Maxim Main Catalog 2018 pp. 636-638.

Maxim Lighting Trim Trifold LMXBRO1905 2019. Accessed at <https://www.maximlighting.com/Upload/download/brochure/pdf/LMXBRO1905.pdf> on Feb. 13, 2020. 2 pages.

LED Book Price Guide 2012. DMF Light. Issued Jun. 26, 2013. 3 pages.

DLEI411 4" Recessed LED Retrofit Module. DMF Light. Issued Jun. 15, 2011. 1 page.

DLEI411 4" Recessed LED New Construction, IC. DMF Light. Issued Nov. 30, 2011. 1 page.

DLEIR411 4" Recessed LED Remodel, IC. DMF Light. Issued Jun. 15, 2011. 1 page.

3 & 4" DLE Series LED Sample Case Now Available. DMF Light. Issued Jan. 6, 2012. 1 page.

DLEI3 3" Recessed LED New Construction, IC. DMF Light. Issued Nov. 30, 2011. 2 pages.

Ridgway-Barnes, SlimSurface LED Downlight: One of the thinnest LED surface mount downlights in the market. Philips Lighting Blog. Oct. 28, 2014. Accessed at <http://applications.nam.lighting.philips.com/blog/index.php/2014/10/28/slimsurface-led-downlight-one-of-the-thinnest-led-surface-mount-downlights-in-the-market/>. 3 pages.

SlimSurface LED S5R, S7R & S10R Round 5", 7" and 10" Apertures. Lightolier by Signify. Nov. 2018. 9 pages.

Non-Final Office Action dated Apr. 2, 2020 for U.S. Appl. No. 16/522,275, 21 pages.

Notice of Allowance dated May 18, 2020 from U.S. Appl. No. 15/901,738, 7 pages.

Non-Final Office Action dated May 20, 2020 for U.S. Appl. No. 15/688,266, 6 pages.

Non-Final Office Action dated May 26, 2020 for U.S. Appl. No. 16/719,361, 10 pages.

Taiwan Office Action and translation thereof dated Jun. 12, 2020 from Taiwan Application No. 108116564, 8 pages.

Access Lighting Installation Instructions. No. 20870LEDD/20871LEDD/20872LEDD. Dec. 16, 2019. 2 pages.

Model No. 20870LEDD-WH/ACR Infinite Specification Sheet. Access Lighting. Apr. 9, 2020. 1 page.

Notice of Allowance dated Jul. 10, 2020 from U.S. Appl. No. 29/694,475, 6 pages.

Corrected Notice of Allowability dated Oct. 25, 2018 from U.S. Appl. No. 14/183,424, 3 pages.

Dmf DRD2 Recessed LED Downlight General Retrofit Junction Box Dated: Dec. 18, 2015 Downloaded Jul. 28, 2018, from <https://www.aiconlighting.com/specsheets/DMF/DRD2-Junction-Box-Retrofit-Spec-Sheet.pdf>, 6 pages.

Dmf DRD2 Recessed LED Downlight General New Construction 4", 5", 6" Aperture Dated: Aug. 31, 2016 Downloaded Jul. 28, 2018,

(56)

References Cited

OTHER PUBLICATIONS

from https://www.cansandfans.com/sites/default/files/DRD2-General-New-Construction-Spec-Sheet_7_0.pdf, 9 pages.

Mar. 5, 2016—The DMF Lighting DRD2 Recessed LED Downlight General Retrofit Junction Box—Wet Location Rated is the ideal solution for Commercial LED recessed lighting retrofit applications. web cache <https://www.alconlighting.com/dmf-drd2m.html> (downloaded Jul. 28, 2018), 6 pages.

Ex Parte Quayle Office Action dated Oct. 16, 2018 for U.S. Appl. No. 29/663,037, 7 pages.

Notice of Allowance dated Nov. 19, 2018 from U.S. Appl. No. 29/663,037, 5 pages.

Notice of Allowance dated Nov. 15, 2018 from U.S. Appl. No. 29/663,040, 5 pages.

LED modules advance in performance, standardization questions persist (Magazine). LEDs Magazine. Oct. 29, 2013. Accessed at <https://www.ledsmagazine.com/leds-ssl-design/modular-light-engines/article/16695073/led-modules-advance-in-performance-standardization-questions-persist-magazine>. 9 pages.

Octagon Concrete Box Cover with (3)½ in. & (2)¾ in. Conduit Knockouts. Garvin. Accessed at https://www.garvinindustries.com/covers-and-device-rings/concrete-slab-box-covers-adaptor-rings/flat-covers-all-styles/cbp?gclid=Cj0KCQjw9b_4BRCMARIsADMUIypJc0K80UHdDTI9C5m4BDzR3U87PRYV1NdQIBFxEWQ2I_3otTCTqEkaAi_DEALw_wcB on Jul. 20, 2020. 1 page.

Notice of Allowance dated Jul. 28, 2020 from U.S. Appl. No. 16/719,361, 8 pages.

Notice of Allowance dated Jul. 29, 2020 from U.S. Appl. No. 16/522,275, 8 pages.

Corrected Notice of Allowance dated Sep. 11, 2020 from U.S. Appl. No. 16/719,361, 2 pages.

Canadian Office Action in Application No. 2931588 dated Aug. 13, 2020, 5 pages.

Corrected Notice of Allowance dated Sep. 14, 2020 from U.S. Appl. No. 16/522,275, 2 pages.

Notice of Allowance dated Oct. 27, 2020 from U.S. Appl. No. 29/694,475, 5 pages.

Notice of Allowance dated Nov. 10, 2020 from U.S. Appl. No. 29/688,143, 6 pages.

Notice of Allowance dated Nov. 10, 2020 from U.S. Appl. No. 29/688,172, 6 pages.

Non-Final Office Action dated Nov. 30, 2020 from U.S. Appl. No. 17/000,702, 7 pages.

Notice of Allowance dated Dec. 2, 2020 from U.S. Appl. No. 29/746,262, 6 pages.

International Search Report and Written Opinion in PCT/US2020/050767 dated Dec. 9, 2020, 25 pages.

Non-Final Office Action dated Dec. 16, 2020 from U.S. Appl. No. 17/080,080, 28 pages.

Canadian Office Action in Application No. 2941051 dated Dec. 8, 2020, 5 pages.

Final Office Action dated Jan. 11, 2021 from U.S. Appl. No. 15/688,266, 7 pages.

Non-Final Office Action dated Jan. 11, 2021 from U.S. Appl. No. 16/725,606, 7 pages.

Notice of Allowance dated Jan. 15, 2021 from U.S. Appl. No. 17/000,702, 7 pages.

Notice of Allowance dated Jan. 22, 2021 from U.S. Appl. No. 17/080,080, 14 pages.

Final Office Action dated Feb. 5, 2021 from U.S. Appl. No. 16/200,393, 7 pages.

“Electrical Boxes” accessed at <http://electrical-inspector.blogspot.com/2013/06/electrical-boxes.html> Jun. 22, 2013 retrieved from Wayback Machine Archive.org on Jan. 25, 2021. 12 pages.

“Electrical Boxes Volume and Fill Calculations” accessed at <http://electrical-inspector.blogspot.com/2013/06/electrical-boxes-Volume-and-Fill-Calculations.html> Jun. 22, 2013 retrieved from Wayback Machine Archive.org on Jan. 25, 2021. 8 pages.

U.S. Appl. No. 61/881,162, filed Sep. 23, 2013. Priority application to US Publication No. 2015/0085500 to Cooper et al. 31 pages.

Non-Final Office Action dated Jan. 19, 2021 from U.S. Appl. No. 17/099,650, 15 pages.

Notice of Allowance dated Apr. 6, 2021 from U.S. Appl. No. 16/200,393, 11 pages.

Non-Final Office Action dated Apr. 12, 2021 from U.S. Appl. No. 29/694,475, 11 pages.

Notice of Allowance dated Apr. 13, 2021 from U.S. Appl. No. 16/725,606, 7 pages.

Notice of Allowance dated Apr. 26, 2021 from U.S. Appl. No. 17/080,080, 11 pages.

Corrected Notice of Allowance dated Apr. 28, 2021 from U.S. Appl. No. 16/725,606, 2 pages.

Notice of Allowance dated May 17, 2021 from U.S. Appl. No. 15/688,266, 9 pages.

Notice of Allowance dated May 24, 2021 from U.S. Appl. No. 29/688,143, 6 pages.

Notice of Allowance dated May 24, 2021 from U.S. Appl. No. 29/688,172, 6 pages.

Notice of Allowance dated May 27, 2021 from U.S. Appl. No. 16/779,865, 9 pages.

Notice of Allowance dated May 28, 2021 from U.S. Appl. No. 16/779,824, 11 pages.

Notice of Allowance dated Jun. 1, 2021 from U.S. Appl. No. 16/719,361, 7 pages.

Corrected Notice of Allowance dated Jun. 21, 2021 from U.S. Appl. No. 16/779,865, 3 pages.

Notice of Allowance dated Jul. 21, 2021 from U.S. Application Serial No. 17/318, 13 pages.

Supplemental Notice of Allowance dated Aug. 13, 2021 1 from U.S. Appl. No. 16/779,824, 3 pages.

Supplemental Notice of Allowance dated Aug. 19, 2021 1 from U.S. Appl. No. 17/318,193, 4 pages.

Notice of Allowance dated Aug. 20, 2021 1 from U.S. Appl. No. 29/764,875, 5 pages.

Notice of Allowance dated Sep. 16, 2021 from U.S. Appl. No. 16/779,865, 9 pages.

Petition for Inter Partes Review of U.S. Pat. No. 9,964,266 Pursuant to 37 C.F.R. § 42.100 et seq. *AMP Plus Inc. dbd ELCO Lighting v. DMF, Inc.*, IPR2019-01094 filed May 17, 2019. 108 pages.

IPR2019-01094 Exhibit 1001. U.S. Pat. No. 9,964,266 (“the ‘266 Patent”). 14 pages.

IPR2019-01094 Exhibit 1002. Declaration of Eric Bretschneider, Ph.D. (“Bretschneider”). 107 pages.

IPR2019-01094 Exhibit 1003. Curriculum Vitae of Dr. Bretschneider. 11 pages.

IPR2019-01094 Exhibit 1004. Excerpts from the File History of U.S. Pat. No. 9,964,266. 105 pages.

IPR2019-01094 Exhibit 1005. Imtra 2011 Marine Lighting Catalog—Advanced LED Solutions (“Imtra 2011”). 40 pages.

IPR2019-01094 Exhibit 1006. Imtra 2007 Marine Lighting Catalog (“Imtra 2007”). 36 pages.

IPR2019-01094 Exhibit 1007. U.S. Pat. No. 9,366,418 (“Gifford”). 9 pages.

IPR2019-01094 Exhibit 1008. Declaration of Colby Chevalier (“Chevalier”). 89 pages.

IPR2019-01094 Exhibit 1009. U.S. Pat. No. 7,102,172 (“Lynch”). 41 pages.

IPR2019-01094 Exhibit 1010. Illuminating Engineering Society, ANSI RP-16-10, Nomenclature and Definitions for Illuminating Engineering (approved as an American National Standard Jul. 15, 2005, approved by the IES Board of Directors Oct. 15, 2005). 4 pages.

IPR2019-01094 Exhibit 1011. Underwriters Laboratories Inc. Standard for Safety, Standard UL-8750, entitled Light Emitting Diode (LED) Equipment for Use in Lighting (1st ed. 2009). 5 pages.

IPR2019-01094 Exhibit 1012. Celanese CoolPoly® D5502 Thermally Conductive Liquid Crystalline Polymer Specification (“CoolPoly”). 1 page.

IPR2019-01094 Exhibit 1013. Illuminating Engineering Society of North America, IES Lighting Handbook (John E. Kaufman and Howard Haynes eds., Application vol. 1981) (“Lighting Handbook”). 5 pages.

(56)

References Cited

OTHER PUBLICATIONS

IPR2019-01094 Exhibit 1014. California Energy Commission, PIER Lighting Research Program: Project 2.3 Low-profile LED Luminaires Final Report (Prepared by Lighting Research Center, Jan. 2005) (“Pier LRP”). 70 pages.

IPR2019-01094 Exhibit 1015. Jim Sinopoli, Using DC Power to Save Energy and End the War on Currents, GreenBiz (Nov. 15, 2012), <https://www.greenbiz.com/news/2012/11/15/using-dc-power-save-energy-end-war-currents> (“Sinopoli”). 6 pages.

IPR2019-01094 Exhibit 1016. Robert W. Johnson, “Thought Leadership White Paper: AC Versus DC Power Distribution” (Nov. 2012) (“Johnson”). 10 pages.

IPR2019-01094 Exhibit 1017. Lumileds, LUXEON Rebel General Purpose Product Datasheet, Specification DS64 (2016) (“Luxeon Rebel”). 26 pages.

IPR2019-01094 Exhibit 1018. U.S. Pat. No. 8,454,204 (“Chang”). 11 pages.

IPR2019-01094 Exhibit 1019. U.S. Department of Energy, CALiPER Benchmark Report: Performance of Incandescent A-Type and Decorative Lamps and LED Replacements (prepared by Pacific National Laboratory, Nov. 2008) (“CALiPER 2008”). 25 pages.

IPR2019-01094 Exhibit 1020. U.S. Pat. No. 3,836,766 (“Auerbach”). 13 pages.

IPR2019-01094 Exhibit 1021. U.S. Department of Energy, CALiPER Application Summary Report 16: LED BR30 and R30 Lamps (prepared by Pacific Northwest National Laboratory, Jul. 2012) (“CALiPER 2012”). 26 pages.

IPR2019-01094 Exhibit 1022. Sandia National Laboratories, Sandia Report: “The Case for a National Research Program on Semiconductor Lighting” (Jul. 2000) (“Haitz”). 24 pages.

IPR2019-01094 Exhibit 1023. Sylvania, Post Top Street Light LED Retrofit Kit Specification, LED40POST (2009) (“Sylvania”). 4 pages.

IPR2019-01094 Exhibit 1024. Webster’s New Collegiate Dictionary (1973) (“Webster’s”). 2 pages.

IPR2019-01094 Exhibit 1025. 3M Wire Connectors and Tools Catalog 2013 (“3M Catalog”). 22 pages.

IPR2019-01094 Exhibit 1026. Wakefield Semiconductor Heat Sinks and Thermal Products 1974 Catalog (“Wakefield”). 3 pages.

IPR2019-01094 Exhibit 1027. U.S. Department of Energy, Solid-State Lighting Research and Development Portfolio: Multi-Year Program Plan FY’07-FY’12 (prepared by Navigant Consulting, Inc., Mar. 2006) (“DOE 2006”). 129 pages.

IPR2019-01094 Exhibit 1028. U.S. Department of Energy, Solid-State Lighting ResearA1023:C1043elopment: Multi-Year Program Plan (Apr. 2013) (“DOE 2013”). 89 pages.

Declaration of Colby Chevalier from Central District of California Civil Docket for Case #: 2:18-cv-07090-CAS-GJS filed Jun. 3, 2019, signed Jun. 3, 2019. 2 pages.

Docket Listing in Inter Partes Review of U.S. Pat. No. 9,964,266. *Docket Navigator AMP Plus, Inc. d/b/a Elco Lighting et al v. DMF, Inc.* PTAB-IPR2019-01094. Downloaded Mar. 25, 2020. 4 pages.

Petition for Inter Partes Review of U.S. Pat. No. 9,964,266 Pursuant to 37 C.F.R. § 42.100 et seq. *AMP Plus Inc. dbd ELCO Lighting v. DMF, Inc.* PTAB-IPR2019-01500 filed Aug. 14, 2019. 99 pages.

Docket Listing in Inter Partes Review of U.S. Pat. No. 9,964,266. *AMP Plus, Inc. d/b/a ELCO Lighting et al v. DMF, Inc.* PTAB-IPR2019-01500. Downloaded Mar. 25, 2020. 3 pages.

Civil Action No. 2:18-cv-07090. Complaint For Infringement And Unfair Competition. *DMF, Inc. v. AMP Plus, Inc. d/b/a ELCO Lighting*. 52 pages. Dated Aug. 15, 2018.

Docket Listing in Civil Action No. 2:18-cv-07090. *DMF, Inc. v. AMP Plus, Inc. d/b/a ELCO Lighting et al CDCA-2-18-cv-07090*. Downloaded on Mar. 25, 2020. 39 pages.

Civil Action No. 2:19-cv-4519. Complaint For Patent Infringement. *DMF, Inc. v. AMP Plus, Inc. d/b/a ELCO Lighting*. 52 pages dated May 22, 2019. 23 pages.

Docket Listing in Civil Action No. 2:19-cv-4519. *DMF Inc v. AMP Plus, Inc. d/b/a ELCO Lighting et al CDCA-2-19-cv-04519*. Downloaded on Mar. 25, 2020. 3 pages.

Decision Denying Institution of Inter Partes Review of U.S. Pat. No. 9,964,266 in IPR2019-01500 dated Mar. 17, 2020. 21 pages.

Defendants’ Notice of Prior Art Pursuant To 35 U.S.C. § 282 in Civil Action No. 2:18-cv-07090-CAS-GJS dated Feb. 28, 2020. 7 pages.

Defendant AMP Plus, Inc.’s Opposition to DMF’s Motion for Summary Judgement in Civil Action No. 2:18-cv-07090-CAS-GJS filed Feb. 10, 2020. 32 pages.

Declaration of Eric Bretschneider, Ph.D In Support of Amp Plus, Inc.’s Opposition to Dmf, Inc.’s Motion for Partial Summary Judgment in Civil Action No. 2:18-cv-07090-CAS-GJS filed Feb. 10, 2020. 210 pages.

Plaintiff DMF’s Reply in Support Of Motion For Partial Summary Judgment in Civil Action No. 2:18-cv-07090-CAS-GJS filed Feb. 18, 2020. 33 pages.

Declaration of James R. Benya In Support of Plaintiff DMF’s Motion for Summary Judgment in Civil Action No. 2:18-cv-07090-CAS-GJS filed Feb. 3, 2020. 193 pages.

Underwriters Laboratories Inc. Standard for Safely. UL 1598. Luminaires Jan. 11, 2020. 12 pages.

Exceptional LED Lighting Technology Product Portfolio. LightingScience 2012. 11 pages.

“Cree LMH2 LED Modules,” Mouser Electronics. Sep. 9, 2012. 4 pages.

Slim Line Disc. Eye LEDs Specification Sheet 2012. 2 pages.

HiBay LED Heat Sink. Wakefield-vette. Dec. 11, 2017. 1 pages.

Thermal Management of Cree® XLamp® LEDs. Cree Application Note. 2004. 19 pages.

Imtra Marine Lighting Fall 2007 Catalog. 32 pages.

Cree LMH2 LED Modules Product Family Data Sheet. Cree 2011-2014, 18 pages.

Cree LMH2 LED Modules Design Guide. Cree 2011-2015, 23 pages.

Brochure of Elco EL49A, EL49ICA, EL49RA modules. ELCO Lighting Nov. 25, 2009. 1 page.

Image of Elco E347/247 module identified by Elco in response to DMF’s Request for Production in Civil Action No. 2:18-cv-07090-CAS-GJS on Aug. 28, 2019. 1 page.

Screenshots from the Deposition of Brandon Cohen in Civil Action No. 2:18-cv-07090-CAS-GJS. Conducted Sep. 2, 2020. 8 pages.

Defendant AMP Plus, Inc.’s Initial Disclosure and Designation of Expert Witnesses in Civil Action No. 2:19-CV-4519-CAS. 37 pages.

Defendant AMP Plus, Inc. D/B/A Elco Lighting’s Supplemental Responses to Plaintiff DMF, Inc.’s First Set of Interrogatories (Nos. 1-16) in Civil Action No. 2:19-CV-4519-CAS, Redacted. 13 pages.

Final Written Decision in IPR2019-01094 dated Nov. 19, 2020, 58 pages.

Notice of Allowance dated Nov. 3, 2021 from U.S. Appl. No. 17/220,779, 7 pages.

Notice of Allowance dated Nov. 5, 2021 1 from U.S. Appl. No. 17/318,193, 11 pages.

Non-Final Office Action dated Nov. 5, 2021 from U.S. Appl. No. 17/379,748, 8 pages.

Notice of Allowance dated Nov. 8, 2021 1 from U.S. Appl. No. 29/764,875, 5 pages.

Non-Final Office Action dated Nov. 15, 2021 from U.S. Appl. No. 17/374,674, 7 pages.

Final Office Action dated Nov. 16, 2021 from U.S. Appl. No. 17/099,650, 14 pages.

Notice of Allowance dated Nov. 22, 2021 from U.S. Appl. No. 29/694,475, 7 pages.

Notice of Allowance dated Nov. 24, 2021 from U.S. Appl. No. 17/234,421, 9 pages.

Non-Final Office Action dated Nov. 30, 2021 from U.S. Appl. No. 17/395,522, 28 pages.

Non-Final Office Action dated Dec. 1, 2021 from U.S. Appl. No. 16/883,144, 23 pages.

Corrected Notice of Allowance dated Dec. 10, 2021 from U.S. Appl. No. 17/234,421, 2 pages.

Non-Final Office Action dated Dec. 13, 2021 from U.S. Appl. No. 29/711,198, 8 pages.

Corrected Notice of Allowance dated Jan. 11, 2022 from U.S. Appl. No. 29/694,475, 2 pages.

(56)

References Cited

OTHER PUBLICATIONS

Corrected Notice of Allowance dated Jan. 12, 2022 from U.S. Appl. No. 16/779,865, 9 pages.

Non-Final Office Action dated Jan. 21, 2022 from U.S. Appl. No. 17/229,668, 5 pages.

Notice of Allowance dated Feb. 14, 2022 from U.S. Appl. No. 17/473,934, 9 pages.

Non-Final Office Action dated Feb. 25, 2022 from U.S. Appl. No. 17/384,564 28 pages.

Notice of Allowance dated Mar. 11, 2022 from U.S. Appl. No. 17/118,742 13 pages.

U.S. Appl. No. 29/467,026, filed Sep. 13, 2013, Danesh et al.

U.S. Appl. No. 14/823,410, filed Aug. 11, 2015, Williams et al.

U.S. Appl. No. 14/791,249, filed Jul. 2, 2015, Lee.

U.S. Appl. No. 15/158,538, filed May 18, 2016, Kashani.

U.S. Appl. No. 15/897,955, filed Feb. 15, 2018, Fardadi et al.

U.S. Appl. No. 29/648,937, filed May 24, 2018, Kopitzke.

* cited by examiner

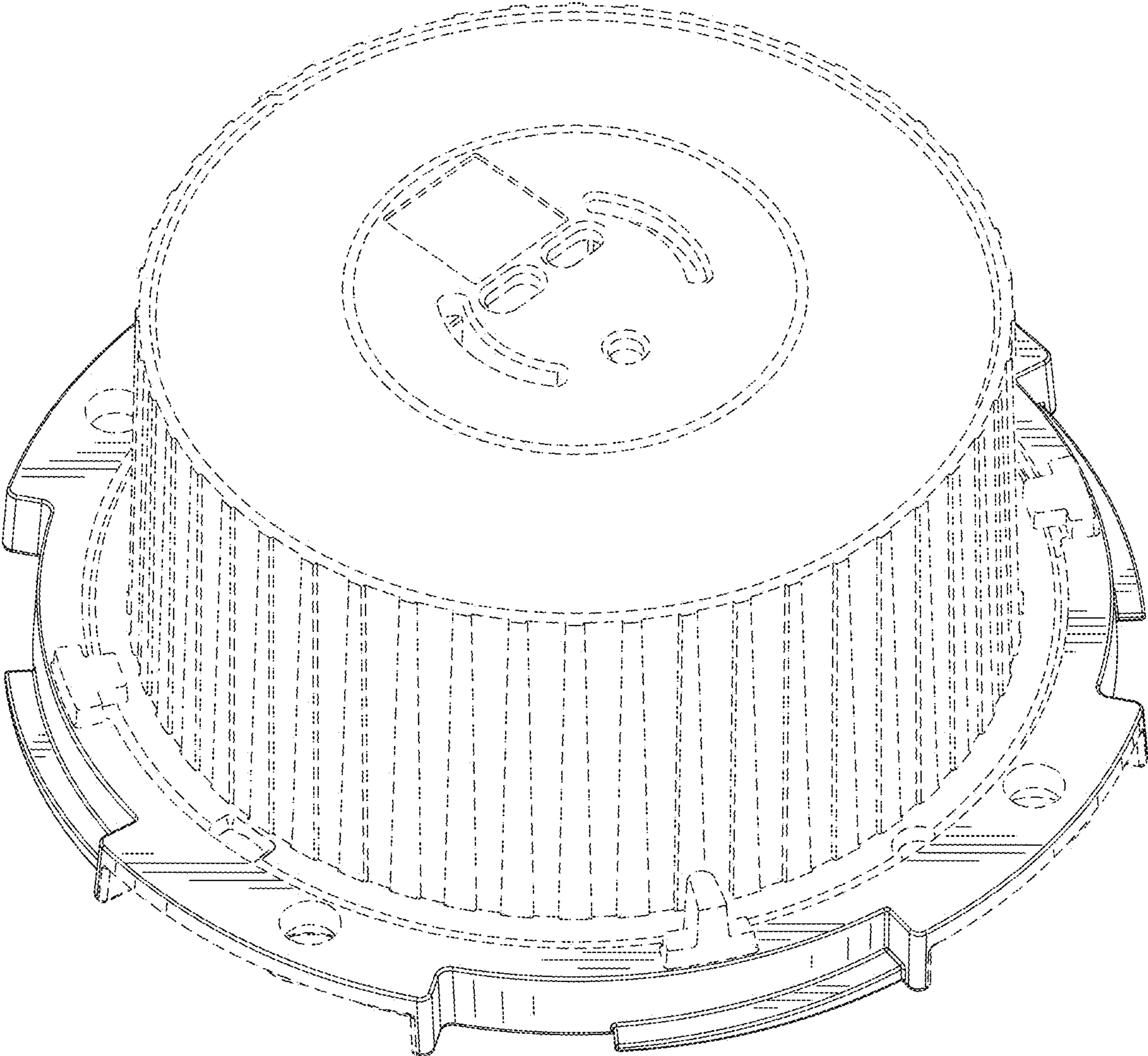

FIG. 1

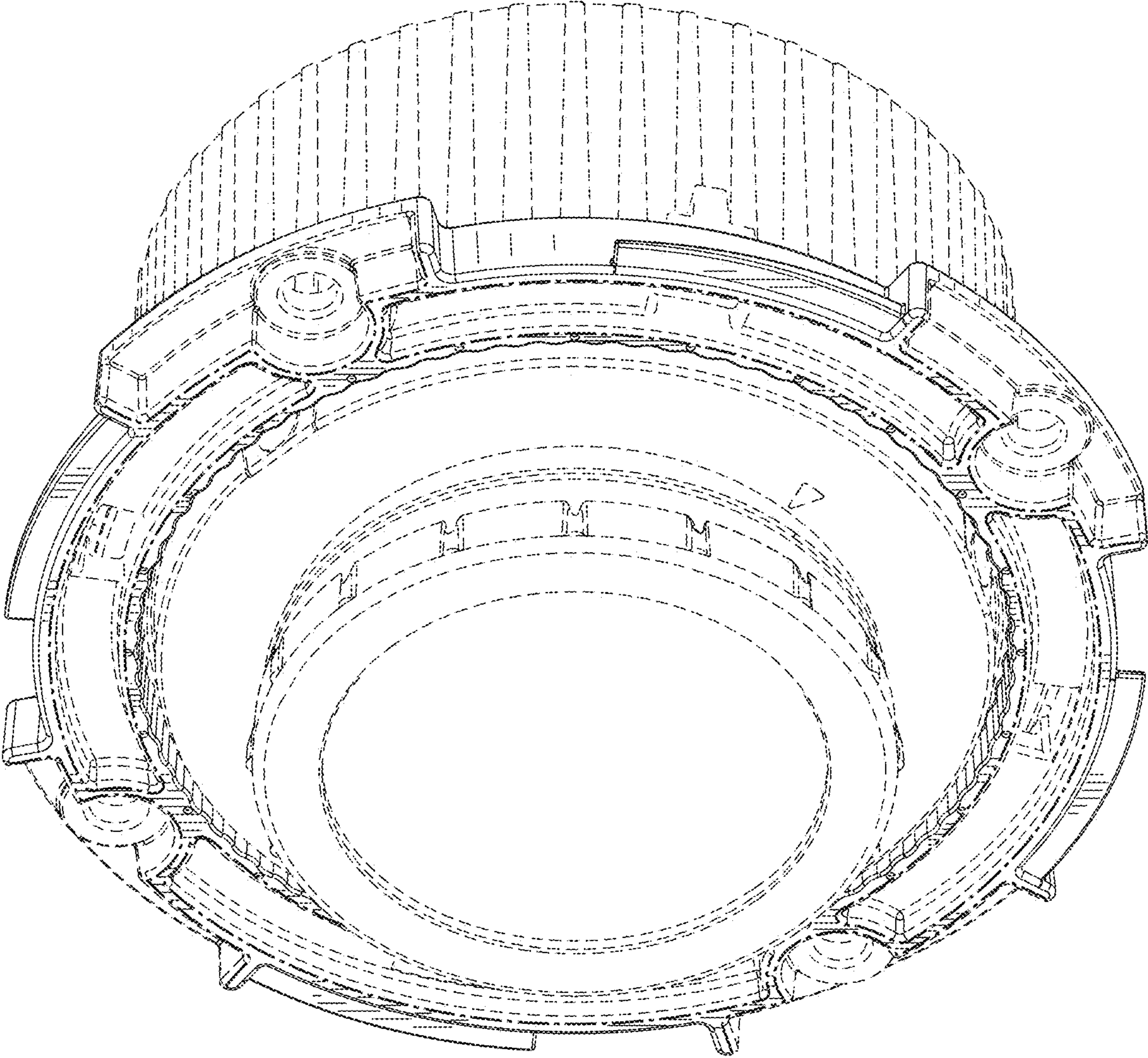

FIG. 2

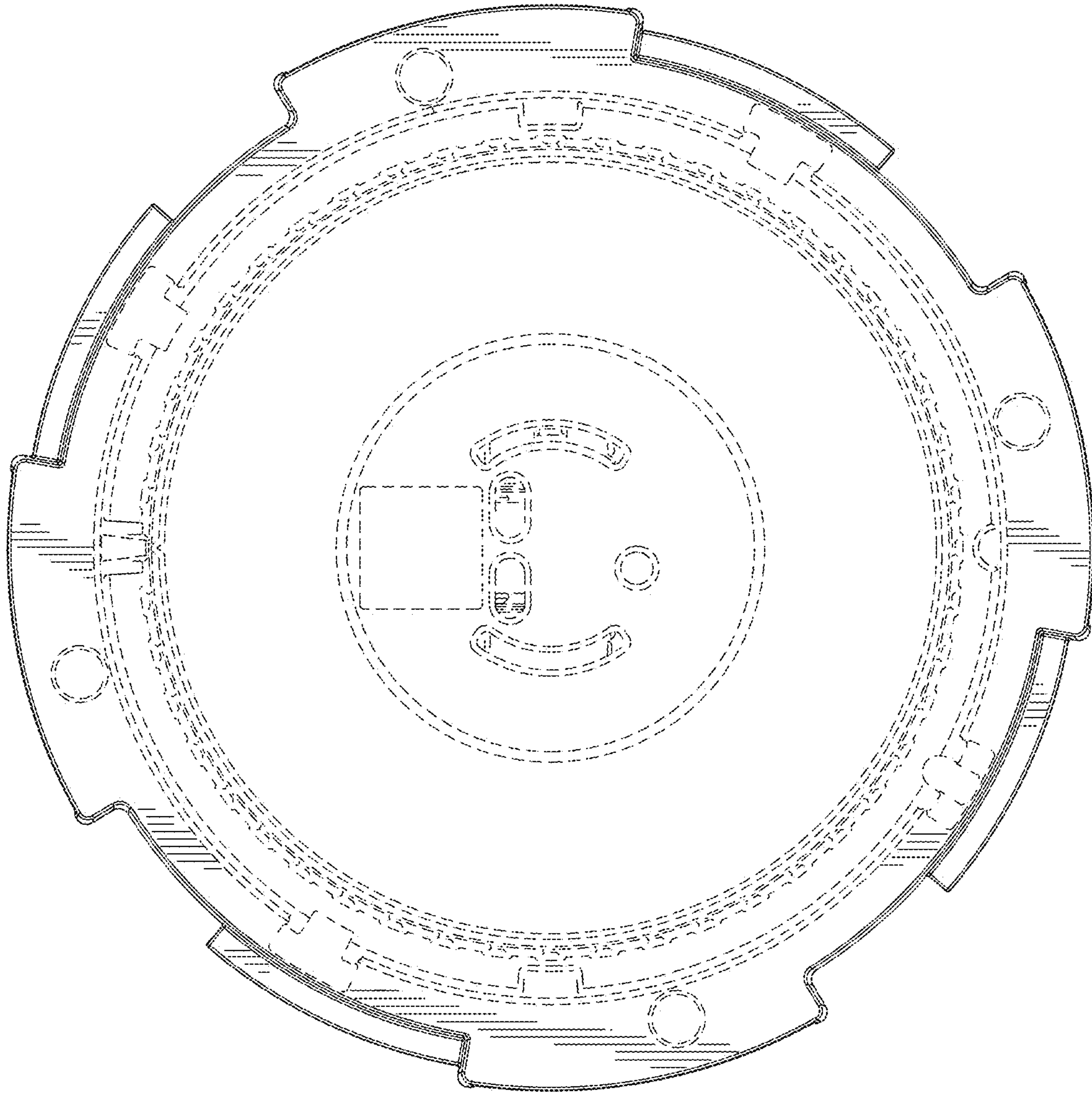

FIG. 3

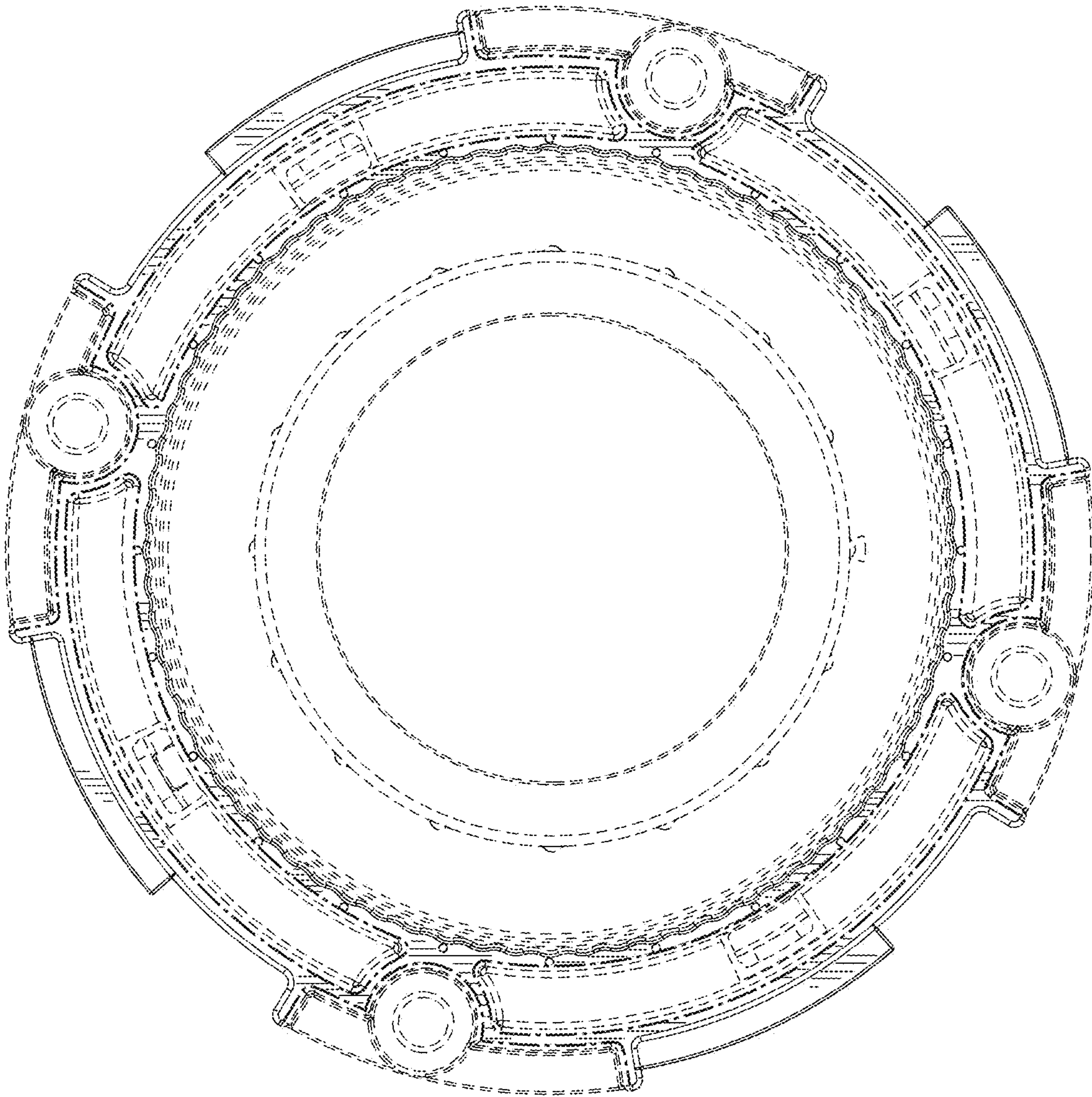

FIG. 4

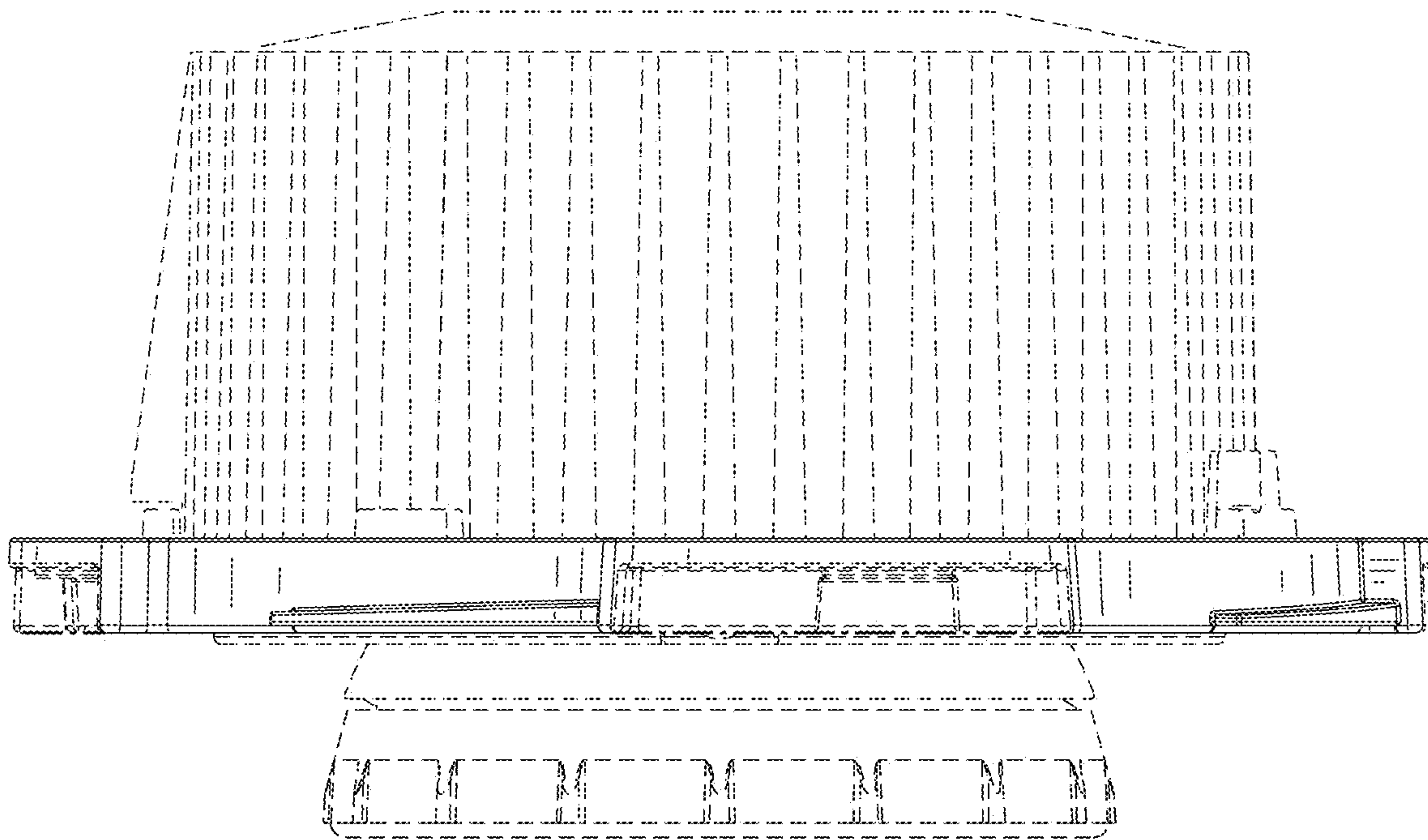

FIG. 5

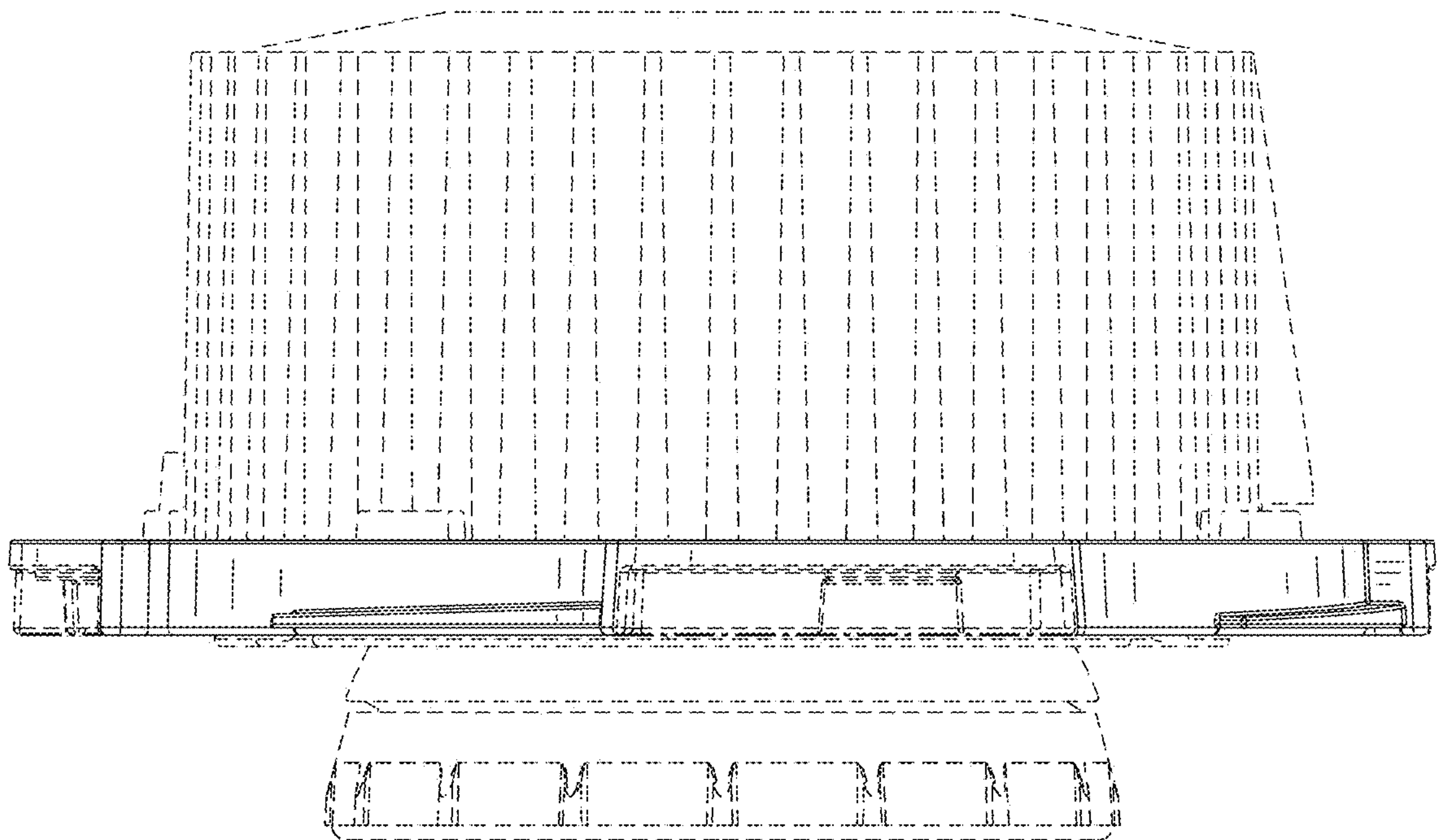

FIG. 6

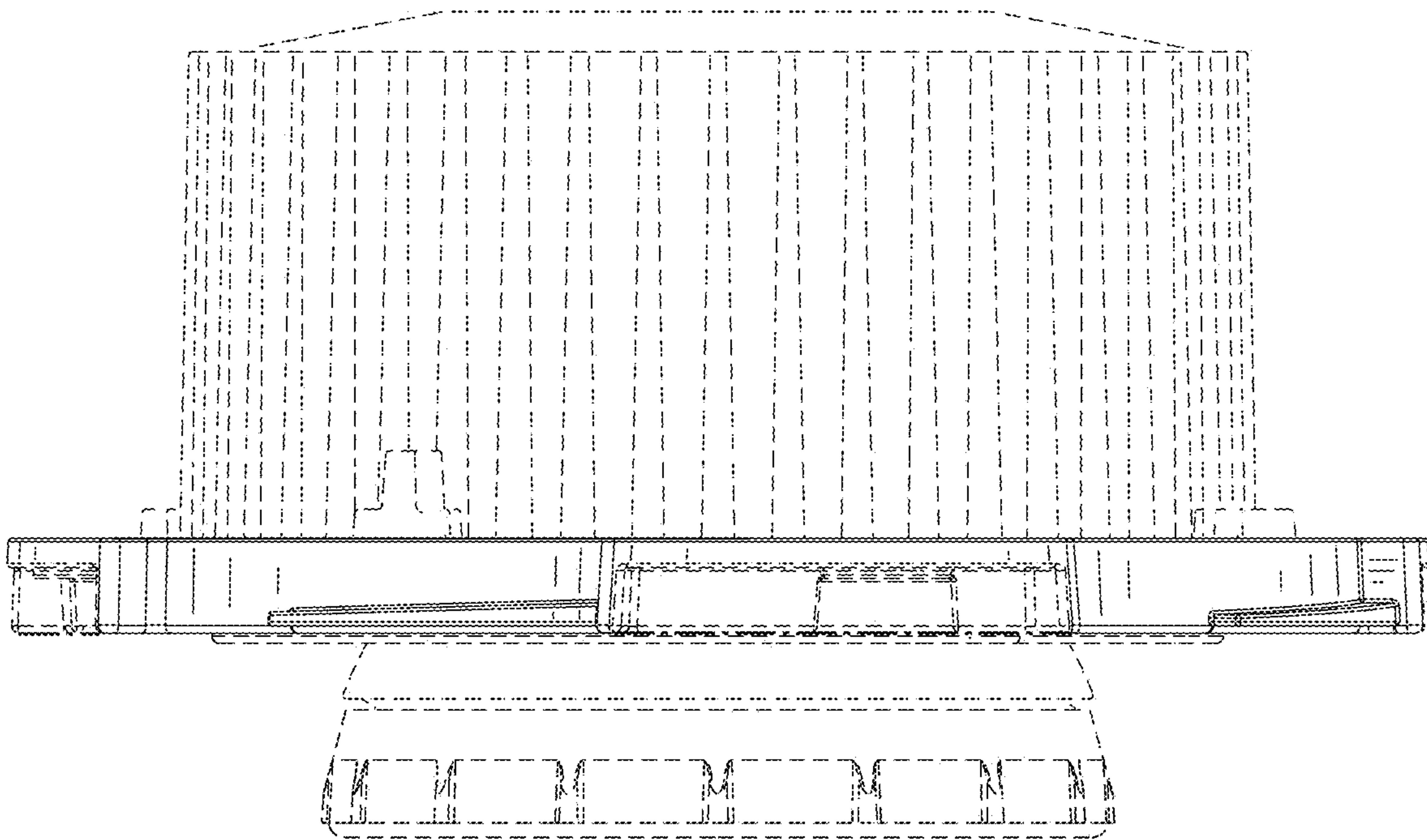

FIG. 7

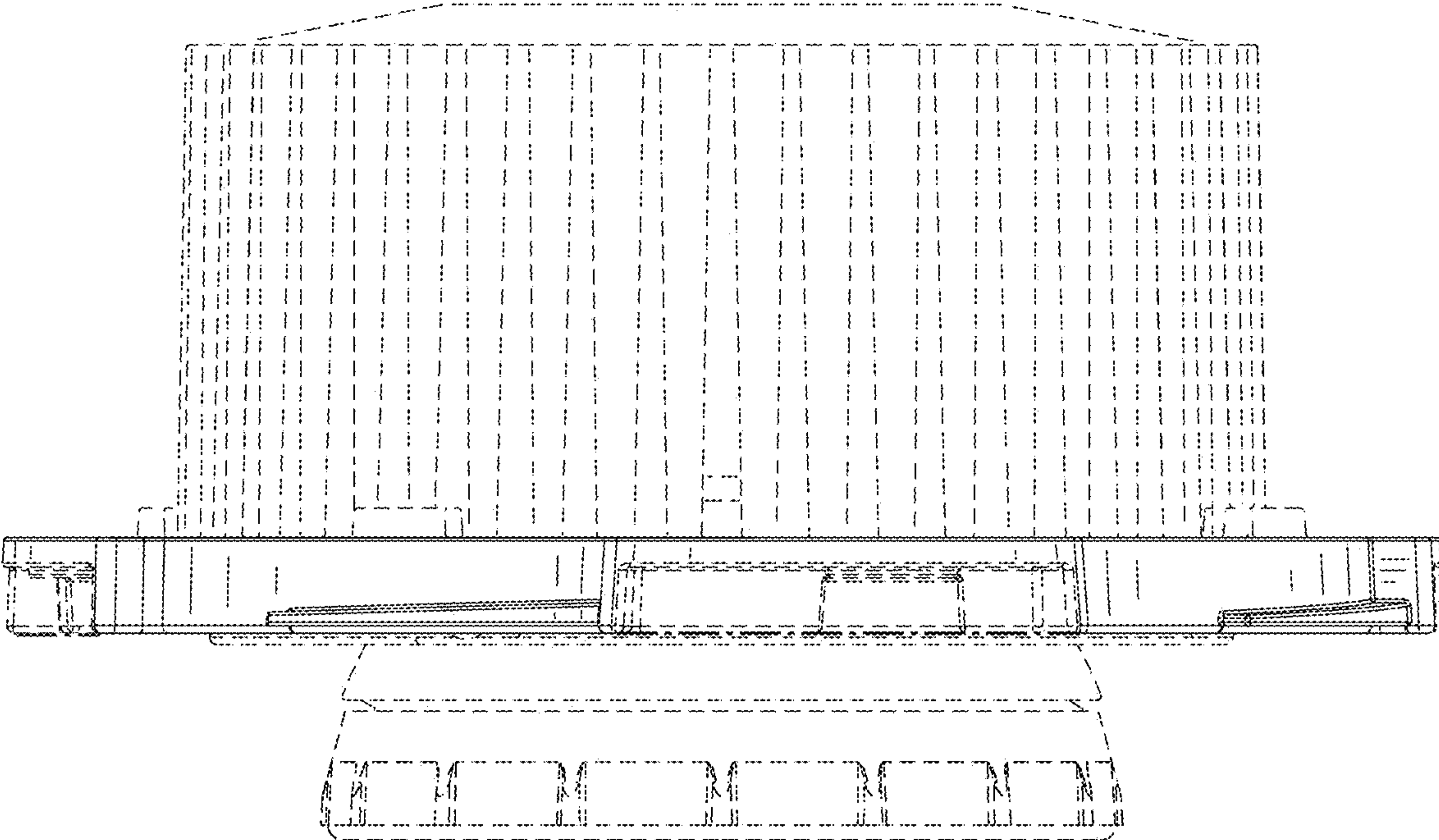

FIG. 8