

US00D969732S

(12) **United States Design Patent**
Livingston

(10) **Patent No.:** **US D969,732 S**

(45) **Date of Patent:** **** *Nov. 15, 2022**

(54) **BATTERY MODULE**

(71) Applicant: **Joule Case Inc.**, Seattle, WA (US)

(72) Inventor: **Alexander Livingston**, Seattle, WA (US)

(73) Assignee: **Joule Case Inc.**, Seattle, WA (US)

(*) Notice: This patent is subject to a terminal disclaimer.

(**) Term: **15 Years**

(21) Appl. No.: **29/711,227**

(22) Filed: **Oct. 29, 2019**

(51) **LOC (13) Cl.** **13-02**

(52) **U.S. Cl.**
USPC **D13/103**

(58) **Field of Classification Search**
USPC D13/103–106, 110, 118–119, 184, 199
CPC H01M 10/0413; H01M 10/0445; H01M 10/0436; H01M 10/05; H01M 10/052; H01M 50/10; H01M 50/103; H01M 50/20; H01M 50/204; H01M 50/209; H01M 50/258; H01M 8/24; H01M 8/2404; H01M 8/249

See application file for complete search history.

(56) **References Cited**

U.S. PATENT DOCUMENTS

D301,137 S *	5/1989	Treptow	D13/184
D311,176 S *	10/1990	Hill	D13/184
D431,810 S *	10/2000	Weng	D13/110
D455,723 S *	4/2002	Vackar	D13/184
D658,579 S *	5/2012	Miyawaki	D13/104
D684,129 S *	6/2013	Vincent	D13/184
D684,130 S *	6/2013	Vincent	D13/184

D695,681 S *	12/2013	Nam	D13/103
D860,957 S *	9/2019	Gao	D13/184
D865,693 S *	11/2019	Xiang	D13/184

* cited by examiner

Primary Examiner — Rosemary K Tarcza

(74) *Attorney, Agent, or Firm* — Volpe Koenig

(57) **CLAIM**

We claim the ornamental design for a battery module, as shown and described.

DESCRIPTION

The subject matter of this application relates generally to the subject matter disclosed by U.S. patent application Ser. No. 16/443,266, “Modular Battery Pack System With Multivoltage Bus,” filed on Jun. 17, 2019, which claims priority to U.S. Provisional application No. 62/693,230, filed on Jul. 2, 2018, “A System of Modular Power Cells, and More Particularly Stackable, Interchangeable, Reconfigurable, Independent, Portable Power and Energy Devices for the Purposes of Power Generation, Energy Capture and Storage Solutions”.

FIG. 1 is an isometric view of a battery module, showing our new design from the top, front and side.

FIG. 2 is a front side elevation view of the battery module.

FIG. 3 is a rear side elevation view of the battery module.

FIG. 4 is a side elevational view of the battery module.

FIG. 5 is a side elevational view of the battery module, shown from the side opposite the side shown in FIG. 4.

FIG. 6 is a top side view of the battery module.

FIG. 7 is a bottom side view of the battery module; and,

FIG. 8 is an environmental isometric view of the battery module, shown with a control module stacked on top and a second battery module stacked in the middle.

The broken lines in the drawings are for the purpose of illustrating environmental structure and portions of the battery module that form no part of the claimed design.

1 Claim, 6 Drawing Sheets

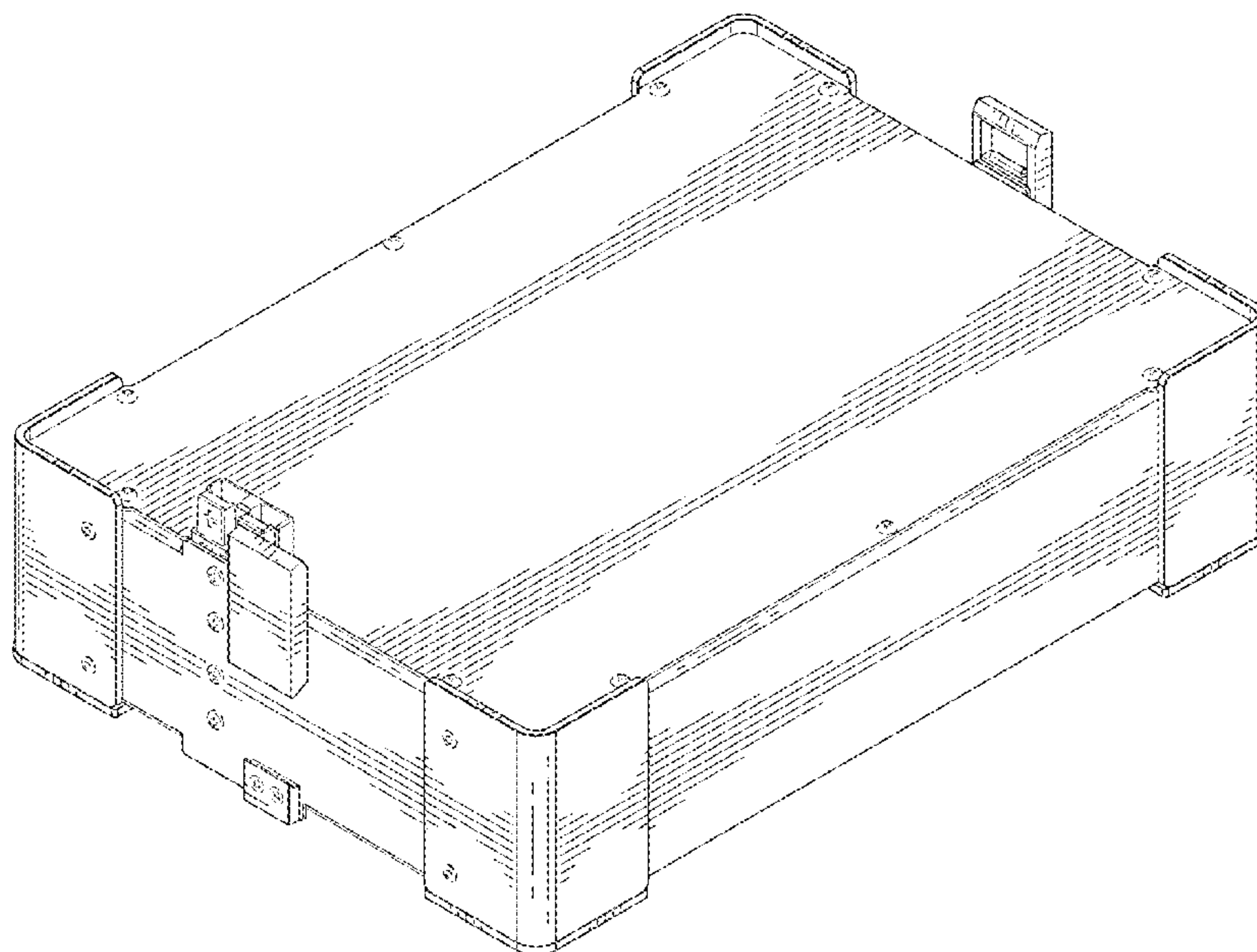

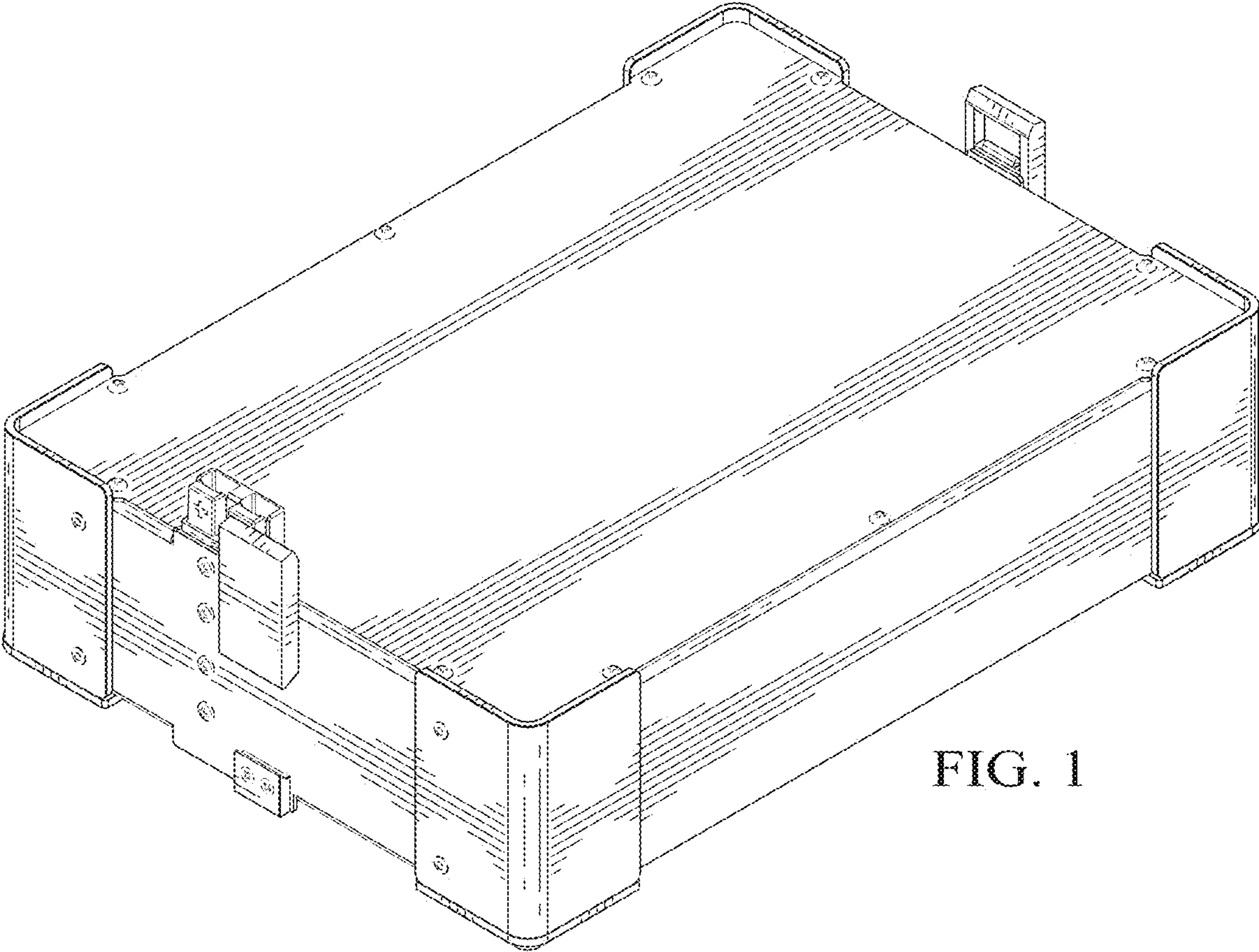

FIG. 1

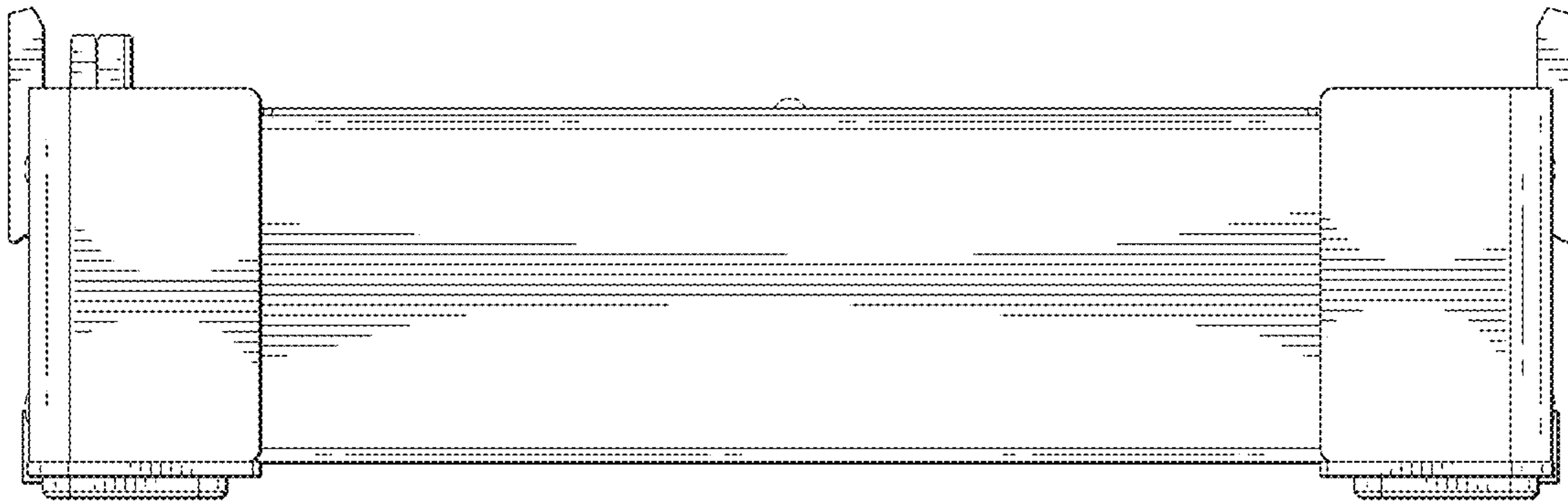

FIG. 2

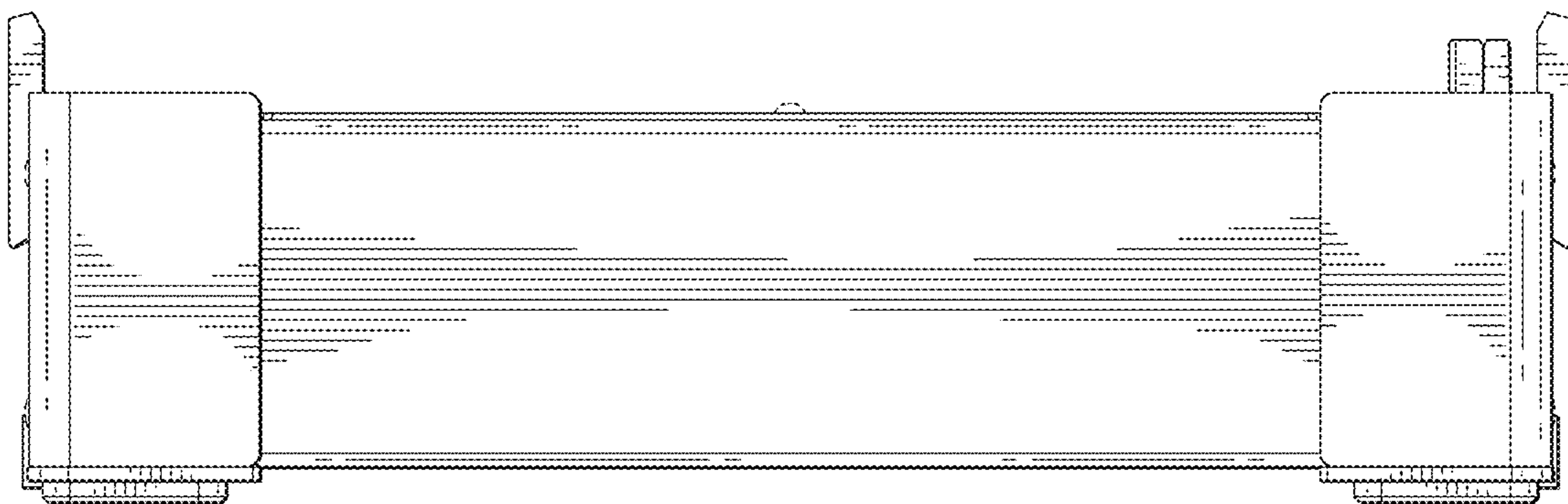

FIG. 3

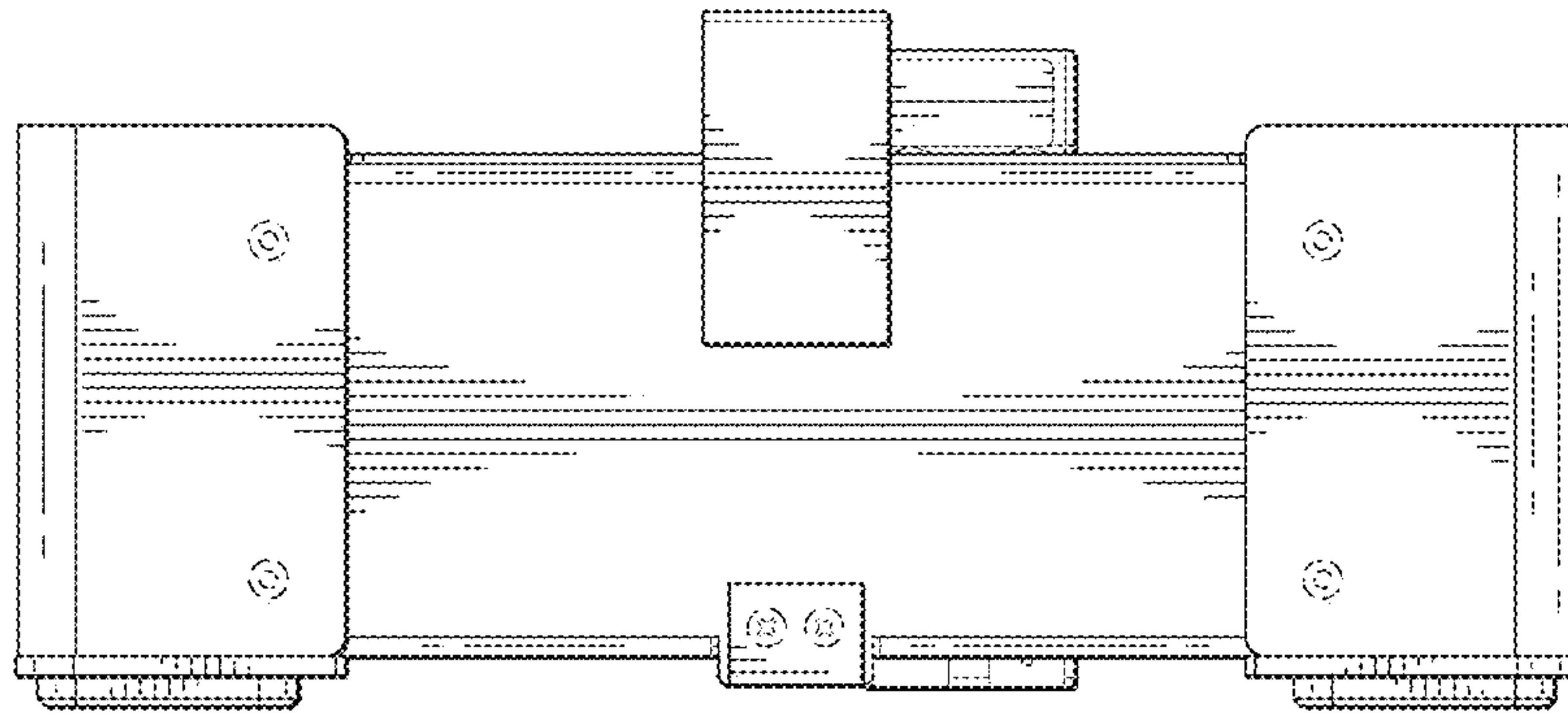

FIG. 4

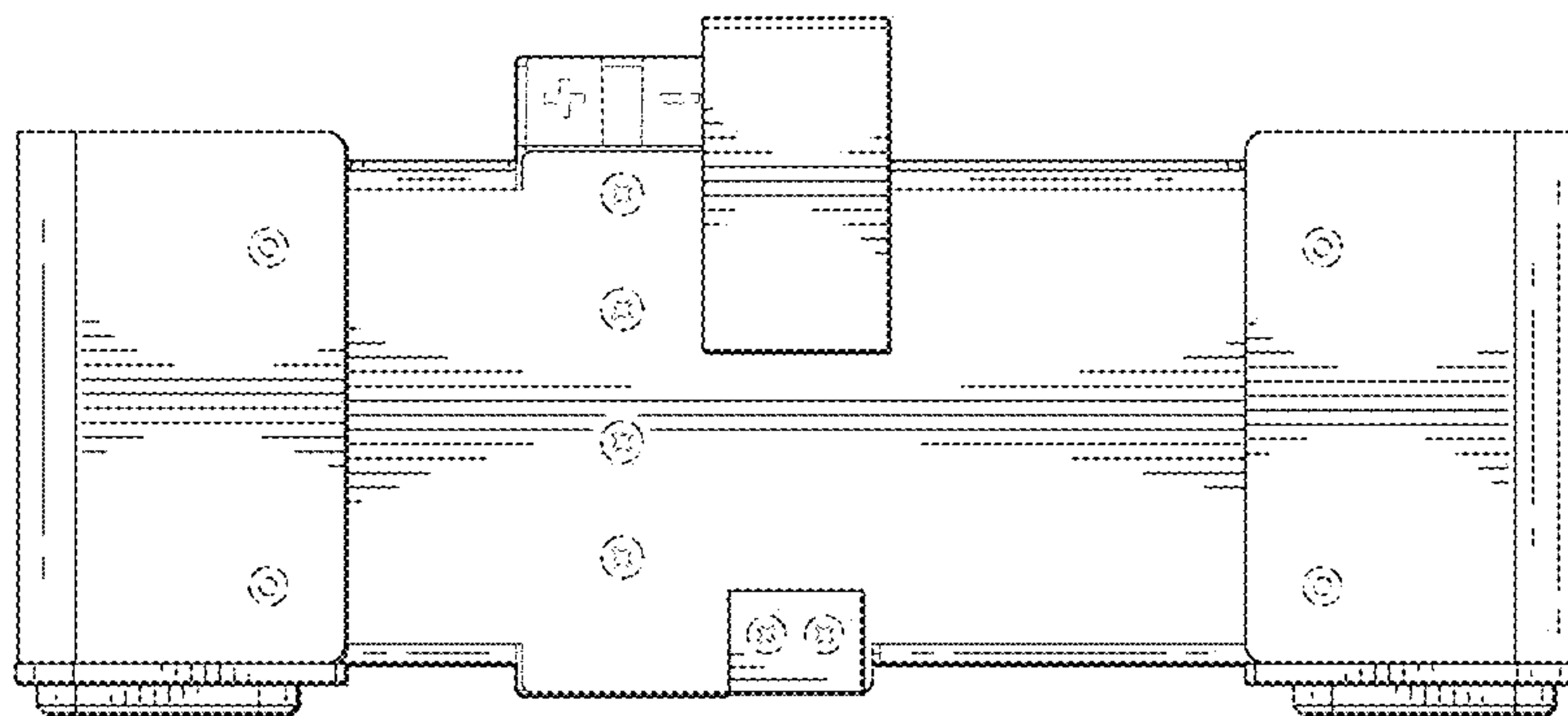

FIG. 5

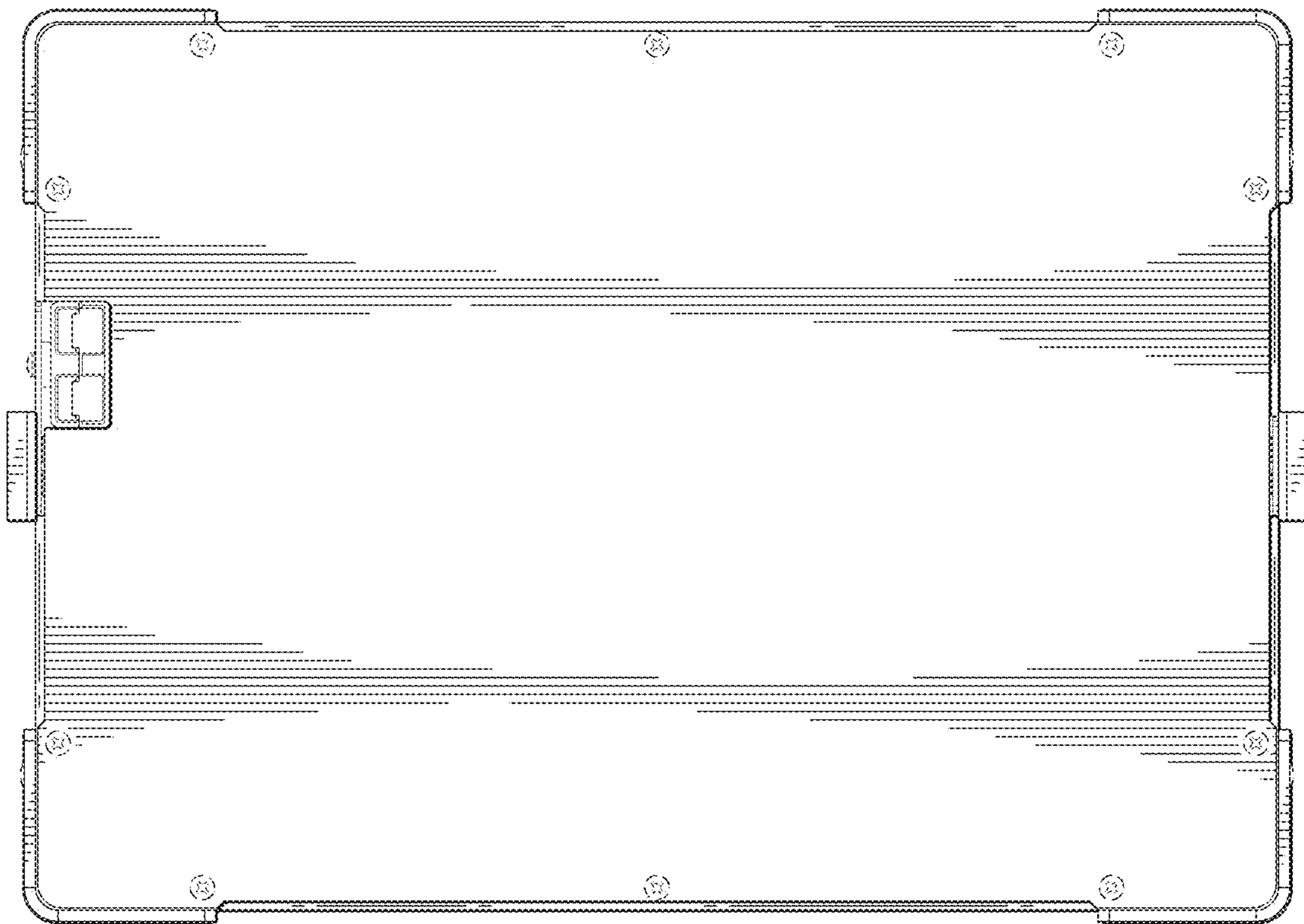

FIG. 6

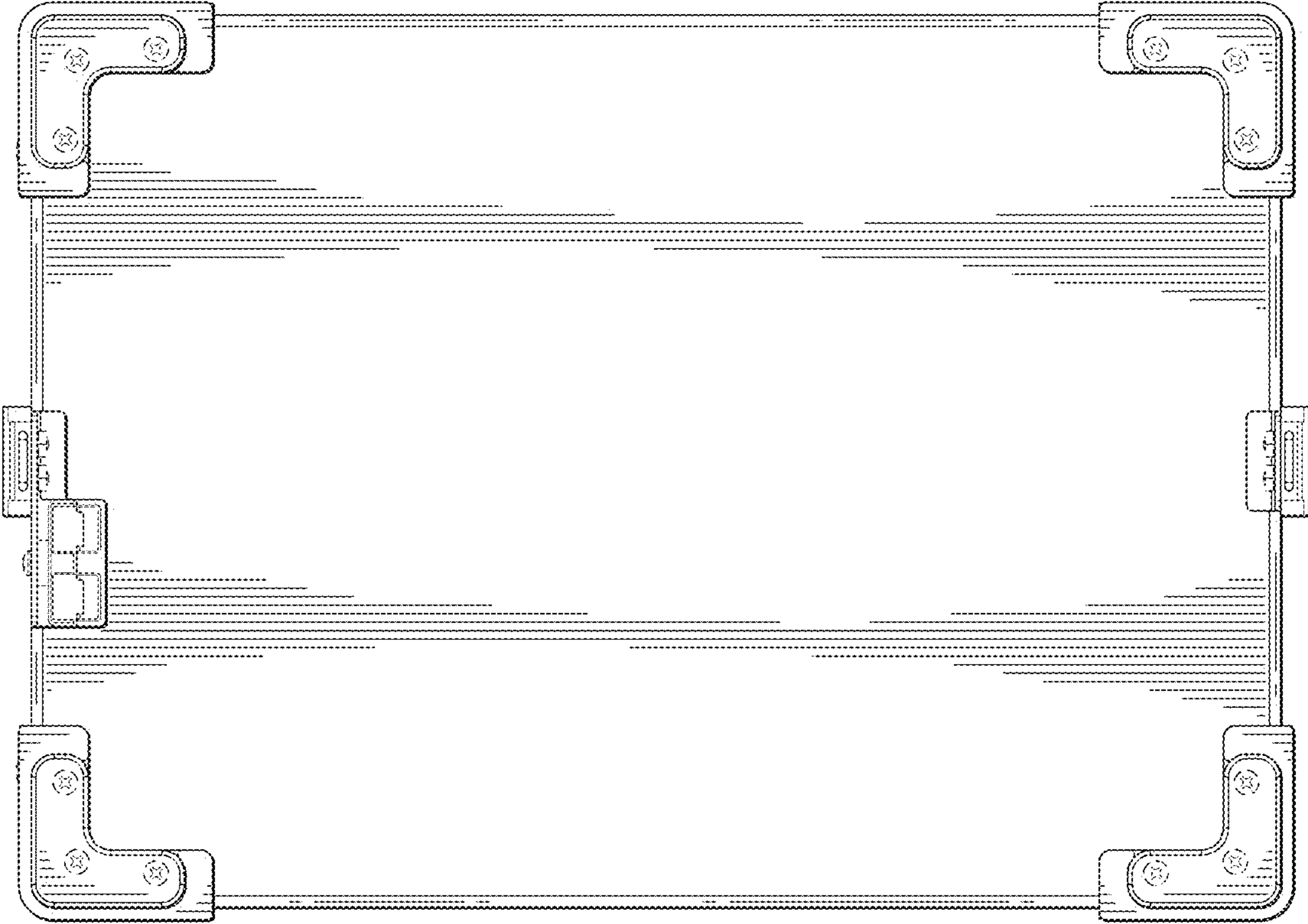

FIG. 7

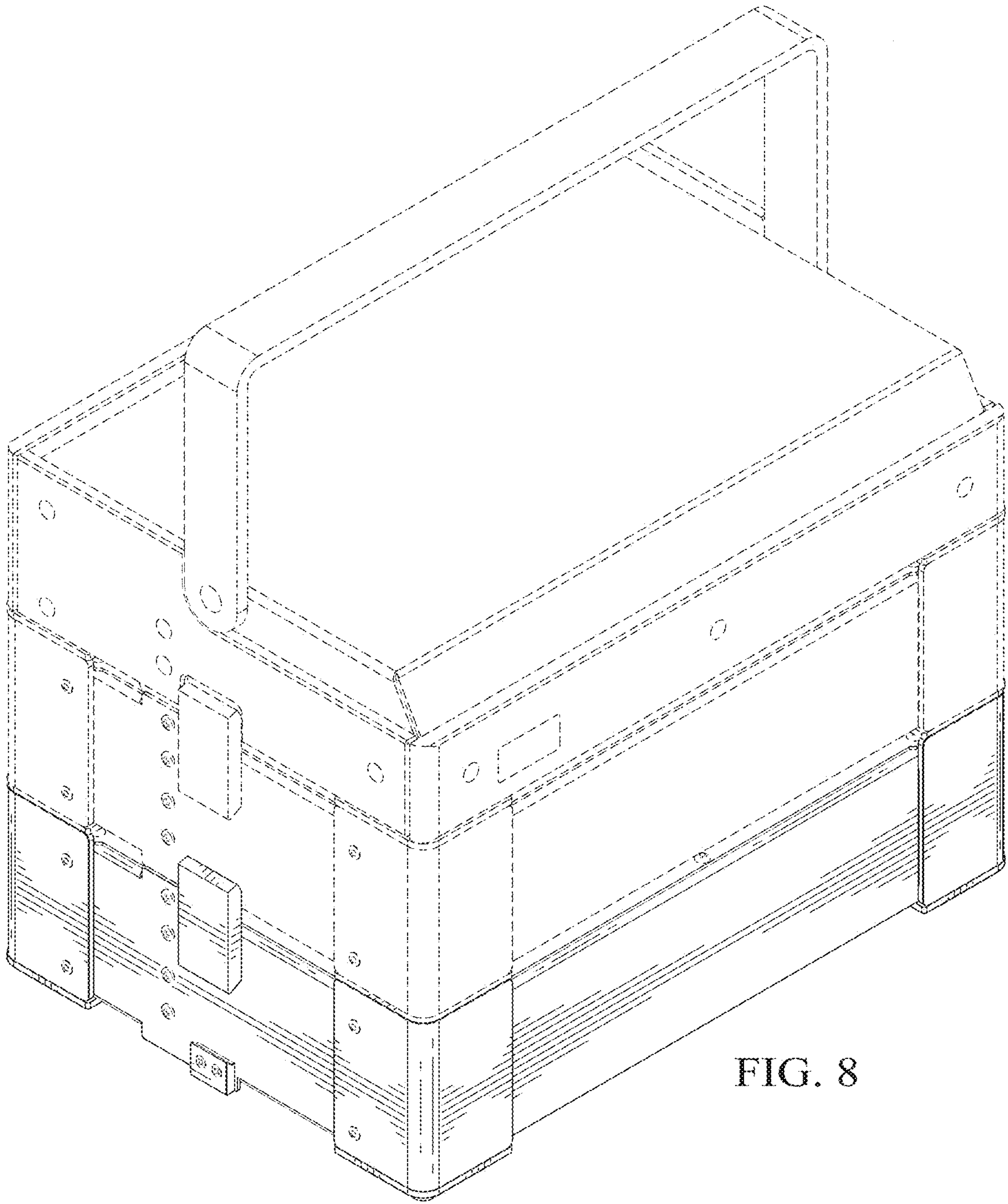

FIG. 8