



US00D969368S

(12) **United States Design Patent** (10) **Patent No.:** **US D969,368 S**
Leang et al. (45) **Date of Patent:** **** Nov. 8, 2022**

(54) **VEHICLE AUXILIARY LIGHT**
(71) Applicant: **KC IP HOLDINGS, LLC**, Gardena, CA (US)
(72) Inventors: **Bobby Leang**, Los Angeles, CA (US); **Zeke Kayne Patterson**, Valley Village, CA (US)
(73) Assignee: **KC IP HOLDINGS, LLC**, Gardena, CA (US)
(**) Term: **15 Years**
(21) Appl. No.: **29/768,275**
(22) Filed: **Jan. 28, 2021**
(51) **LOC (13) Cl.** **26-06**
(52) **U.S. Cl.**
USPC **D26/28**
(58) **Field of Classification Search**
USPC D26/28-36, 139
CPC F21S 48/00; F21S 48/10; F21S 48/115; F21S 48/225; F21S 48/1233; F21S 48/1266; F21S 48/1388; F21S 48/2268; F21V 5/00; F21V 21/04; F21V 29/004; B60Q 9/13; B60Q 9/135; B60Q 9/1375; F21W 2102/17; F21W 2103/00; F21W 2103/35; F21W 2103/55; F21W 2107/13; F21W 2107/17
See application file for complete search history.

D878,642 S * 3/2020 Ren D26/28
D884,226 S * 5/2020 Yang D26/28
D884,936 S * 5/2020 Chen D26/28
2008/0084705 A1 4/2008 Helwig et al.
2008/0089060 A1 4/2008 Kondo et al.
2019/0376661 A1 12/2019 Knettle et al.

FOREIGN PATENT DOCUMENTS

CN 202806616 U 3/2013
CN 203186200 U 9/2013
CN 105522953 A 4/2016
EP 1693249 A2 8/2006
KR 20020076942 A 10/2002

* cited by examiner

Primary Examiner — Marcus A Jackson

(74) *Attorney, Agent, or Firm* — Stetina Brunda Garred & Brucker

(57) **CLAIM**

The ornamental design for a vehicle auxiliary light, as shown and described.

DESCRIPTION

FIG. 1 is a front perspective view showing a vehicle auxiliary light of the present invention; FIG. 2 is a rear perspective view thereof; FIG. 3 is a front view thereof; FIG. 4 is a rear view thereof; FIG. 5 is a top view thereof; FIG. 6 is a left side view thereof; FIG. 7 is a right view thereof; and, FIG. 8 is a bottom view thereof. In the drawings, the broken line showings are for the purpose of illustrating portions of the vehicle auxiliary light or environmental structure that form no part of the claimed design.

1 Claim, 4 Drawing Sheets

(56) **References Cited**
U.S. PATENT DOCUMENTS
6,893,147 B2 5/2005 Schottland et al.
9,625,127 B2 4/2017 Thomsen et al.
D792,991 S * 7/2017 Wu D26/28

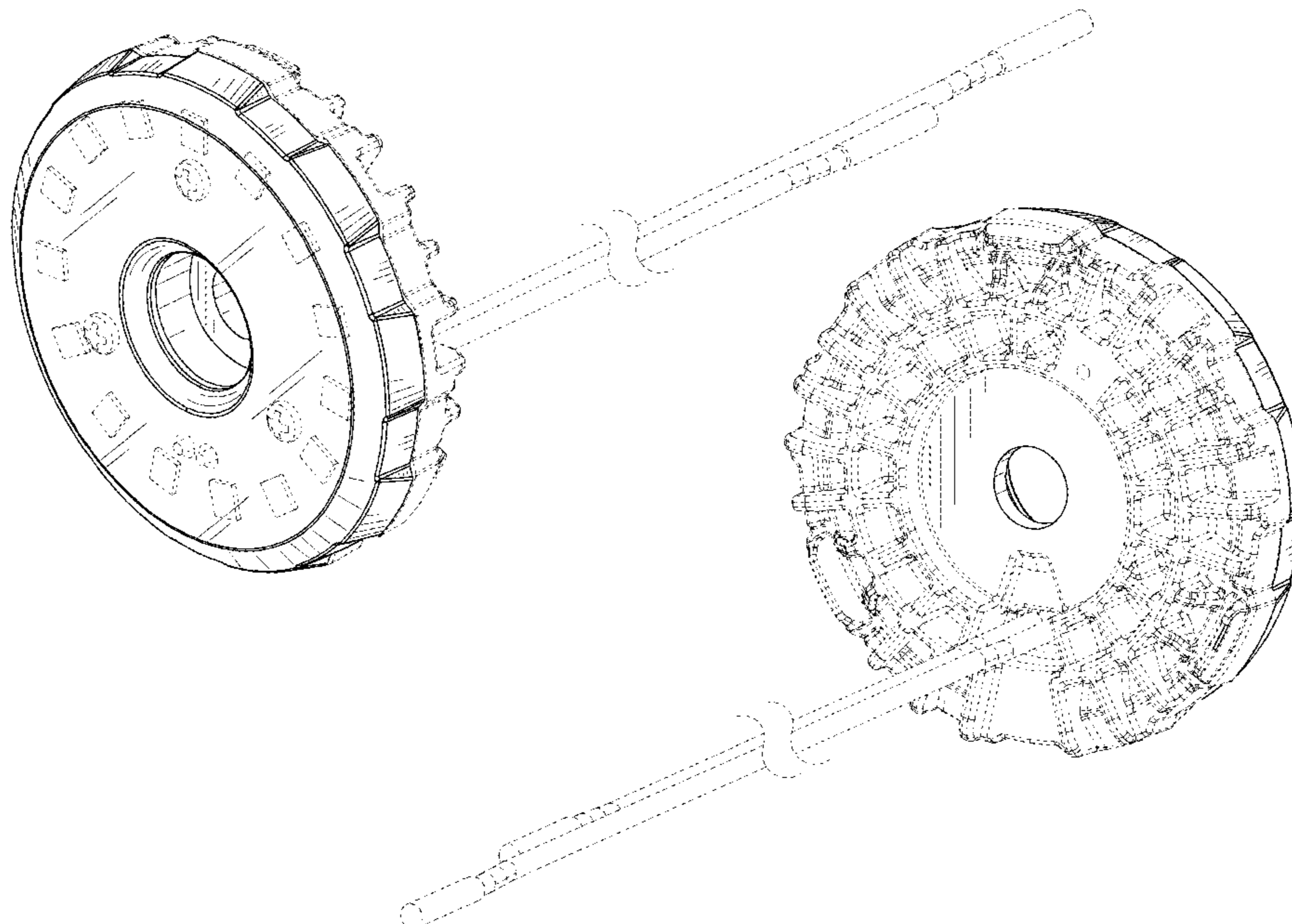

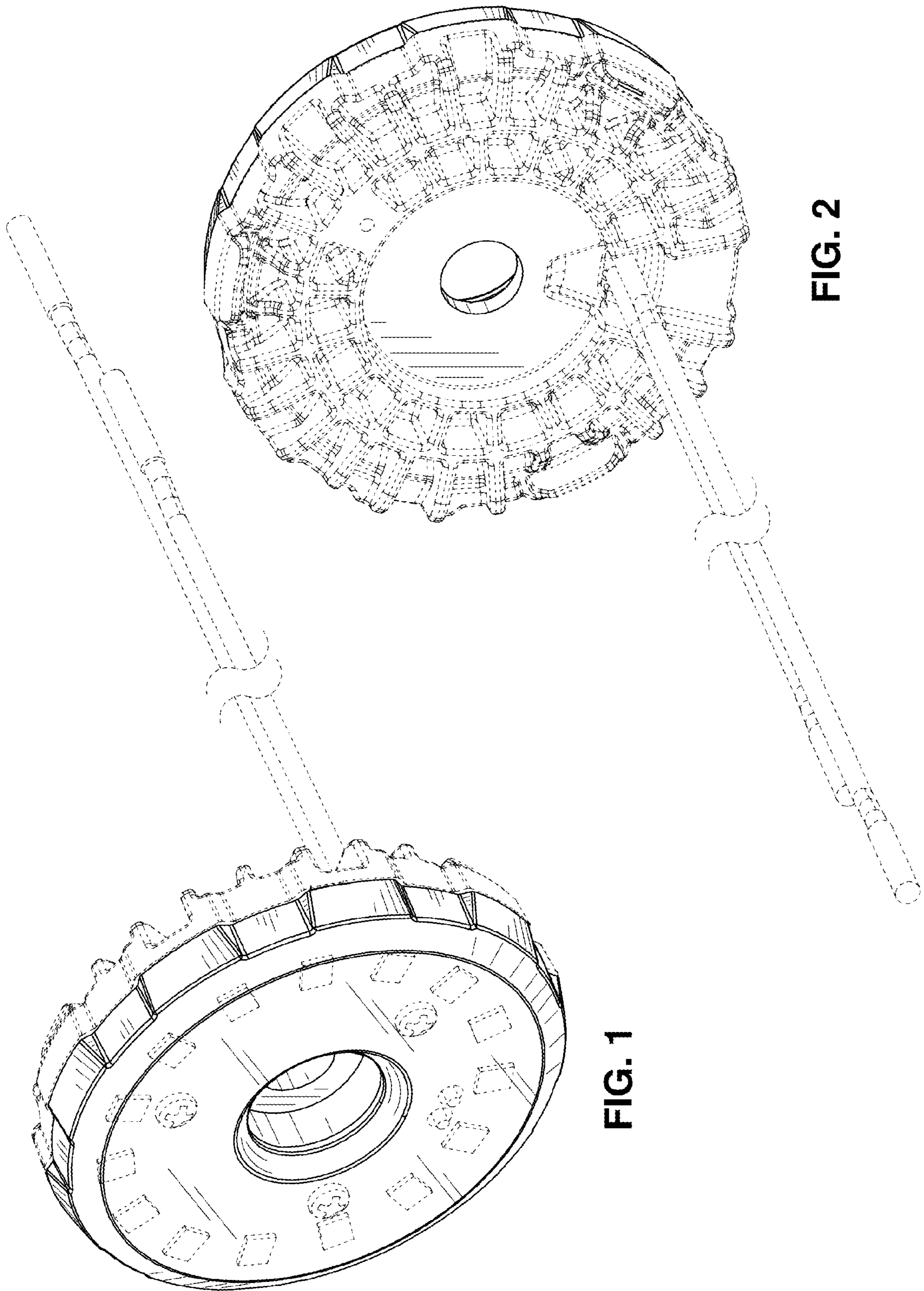

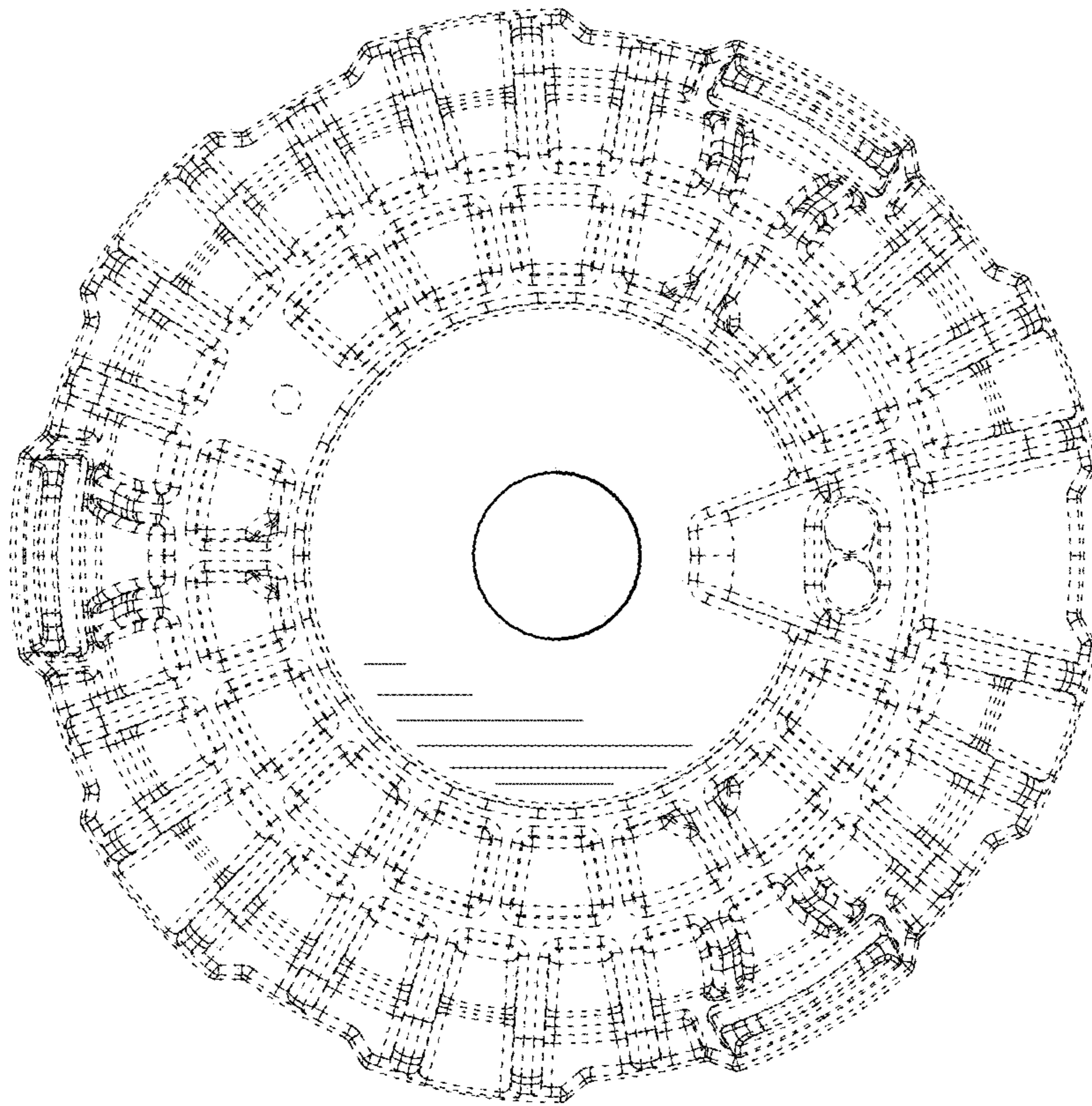

FIG. 4

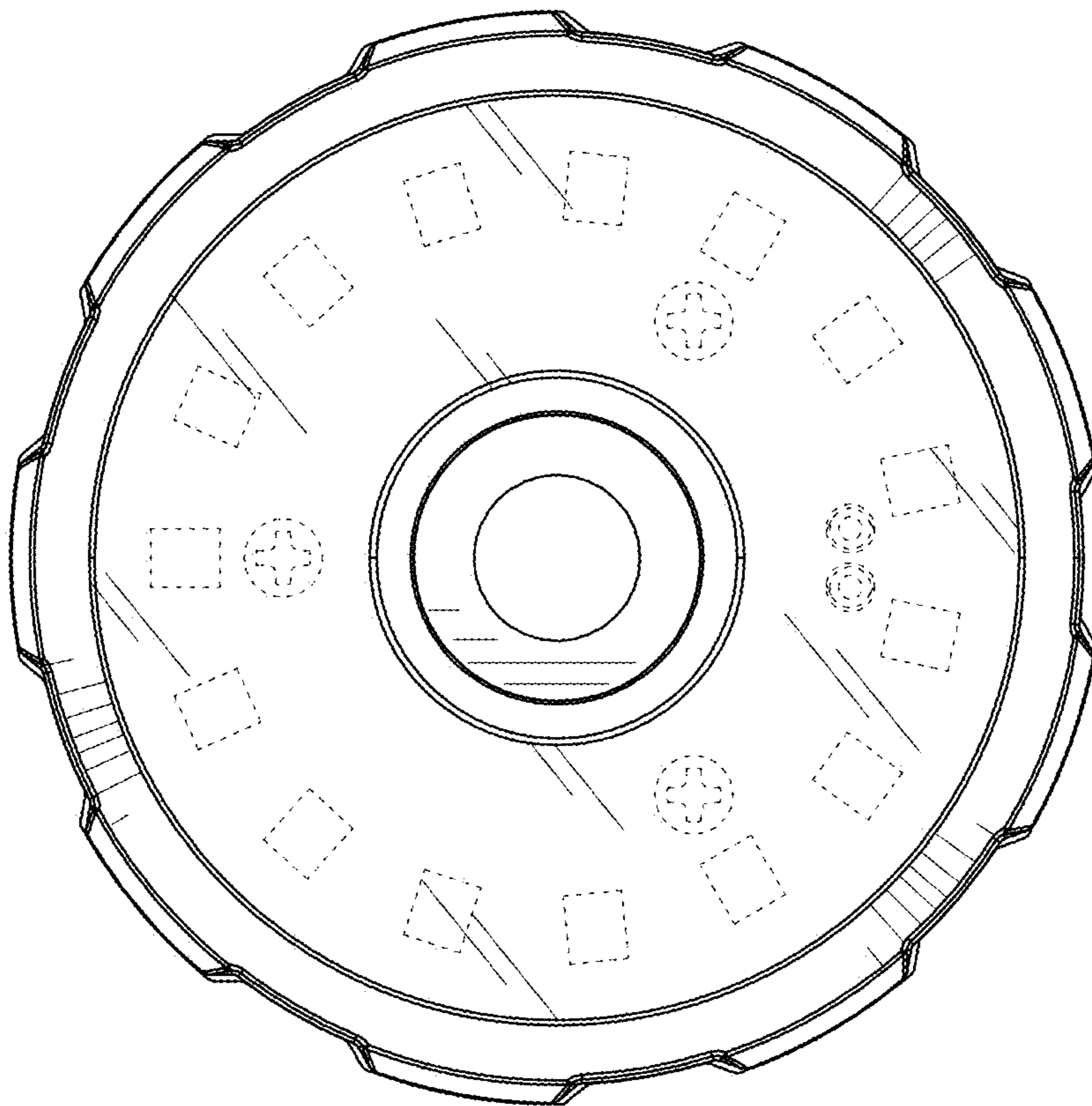

FIG. 3

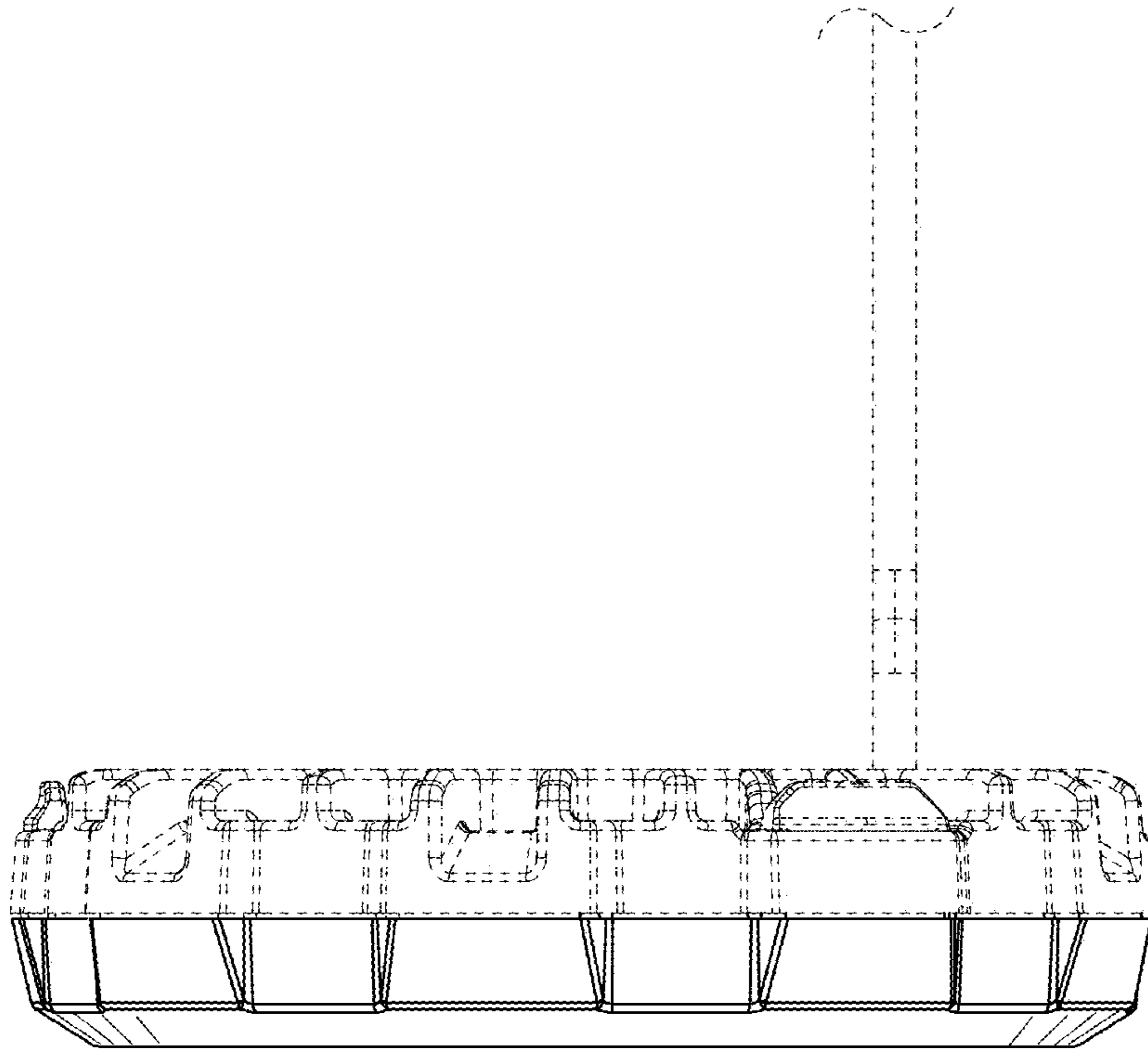

FIG. 6

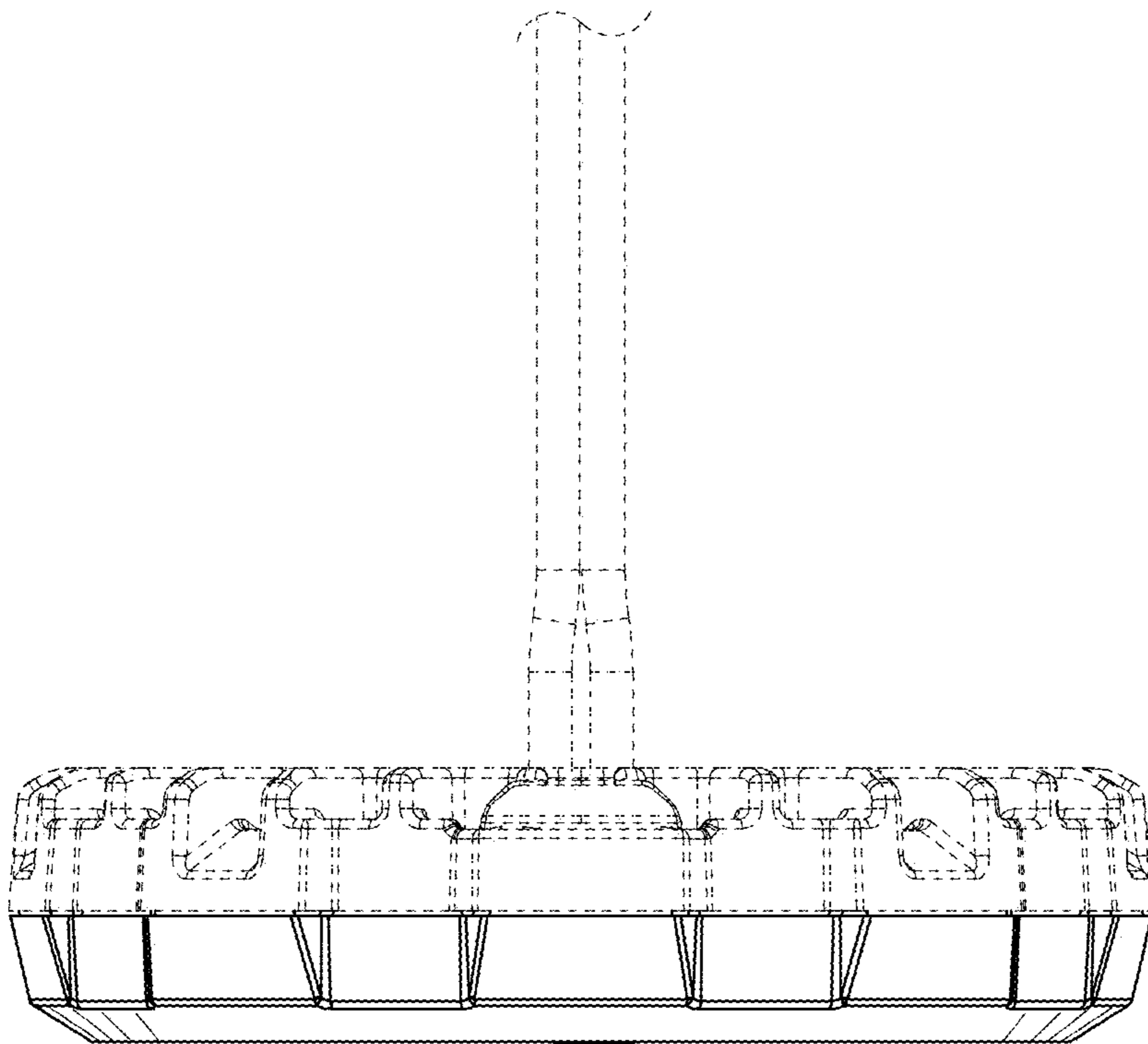

FIG. 5

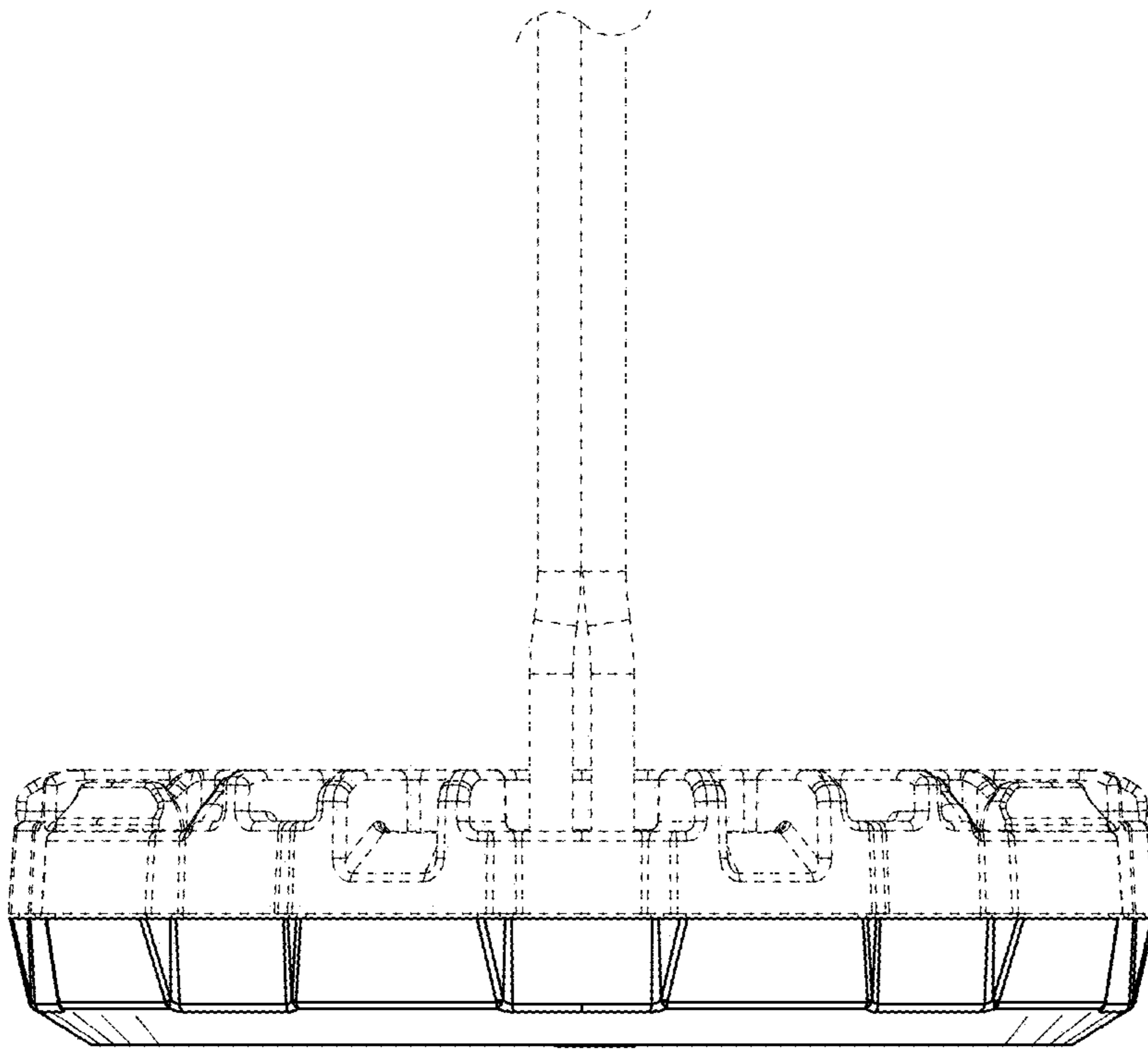

FIG. 8

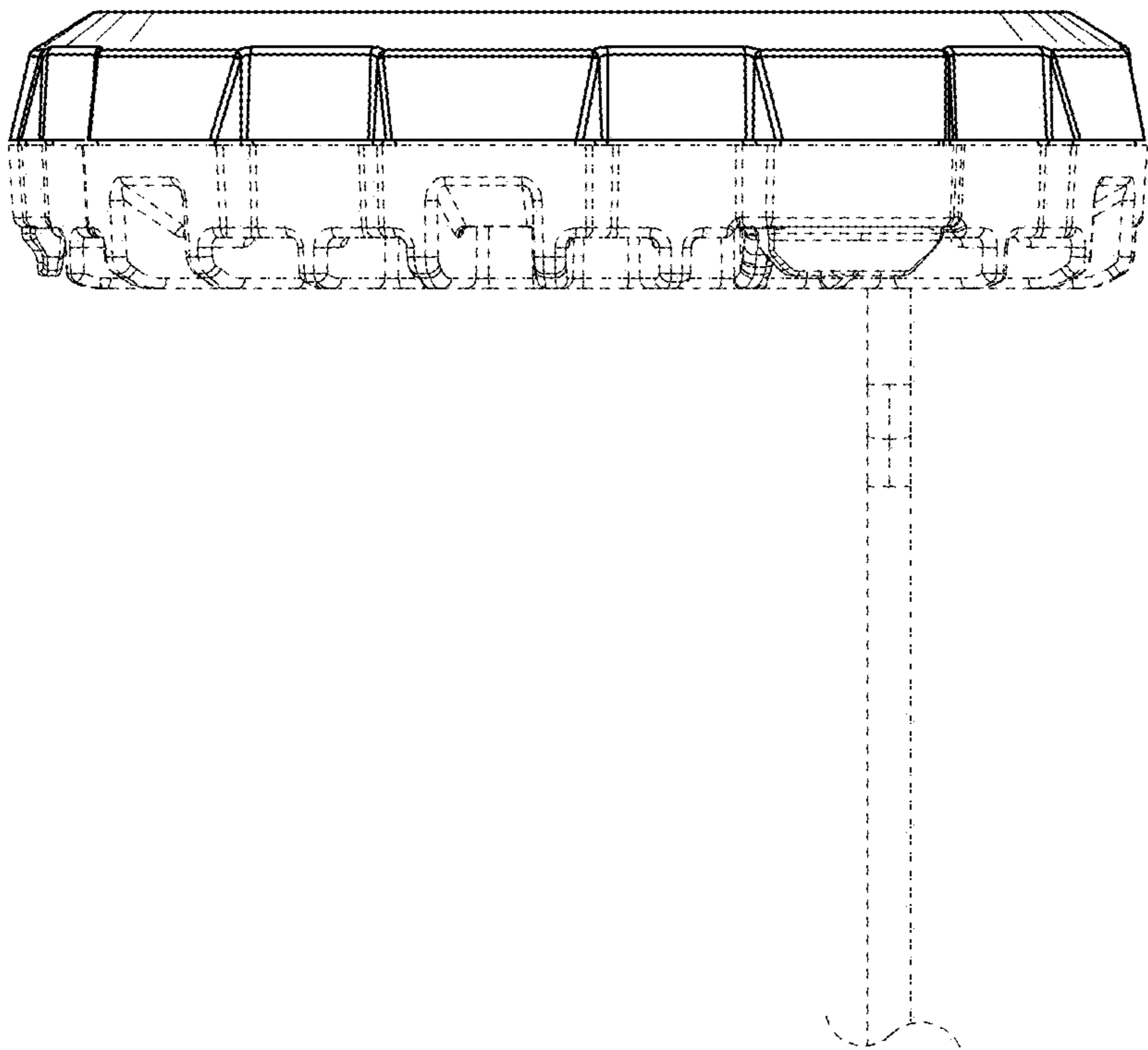

FIG. 7