



US00D968946S

(12) **United States Design Patent**
Comalander

(10) **Patent No.:** **US D968,946 S**

(45) **Date of Patent:** **** Nov. 8, 2022**

(54) **COMBINATION SADDLE AND INSERT FOR A PIPE SUPPORT SYSTEM**

(71) Applicant: **Comalander Fabrication and Services, LLC**, Beaumont, TX (US)

(72) Inventor: **Christopher R. Comalander**, Beaumont, TX (US)

(73) Assignee: **Comalander Fabrication and Services, LLC**, Beaumont, TX (US)

(**) Term: **15 Years**

(21) Appl. No.: **29/692,221**

(22) Filed: **May 23, 2019**

(51) **LOC (13) Cl.** **08-08**

(52) **U.S. Cl.**
USPC **D8/396**

(58) **Field of Classification Search**
USPC D8/394, 396, 349, 354, 383, 387
(Continued)

(56) **References Cited**

U.S. PATENT DOCUMENTS

2,310,434 A * 2/1943 Hyman F16L 3/04
248/71
2,681,196 A * 6/1954 Lind F16L 3/04
248/71

(Continued)

FOREIGN PATENT DOCUMENTS

CA 134054 * 10/2011

OTHER PUBLICATIONS

Drain Saddle 1/4" Push-in—naval bronze , first available N/A, freshwatersystem.com, [site visited Nov. 19, 2021], Available from internet URL: https://www.freshwatersystems.com/products/drain-saddle-1-4-push-in?variant=13250146238507&c1=GAW_SE_NW&source=PLA_USA_SS&cr2=shopping (Year: NA) (Year: NA).*

(Continued)

Primary Examiner — Omeed Agilee

Assistant Examiner — Rozita Mozaffarian

(74) *Attorney, Agent, or Firm* — Peter L. Brewer; Thrive IP

(57) **CLAIM**

The ornamental design for a combination saddle and insert for a pipe support system, as shown and described.

DESCRIPTION

FIG. 1 is a first perspective view of a combination saddle and insert for a pipe support system, showing my new design. FIG. 2 is a second perspective view thereof, showing the combination saddle and insert for a pipe support system in exploded-apart relation.

FIG. 3 is a front elevation view of the combination saddle and insert for a pipe support system of FIG. 1.

FIG. 4 is a rear elevation view thereof.

FIG. 5 is a right side elevation view thereof.

FIG. 6 is a left side elevation view thereof.

FIG. 7 is a top plan view thereof.

FIG. 8 is a bottom plan view thereof.

FIG. 9 is a first perspective view of the combination saddle and insert for a pipe support system, showing only the saddle.

FIG. 10 is a second perspective view thereof.

FIG. 11 is a front elevation view thereof.

FIG. 12 is a rear elevation view thereof.

FIG. 13 is a top plan view thereof.

FIG. 14 is a bottom plan view thereof.

FIG. 15 is a right side elevation view thereof.

FIG. 16 is a left side elevation view thereof.

FIG. 17 is a perspective view of the combination saddle and insert for a pipe support system, showing only the insert.

FIG. 18 is a front elevation view thereof.

FIG. 19 is a rear elevation view thereof.

FIG. 20 is a top plan view thereof.

FIG. 21 is a bottom plan view thereof.

FIG. 22 is a right side elevation view thereof; and,

FIG. 23 is a left side elevation view thereof.

(Continued)

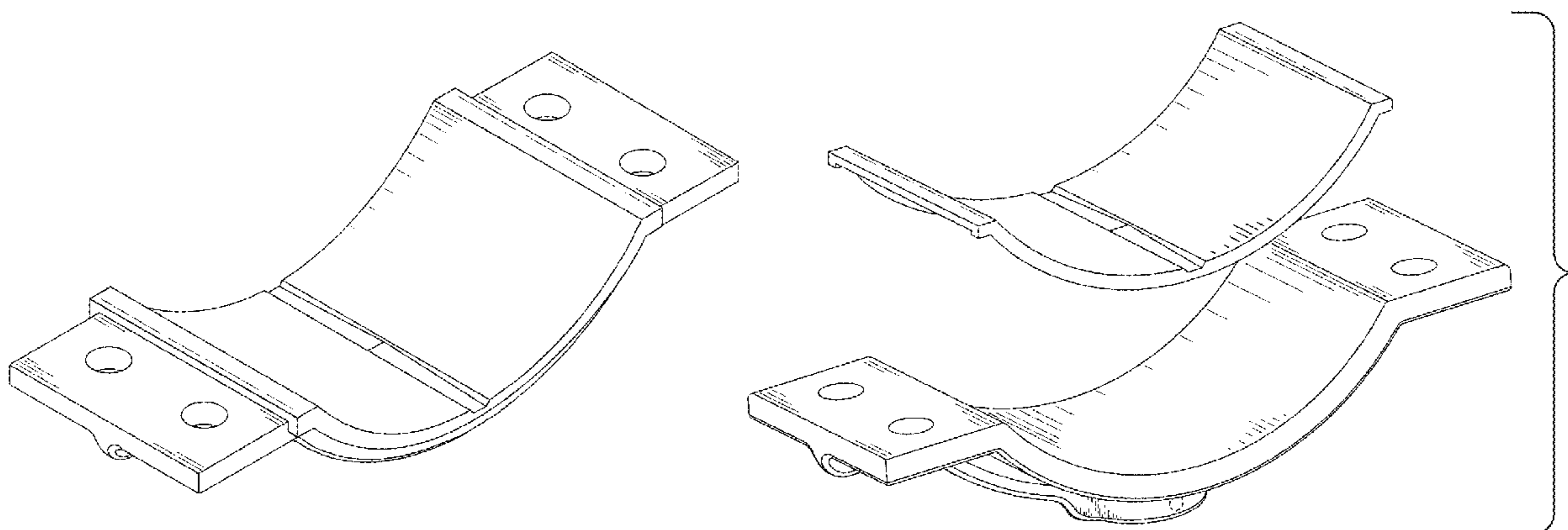

The broken lines in the drawings depict portions of the saddle for the combination saddle and insert for a pipe support system that form no part of the claimed designs.

1 Claim, 8 Drawing Sheets

(58) Field of Classification Search

CPC ... F16L 1/0246; F16L 3/18; F16L 3/16; F16L 3/1091; F16L 55/07; F16B 2/065; F16B 5/065; F16B 35/005; F16B 5/0628; F16B 21/16

See application file for complete search history.

(56) References Cited

U.S. PATENT DOCUMENTS

4,789,189	A	12/1988	Robertson	
7,090,173	B2 *	8/2006	Lussier	F16L 3/11 248/58
7,497,405	B2	3/2009	Huo	
D634,817	S *	3/2011	Madara	D23/262
D649,267	S *	11/2011	Apgood, II	D25/138
D651,290	S *	12/2011	Shah	D23/262
D684,034	S *	6/2013	Vaughan	D8/354
8,807,492	B2	8/2014	Lake	
9,046,197	B2	6/2015	Cousineau	
D742,213	S *	11/2015	Sasanecki	D8/396

D756,212	S *	5/2016	Wilk, Jr.	D8/396
9,458,951	B2	10/2016	Haynes et al.	
D805,888	S *	12/2017	De Los Santos	D8/396
10,221,968	B2	3/2019	Haynes et al.	
10,274,111	B2	4/2019	Breda	
10,501,189	B2 *	12/2019	Malligere	F16B 2/10
D892,596	S *	8/2020	Farnworth	D8/354
2005/0242585	A1 *	11/2005	Dole	F16L 21/065 285/367
2017/0276261	A1 *	9/2017	Hargrave	F16L 55/041
2018/0335165	A1 *	11/2018	Anderson	F16L 3/1075
2020/0318760	A1 *	10/2020	Comalander	F16L 1/0246
2020/0347963	A1 *	11/2020	Ohnemus	F16L 3/1091

OTHER PUBLICATIONS

Screen Shot of Pipe Saddles & Coverings; Accessed May 2019; Date of publication unknown; <https://pipingtech.com/products/pipe-supports-hangers/pipe-saddles-coverings/>; pp. 5.

Screen Shot of Pipe Insulation Protection Shield; Accessed May 2019; Date of publication unknown; <https://pipingtech.com/products/pipe-supports-hangers/pipe-saddles-coverings/#spec-jump>; pp. 5.

Screen Shot of Pipe Hangers & Supports: Pipe Saddles & Stanchions; Accessed May 2019; Date of publication unknown; <https://taylorpipesupports.ca/products/pipe-hangers-supports/pipe-saddles-stanchions.php>; pp. 6.

Screen Shot of Pipe Saddles & Shields; Accessed May 2019; Date of publication unknown; <http://www.pipesupports.com/products/witch-commodity-hardware/3>; pp. 6.

* cited by examiner

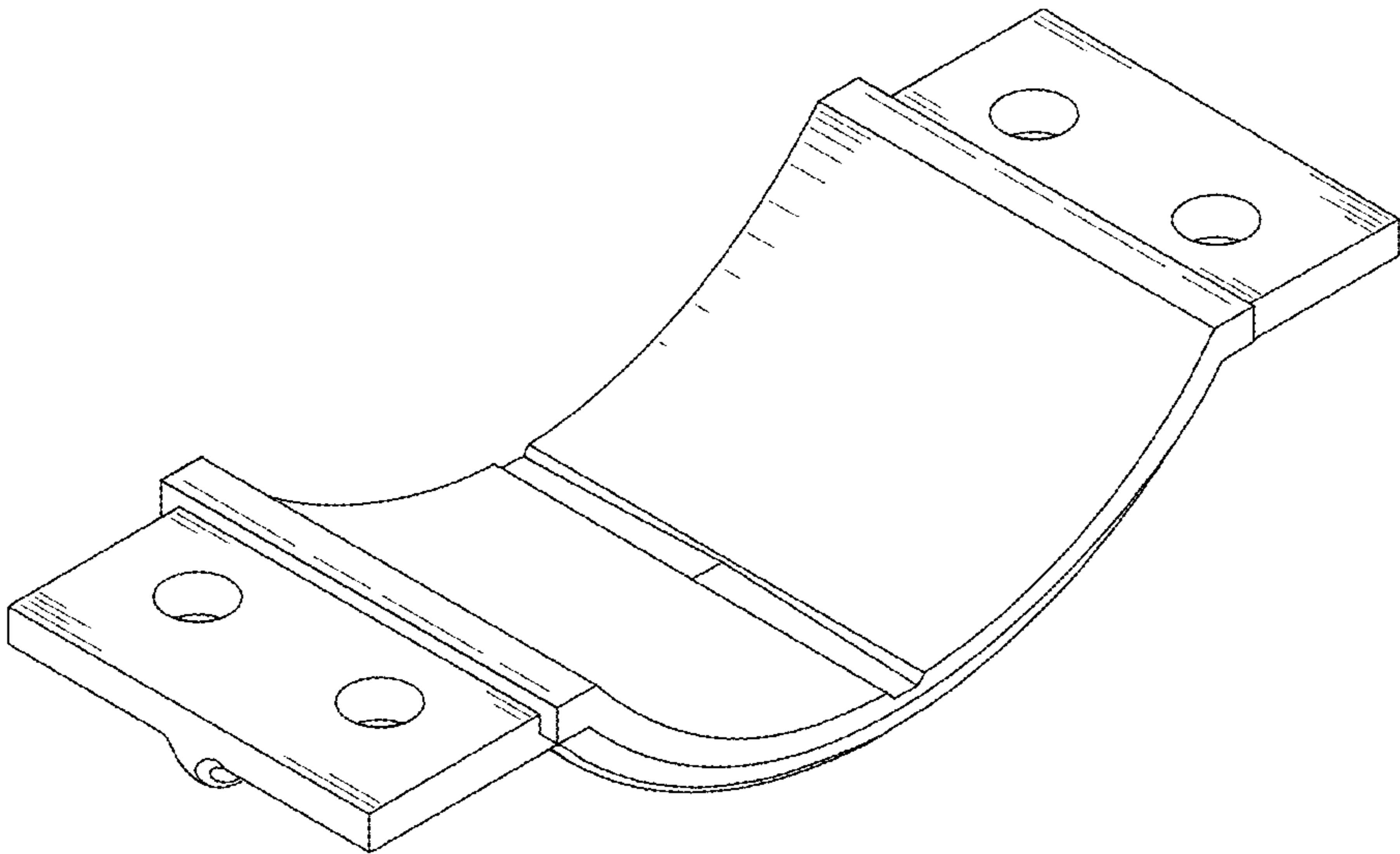

FIG. 1

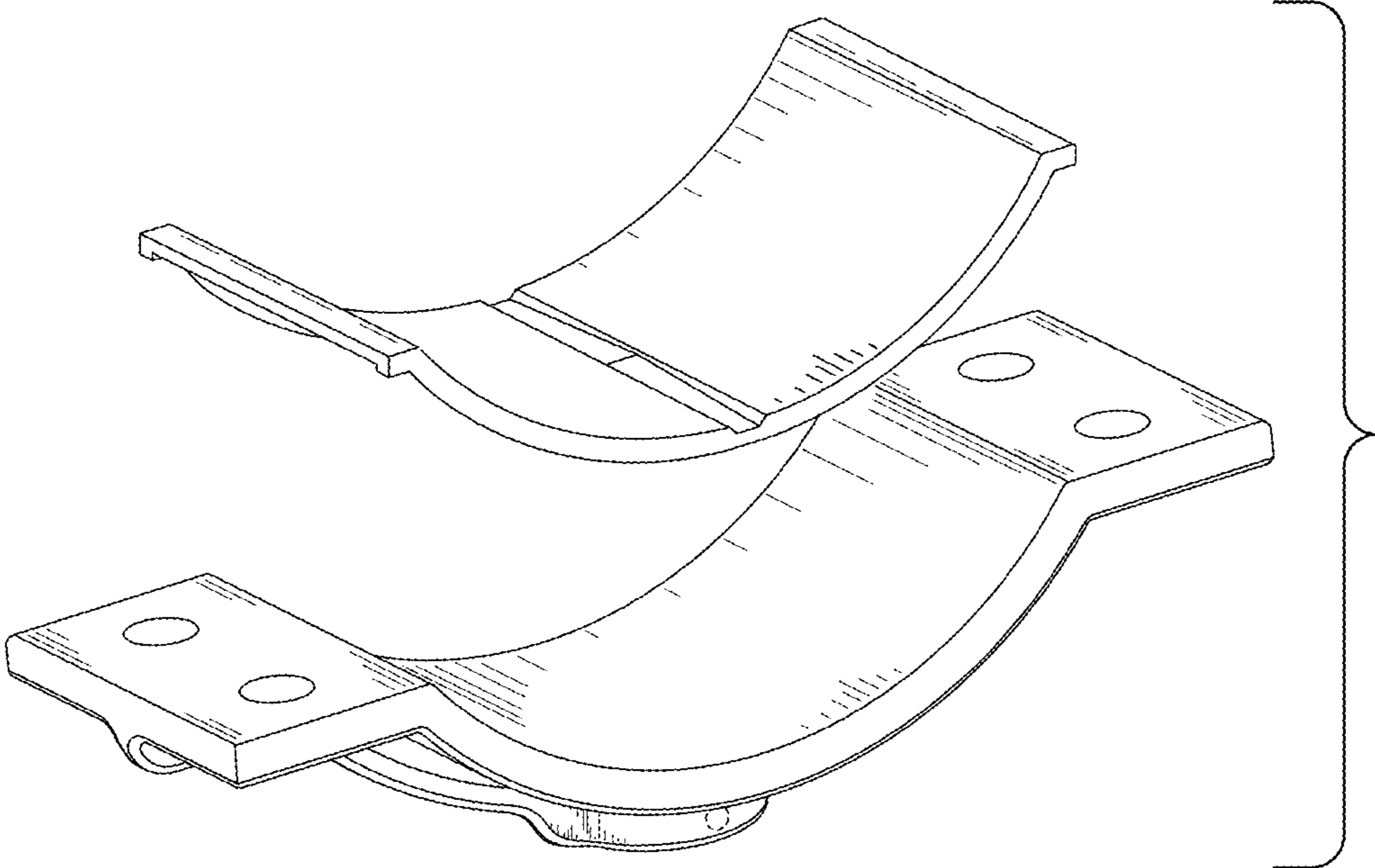

FIG. 2

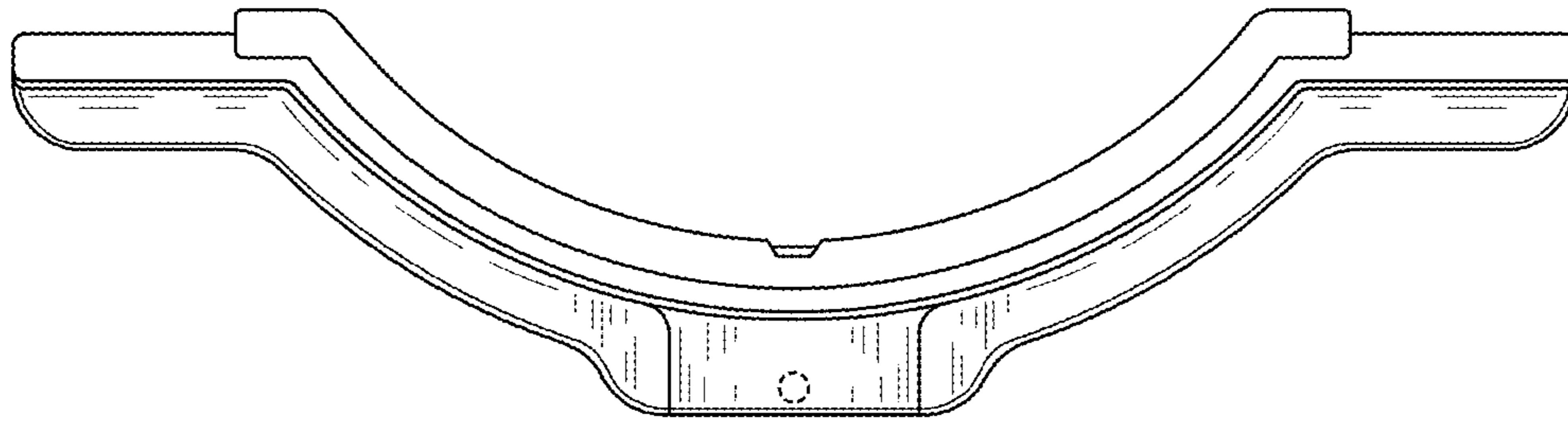

FIG. 3

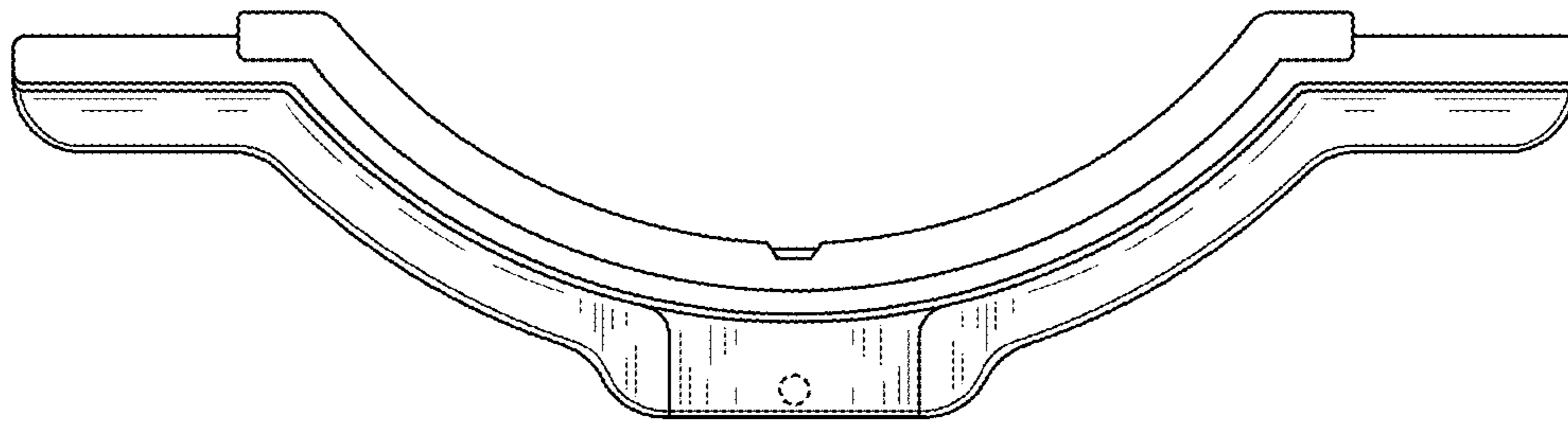

FIG. 4

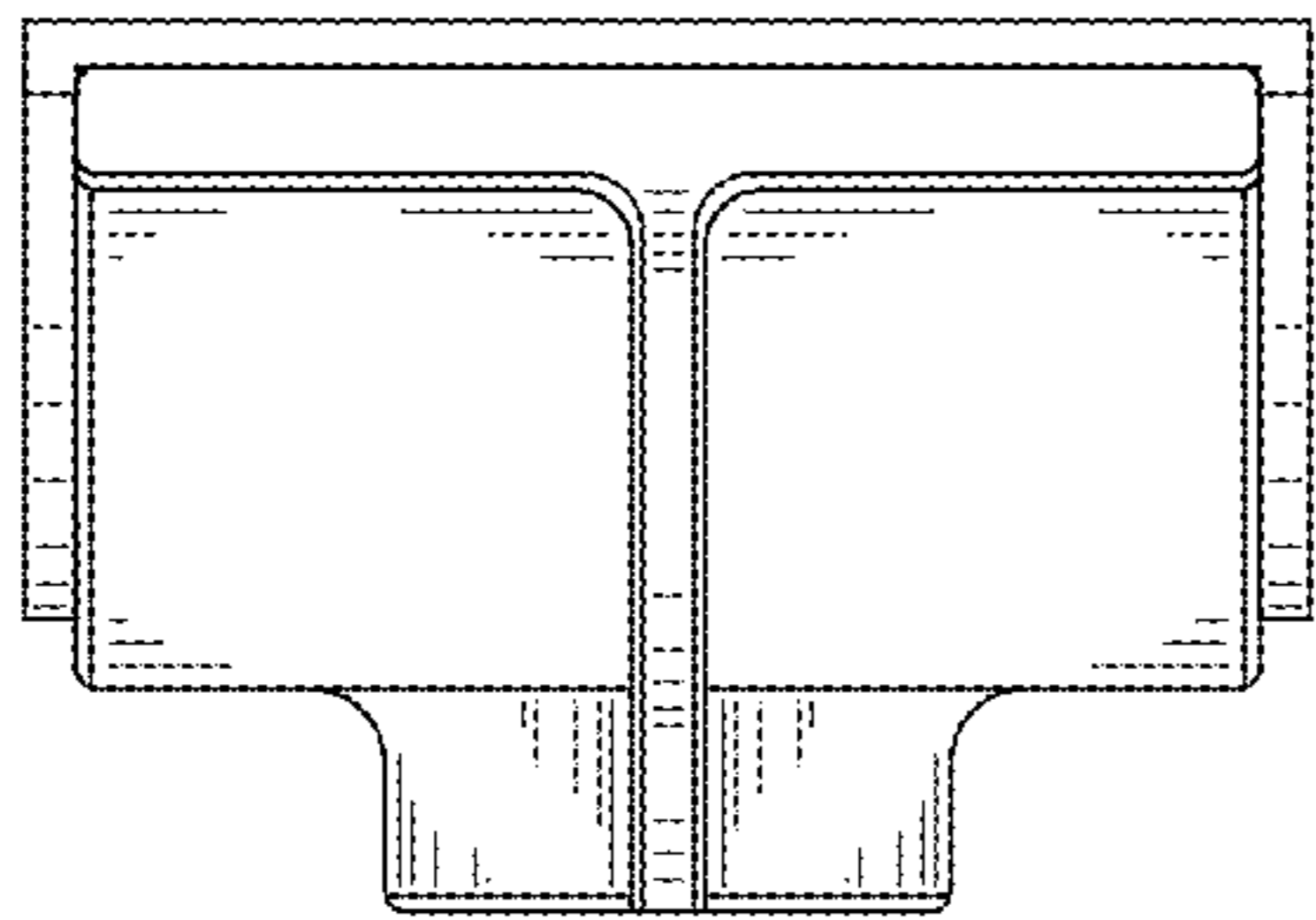

FIG. 5

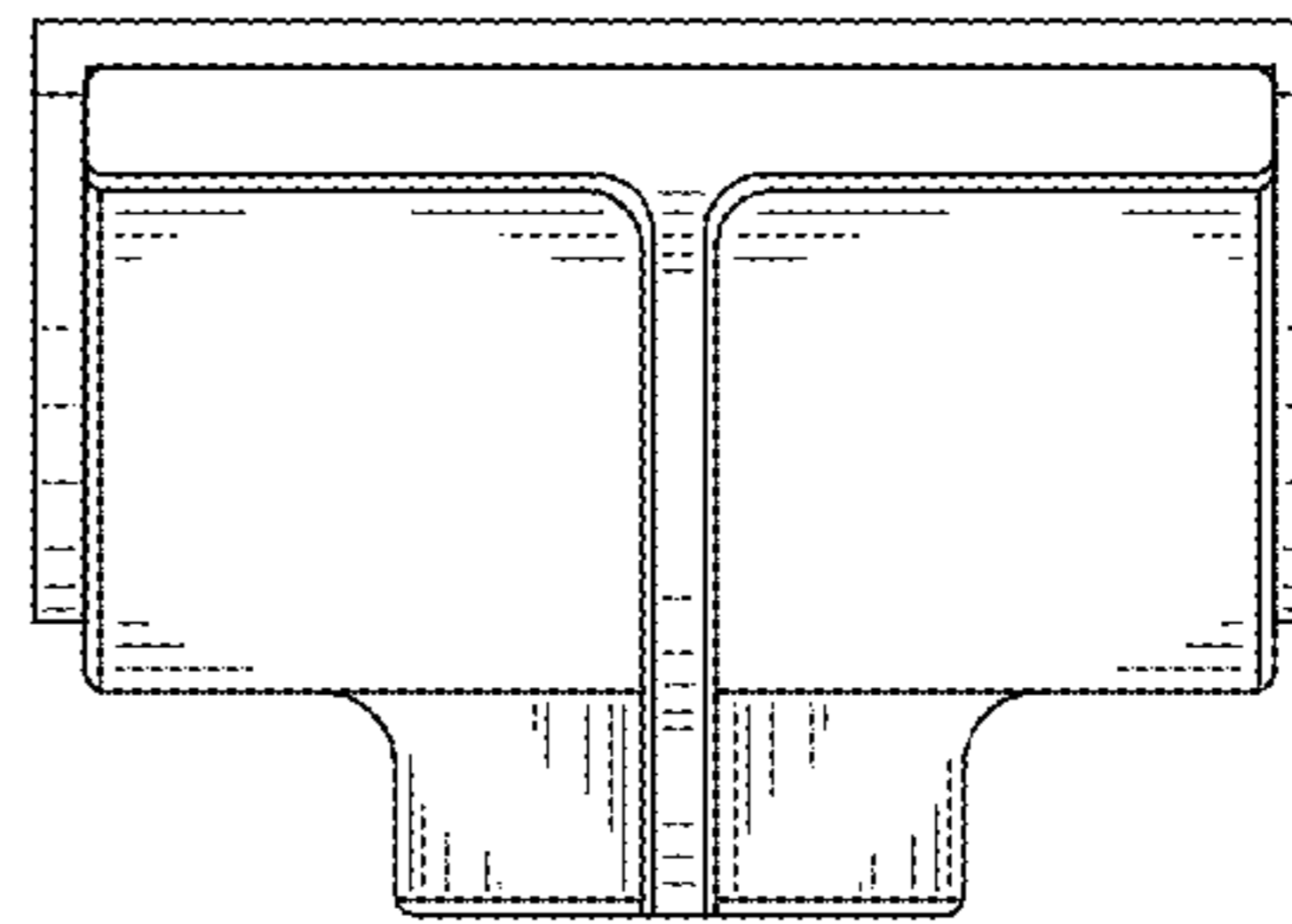

FIG. 6

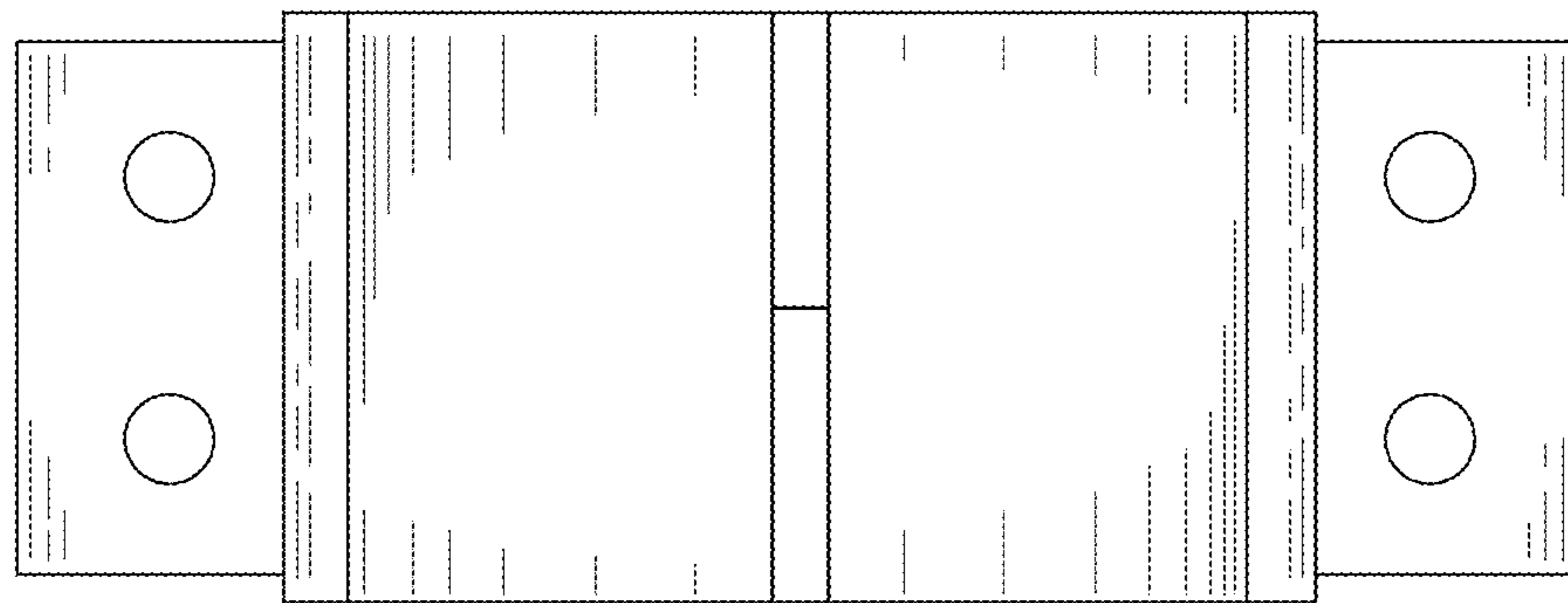

FIG. 7

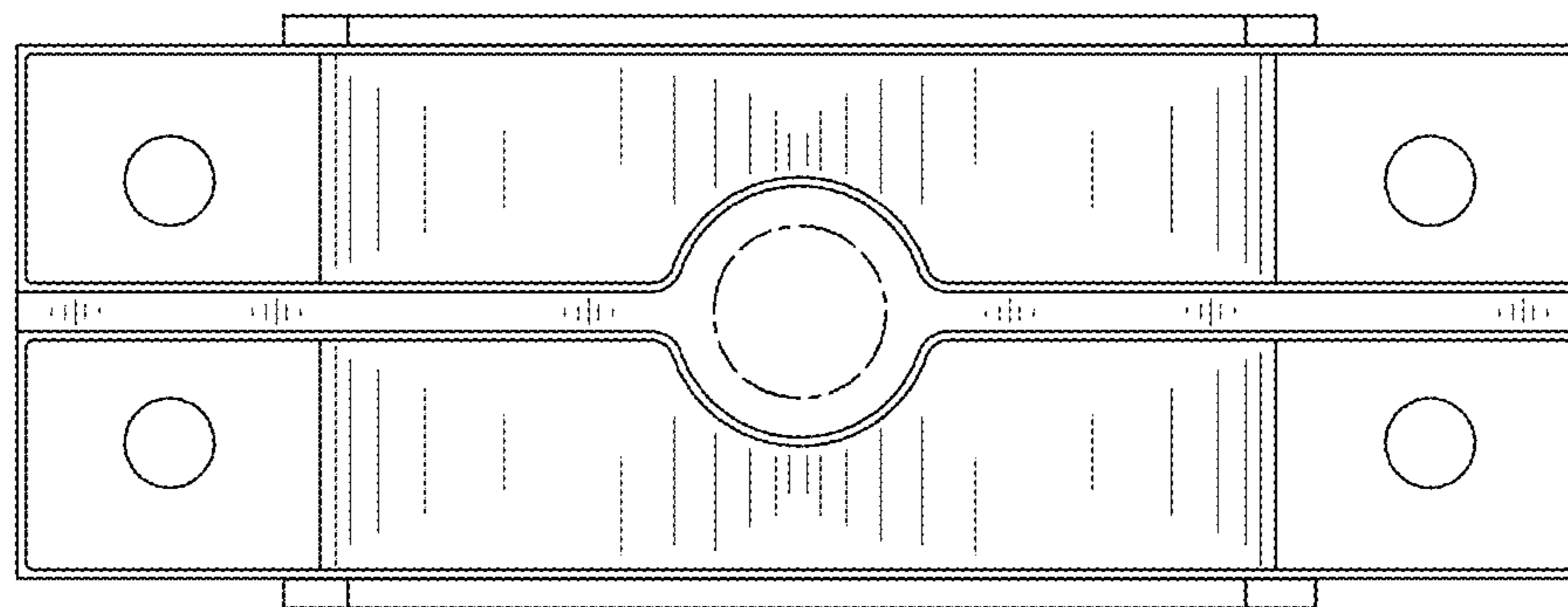

FIG. 8

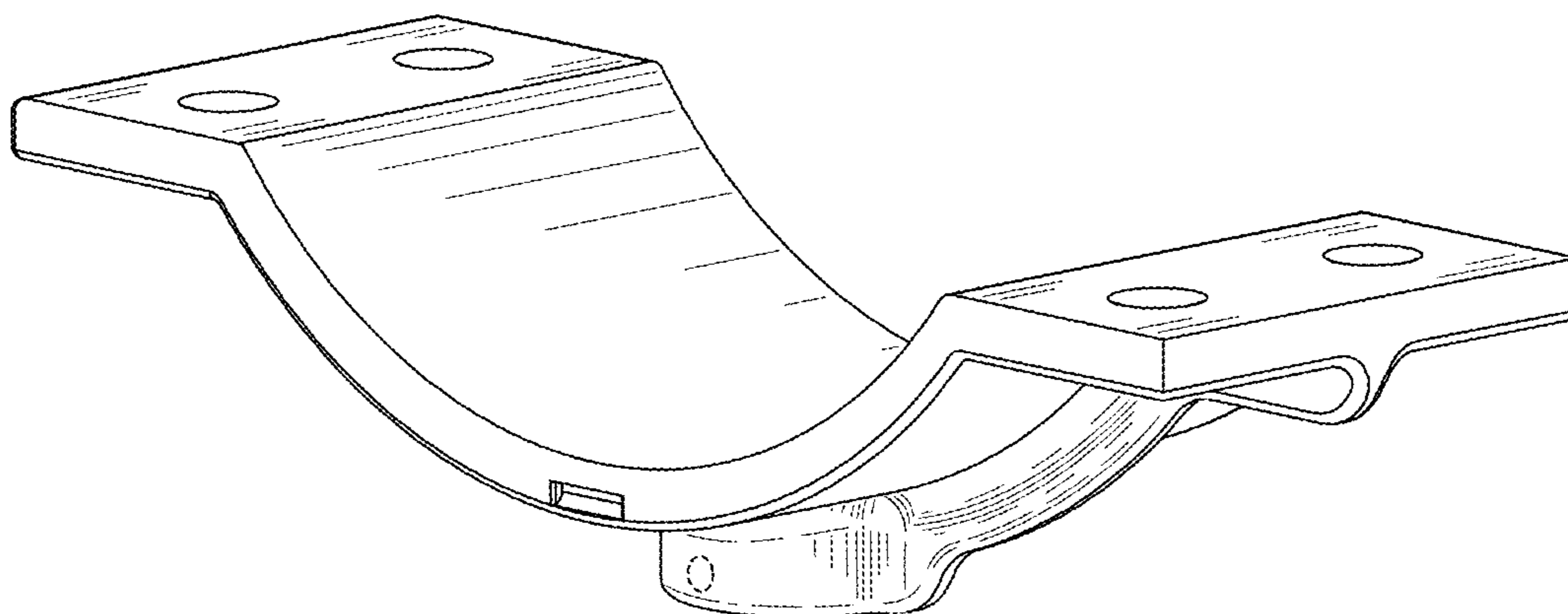

FIG. 9

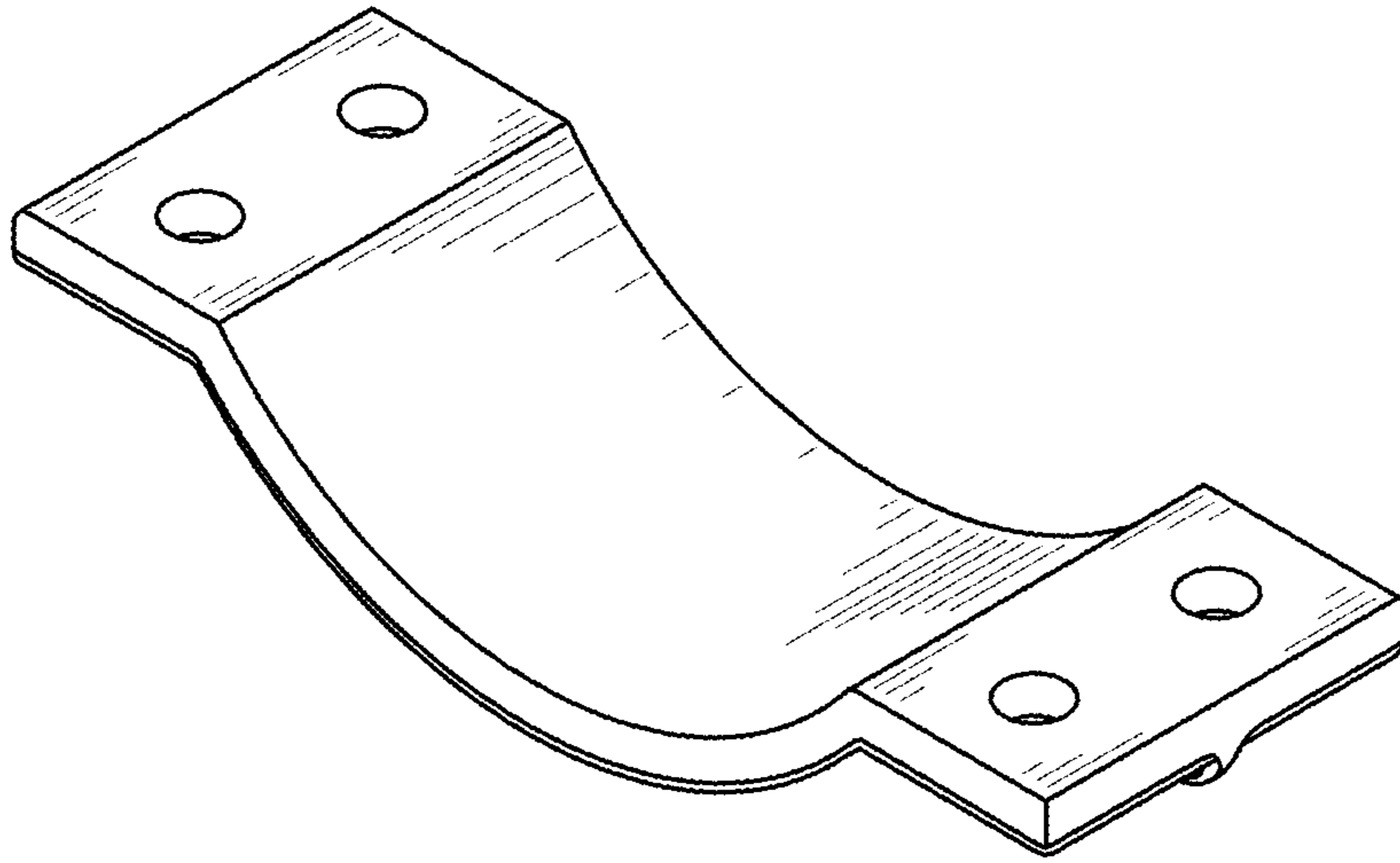

FIG. 10

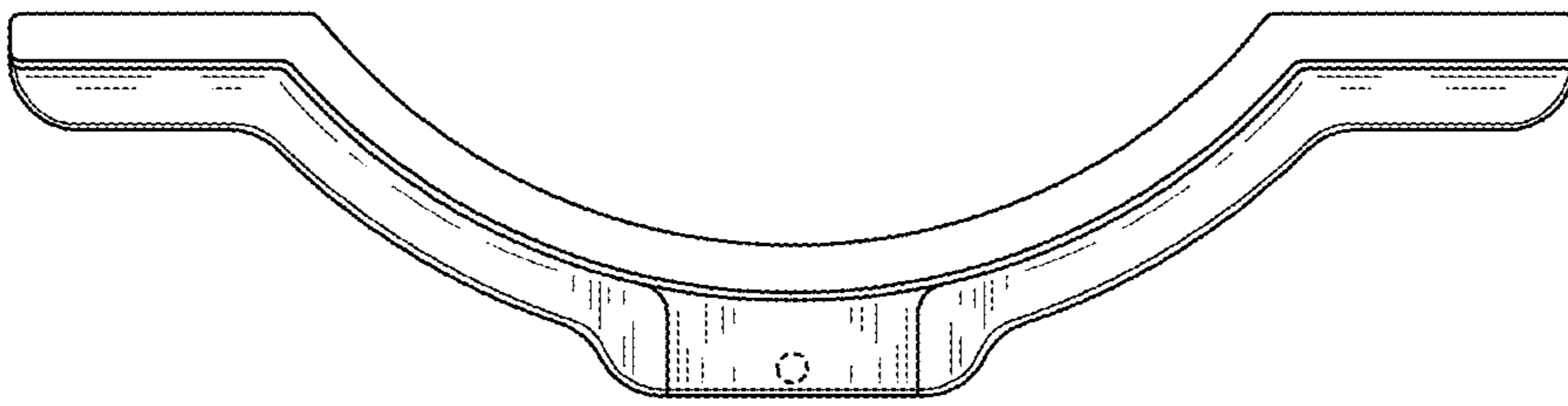

FIG. 11

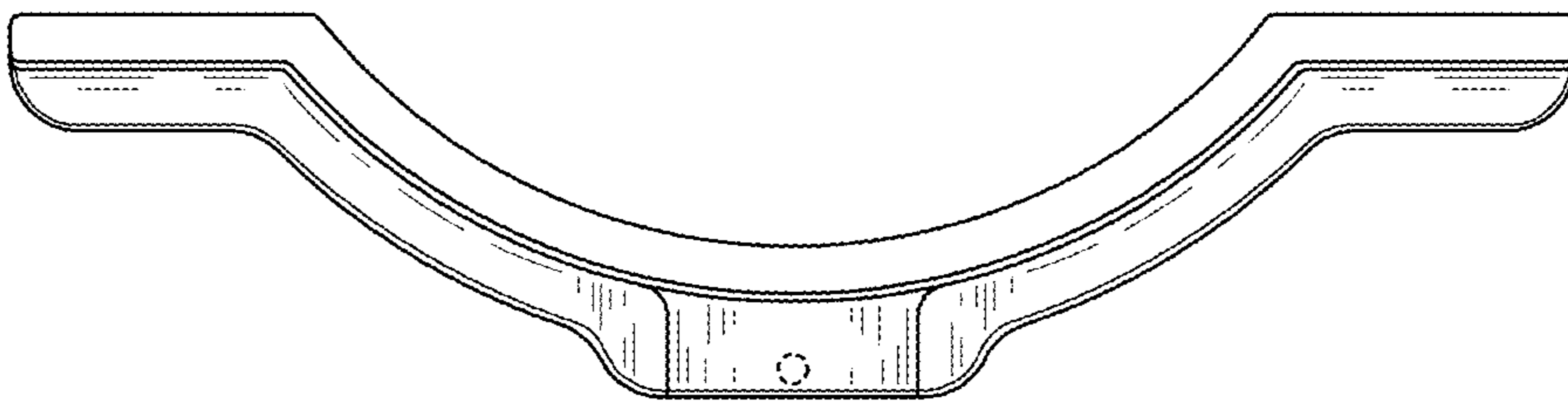

FIG. 12

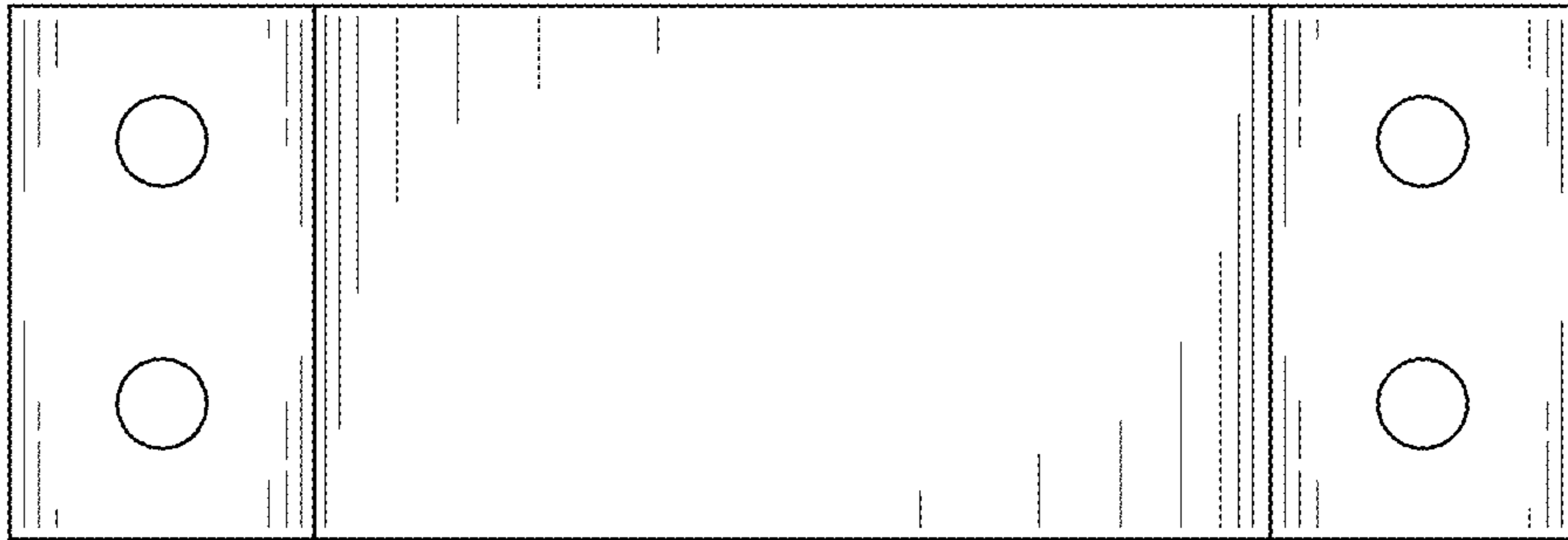

FIG. 13

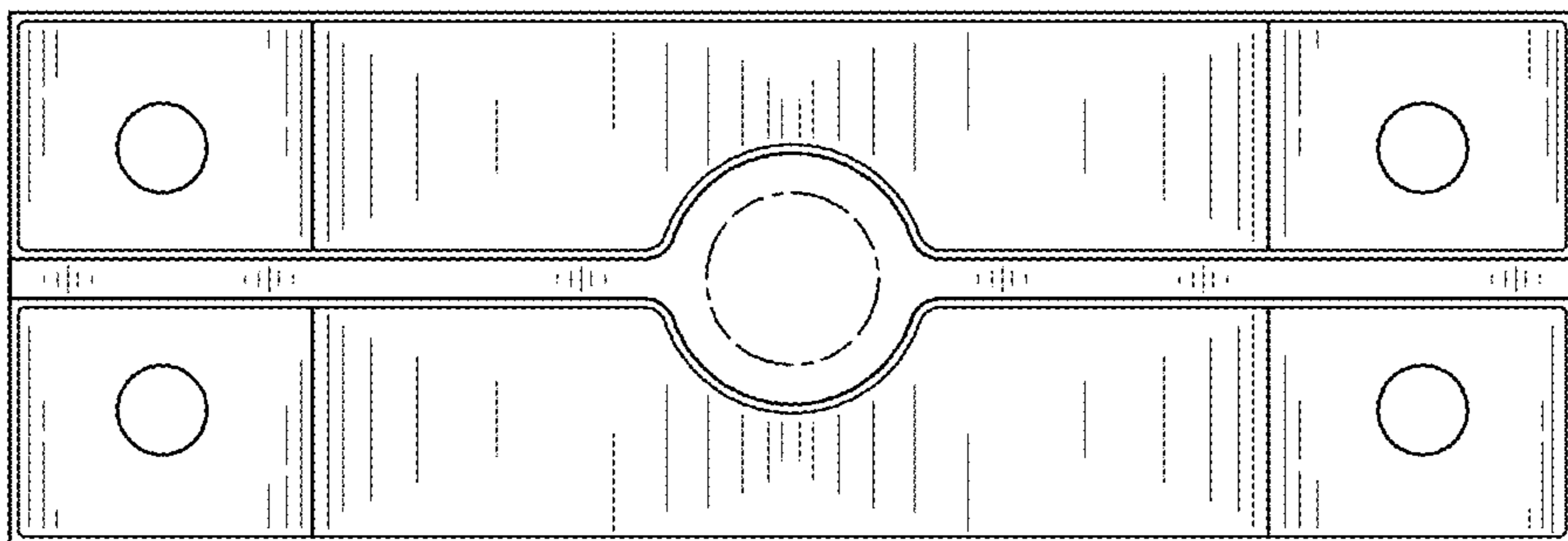

FIG. 14

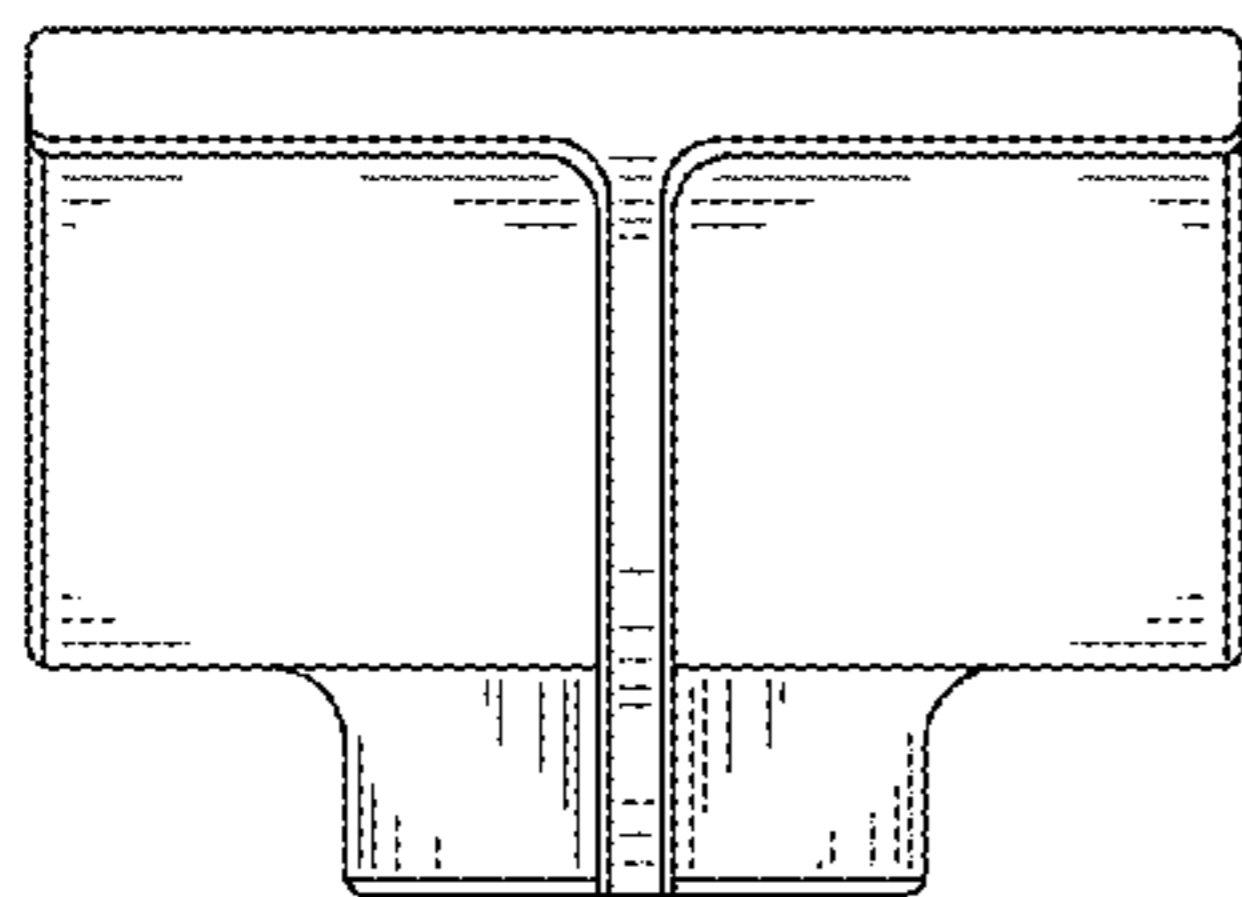

FIG. 15

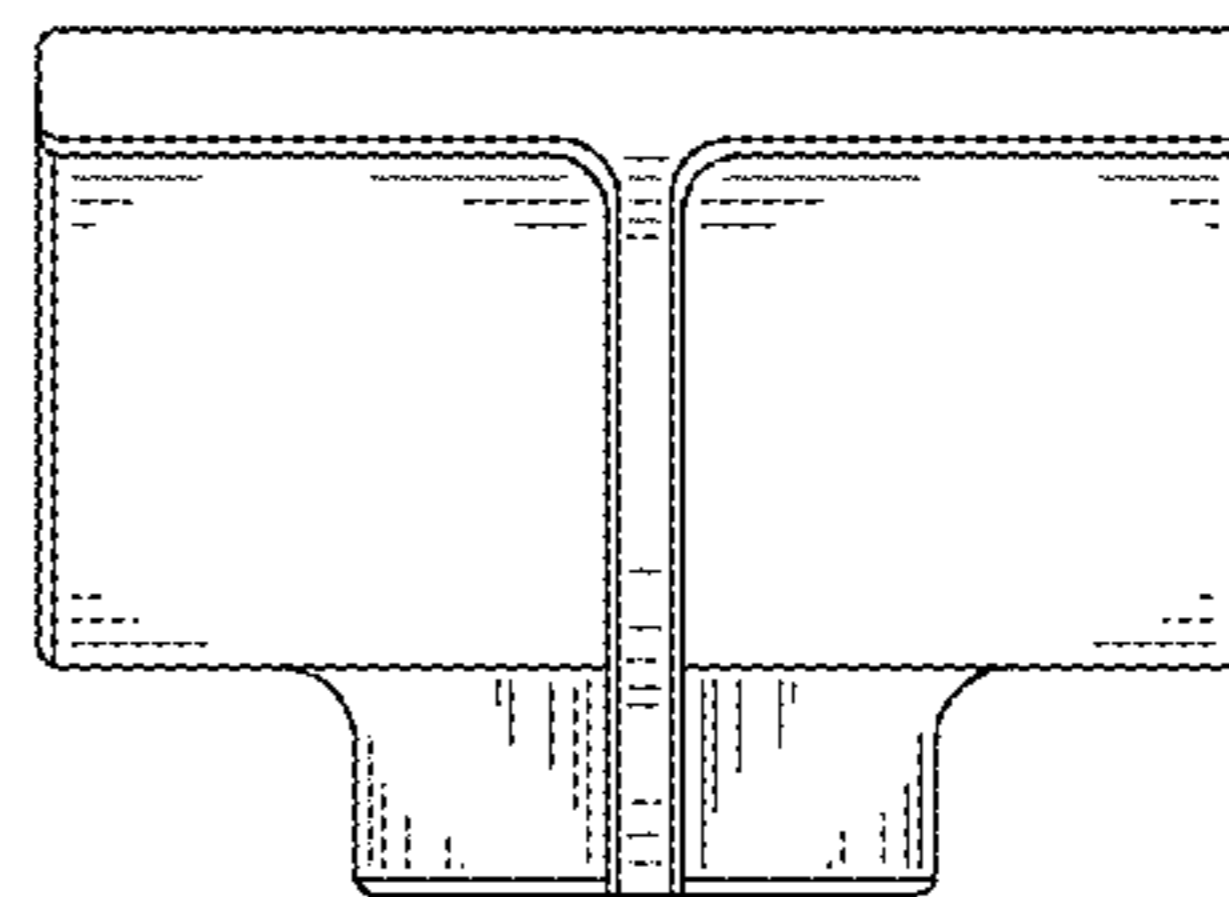

FIG. 16

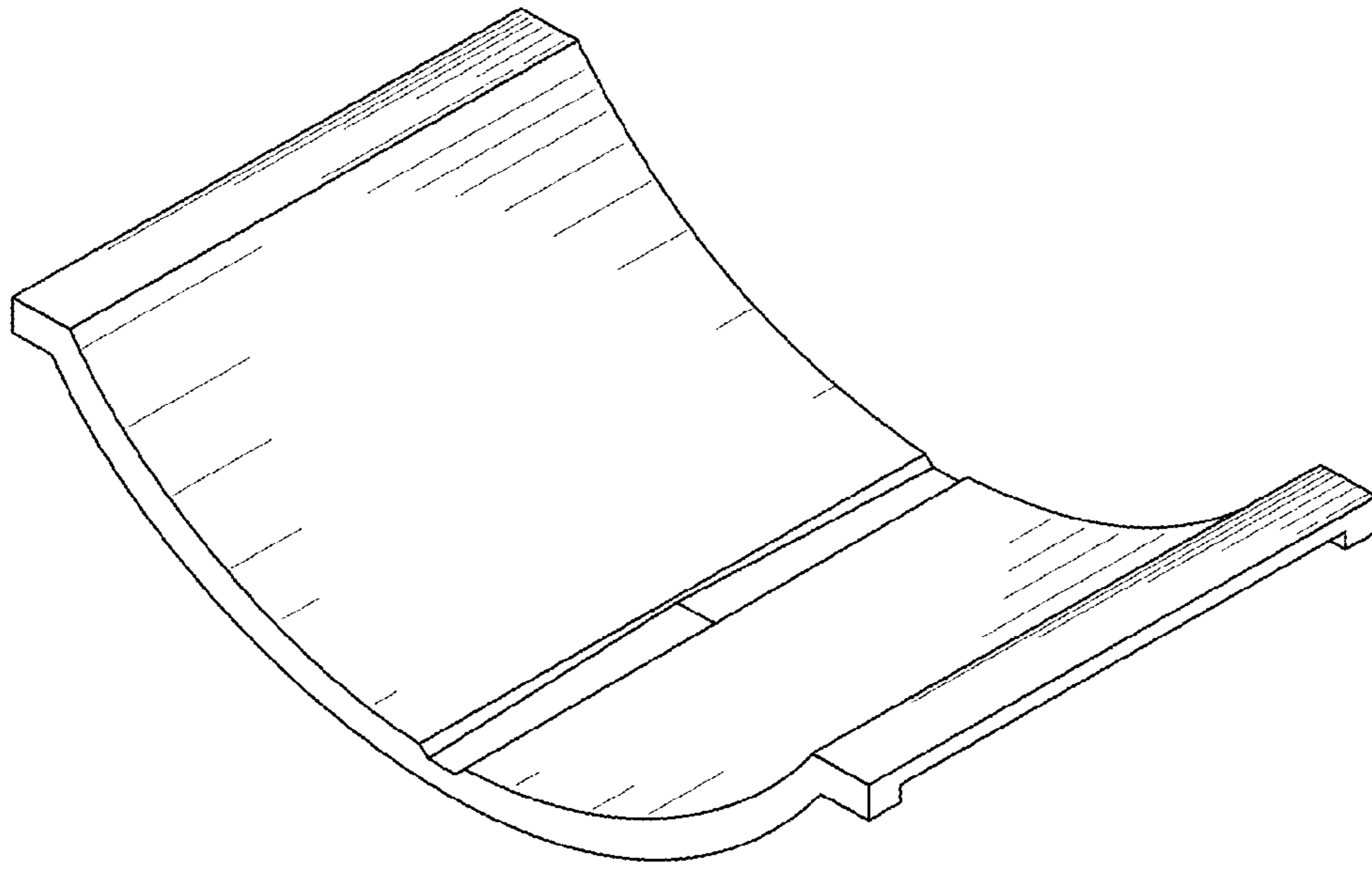

FIG. 17

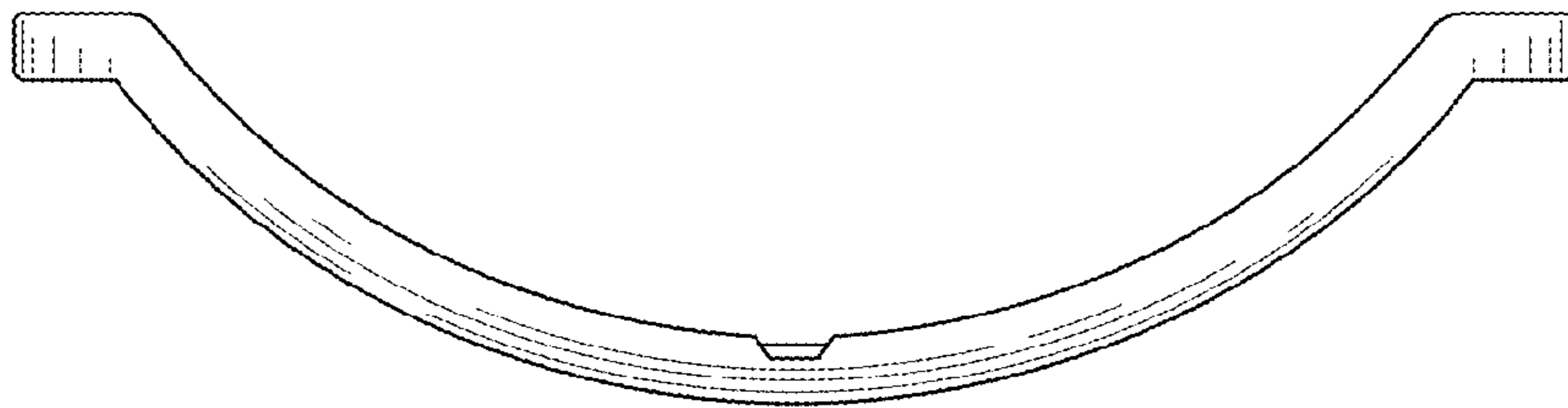

FIG. 18

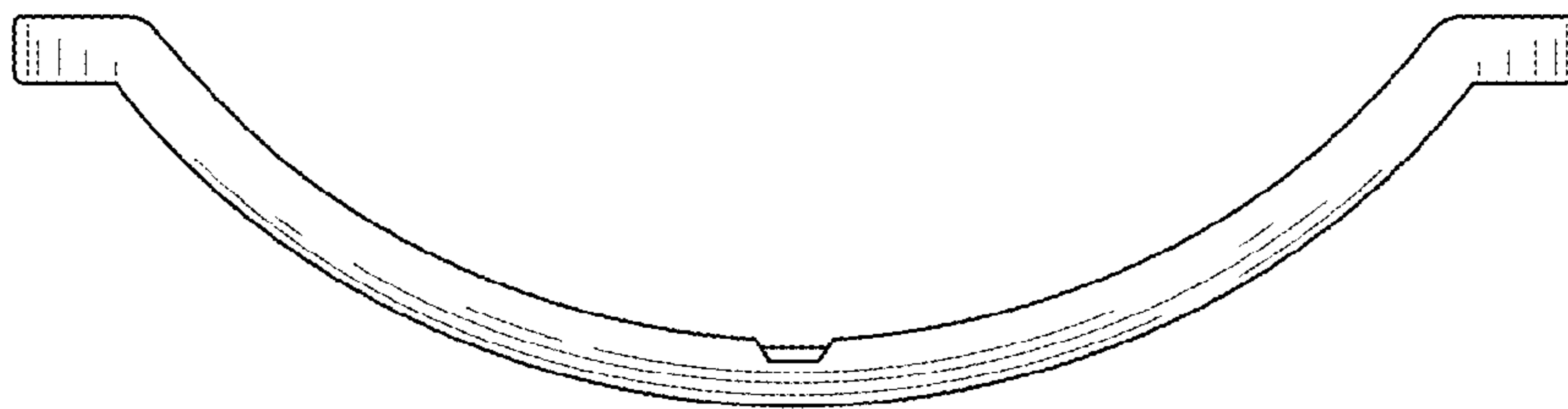

FIG. 19

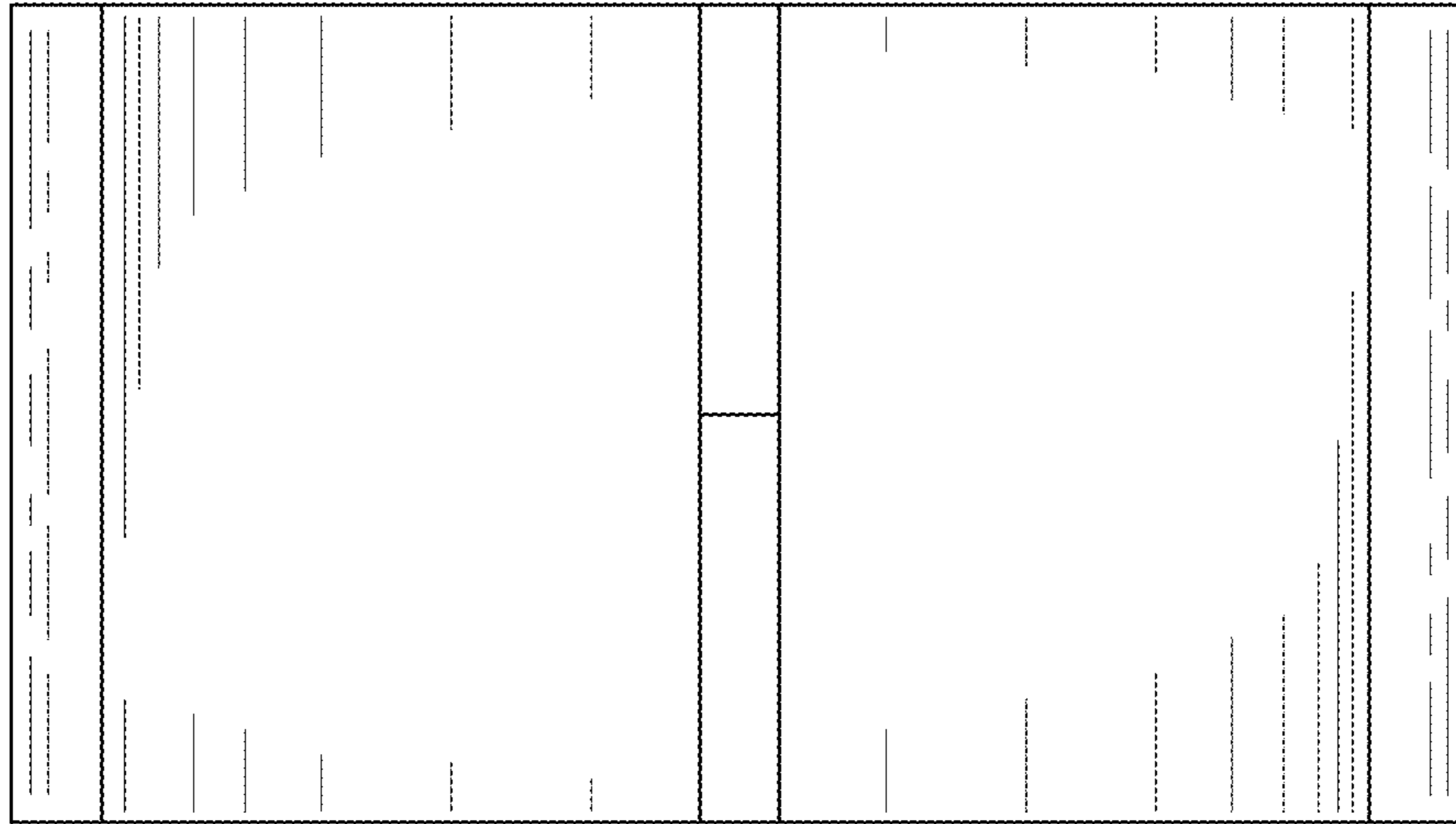

FIG. 20

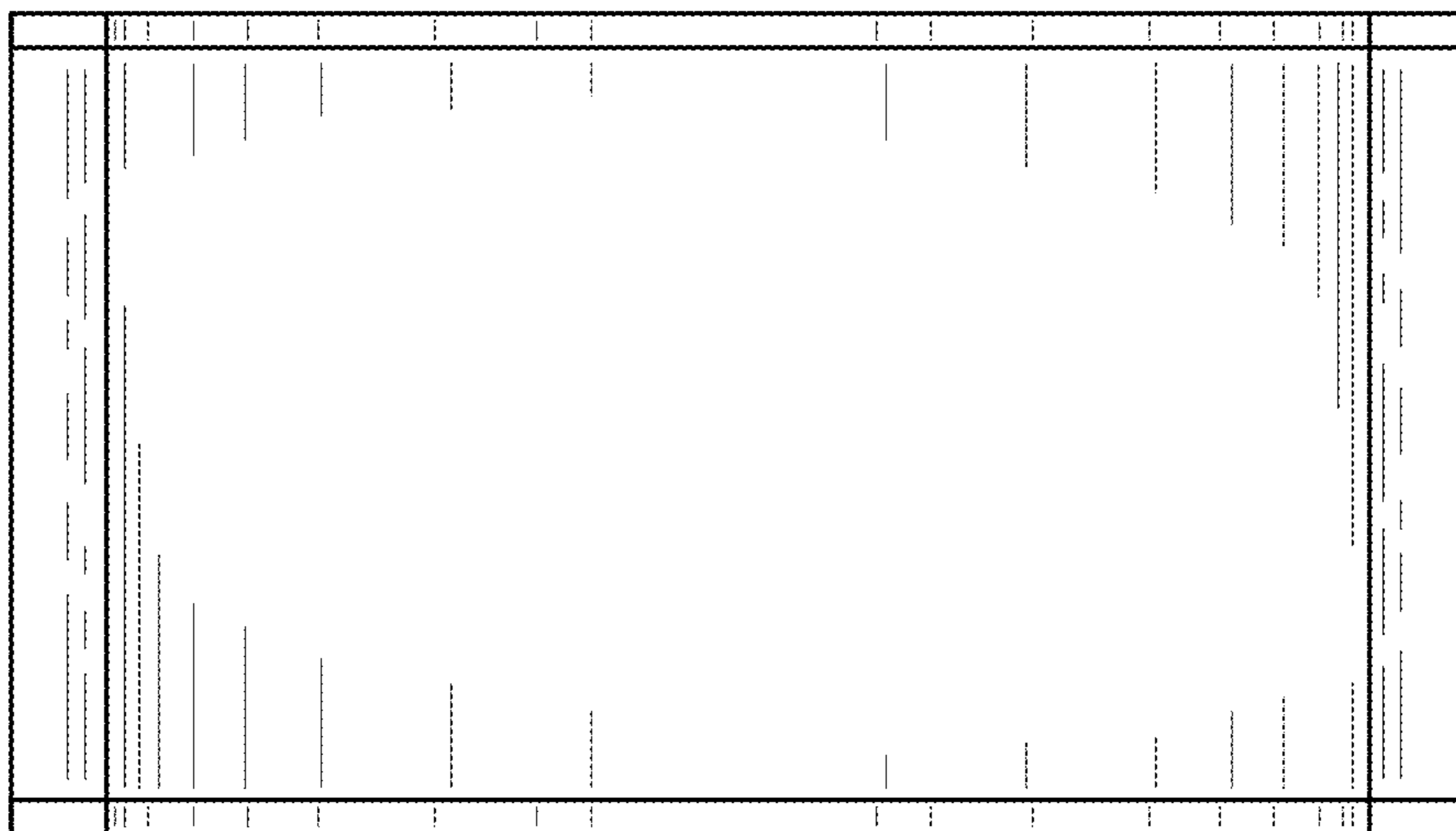

FIG. 21

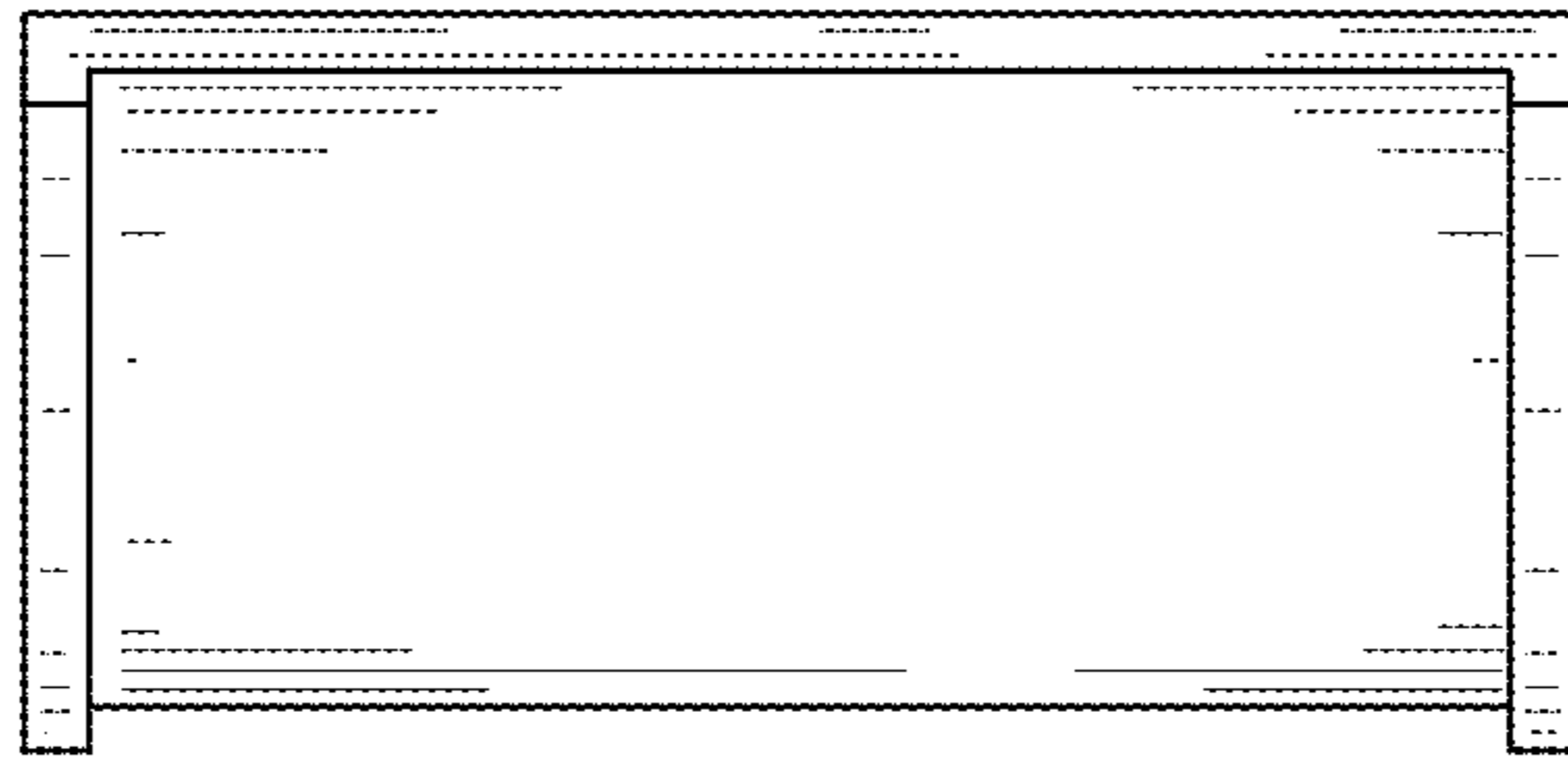

FIG. 22

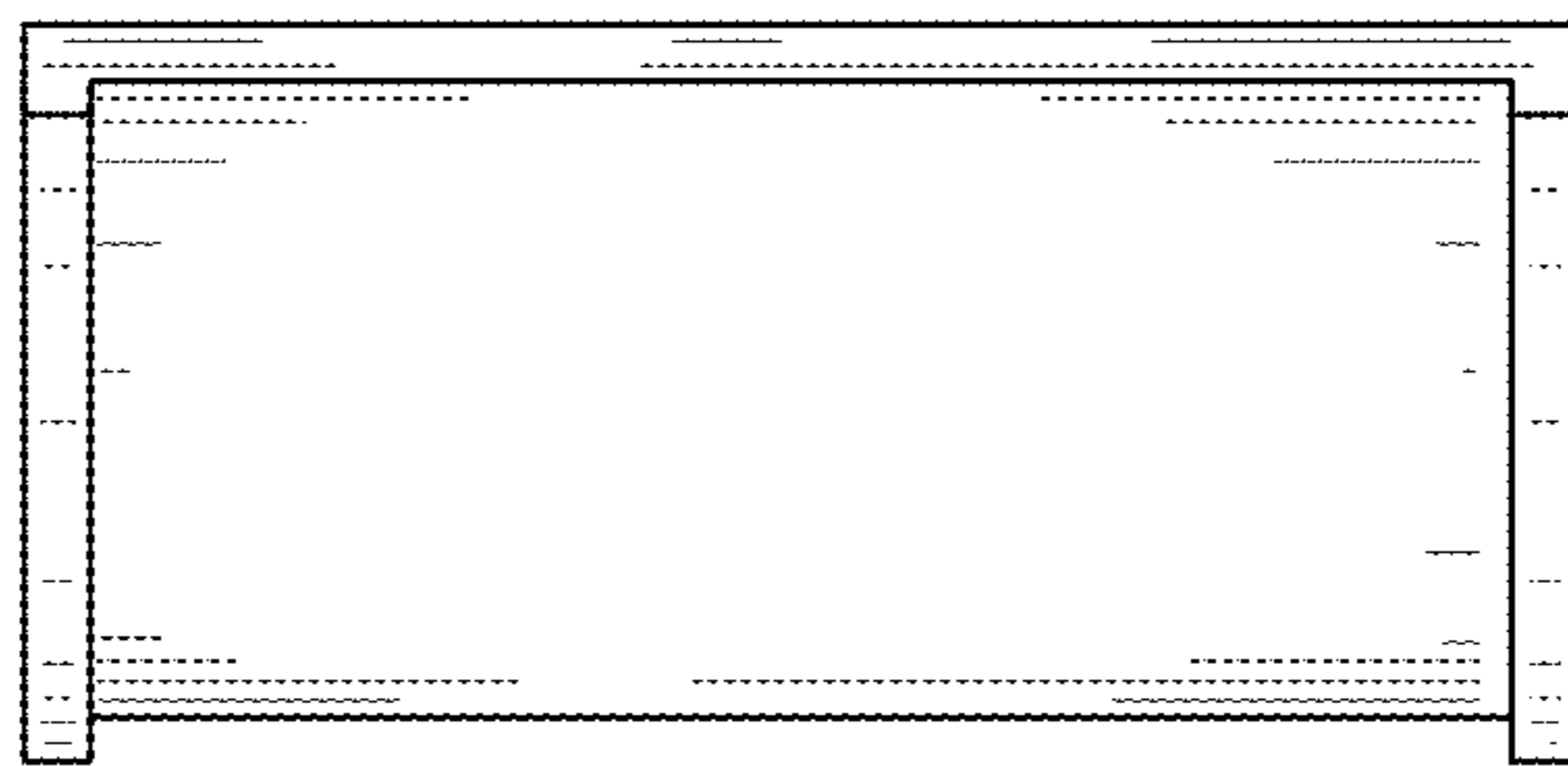

FIG. 23