



US00D968736S

(12) **United States Design Patent** (10) **Patent No.:** **US D968,736 S**  
**Lange** (45) **Date of Patent:** **\*\* Nov. 1, 2022**

(54) **WATER TANK FOR VACUUM CLEANER** 3,064,292 A \* 11/1962 Fillery ..... A47L 11/40  
15/385

(71) Applicant: **GLUTTON CLEANING MACHINES** 4,559,665 A \* 12/1985 Fitzwater ..... A47L 11/34  
SA, Andenne (BE) D32/22

(72) Inventor: **Christian Lange, Ohey (BE)** D285,739 S \* 9/1986 Cavalli ..... D32/73  
D292,537 S \* 10/1987 Alfredo ..... D32/73  
D292,837 S \* 11/1987 Alfredo ..... D32/73

(\*\*) Term: **15 Years** D314,460 S \* 2/1991 Paulin ..... D23/209  
5,054,160 A \* 10/1991 Marino ..... A47L 9/06  
D32/31

(21) Appl. No.: **35/512,072** 5,507,068 A \* 4/1996 Fan ..... A47L 11/4061  
D32/18

(22) Filed: **Apr. 26, 2021** D460,229 S \* 7/2002 Zahuranec ..... D32/22  
D728,179 S \* 4/2015 Yoon ..... D32/31

(80) **Hague Agreement Data** D913,613 S \* 3/2021 Kim ..... D32/10  
D917,815 S \* 4/2021 Kim ..... D32/31  
D926,400 S \* 7/2021 Kim ..... D32/21

Int. Filing Date: **Apr. 26, 2021**  
Int. Reg. No.: **DM/214800**  
Int. Reg. Date: **Apr. 26, 2021**  
Int. Reg. Pub. Date: **Jun. 25, 2021**

\* cited by examiner

*Primary Examiner* — Richard E Chilcot

(30) **Foreign Application Priority Data**

Oct. 30, 2020 (EM) ..... 008221352-0001

(51) **LOC (13) Cl.** ..... **15-05**

(52) **U.S. Cl.**  
USPC ..... **D32/31**  
CPC ..... **A47L 11/24 (2013.01)**

(58) **Field of Classification Search**  
USPC ..... D32/31-33, 15, 17, 18, 21-24  
CPC .. A47L 11/24; A47L 11/4005; A47L 11/4066;  
A47L 2201/00; A47L 9/009  
See application file for complete search history.

(56) **References Cited**

**U.S. PATENT DOCUMENTS**

2,986,764 A \* 6/1961 Krammes ..... A47L 11/4008  
15/345

2,989,769 A \* 6/1961 Houser ..... A47L 7/0038  
15/353

(57) **CLAIM**

The ornamental design for a water tank for a vacuum cleaner, as shown and described.

**DESCRIPTION**

Figure 1.1 is a perspective view from above and the right of a water tank for a vacuum cleaner showing our new design; Figure 1.2 is a front elevational view thereof; Figure 1.3 is rear elevational view thereof; Figure 1.4 is a left side elevational view thereof; Figure 1.5 is a top plan view thereof; and Figure 1.6 is a bottom plan view thereof.

**1 Claim, 5 Drawing Sheets**

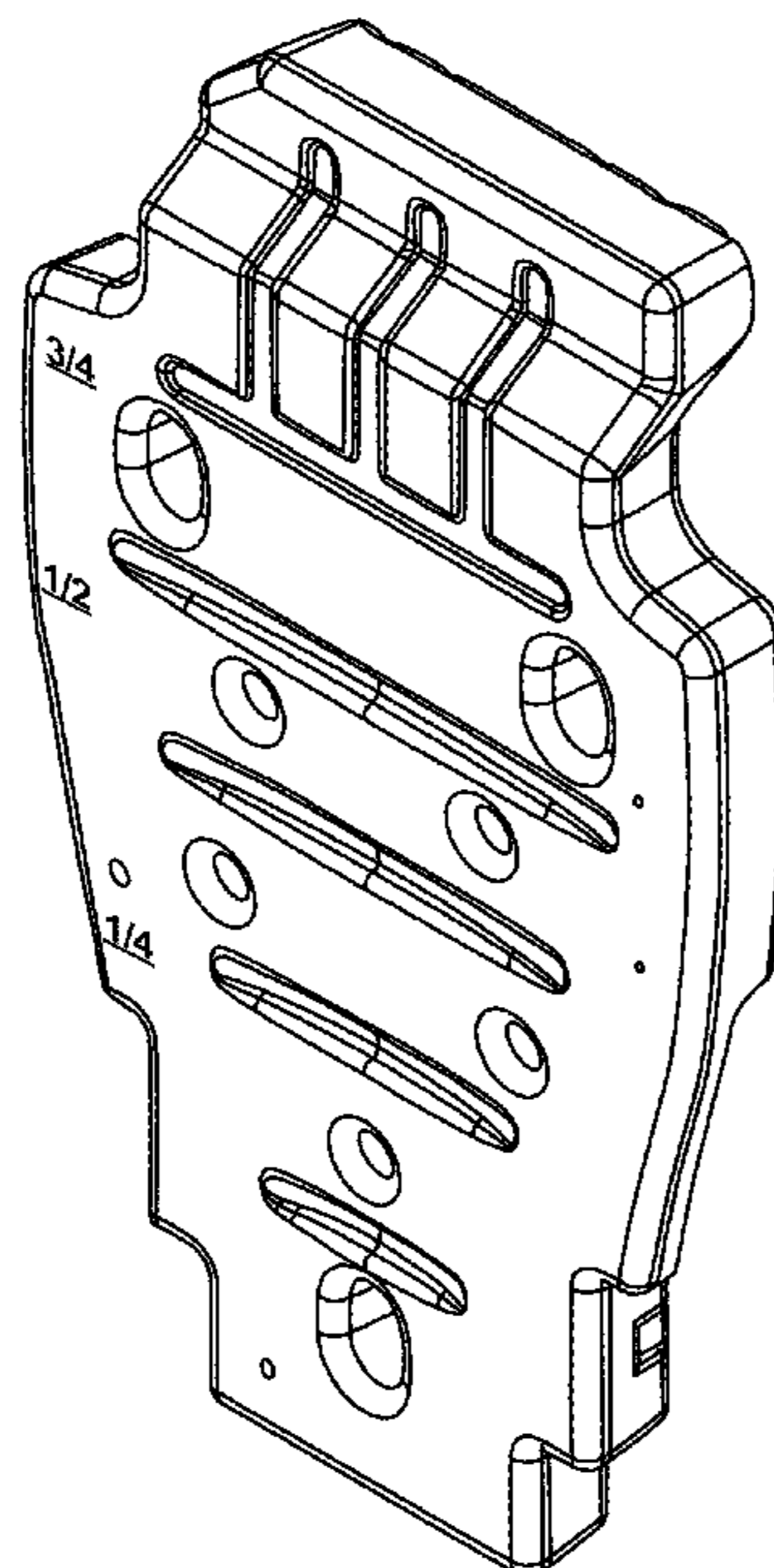

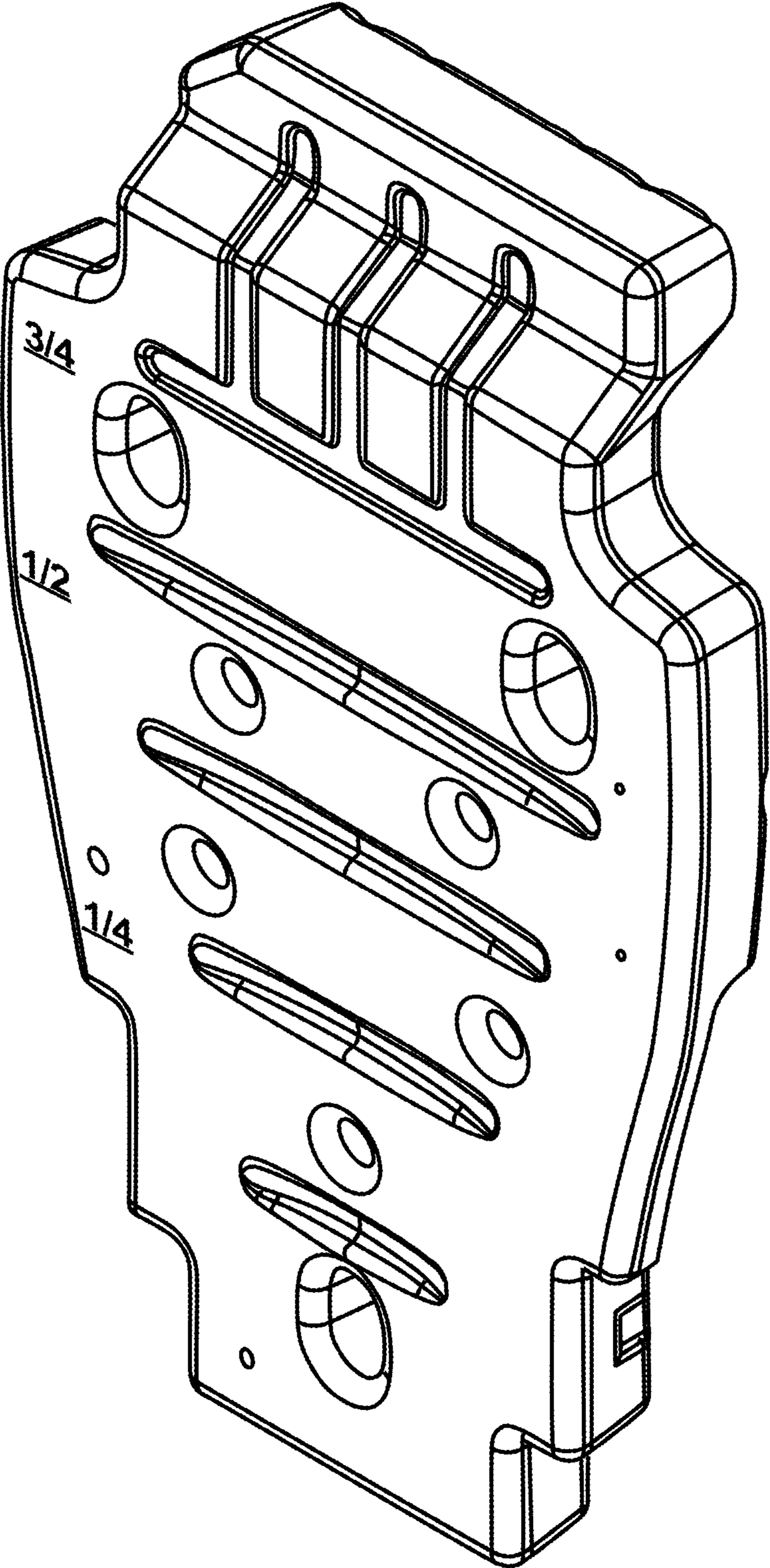

FIG. 1.1

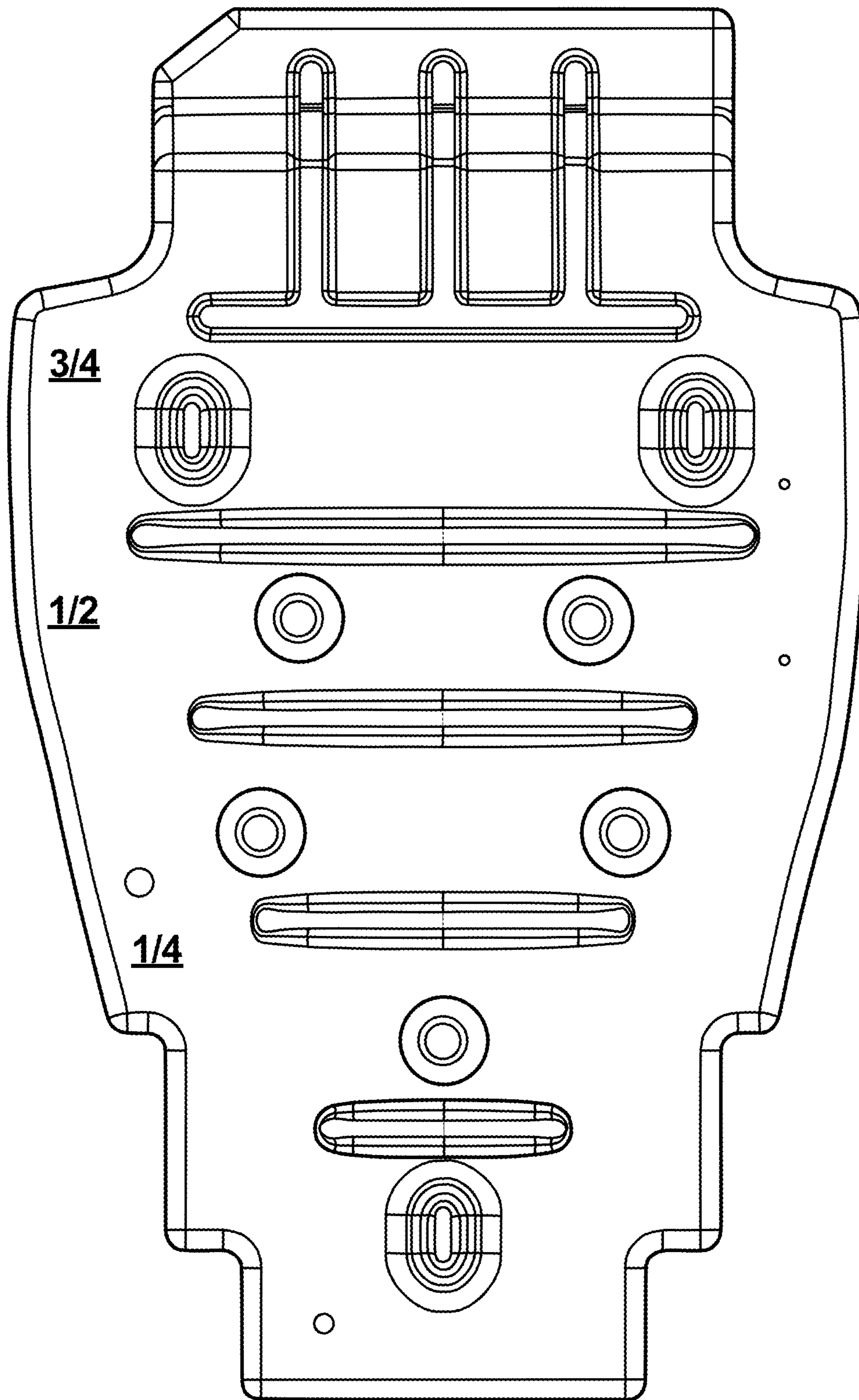
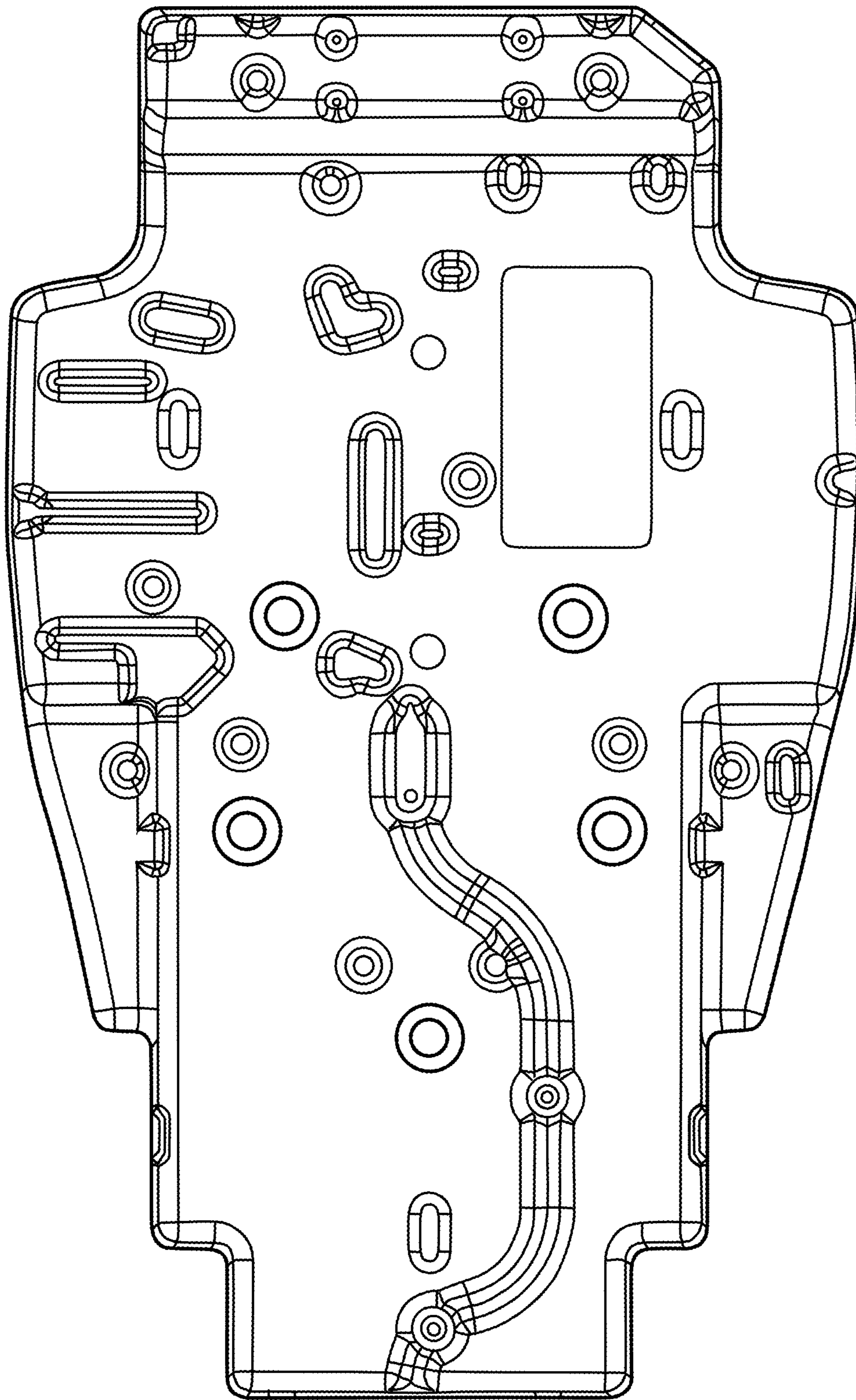

FIG. 1.2



**FIG. 1.3**

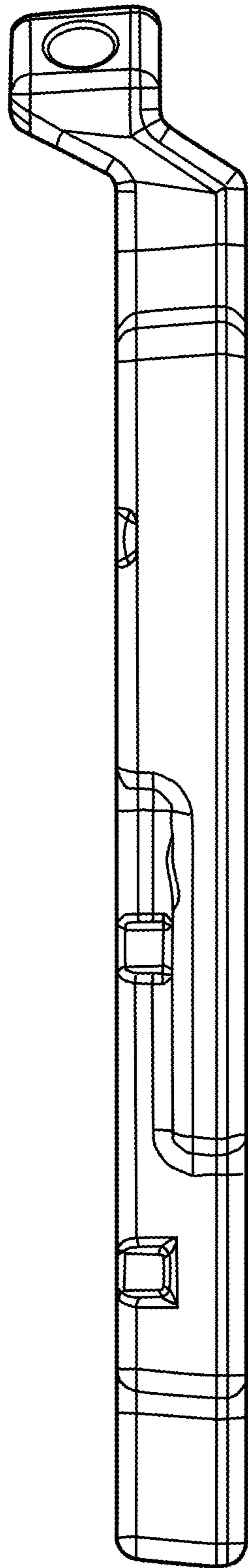
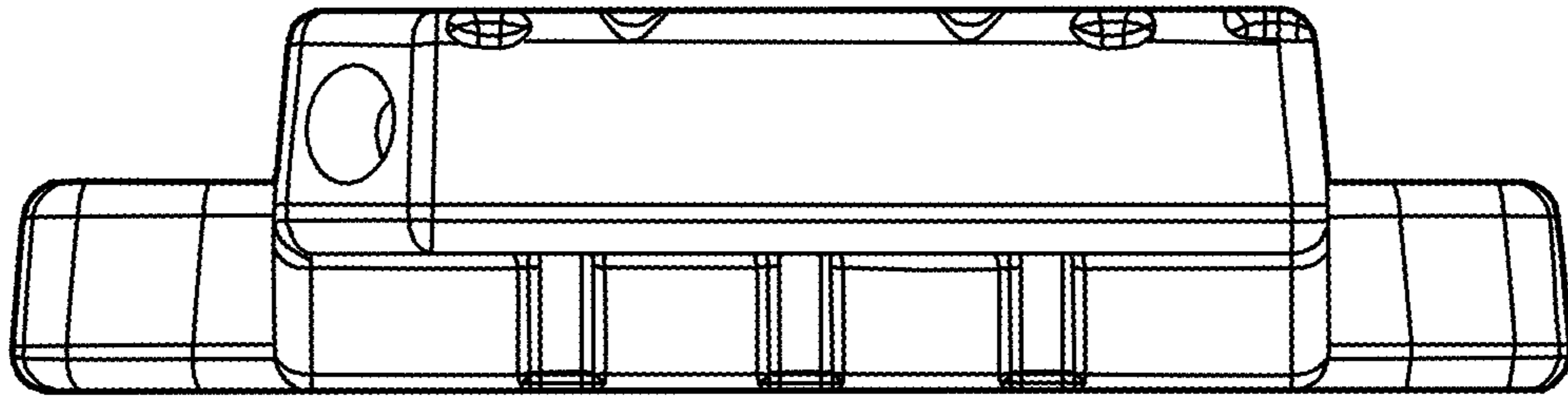
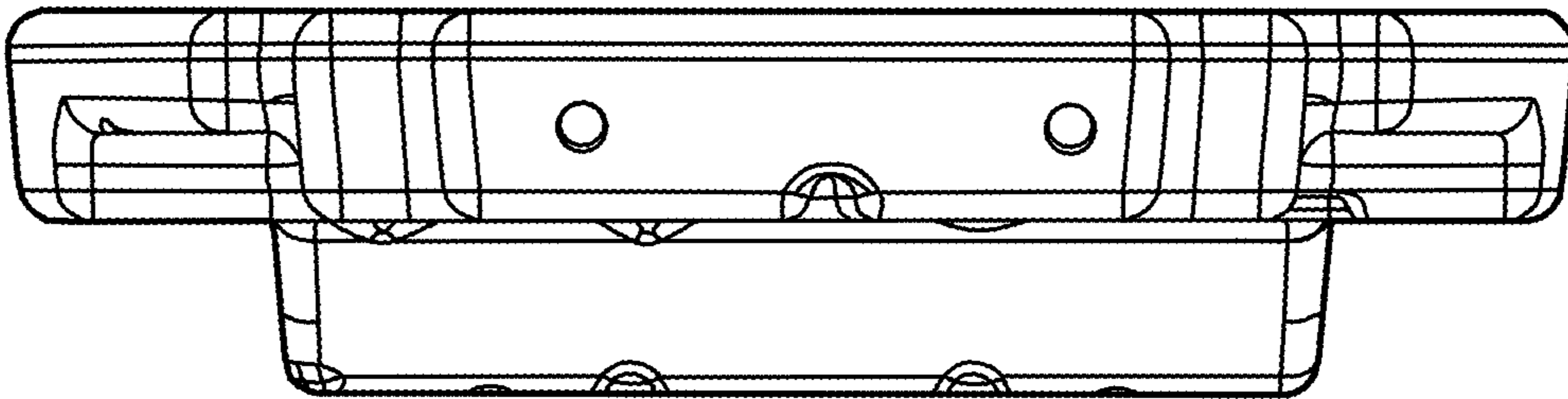

FIG. 1.4



**FIG. 1.5**



**FIG. 1.6**