



US00D968307S

(12) **United States Design Patent**
Matsuda et al.

(10) **Patent No.:** **US D968,307 S**
(45) **Date of Patent:** **** Nov. 1, 2022**

(54) **WHEEL FOR A MOTOR VEHICLE**
(71) Applicant: **MAZDA MOTOR CORPORATION,**
Hiroshima (JP)
(72) Inventors: **Takuya Matsuda,** Hiroshima (JP);
Shinichiro Yamauchi, Hiroshima (JP)
(73) Assignee: **MAZDA MOTOR CORPORATION,**
Hiroshima (JP)

D864,072 S * 10/2019 Groth D12/209
D866,443 S * 11/2019 Peat D12/211
D868,662 S * 12/2019 Moore D12/209
D871,994 S * 1/2020 Bjerke D12/209
D942,359 S * 2/2022 Jónás B60B 3/02
D12/209
D955,962 S * 6/2022 Lesnik D12/211

(**) Term: **15 Years**

(21) Appl. No.: **29/730,963**

(22) Filed: **Apr. 9, 2020**

(51) **LOC (13) Cl.** **12-16**

(52) **U.S. Cl.**
USPC **D12/211**

(58) **Field of Classification Search**
USPC D12/204–213, 501; D21/423, 533, 563,
D21/779

CPC B60B 7/00; B60B 7/01; B60B 7/02; B60B
7/04; B60B 7/06; B60B 3/02; B60B 3/04;
B60B 3/06; B60B 3/10; B60B 1/00;
B60B 1/08; B60B 1/10; B60B 1/12

See application file for complete search history.

(56) **References Cited**

U.S. PATENT DOCUMENTS

D682,179 S 5/2013 Badstuebner
D731,390 S * 6/2015 Kobayashi D12/211
D781,202 S * 3/2017 Mahoney D12/211
D784,894 S * 4/2017 Gardavsky D12/211
D791,050 S * 7/2017 Juergens D12/211
D795,148 S * 8/2017 Ariga D12/209
D799,395 S * 10/2017 Chung D12/209
D811,979 S * 3/2018 Svensson D12/211

OTHER PUBLICATIONS

2023 Mazda CX-50, Published May 15, 2022 [online], [retrieved on
Aug. 9, 2022]. Retrieved from the Internet: https://www.youtube.com/watch?v=rZQ6VW_1knY (Year: 2022).*

* cited by examiner

Primary Examiner — Cary M Robinson

Assistant Examiner — Adam C Mager

(74) *Attorney, Agent, or Firm* — Studebaker & Brackett
PC

(57) **CLAIM**

The ornamental design for a wheel for a motor vehicle, as
shown and described.

DESCRIPTION

FIG. 1 is a first perspective view of a wheel for a motor
vehicle;

FIG. 2 is a second perspective view thereof;

FIG. 3 is a front view thereof;

FIG. 4 is a left side view thereof; the opposite side being a
mirror image of the side shown herein

FIG. 5 is a top view thereof; and,

FIG. 6 is a bottom view thereof.

1 Claim, 3 Drawing Sheets

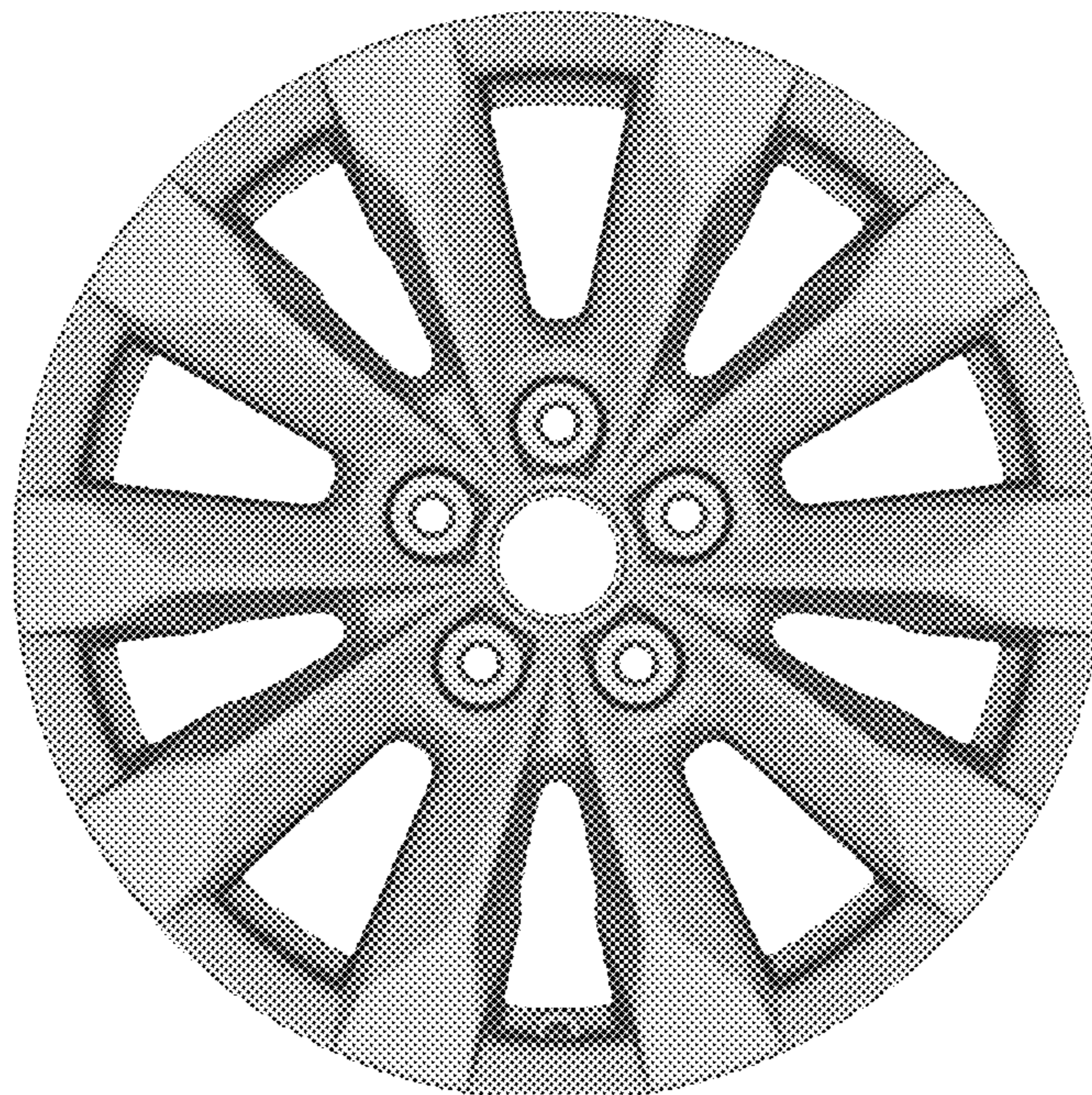



FIG. 1

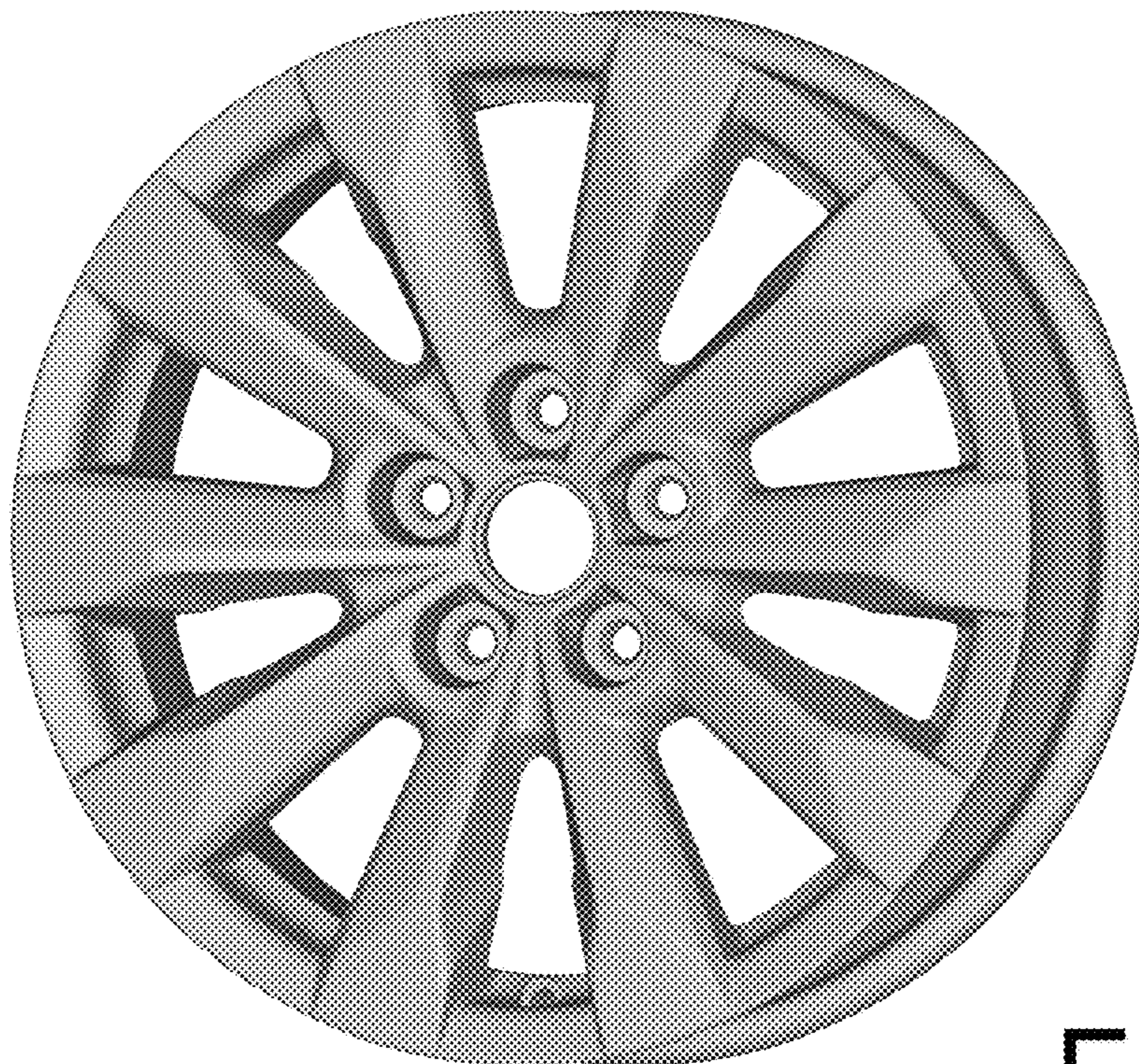

FIG. 2

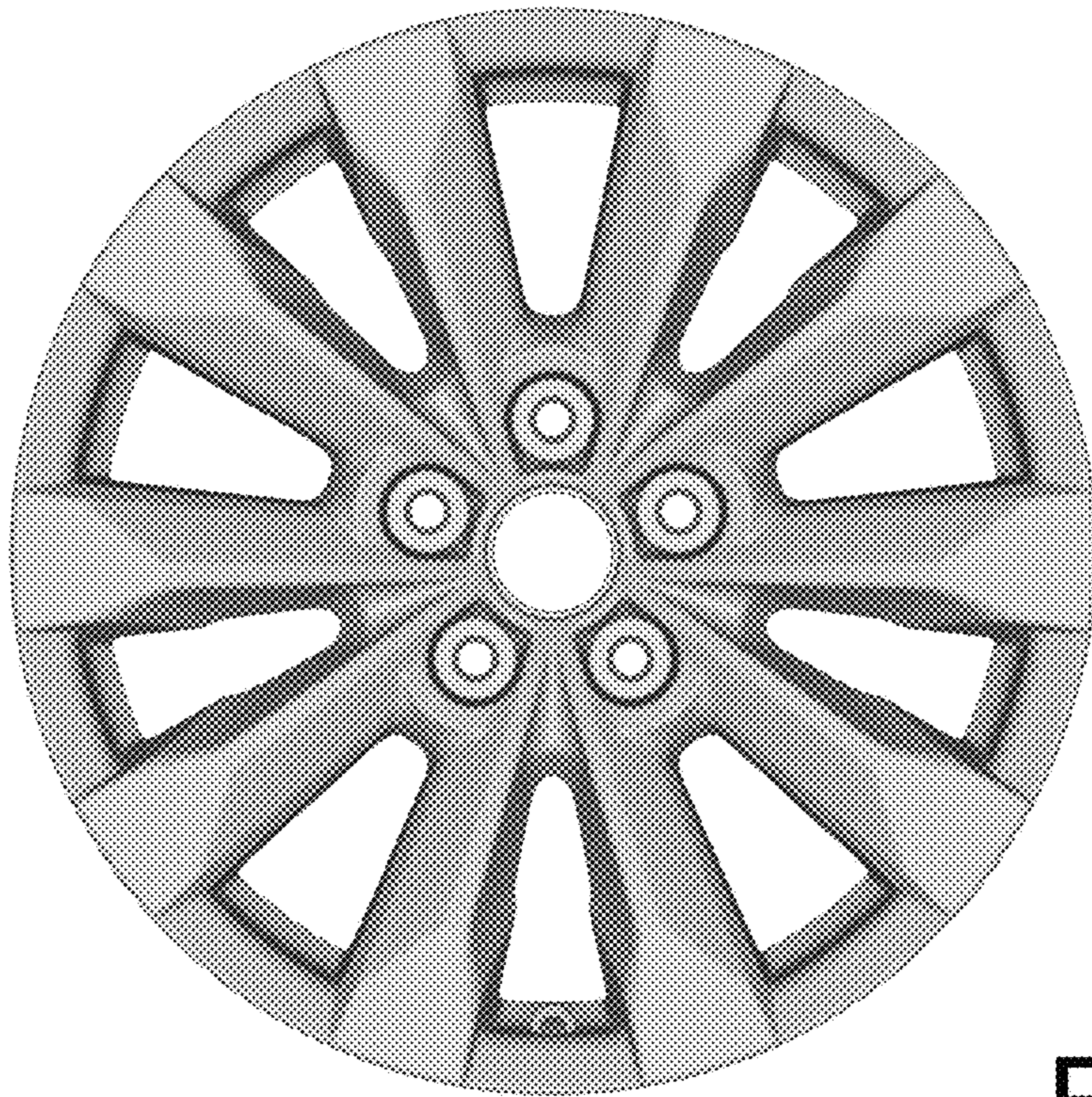

FIG. 3

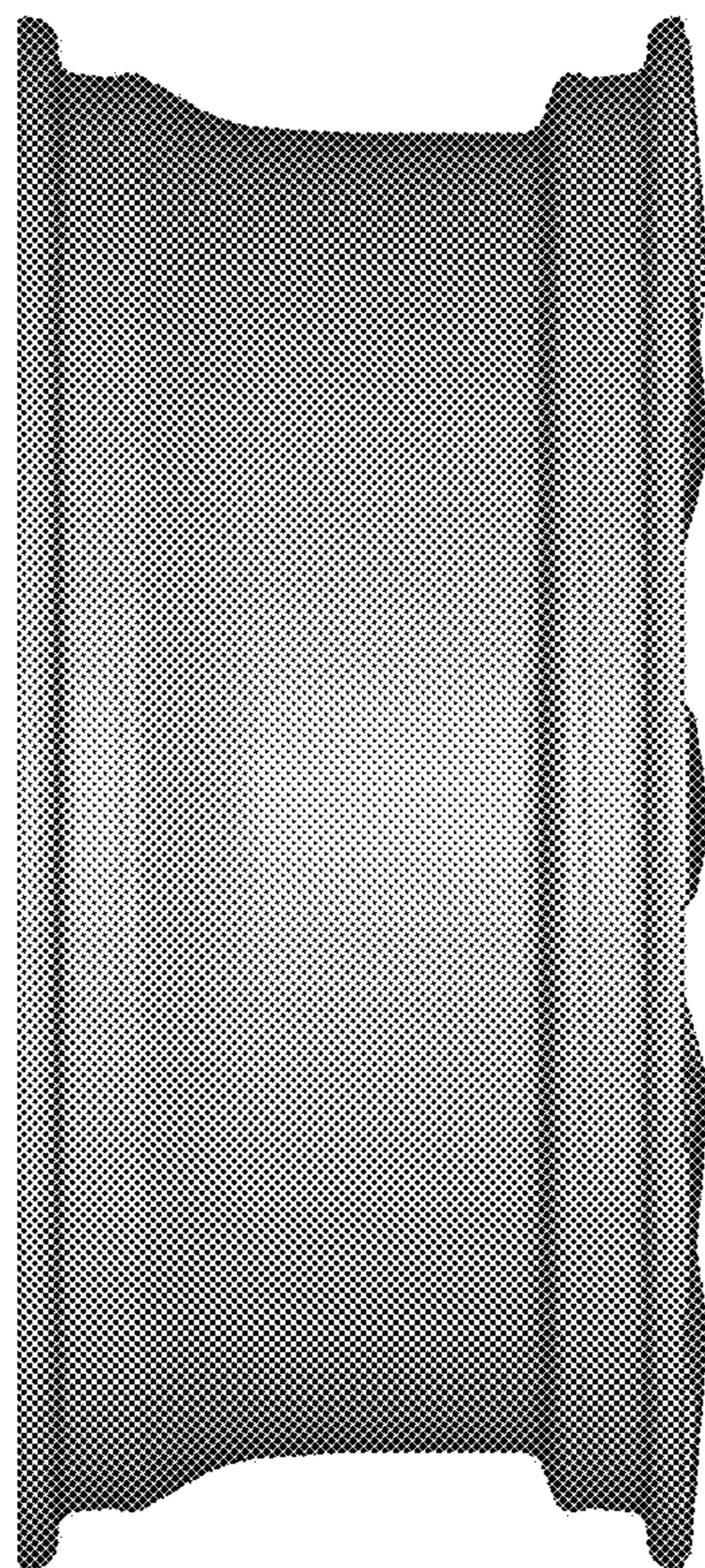

FIG. 4

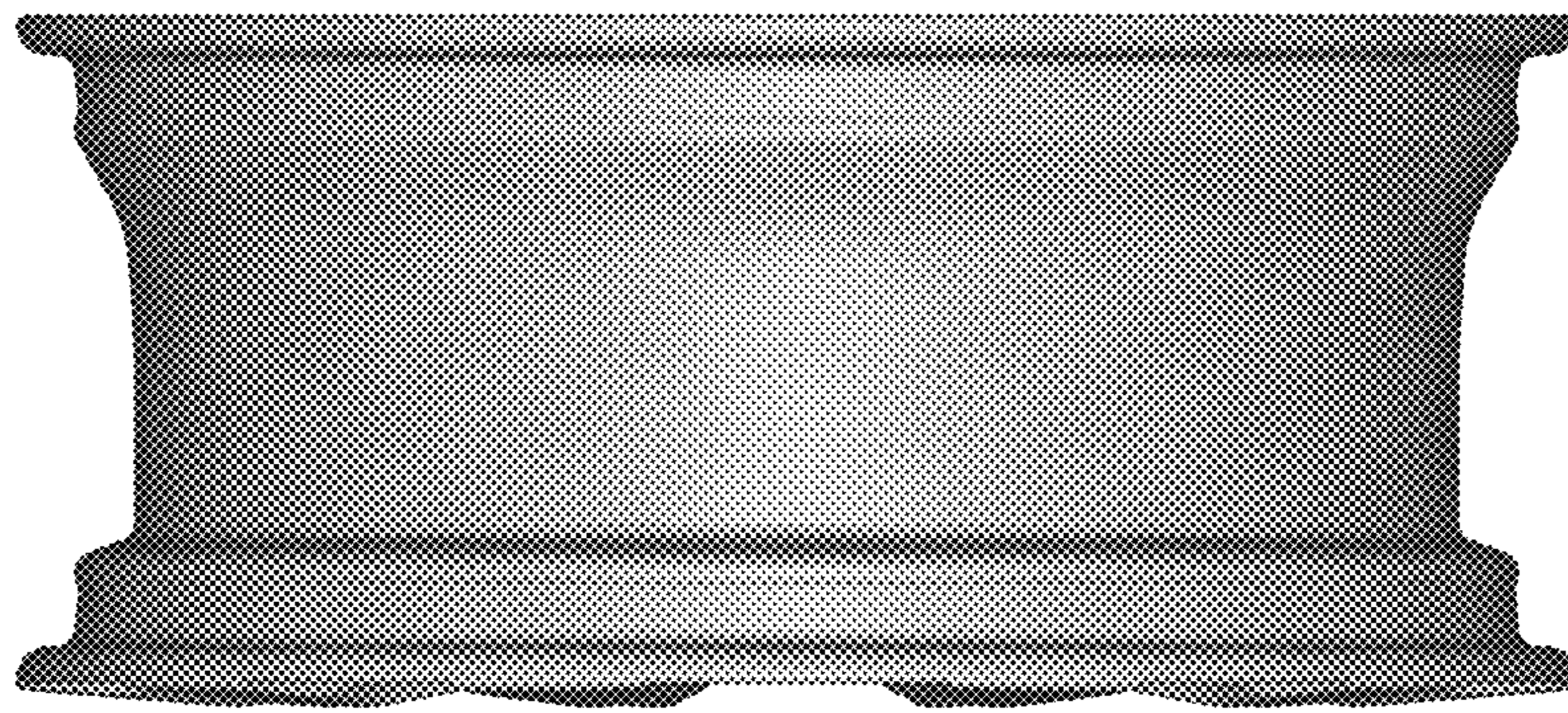

FIG. 5

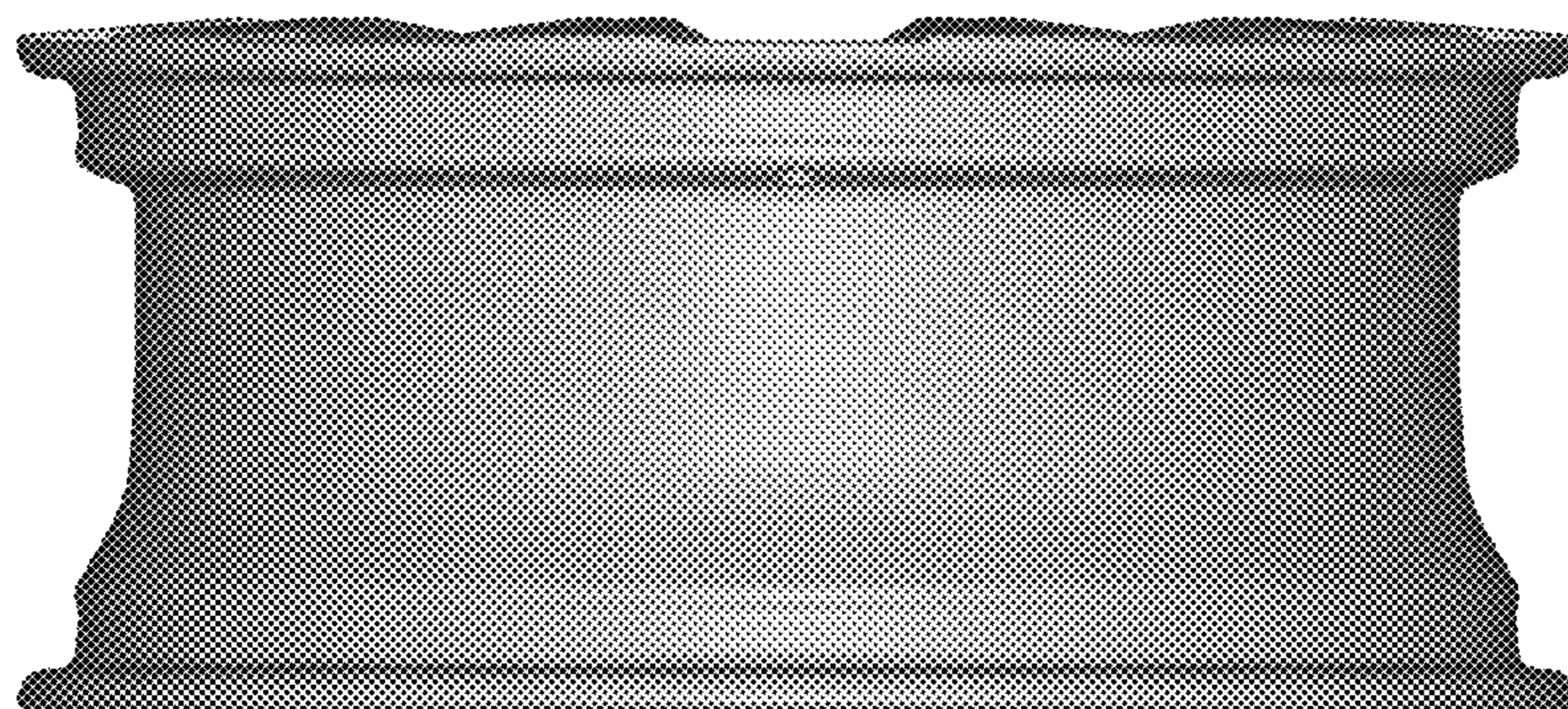

FIG. 6