



US00D968057S

(12) **United States Design Patent**
Gavrieli et al.

(10) **Patent No.:** **US D968,057 S**

(45) **Date of Patent:** **** Nov. 1, 2022**

(54) **DUAL-SOLE SHOE WITH YELLOW STRIPE AND OUTSOLE PATCH**

(71) Applicant: **Gavrieli Brands LLC**, Beverly Hills, CA (US)

(72) Inventors: **Kfir Gavrieli**, Beverly Hills, CA (US);
Dikla Gavrieli, Beverly Hills, CA (US)

(73) Assignee: **Gavrieli Brands LLC**, Beverly Hills, CA (US)

(**) Term: **15 Years**

(21) Appl. No.: **29/758,505**

(22) Filed: **Nov. 16, 2020**

Related U.S. Application Data

(63) Continuation of application No. 17/001,360, filed on Aug. 24, 2020, which is a continuation of application (Continued)

(51) **LOC (13) Cl.** **02-04**

(52) **U.S. Cl.**

USPC **D2/939**; D2/950; D2/971

(58) **Field of Classification Search**

USPC D2/902, 946-962, 896, 900, 904, D2/906-908, 916-924, 925-945, 969, D2/970-979

(Continued)

(56) **References Cited**

U.S. PATENT DOCUMENTS

249,086 A 11/1881 Pienovi
773,850 A 11/1904 Cooper et al.

(Continued)

FOREIGN PATENT DOCUMENTS

DE 20 2006 000230 U1 5/2007
GB 2443937 A 5/2008

(Continued)

OTHER PUBLICATIONS

Examination Report for AU 341324, 3 pgs., dated Oct. 24, 2012.
(Continued)

Primary Examiner — Jonathan J Han

(74) *Attorney, Agent, or Firm* — Morgan, Lewis & Bockius LLP

(57) **CLAIM**

The ornamental design for a dual-sole shoe with yellow stripe and outsole patch, as shown and described.

DESCRIPTION

FIG. 1 is a perspective view of our new design of a dual-sole shoe with yellow stripe and outsole patch, in which the outsole patch is hatched using the USPTO convention of vertical and horizontal cross-hatched lined for yellow or gold (e.g., Pantone 100-Pantone 147, Pantone 155, Pantone 379 or Pantone 380, any one of Pantone 386-Pantone 388, any one of Pantone 393-Pantone 399, any one of Pantone 454-Pantone 461, any one of Pantone 585-Pantone 620, Pantone 803, Pantone 809 or Pantone 810, any one of Pantone 3935-Pantone 3985, or any one of RAL 1000-RAL 1037);

FIG. 2 is a first side view of the design of FIG. 1;

FIG. 3 is a second side view of the design of FIG. 1;

FIG. 4 is a top view of the design of FIG. 1;

FIG. 5 is a bottom view of the design of FIG. 1;

FIG. 6 is a front view of the design of FIGS. 1; and,

FIG. 7 is a back view of the design of Figure.

The broken lines illustrating the half moon patch and the groove in the above described Figures are for illustrative purposes only and form no part of the claimed design.

1 Claim, 6 Drawing Sheets

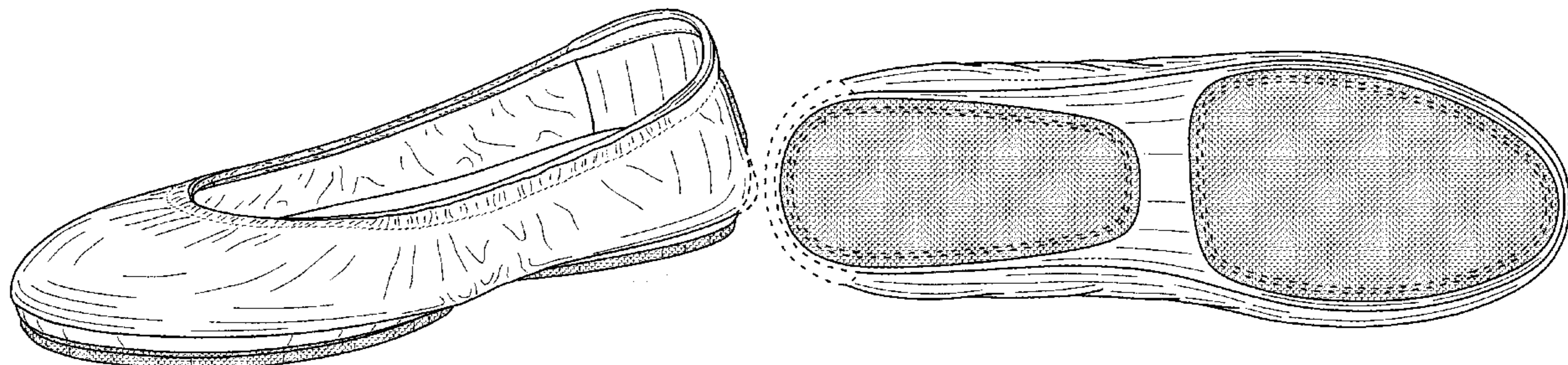

Related U.S. Application Data

No. 15/905,239, filed on Feb. 26, 2018, now abandoned, which is a continuation of application No. 15/204,763, filed on Jul. 7, 2016, now Pat. No. 9,930,925, which is a continuation of application No. 14/266,599, filed on Apr. 30, 2014, now Pat. No. 9,398,786, which is a continuation of application No. 13/207,397, filed on Aug. 10, 2011, now Pat. No. 8,745,893.

(58) **Field of Classification Search**

CPC A43B 13/00; A43B 13/02; A43B 13/023; A43B 13/026; A43B 13/04; A43B 13/08; A43B 13/10; A43B 13/12; A43B 13/14; A43B 13/141; A43B 13/143; A43B 13/16; A43B 13/18; A43B 13/181; A43B 13/187; A43B 13/189; A43B 13/20; A43B 13/22; A43B 13/223; A43B 13/24; A43B 13/28; A43B 13/30; A43B 13/32; A43B 13/34; A43B 13/36; A43B 1/00; A43B 1/02; A43B 1/04; A43B 3/00; A43B 3/02; A43B 3/06; A43B 3/10; A43B 3/12; A43B 3/14; A43B 5/00; A43B 5/001; A43B 5/002; A43B 5/008; A43B 5/06; A43B 5/10; A43B 5/12; A43B 23/00; A43B 23/02; A43B 23/04; A43B 23/14; A43B 23/16; A43B 23/17; A43B 23/24; A43B 23/25; A43B 23/26

See application file for complete search history.

(56) **References Cited**

U.S. PATENT DOCUMENTS

830,941	A	9/1906	Walden
1,208,209	A	12/1916	Prince
1,214,666	A	2/1917	Ford
1,519,009	A	12/1924	Reina
1,525,848	A	2/1925	Bonaventure
1,587,377	A	6/1926	Grosjean
1,650,466	A	11/1927	Righter
2,224,590	A	12/1940	Boivin
2,268,777	A	1/1942	Scholl
D133,819	S	9/1942	Harris
D135,791	S	6/1943	Beebe
2,323,563	A	7/1943	Nugent
2,342,882	A	2/1944	Meltzer
D141,871	S	7/1945	Braun
2,383,585	A	8/1945	Bindner
D149,685	S	5/1948	Sandler
D150,729	S	8/1948	Sandler
D166,090	S	3/1952	Maling
2,772,488	A	12/1956	Meltzer
2,904,814	A	9/1959	Scholl
3,148,378	A	9/1964	Tibbitts
D200,897	S	4/1965	Mitchell
D220,464	S	4/1971	Hayoshi
D247,396	S	3/1978	Schlerth
4,412,393	A	11/1983	Terlizzi, Jr. et al.
D275,525	S	9/1984	Nakao
4,674,206	A	6/1987	Lyden
D295,692	S	5/1988	Zuidema et al.
D300,085	S	3/1989	Ito et al.
RE33,018	E	8/1989	Ostrander
4,899,412	A	2/1990	Ganon
D316,773	S	5/1991	Valle
5,012,541	A	5/1991	Ganon
D339,669	S	9/1993	Miller
5,282,326	A	2/1994	Schroer, Jr. et al.
5,421,050	A	6/1995	Laganas
5,699,629	A	12/1997	Munschy
5,746,014	A	5/1998	Tanemoto
D420,785	S	2/2000	Perez

6,055,745	A	5/2000	Endoh
6,076,284	A	6/2000	Terlizzi
6,189,239	B1	2/2001	Gasparovic et al.
6,338,207	B1	1/2002	Chang
D457,292	S	5/2002	Sessa
D461,947	S	8/2002	Merceron
6,588,124	B2	6/2003	Morrone
D476,798	S	7/2003	Reynolds et al.
D498,041	S	11/2004	McClaskie
D500,191	S	12/2004	Belley et al.
D501,706	S	2/2005	McClaskie
6,857,203	B2	2/2005	Minden
6,895,693	B2	5/2005	Baruck
6,978,557	B2	12/2005	Lee
7,032,327	B1	4/2006	Tartaglia et al.
7,036,244	B1	5/2006	Finch
D527,513	S	9/2006	Della Valle
D529,513	S	10/2006	Aketa
D531,790	S	11/2006	Wurzburg
D534,341	S	1/2007	Choi
D542,513	S	5/2007	Amado et al.
D556,990	S	12/2007	Cabados
7,337,558	B2	3/2008	Terlizzi et al.
D567,485	S	4/2008	James
D570,488	S	6/2008	Kirksey et al.
D571,084	S	6/2008	Comeau
D571,548	S	6/2008	Seamans
D571,989	S	7/2008	Siegal
D580,640	S	11/2008	Wurzburg
D582,638	S	12/2008	Ringholz
7,496,982	B2	3/2009	Clark et al.
7,506,459	B2	3/2009	Grisoni et al.
D591,031	S	4/2009	Cofinco
D593,295	S	6/2009	Belley et al.
D593,297	S	6/2009	Belley et al.
D593,307	S	6/2009	Belley et al.
D599,093	S	9/2009	Issler
D604,030	S	11/2009	Wilson
D607,194	S	1/2010	Zagula
D610,332	S	2/2010	Raichle
D610,785	S	3/2010	Smith
D612,140	S	3/2010	Moon
D612,141	S	3/2010	Moon
7,694,435	B1	4/2010	Kiser et al.
D615,737	S	5/2010	Feller
7,735,244	B1	6/2010	Ameche
7,743,530	B2	6/2010	Truelsen
D618,891	S	7/2010	McClaskie
7,757,408	B2	7/2010	McClaskie
D630,829	S	1/2011	Weisner
D632,881	S	2/2011	Rosenberg
7,926,203	B2	4/2011	Wilkenfeld
7,966,747	B2	6/2011	Wilkenfeld et al.
D640,861	S	7/2011	Wilkenfeld
8,020,320	B2	9/2011	Gillespie
8,127,468	B2	3/2012	Morgan
D657,543	S	4/2012	Bove
D659,960	S	5/2012	Bizzo
8,230,619	B2	7/2012	Salvatelli
D664,755	S	8/2012	Gavrieli et al.
D665,157	S	8/2012	Wu
8,240,067	B2	8/2012	Sussmann
8,245,420	B2	8/2012	Wilson
D668,027	S	10/2012	Millieret
D668,438	S	10/2012	Millieret
D668,847	S	10/2012	Gavrieli et al.
D668,848	S	10/2012	Gavrieli et al.
D668,849	S	10/2012	Pozzi
D668,850	S	10/2012	Pozzi
D672,542	S	12/2012	Gray et al.
D676,634	S	2/2013	Gavrieli et al.
D681,927	S	5/2013	Gavrieli
D681,928	S	5/2013	Gavrieli
D681,929	S	5/2013	Gavrieli
D683,936	S	6/2013	Gavrieli
8,468,723	B2	6/2013	Malka-Harari
D686,812	S	7/2013	Gavrieli et al.
8,510,975	B2	8/2013	Krikelis
D688,853	S	9/2013	Gavrieli

(56)

References Cited

U.S. PATENT DOCUMENTS

D688,854 S 9/2013 Gavrieli
 D688,855 S 9/2013 Gavrieli
 D689,270 S 9/2013 Gavrieli
 D689,271 S 9/2013 Gavrieli
 D689,272 S 9/2013 Gavrieli
 D690,914 S 10/2013 Gavrieli
 D690,915 S 10/2013 Gavrieli
 D696,500 S 12/2013 Hunt
 D699,424 S 2/2014 Hamm
 8,661,714 B2 3/2014 Sussmann
 8,745,893 B2 6/2014 Gavrieli et al.
 8,973,287 B2 3/2015 Shibata
 9,167,862 B2 * 10/2015 Gavrieli A43B 3/248
 D761,538 S * 7/2016 Gavrieli D2/939
 9,398,786 B2 7/2016 Gavrieli
 9,565,908 B2 * 2/2017 Gavrieli A45C 3/00
 D781,032 S * 3/2017 Gavrieli A43B 23/0245
 D781,033 S * 3/2017 Gavrieli A43B 3/24
 D781,035 S * 3/2017 Gavrieli A43B 23/0245
 D782,167 S 3/2017 Gavrieli
 9,930,925 B2 * 4/2018 Gavrieli A43B 5/12
 D819,940 S * 6/2018 Gavrieli D2/939
 D824,150 S * 7/2018 Gavrieli D2/939
 D831,312 S 10/2018 Gavrieli
 D837,495 S * 1/2019 Gavrieli D2/939
 D844,950 S * 4/2019 Gavrieli A43B 3/108
 D844,951 S * 4/2019 Gavrieli A43B 13/14
 D846,246 S * 4/2019 Gavrieli A43B 13/14
 D846,259 S * 4/2019 Gavrieli A43B 3/10
 D846,845 S * 4/2019 Gavrieli A43B 13/141
 D846,847 S * 4/2019 Gavrieli D2/939
 D846,848 S * 4/2019 Gavrieli D2/939
 D846,849 S * 4/2019 Gavrieli A43B 3/108
 10,258,121 B2 * 4/2019 Gavrieli A45C 3/12
 D851,872 S * 6/2019 Gavrieli D2/939
 D853,091 S * 7/2019 Gavrieli D2/971
 D853,697 S * 7/2019 Gavrieli D2/939
 D853,698 S * 7/2019 Gavrieli D2/939
 D884,323 S * 5/2020 Gavrieli D2/947
 D885,018 S * 5/2020 Gavrieli D2/939
 D886,435 S * 6/2020 Gavrieli A43B 3/108
 D888,380 S * 6/2020 Gavrieli A43B 5/12
 D891,047 S * 7/2020 Gavrieli D2/939
 D901,859 S * 11/2020 Gavrieli A43B 13/122
 D901,860 S * 11/2020 Gavrieli D2/950
 D901,862 S * 11/2020 Gavrieli D2/971
 D903,279 S * 12/2020 Gavrieli A43B 5/12
 2002/0078591 A1 6/2002 Morrone
 2002/0129519 A1 9/2002 Cahan
 2003/0070319 A1 4/2003 Minden
 2003/0121176 A1 7/2003 Baruck
 2004/0025377 A1 2/2004 Brannon
 2005/0022421 A1 2/2005 Bruckner
 2005/0115115 A1 6/2005 Lacey
 2005/0217148 A1 10/2005 Connolly et al.
 2005/0262734 A1 12/2005 Cheng
 2006/0086005 A1 4/2006 Yerian
 2006/0156576 A1 7/2006 Sloan
 2007/0074424 A1 4/2007 Lin
 2007/0204482 A1 9/2007 Gibson-Collinson
 2007/0204483 A1 9/2007 Kirsch et al.

2008/0052964 A1 3/2008 Taylor
 2008/0086912 A1 4/2008 Wilkenfeld
 2008/0110059 A1 5/2008 Kuramoto et al.
 2009/0019732 A1 1/2009 Sussmann
 2009/0193685 A1 8/2009 Wilson
 2009/0205222 A1 8/2009 Mclinden
 2009/0272009 A1 11/2009 Weisner et al.
 2010/0011625 A1 1/2010 Percival
 2010/0018080 A1 1/2010 Smith
 2010/0050469 A1 3/2010 Chen
 2010/0095557 A1 4/2010 Jarvis
 2010/0115793 A1 5/2010 Kraisosky
 2010/0122475 A1 5/2010 Purrington
 2010/0146822 A1 6/2010 MacGregor
 2010/0212186 A1 8/2010 Cheng
 2010/0275462 A1 11/2010 Pucci
 2010/0281713 A1 11/2010 Pantazes
 2013/0036630 A1 * 2/2013 Gavrieli A43B 3/108
 2013/0039605 A1 * 2/2013 Gavrieli A45C 3/12
 2015/0089843 A1 4/2015 Gavrieli
 2016/0029755 A1 * 2/2016 Gavrieli A45C 3/12
 2017/0295897 A1 * 10/2017 Gavrieli A45C 13/1046
 2019/0223567 A1 * 7/2019 Gavrieli A45C 13/1046

FOREIGN PATENT DOCUMENTS

GB 2 446 205 A 8/2008
 TW D119165 10/2007

OTHER PUBLICATIONS

Letter from TMI and Associates with Office Action, 2 pgs, dated Sep. 19, 2012 <http://www.payless.com/store/?&TLC=Womens&SLC=WomensNewArrivals&BLC=WomensNewArrivals&With+Regular&ItemCode=60131&LotNumber=062642&Type=Adult&Popularity=637&Descriptvein>.
 Taiwanese Office Action for TW 101300726, 10 pgs., dated Sep. 6, 2012.
 “The Love List, Tiefs by Gavrieli—Foldable Ballet Flats,” <http://thelovelist-carlyblogspot.com.au/2010/09/tiefs-by-gavrieli-foldable-ballet.html>, 2 pgs., Sep. 12, 2010.
 “Tiefs by Gavrieli,” <http://tiefs.com>, 1 pg., retrieved Mar. 13, 2013 from URL.
 “Try It Mummy!, Tiefs by Gavrieli,” <http://tryitmummy.blogspot.com.au/2010/12/tiefs-by-gavrieli.html>, 3 pgs., Dec. 9, 2010.
 “Wearability—Real People Style, What came first, the City Flat or the Tiefs,” <http://wearability.posterous.com/what-came-first-the-city-flat-or-the-tiefs>, 2 pgs., Aug. 29, 2010.
 “The Ballet Flat . . . Reinvented; Ballet Flats . . . with a Bonus; Step Into Tiefs; Going Places? Take Tiefs,” <http://web.archive.org/web/2010052004346/http://www.tiefs.com/>; 4 pgs., May 24, 2010.
 “Tiefs—Comfortable designer flats you can fit in your purse and wear all day, every day,” <http://web.archive.org/web/20110731151555/http://tiefs.com/>; 6 pgs., Jul. 31, 2011.
 “58th Annual Emmy Awards,” http://spoonsforksandfashion.blogspot.com/2006_08_01_archive.html, depicting Nine West flats, 2 pgs., Aug. 1, 2006.
 Pictures of Nine West flats sold in 2006, 3 pgs.
 “I Love a Good Ballet Flat!,” <http://dressupfiles.com/i-love-a-good-ballet-flat>, depicting Sue London flats, 3 pgs., Sep. 3, 2010.
 Pictures of Sue London flats sold in 2010, 2 pgs.
 “Miss Cathie Reviews: The Yosi Samra Foldable Ballet Flat . . .,” <http://www.misscathie.com/2010/01/miss-cathie-reviews-the-yosi-samra-foldable-ballet-flat/>, depicting Yosi Samra flats, 9 pgs., Jan. 2010.
 Pictures of Yosi Samra flats sold in 2010, 2 pgs.
 “Goodbye two thousand ten,” http://emmajoyrussell.blogspot.com/2010_12_01_archive.html, depicting Gap flats, 39 pgs., Dec. 1, 2010.
 Pictures of Gap flats available for sale in 2010, 9 pgs.

(56)

References Cited

OTHER PUBLICATIONS

“Our newest design of folding flats-Pink,” <https://fitinclouds.wordpress.com/2010/05/16/our-newest-design-of-folding-flats-pink/>, depicting Fit in Clouds flats, 1 pg., May 16, 2010.

“Fit in Clouds Satin Folding Shoes,” <http://www.goodhousekeeping.com/product-reviews/clothing/best-ballet-flats/fit-in-clouds-satin-foldable-ballet-flats>, depicting Fit in Clouds flats, 2 pg., Aug. 2013. Pictures of Fit in Clouds flats available for sale in 2011, 4 pgs.

“Shoes for Standing,” <https://truthinshoes.wordpress.com/2008/07/>, depicting Sam & Libby flats, 2 pgs., Jul. 31, 2008.

“Target Designer Collaboration: Announcing Sam & Libby Shoes for Target,” <http://www.therecessionista.com/2012/11/target-designer-collaboration-announcing-sam-libby-shoes-for-target.html>, depicting Sam & Libby flats, 1 pg., Nov. 26, 2012.

Pictures of Sam & Libby flats available for purchase in 2011, 5 pgs.

“Save your soles with Citisoles ballet flats,” <http://glamazondiaries.com/2009/07/save-your-soles-with-citisoles-ballet-flats>, depicting Citisoles flats, 3 pgs., Jul. 2009.

Pictures of Citisoles flats available for purchase in 2009, 3 pgs.

“#16 Corso Como Delicious Pumps Review and Giveaway!,” <http://www.mommatoldmeblog.com/2011/01/16-corso-como-delicious-pumps-review.html>, depicting Corso Como flats, 8 pgs., Jan. 16, 2011.

Pictures of Corso Como flats available for sale in 2011, 3 pgs.

“Jil-sander-navy-lead-ballet-flats-product . . . ,” www.ebay.com, depicting Jil Sander flats, 4 pgs., Nov. 2013.

Pictures of Jil Sander flats available for sale in 2011, 3 pgs.

“Spare Soles: Shoes That Roll-up & Fold-up,” <http://herpackinglist.com/2011/01/spare-soles-shoes/>, depicting Spare Soles flats, 2 pgs., January 2011.

Pictures of Spare Soles flats available for sale in 2011, 5 pgs.

Pictures of Roll-Upz by Spare Soles flats available for sale in 2011, 6 pgs.

“The Cutest Blog, Preppy 50 and Loving Lilly, Ballet Flat Delight,” <http://preppys50andlovinglilly.blogspot.com/2011/02/ballet-flat-delight.html>, depicting Henri Bendel flats, 1 pg., Feb. 19, 2011.

Pictures of Henri Bendel flats available for sale in 2011, 4 pgs.

“Mumsnet by parents for parents,” http://www.mumsnet.com/Talk/style_and_beauty/a1612000-Anyone-tried-Redfoot-Flatmates-foldable-ballet-pumps, depicting Redfoot Flatmates flats, 1 pg, Nov. 14, 2012.

Pictures of Redfoot Flatmates flats available for sale in 2011, 6 pgs.

“Amazon.com: Customer Reviews: Bloch London Women’s Lux Ballet Flat,” <http://www.amazon.com/Bloch-London-Womens-Ballet-Flat/product-reviews/B004LWP7YW>, depicting Bloch London flats, 4 pgs., Dec. 11, 2011.

Pictures of Bloch London flats offered for sale in 2011, 11 pgs.

“H&m foldable leopard print flat,” <https://8485shops.wordpress.com/2011/06/16/flats-for-7-bucks/shoe1/>, depicting h&m flats, 2 pgs., Jun. 16, 2011.

Pictures of h&m foldable flats offered for sale in 2011, 4 pgs.

“Seekyt—Juicy Couture Ballet Flats—Are They Worth The Money?,” <http://seekyt.com/juicy-couture-ballet-flats-are-they-worth-the-money/>, 2 pgs., Jun. 3, 2011.

Pictures of Juicy Couture flats offered for sale in 2011, 3 pgs.

“Purse Flats,” <http://purseflats.wordpress.com>, depicting Purse Flats by Erica Wilson, 3 pgs., Jul. 12, 2012.

Pictures of Purse Flats by Erica Wilson offered for sale in 2011, 6 pgs.

“Tieks by Gavrieli—Comfortable, designer flats you can fit in your purse and wear all day . . . ,” <http://web.archive.org/web/20110202210649/http://www.tieks.com/>, 8 pgs., Feb. 2, 2011.

“Carolina M. M. Gonzalez > Tieks by Gavrieli,” http://m2.facebook.com/Tieks?v=timeline&filter=2&timecutoff=1406427986&page=17§ionLoadingID=m_timeline_loading_div_1293868799_1262332800_8_17&timeend=1293868799×tart=1262332800&tm=AQDOvghWQPN_Nbwm&refid=17, 1 pg. Jan. 26, 2010.

“The Shoes Oprah Would Wear to Work (if She Had to Walk),” <http://www.inc.com/30under30/christina-desmarais/kfir-gavrieli-and-elram-gavrieli-founders-of-tieks.html>, 2 pgs., Jul. 2, 2012.

“Tieks by Gavrieli,” http://m2.facebook.com/Tieks?v=timeline&filter=2&timecutoff=1406427986&page=14§ionLoadingID=m_timeline_loading_div_1293868799_1262332800_8_14&timeend=1293868799×tart=1262332800&tm=AQDOvghWQPN_Nbwm&refid=17, 4 pgs., Jan. 26, 2010.

“Mighty Life List, Sensible Shoes,” <http://mightygirl.com/2010/08/24/sensible-shoes/>, 11 pgs., Aug. 24, 2010.

“Find! Tieks: Fab & sexy flats for fall,” <http://thefabmom.com/2013/08/29/find-tieks-fab-sexy-flats-for-fall/>, 3 pgs. Aug. 29, 2013.

“Step into Tieks,” <http://sliceofpink.typepad.com/bloq/2010/09/tieks-1.html>, 5 pgs., Sep. 22, 2010.

“In Need of Flat-Soled Shoes,” <http://www.kellywickham.com/mochamomma/2010/10/4/in-need-of-flat-soled-shoes.html>, 4 pgs., Oct. 3, 2010.

“Say Hello to the Flat Shoes You Need for Fall . . . All 88 of Them!”, Picture of Adam Tucker Shoe/Slipper, <https://www.facebook.com/search/top/?g=adam%20shoes%20slipper>, last accessed Oct. 28, 2016, dated Oct. 1, 2013, 1 page.

Picture of Adam Tucker Rainbow Shoes, <https://www.facebook.com/search/top/?g=adam%20shoes%20rainbow>, last accessed Oct. 28, 2016, dated Aug. 14, 2013, 1 page.

Third Party Submission Under 37 CFR 1.290 regarding U.S. Appl. No. 15/905,239, filed Feb. 9, 2019, 94 pages.

Order Granting TRO (D.I. 11), *Gavrieli Brands LLC vs. Soto Massini*, Civil Action No. 1:18-cv-00462, Mar. 28, 2018, 2 pages.

Defendants’ Opposition To Motion For Temporary Restraining Order, Civil Action No. 1:18-cv-00462-GMS, Apr. 1, 2018, 12 pages.

Declaration of Thomas Pichler In Opposition To Tro Request, C.A. No. 1:18-cv-00462-GMS, Apr. 1, 2018, 8 pages.

Exhibit A to Pichler Declaration ISO TRO Opposition (D.I. 13-1), C.A. No. 1:18-cv-00462-GMS, Apr. 1, 2018, 29 pages.

Order TRO (D.I. 18), C.A. No. 1:18, Apr. 4, 2018, 3 pages.

Defendant Soto Massini (USA) Corporation’s Answer and Counterclaims To Verified Complaint for Patent Infringement, Trade Dress Infringement, and Unfair Competition, C.A. No. 1:18-cv-00462-GMS, May 1, 2018, 26 pages.

Defendant Soto Massini (USA) Corporation’s Answer To Amended Complaint and Amended Counterclaims, C.A. No. 1:18-cv-00462-GMS, Jun. 5, 2018, 28 pages.

Defendant Soto Massini (USA) Corporation’s Answer To Amended Complaint and First Amended Counterclaims, C.A. No. 1:18-cv-00462-GMS, Jul. 12, 2018, 31 pages.

Exhibit A to SACC (45-1), Case 1:18-cv-00462-GMS, 3 pages.

Exhibit B to SACC (45-2), Case 1:18-cv-00462-GMS, 5 pages.

Exhibit C to SACC (45-3), Case 1:18-cv-00462-GMS, 5 pages.

Exhibit D to SACC (45-4), Case 1:18-cv-00462-GMS, 4 pages.

Defendant Soto-USA’s Invalidity Contentions, C.A. No. 1:18-cv-00462-MN, 16 pages.

Redacted Verdict Form (D.I. 144), Case 1:18-cv-00462-GMS, 13 pages.

Judgement (D.I. 149), C.A. No. 18-462-MN, May 13, 2019, 3 pages.

Gavrieli Brands, LLC, v. Soto Massini (USA) Corp., et al., (full) Trial Transcript, C.A. No. 18-462(MN), vol. 1, 733 pages.

Expert Report of Caroline de Baere (Fed. R. Civ. P. 26(a)(2)(B)), Case No. 18-cv-00462-MN, Mar. 1, 2019, 33 pages.

Exhibit 23, Infringement Analysis in Light of the Alleged Prior Art, 41 pages.

Expert Report of Lance Rake, (Fed. R. Civ. P. 26(a)(2)(B)), Mar. 1, 2019, 27 pages.

U.S. Pat. No. 1,525,848, Feb. 10, 1925, B. S. Bonaventure, 3 pages.

U.S. Design Patent No. 247,396, Mar. 7, 1978, William A. Schlerth, 2 pages.

U.S. Design Patent No. D611,693 S, Mar. 16, 2010, Barbara Schwartz, 7 pages.

Camper Book Excerpt—Nina Right, (pp. 334-335), The Walking Society, Lars Müller Publishers, 3 pages.

Camper History—The Shoes, Every Season We Strive To Reinvent Some Of Our Classic Concepts While Continuing To Challenge The Status Quo With New And Original Designs. We Often Find That There Is A Camper Style For Every Walk Of Life, 8 pages.

(56)

References Cited

OTHER PUBLICATIONS

Tieks by Gavrieli—Comfortable, designer flats you can fit in your purse and wear all day, every day!, Copperhead Snake Print Tieks, <https://web.archive.org/web/20101230062534/http://www.tieks.com:80/>, Dec. 30, 2010, 1 page.

Tieks by Gavrieli—Comfortable, designer flats you can fit in your purse and wear all day, every day!, Merlot Lizard Print Tieks, <https://web.archive.org/web/20101230062534/http://www.tieks.com:80/>, Dec. 30, 2010, 1 page.

Tieks by Gavrieli—Comfortable, designer flats you can fit in your purse and wear all day, every day!, Slate Grey Tieks, <https://web.archive.org/web/20101230062534/http://www.tieks.com:80/>, Dec. 30, 2010, 1 page.

Tieks by Gavrieli—Comfortable, designer flats you can fit in your purse and wear all day, every day!, Camel, <https://web.archive.org/web/20101230062534/http://www.tieks.com:80/>, Dec. 30, 2010, 1 page.

Tieks by Gavrieli—Comfortable, designer flats you can fit in your purse and wear all day, every day!, Lilac, <https://web.archive.org/web/20101230062534/http://www.tieks.com:80/>, Dec. 30, 2010, 1 page.

Tieks by Gavrieli—Comfortable, designer flats you can fit in your purse and wear all day, every day!, Leopard Print, <https://web.archive.org/web/20101230062534/http://www.tieks.com:80/>, Dec. 30, 2010, 1 page.

Tieks by Gavrieli—Comfortable, designer flats you can fit in your purse and wear all day, every day!, The Tieks eGift card . . . Always the perfect fit, <https://web.archive.org/web/20101230082534/http://www.tieks.com:80/>, Dec. 30, 2010, 1 page.

Tieks by Gavrieli—Comfortable, designer flats you can fit in your purse and wear all day, every day!, Copperhead Snake Print, <https://web.archive.org/web/20110222174850/http://www.tieks.com:80/>, Feb. 22, 2011, 1 page.

Tieks by Gavrieli—Comfortable, designer flats you can fit in your purse and wear all day, every day!, Patent Tiek Blue, <https://web.archive.org/web/20110222174850/http://www.tieks.com:80/>, Feb. 22, 2011, 1 page.

Tieks by Gavrieli—Comfortable, designer flats you can fit in your purse and wear all day, every day!, Tangerine, <https://web.archive.org/web/20110222174350/http://www.tieks.com:80/>, Feb. 22, 2011, 1 page.

Tieks by Gavrieli—Fashionable Flats That Fit in Your Purse California Navy, <https://web.archive.org/web/20100516173039/http://www.tieks.com:80/california-navy.html>, May 16, 2010, 1 page.

Tieks by Gavrieli—Fashionable Flats That Fit in Your Purse Cardinal Red, <https://web.archive.org/web/20100516173045/http://www.tieks.com:80/cardinal-red.html>, May 16, 2010, 1 page.

Tieks by Gavrieli—Fashionable Flats That Fit in Your Purse Metallic Gold, <https://web.archive.org/web/20100516173106/tieks.com/metallic-gold.html>, May 16, 2010, 1 page.

Tieks by Gavrieli—Fashionable Flats That Fit in Your Purse Patent Tiek Blue, <https://web.archive.org/web/20100516173130/http://www.tieks.com:80/tiek-blue.html>, May 16, 2010, 1 page.

Tieks by Gavrieli—Fashionable Flats That Fit in Your Purse Splash Page, The Ballet Flat . . . Reinvented, <https://web.archive.org/web/20100513055818/https://tieks.com/>, May 13, 2010, 1 page.

Tieks by Gavrieli—Fashionable Flats That Fit in Your Purse Splash Page, Ballet Flats . . . with a Bonus, <https://web.archive.org/web/20100513055818/https://tieks.com/>, May 13, 2010, 1 page.

Tieks by Gavrieli—Fashionable Flats That Fit in Your Purse Splash Page, Going Places? Take Tieks. <https://web.archive.org/web/20100513055818/https://tieks.com/>, May 13, 2010, 1 page.

Tieks by Gavrieli—Fashionable Flats That Fit in Your Purse Splash Page, Step Into Tieks, <https://web.archive.org/web/20100513055818/https://tieks.com/>, May 13, 2010, 1 page.

Tieks by Gavrieli—Fashionable Flats That Fit in Your Purse True Blue, <https://web.archive.org/web/20100516173135/http://www.tieks.com:80/true-blue.html>, May 16, 2010, 1 page.

Tieks by Gavrieli—Fashionable Flats That Fit in Your Purse White Croc Print, <https://web.archive.org/web/20100518173145/http://www.tieks.com:80/white-croc-print.html>, May 16, 2010, 1 page.

Tieks by Gavrieli—Foldable Fashionable Ballet Flats, Wild Copper, Be a little wild . . . even when you're not., <https://web.archive.org/web/20100819185503/https://tieks.com/>, Aug. 19, 2010, 1 page.

Tieks by Gavrieli—Foldable Fashionable Ballet Flats, Paradise Blue, The perfect pair for day and night, <https://web.archive.org/web/20100819165503/https://tieks.com/>, Aug. 19, 2010, 1 page.

Tieks by Gavrieli—Foldable Fashionable Ballet Flats, Obsidian Black, When workdays spill over into party nights., <https://web.archive.org/web/20100819165503/https://tieks.com/>, Aug. 19, 2010, 1 page.

Tieks by Gavrieli—Foldable Fashionable Ballet Flats, Fuchsia, Sweet and sultry, <https://web.archive.org/web/20100819185503/https://tieks.com/>, Aug. 19, 2010, 1 page.

Tieks by Gavrieli—Foldable Fashionable Ballet Flats, Tan Croc print Tieks, A timeless texture., <https://web.archive.org/web/20100819165503/https://tieks.com/>, Aug. 19, 2010, 1 page.

Tieks by Gavrieli—Foldable Fashionable Ballet Flats, Be a little wild . . . even when you're not., <https://web.archive.org/web/20100902020755/https://tieks.com/>, Sep. 2, 2010, 1 page.

Tieks by Gavrieli—Foldable Fashionable Ballet Flats, Obsidian Black, When workdays spill over into party nights, <https://web.archive.org/web/20100902020755/https://tieks.com/>, Sep. 2, 2010, 1 page.

Tieks by Gavrieli—Foldable Fashionable Ballet Flats, Tan Croc Print, A timeless texture, <https://web.archive.org/web/20100902020755/https://tieks.com/> Sep. 2, 2010, 1 page.

Tieks by Gavrieli—Foldable Fashionable Ballet Flats, Paradise Blue, The perfect pair for day and night, <https://web.archive.org/web/20100902020755/https://tieks.com/> Sep. 2, 2010, 1 page.

Tieks by Gavrieli—Foldable Fashionable Ballet Flats, Fuchsia, Sweet and sultry, <https://web.archive.org/web/20100902020755/https://tieks.com/>, Sep. 2, 2010, 1 page.

Tieks by Gavrieli—Foldable Fashionable Ballet Flats, Tiek Blue Tieks, Let yourself shine, <https://web.archive.org/web/20100902020755/https://tieks.com/>, Sep. 2, 2010, 1 page.

* cited by examiner

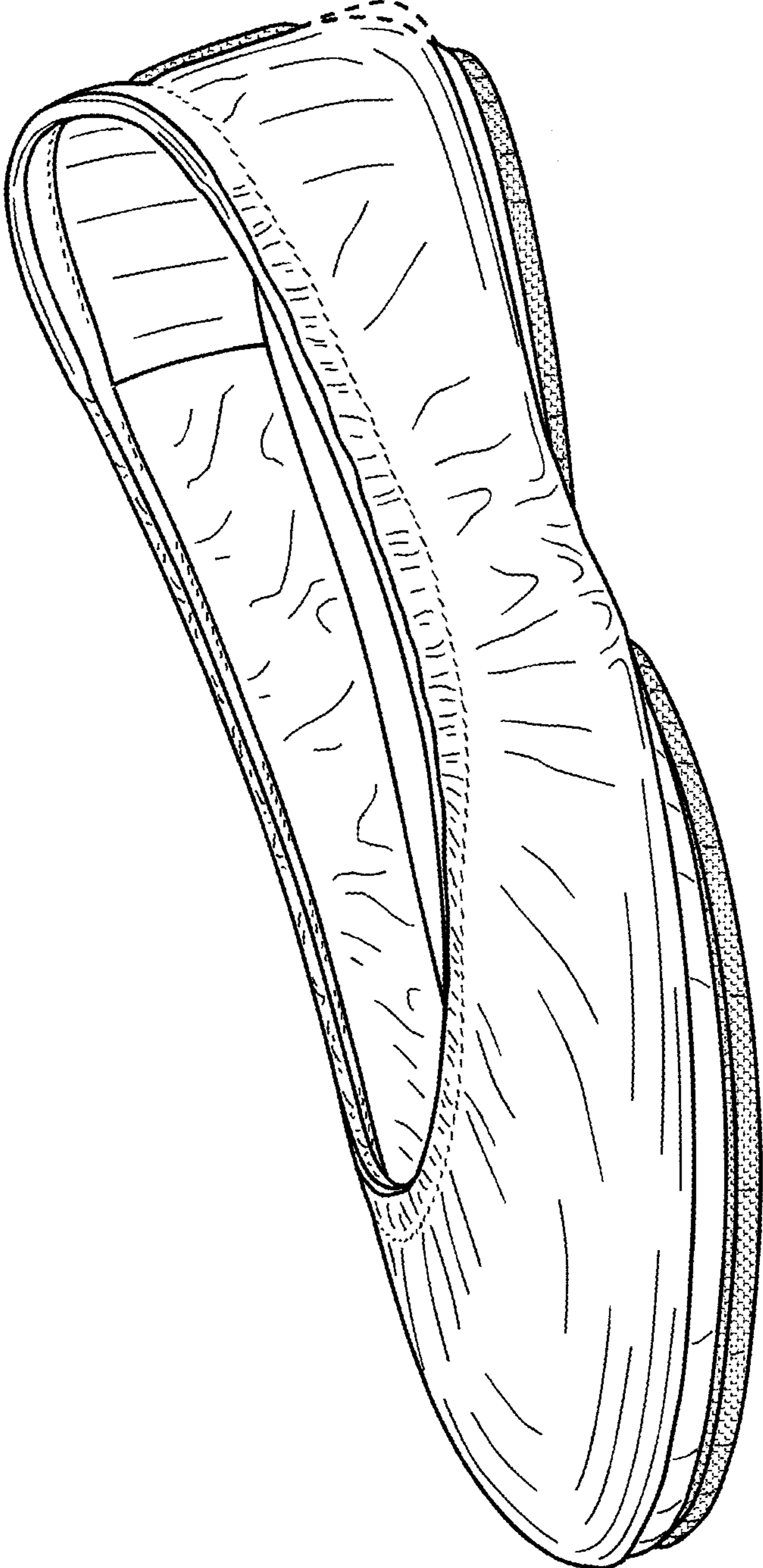

Figure 1

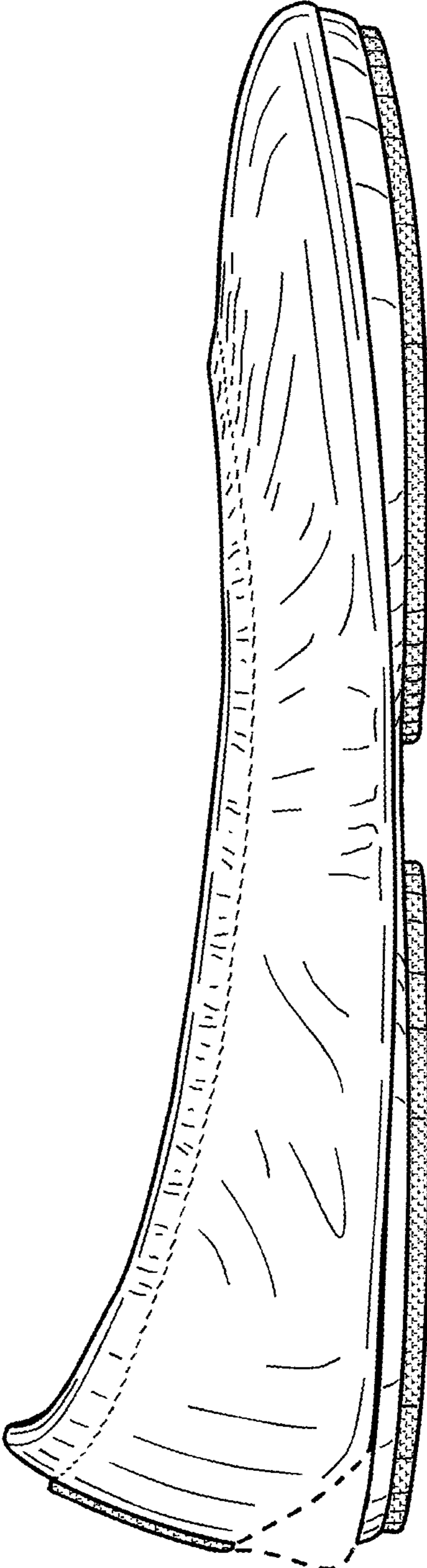

Figure 2

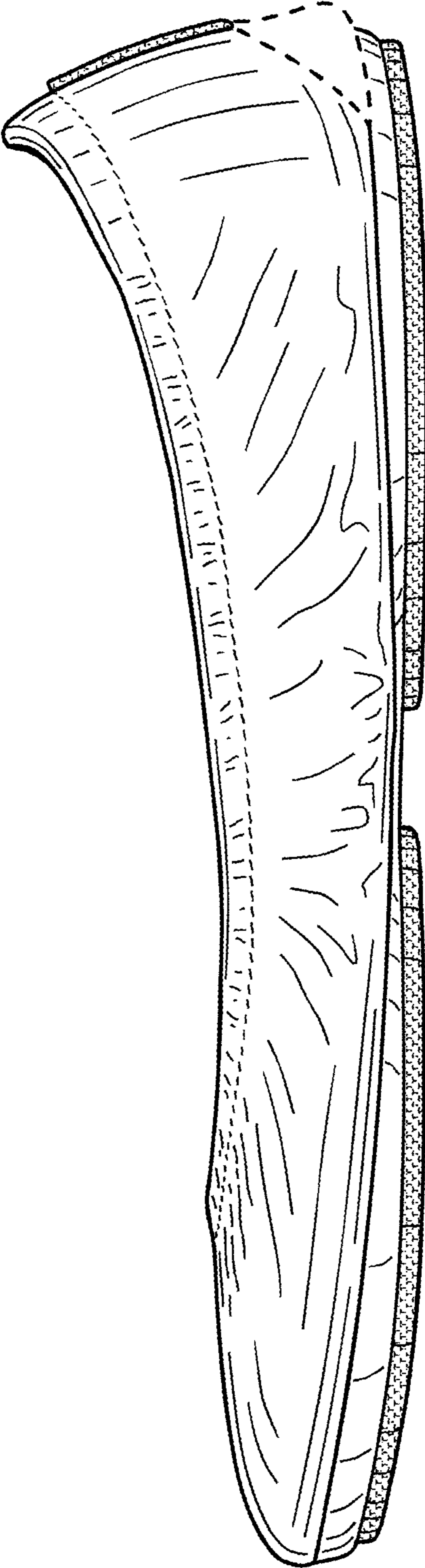

Figure 3

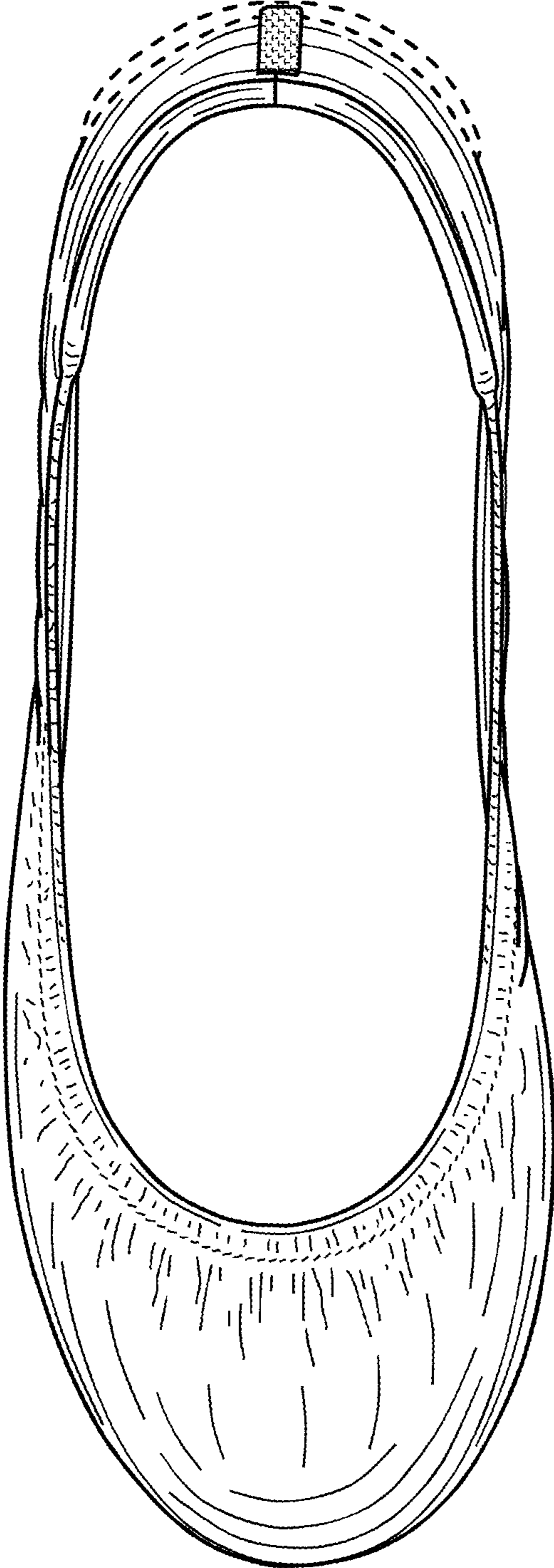

Figure 4

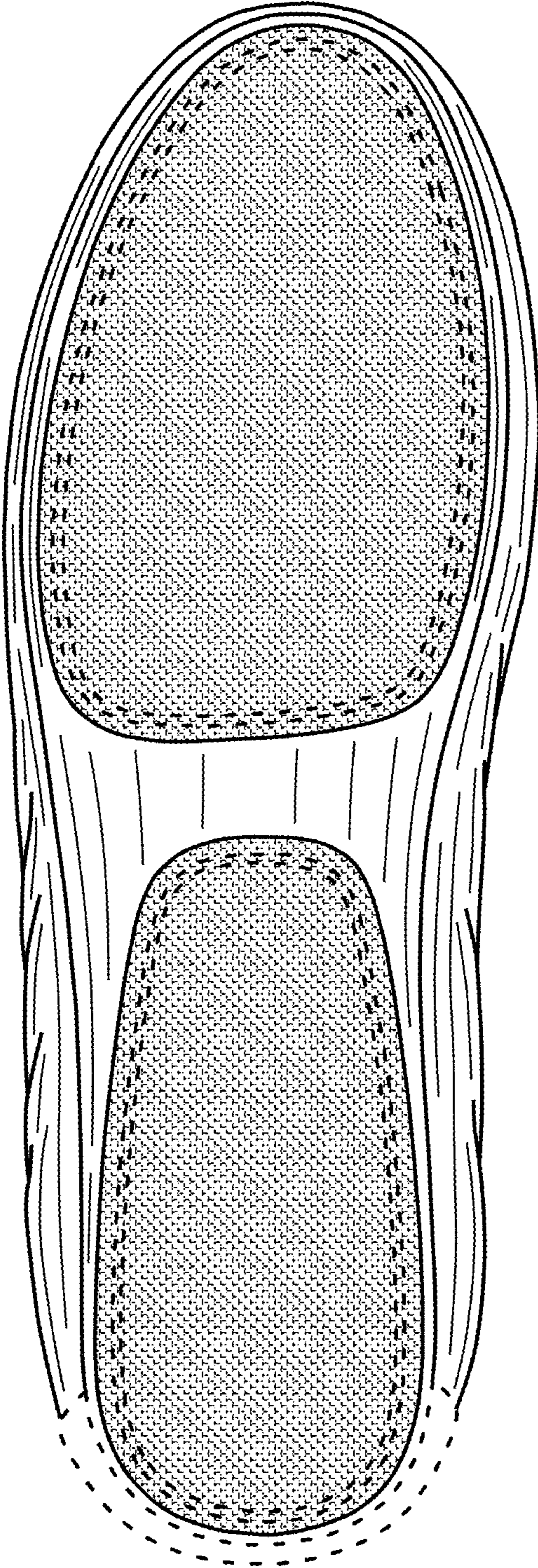

Figure 5

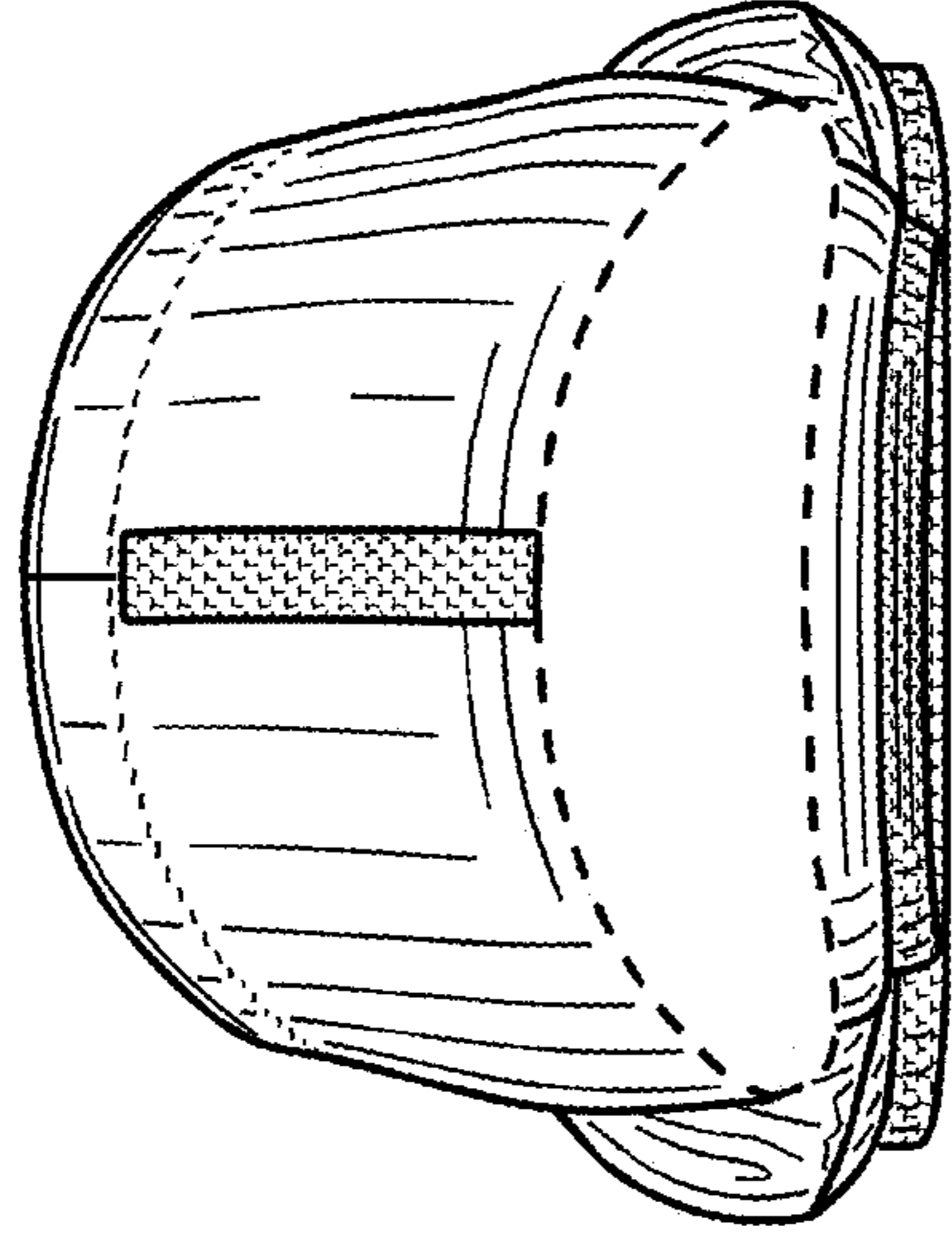

Figure 7

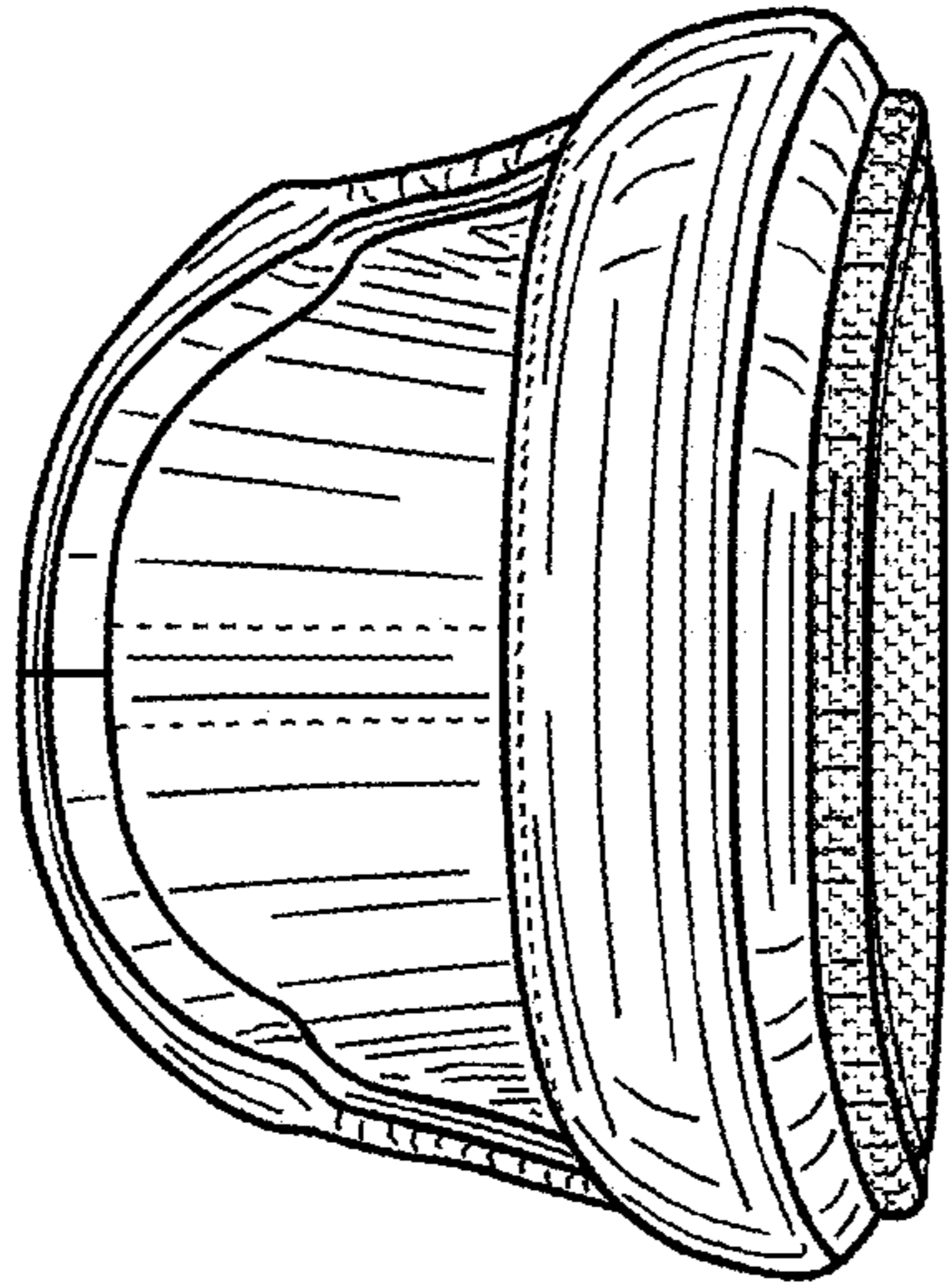

Figure 6