



US00D967996S

(12) **United States Design Patent** (10) **Patent No.:** **US D967,996 S**  
**Wen** (45) **Date of Patent:** **\*\* Oct. 25, 2022**

(54) **MOTORCYCLE TURN INDICATOR LIGHT**

(71) Applicant: **Biling Wen**, Jiangmen (CN)

(72) Inventor: **Biling Wen**, Jiangmen (CN)

(\*\*) Term: **15 Years**

(21) Appl. No.: **29/841,912**

(22) Filed: **Jun. 9, 2022**

(51) **LOC (13) Cl.** ..... **26-06**

(52) **U.S. Cl.**  
USPC ..... **D26/28**

(58) **Field of Classification Search**  
 USPC ..... D26/28, 29, 30, 31, 32, 33, 34, 35, 36  
 CPC ..... F21W 2103/35; F21W 2103/40; F21W  
 2102/17; F21W 2102/30; F21W 2103/00;  
 F21W 2103/55; F21W 2104/00; F21W  
 2107/17; F21W 2107/13; F21S 41/00;  
 F21S 41/141; F21S 41/162; F21S 41/18;  
 F21S 41/20; F21S 41/33; F21S 41/36;  
 F21S 41/60; F21S 43/00; F21V 21/04  
 See application file for complete search history.

(56) **References Cited**

**U.S. PATENT DOCUMENTS**

D346,232 S *	4/1994	Falkensson	.....	D26/28
D423,701 S *	4/2000	Hussaini	.....	D26/28
D423,702 S *	4/2000	Hussaini	.....	D26/28
D424,220 S *	5/2000	Hussaini	.....	D26/28
D440,330 S *	4/2001	Scott	.....	D26/28

D463,048 S *	9/2002	Scott	.....	D26/28
D501,939 S	2/2005	Jacobs et al.		
D575,424 S *	8/2008	Gebhard	.....	D26/28
D597,237 S *	7/2009	Kumthampinij	.....	D26/39
D667,581 S *	9/2012	Lee	.....	D26/60
D734,517 S	7/2015	Rigolio		
D923,215 S *	6/2021	Wang	.....	D26/28
D960,408 S *	8/2022	Zhang	.....	D26/28

\* cited by examiner

*Primary Examiner* — Angela J Lee

(74) *Attorney, Agent, or Firm* — Daniel M. Cohn;  
Howard M. Cohn

(57) **CLAIM**

The ornamental design for a motorcycle turn indicator light, as shown and described.

**DESCRIPTION**

FIG. 1 is a perspective view of a motorcycle turn indicator light showing my new design;  
 FIG. 2 is another perspective view thereof;  
 FIG. 3 is a front elevational view thereof;  
 FIG. 4 is a rear elevational view thereof;  
 FIG. 5 is a left side elevational view thereof;  
 FIG. 6 is a right side elevational view thereof;  
 FIG. 7 is a top plan view thereof; and,  
 FIG. 8 is a bottom plan view thereof.  
 The dash-dash broken lines in the drawings depict portions of the motorcycle turn indicator light that form no part of the claimed design.

**1 Claim, 8 Drawing Sheets**

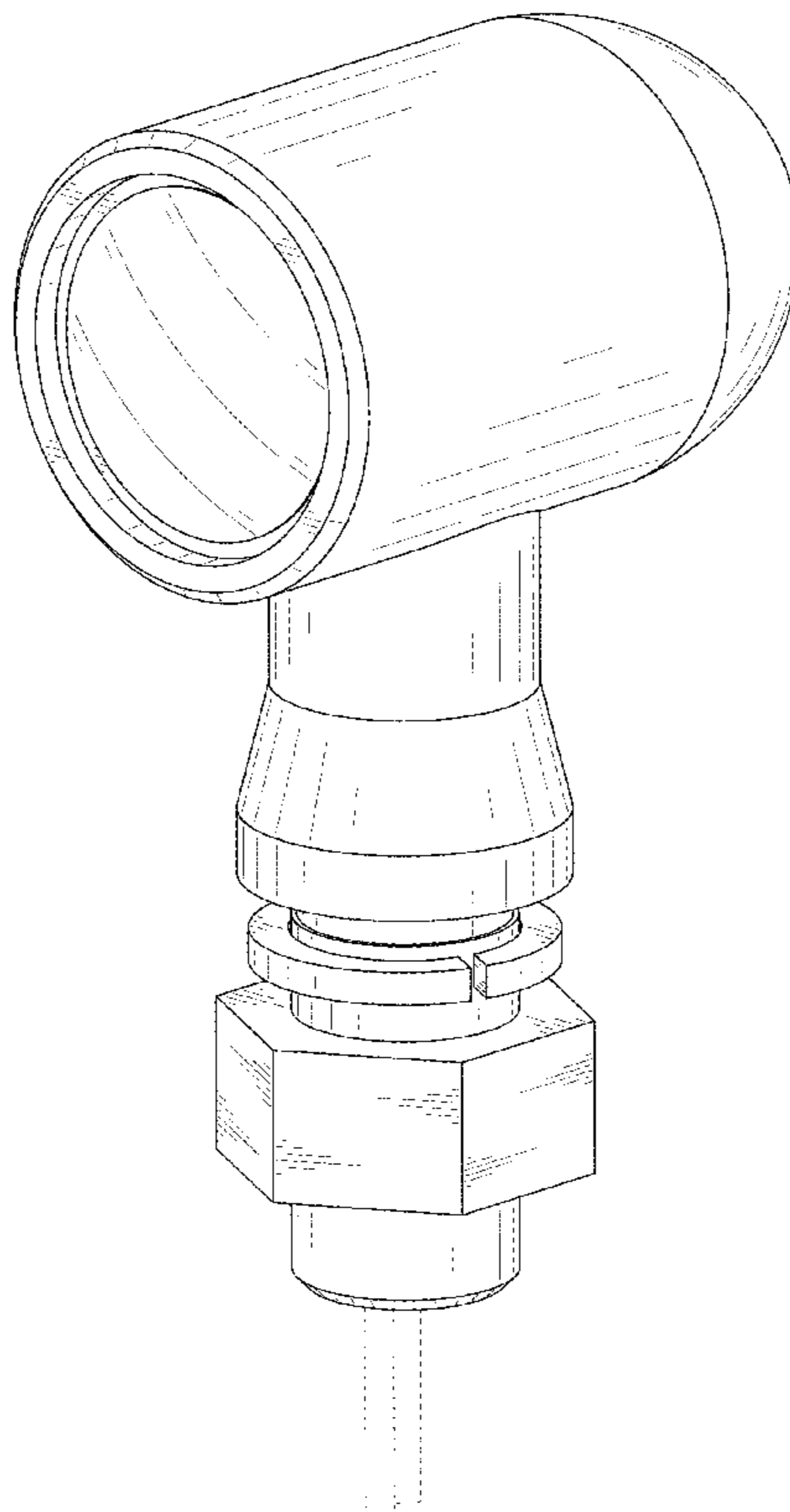

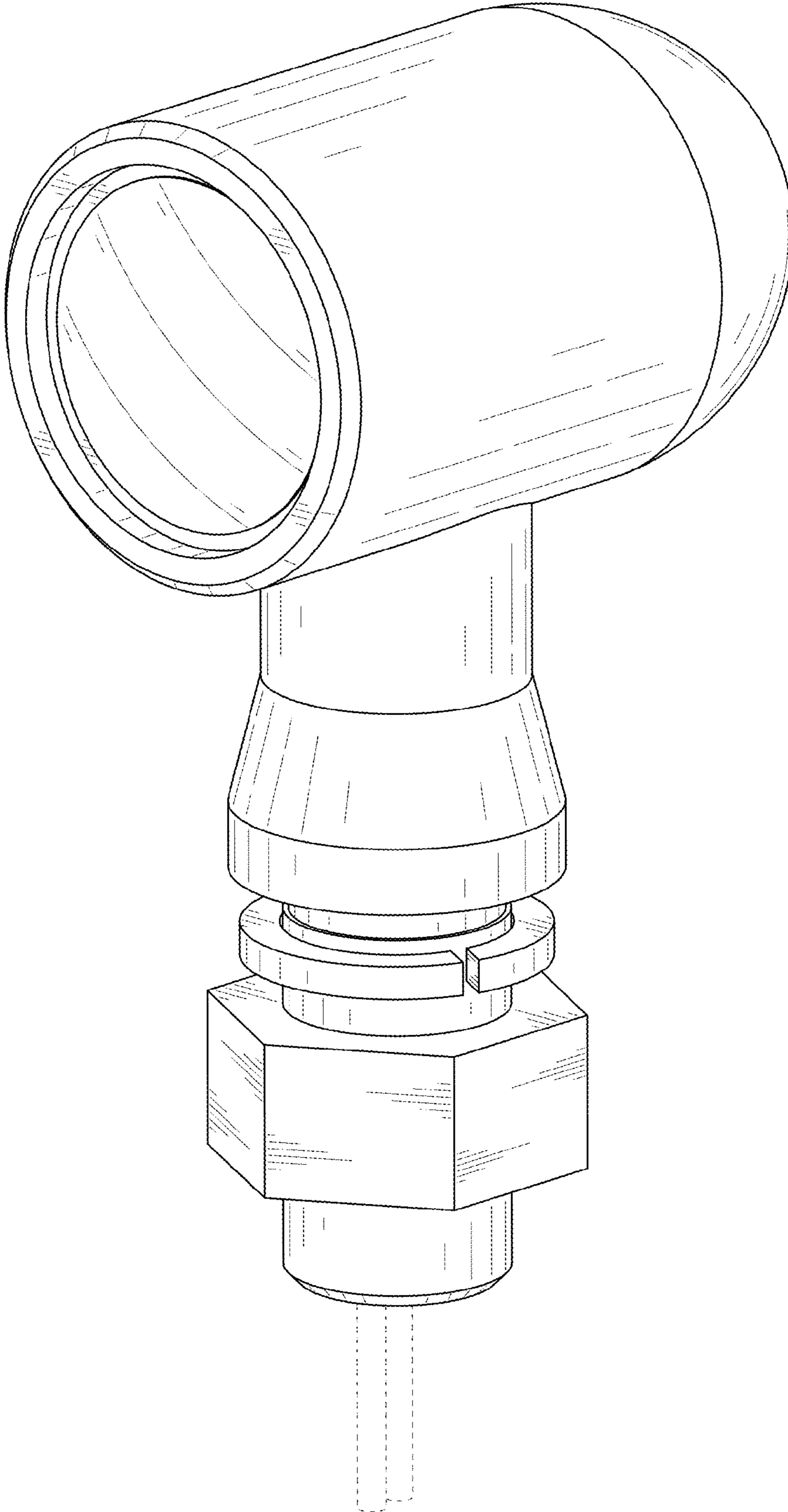

FIG. 1

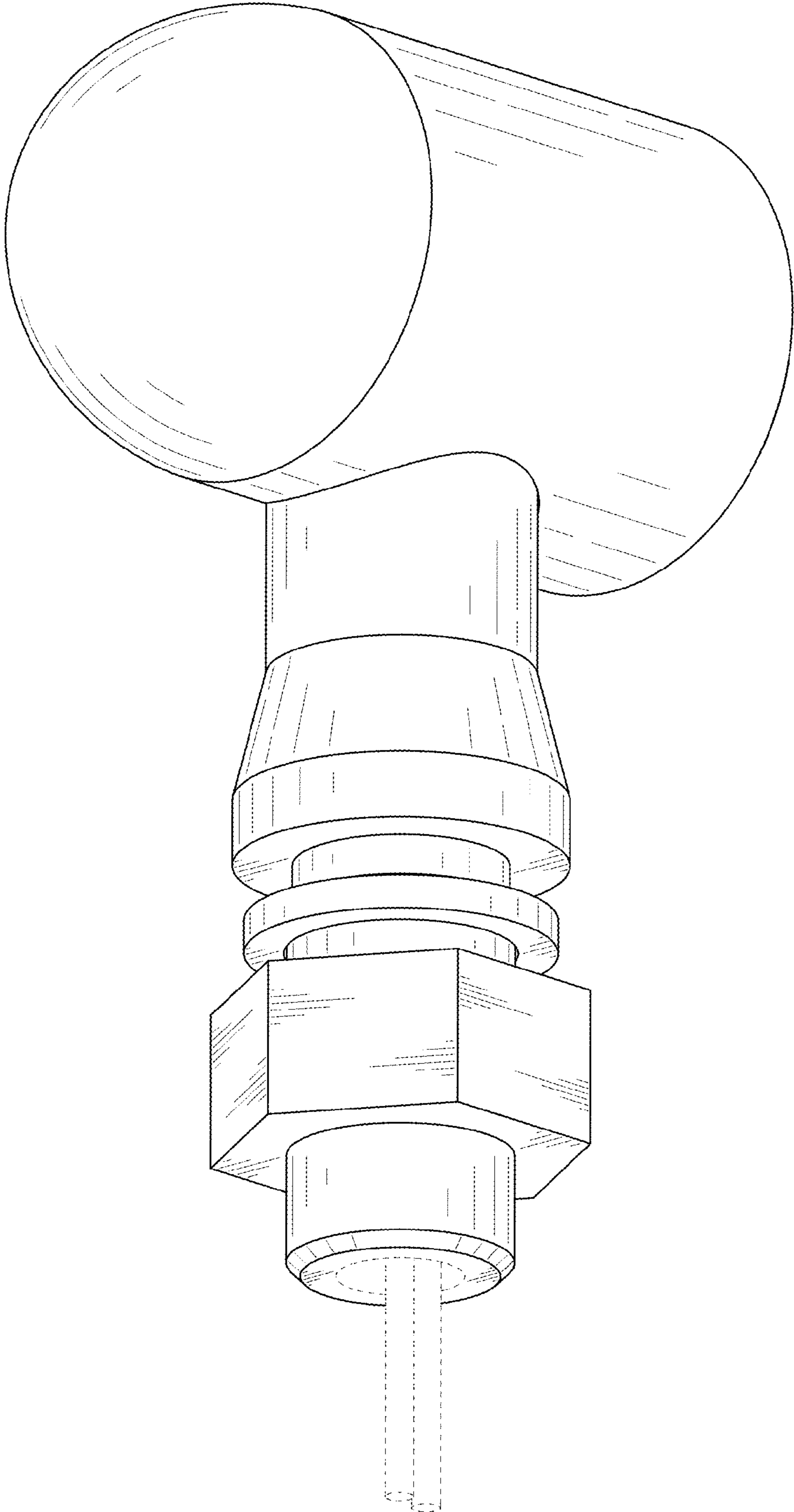

FIG. 2

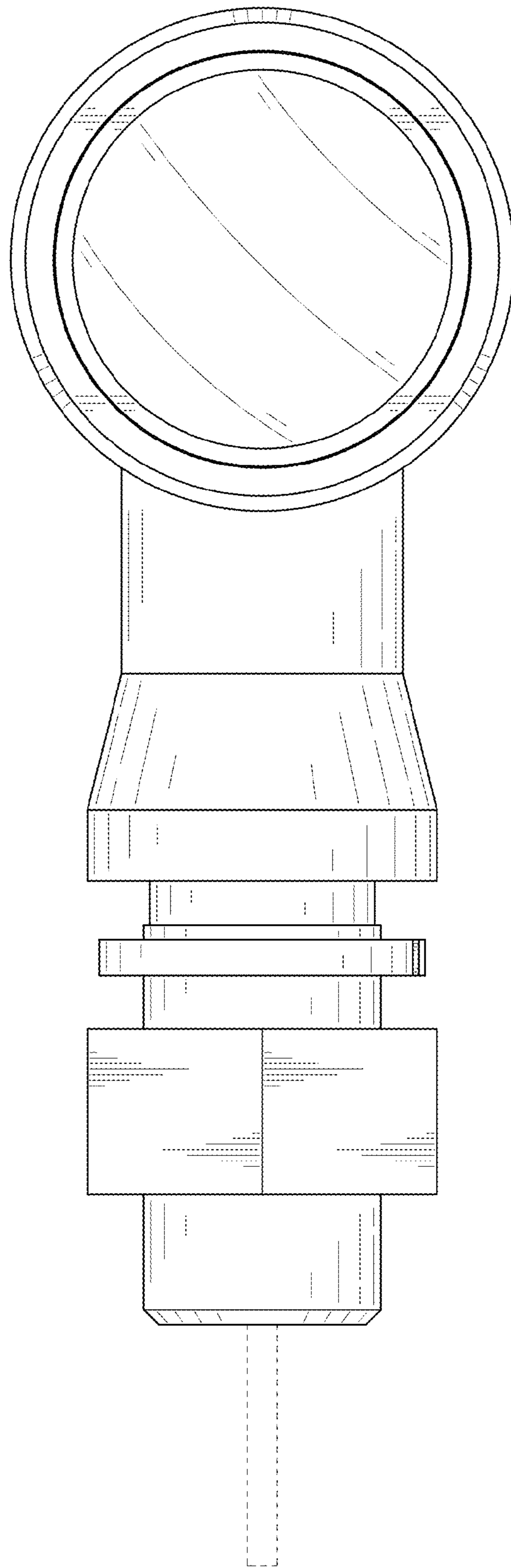

FIG. 3

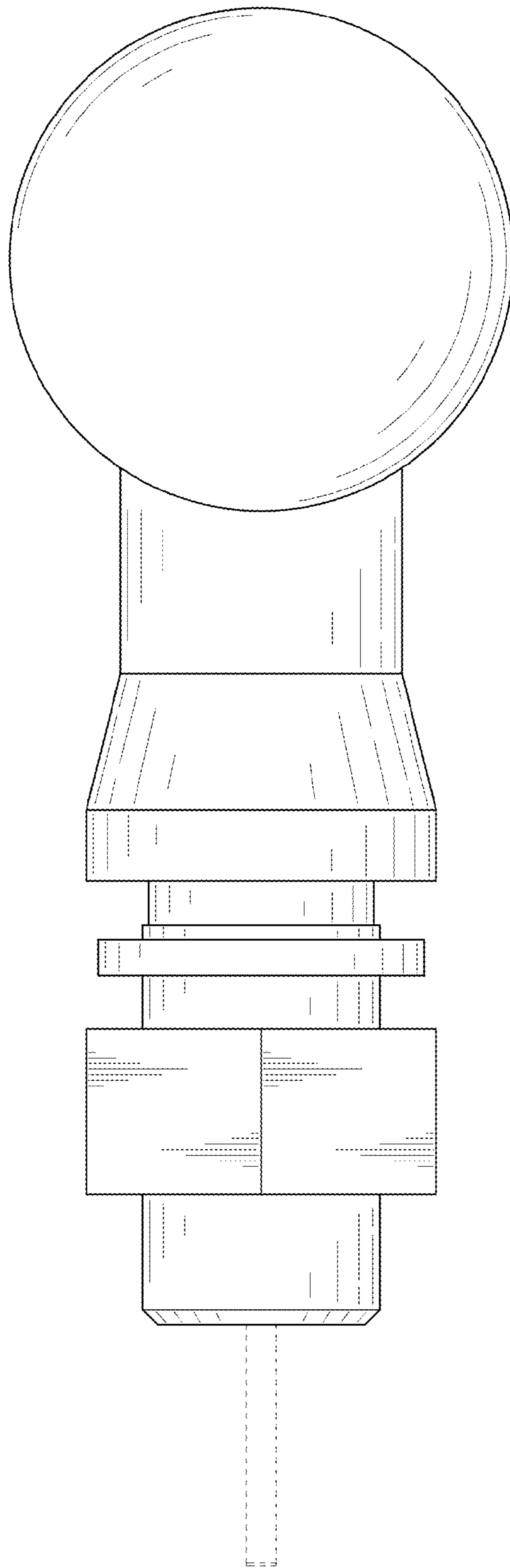

FIG. 4

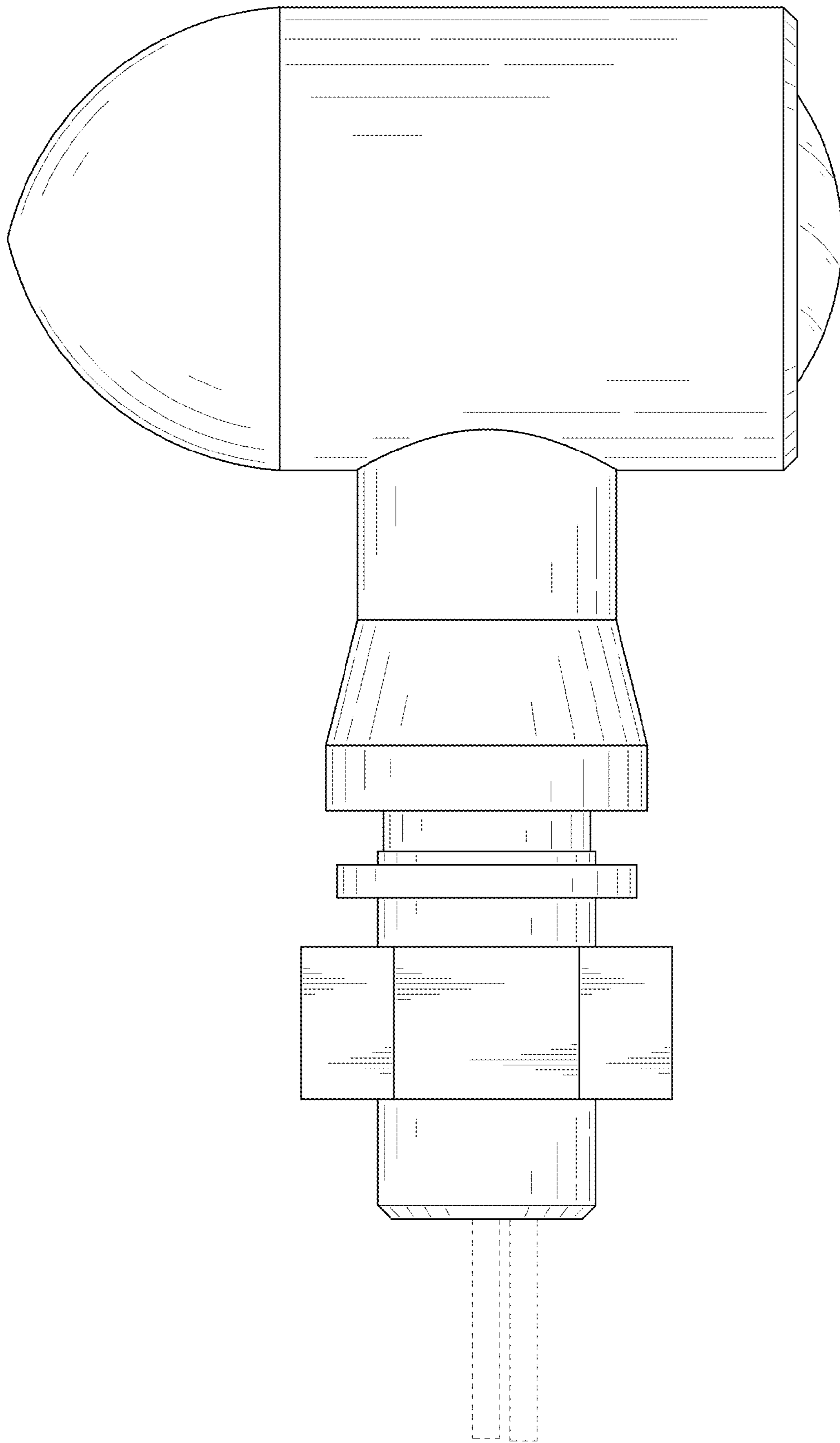

FIG. 5

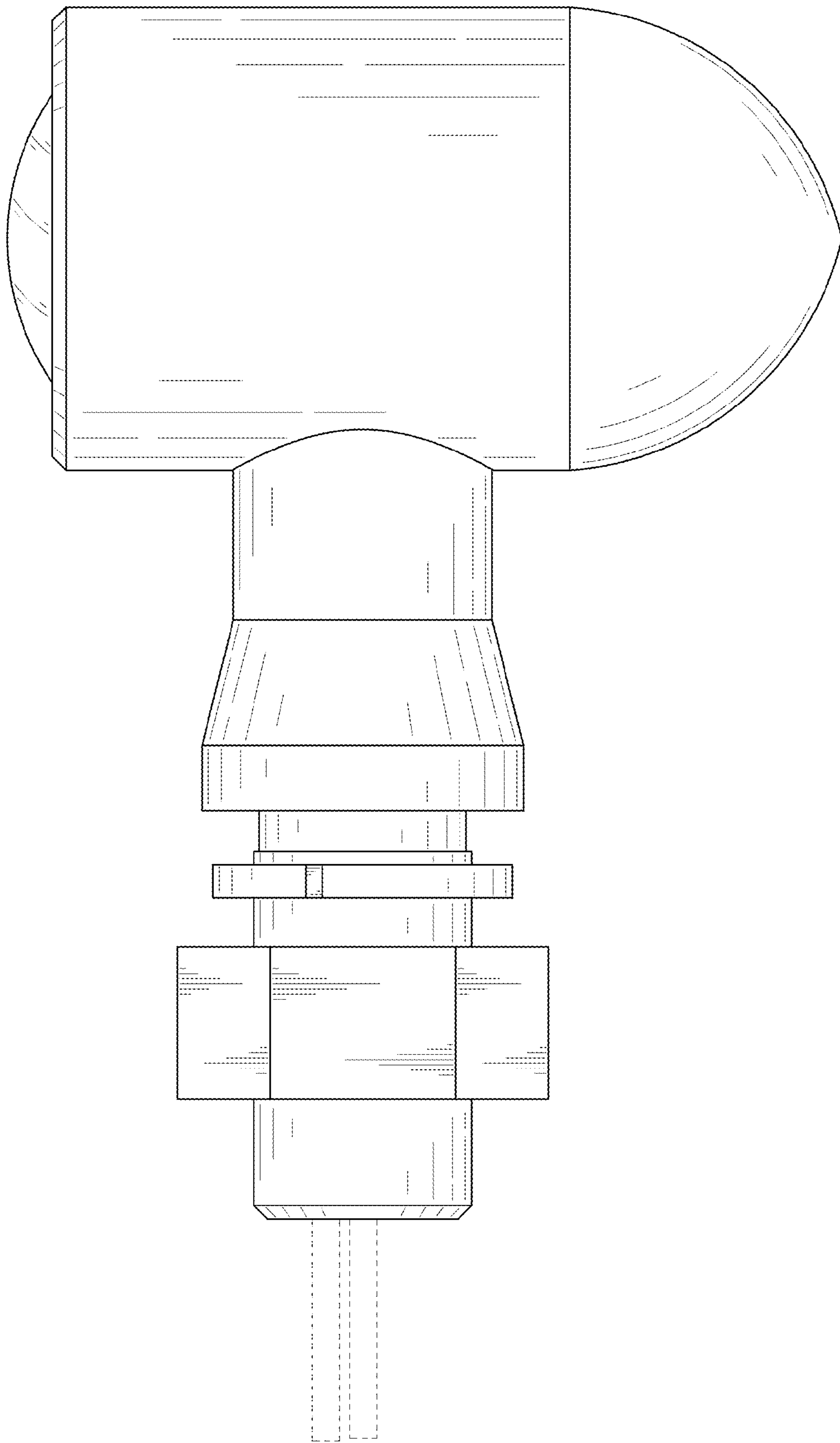

FIG. 6

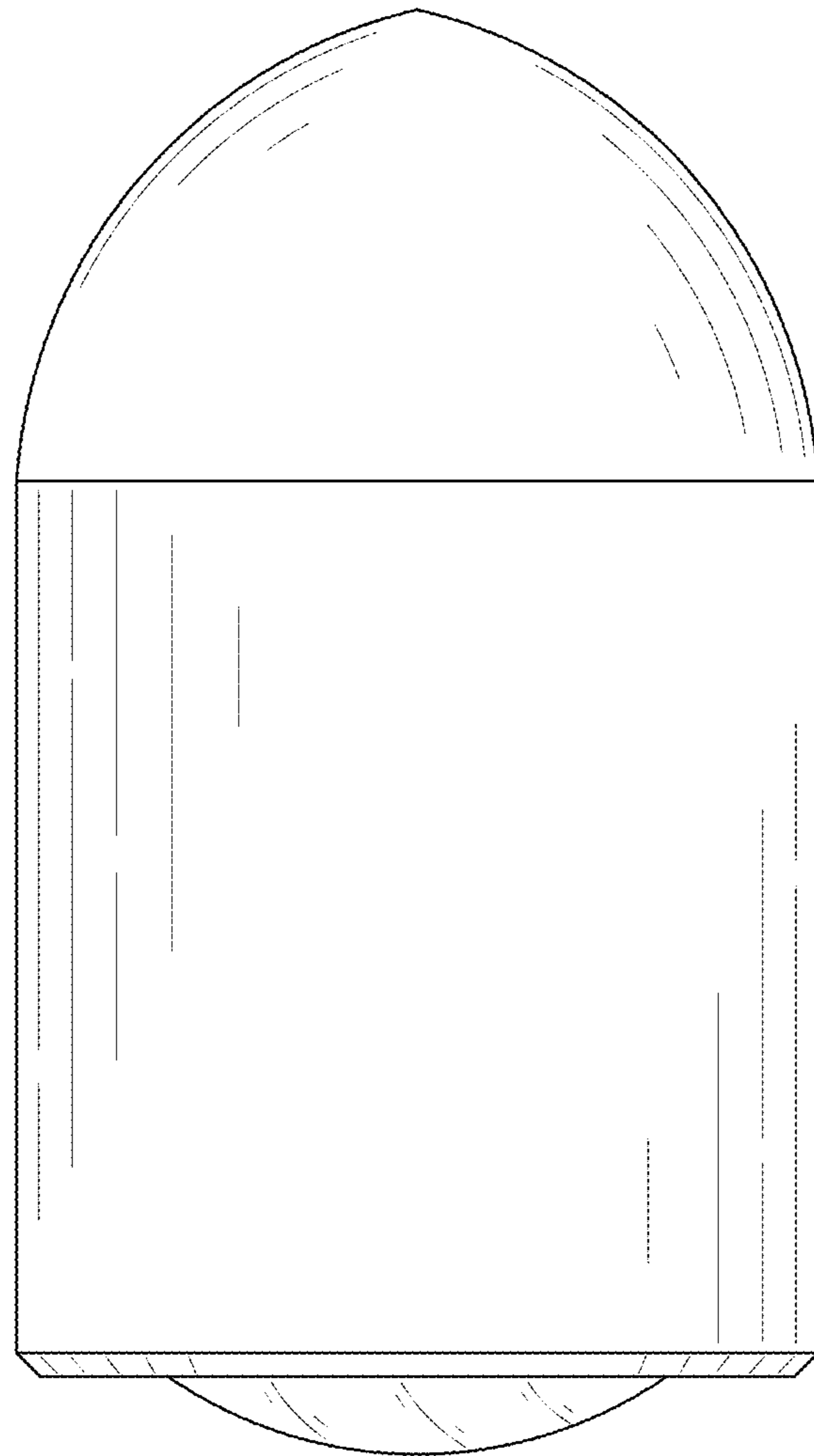

FIG. 7



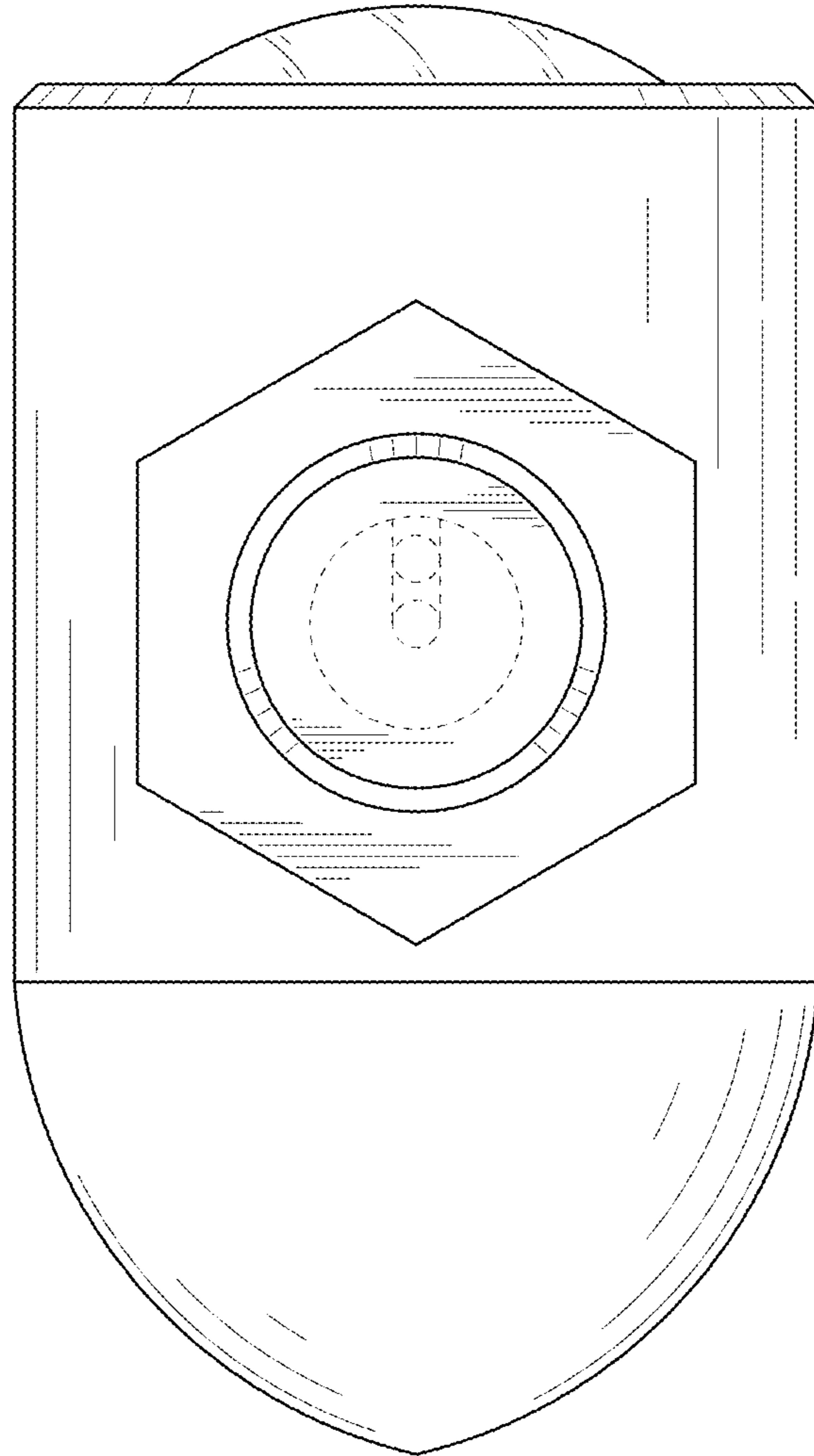

FIG. 8