



US00D967864S

(12) **United States Design Patent**  
**Sperry et al.**

(10) **Patent No.:** **US D967,864 S**  
(45) **Date of Patent:** **\*\* Oct. 25, 2022**

(54) **EXHAUST GAS AFTERTREATMENT SYSTEM**

10,508,579 B2 12/2019 Fischer et al.  
10,934,918 B1 \* 3/2021 Goffe ..... B01D 53/9427  
2006/0207757 A1 \* 9/2006 Danielsson ..... F28F 1/426  
165/159  
2010/0083643 A1 \* 4/2010 Hayashi ..... F01N 3/2066  
60/297

(71) Applicant: **Cummins Emission Solutions Inc.**,  
Columbus, IN (US)

(72) Inventors: **Robert G. Sperry**, Columbus, IN (US);  
**Chetan Kishor Rao Chawane**, Pune (IN); **Karan Shaileshkumar Chinaiwala**, Surat (IN); **Enoch Nanduru**, Pune (IN)

(73) Assignee: **Cummins Emission Solutions Inc.**,  
Columbus, IN (US)

(\*\*) Term: **15 Years**

(21) Appl. No.: **29/820,169**

(22) Filed: **Dec. 20, 2021**

(51) **LOC (13) Cl.** ..... **15-01**

(52) **U.S. Cl.**  
USPC ..... **D15/5**

(58) **Field of Classification Search**  
USPC ..... D15/4, 5, 148, 143; D12/194  
CPC ..... F28D 21/0003; B01D 53/9431; B01D 53/944; F02M 26/22; F02M 26/28; F02M 26/29; F02M 26/32; B01J 19/26; B01J 19/1862

See application file for complete search history.

(56) **References Cited**

U.S. PATENT DOCUMENTS

1,824,078 A \* 9/1931 Fischer ..... B01D 53/944  
60/299  
D247,360 S \* 2/1978 Hamaguchi ..... D12/194  
7,077,102 B1 7/2006 Stowe  
D702,735 S \* 4/2014 Sandou ..... D15/5  
9,920,676 B2 \* 3/2018 Freeman ..... B01D 53/944  
9,957,868 B2 5/2018 Johnson

(Continued)

FOREIGN PATENT DOCUMENTS

EP 2 944 371 A1 11/2015  
JP 2014-223610 A 12/2014

Primary Examiner — Ania Aman

(74) Attorney, Agent, or Firm — Foley & Lardner LLP

(57) **CLAIM**

We claim the ornamental design for an exhaust gas after-treatment system, as shown and described.

**DESCRIPTION**

FIG. 1 is a front, top, left side perspective view of the exhaust gas aftertreatment system showing our new design; FIG. 2 is a rear, top, right side perspective view of the exhaust gas aftertreatment system; FIG. 3 is a front view of the exhaust gas aftertreatment system; FIG. 4 is a rear view of the exhaust gas aftertreatment system; FIG. 5 is a left side view of the exhaust gas aftertreatment system; FIG. 6 is a right side view of the exhaust gas aftertreatment system; FIG. 7 is a top view of the exhaust gas aftertreatment system; and, FIG. 8 is a bottom view of the exhaust gas aftertreatment system. The broken lines depict portions of the exhaust gas after-treatment system that form no part of the claimed design.

**1 Claim, 7 Drawing Sheets**

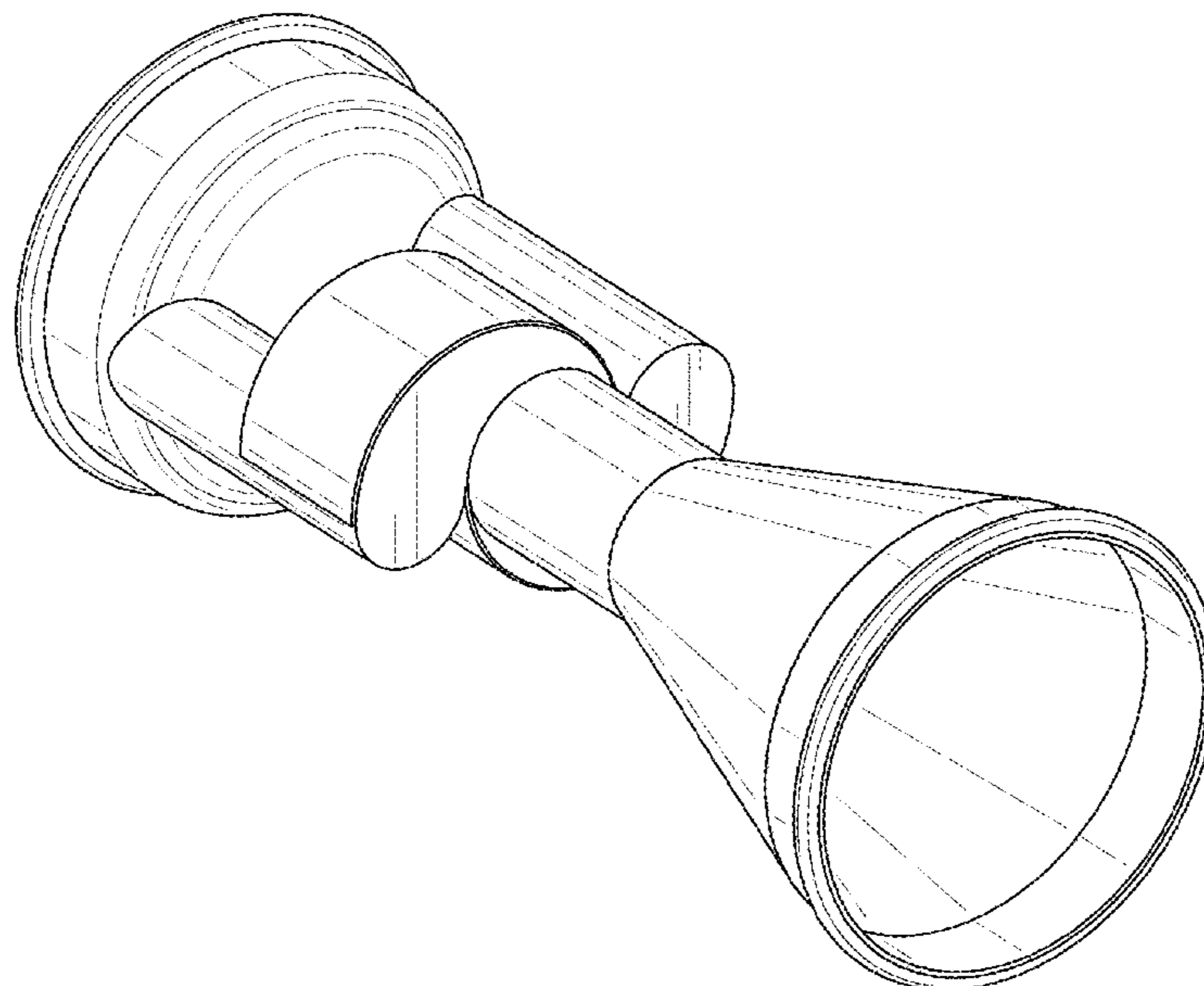

(56)

**References Cited**

U.S. PATENT DOCUMENTS

2012/0048246 A1\* 3/2012 Takagi ..... F02M 26/06  
123/568.15  
2014/0056767 A1\* 2/2014 Bedard ..... C07C 2/78  
422/128

\* cited by examiner

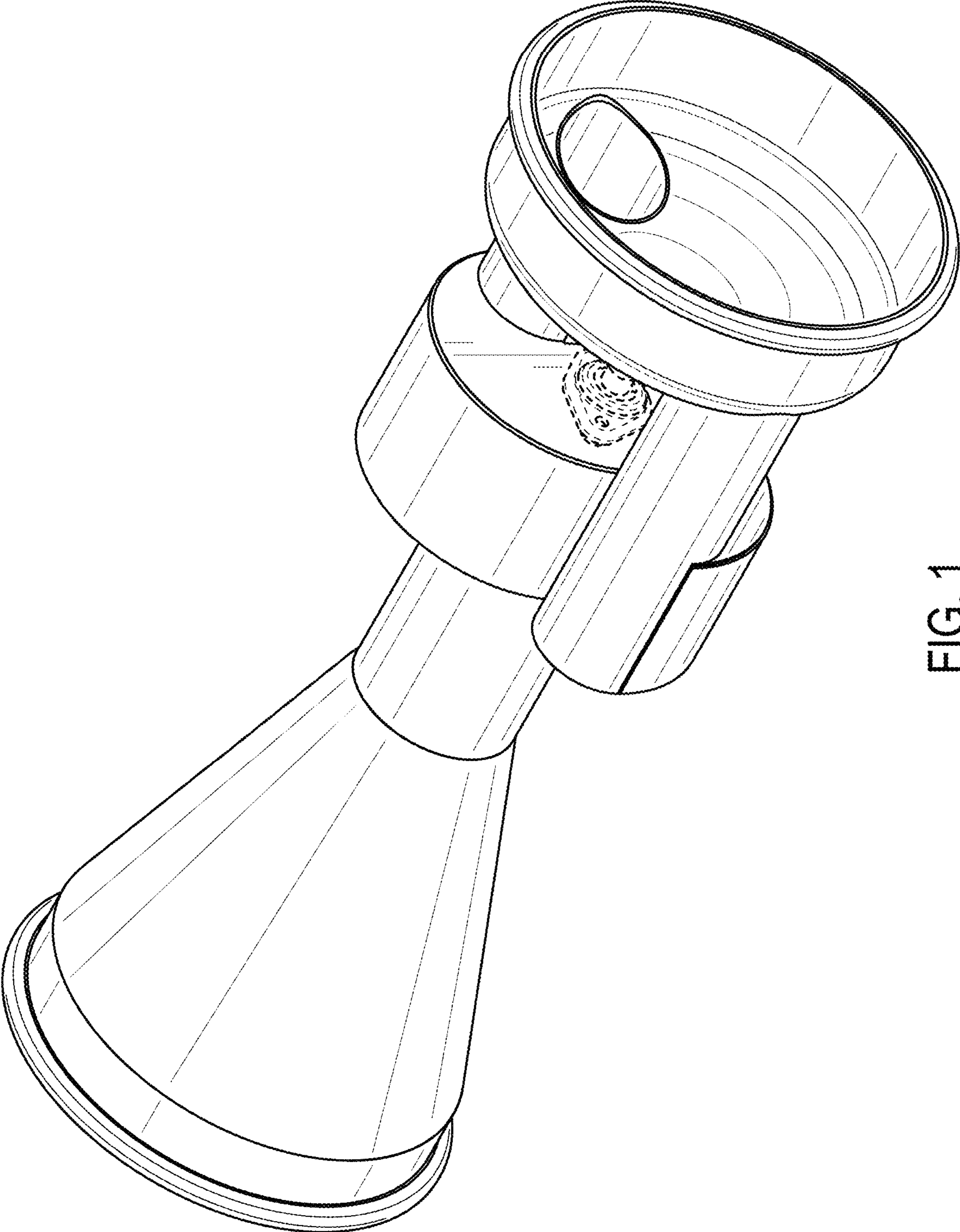

FIG. 1

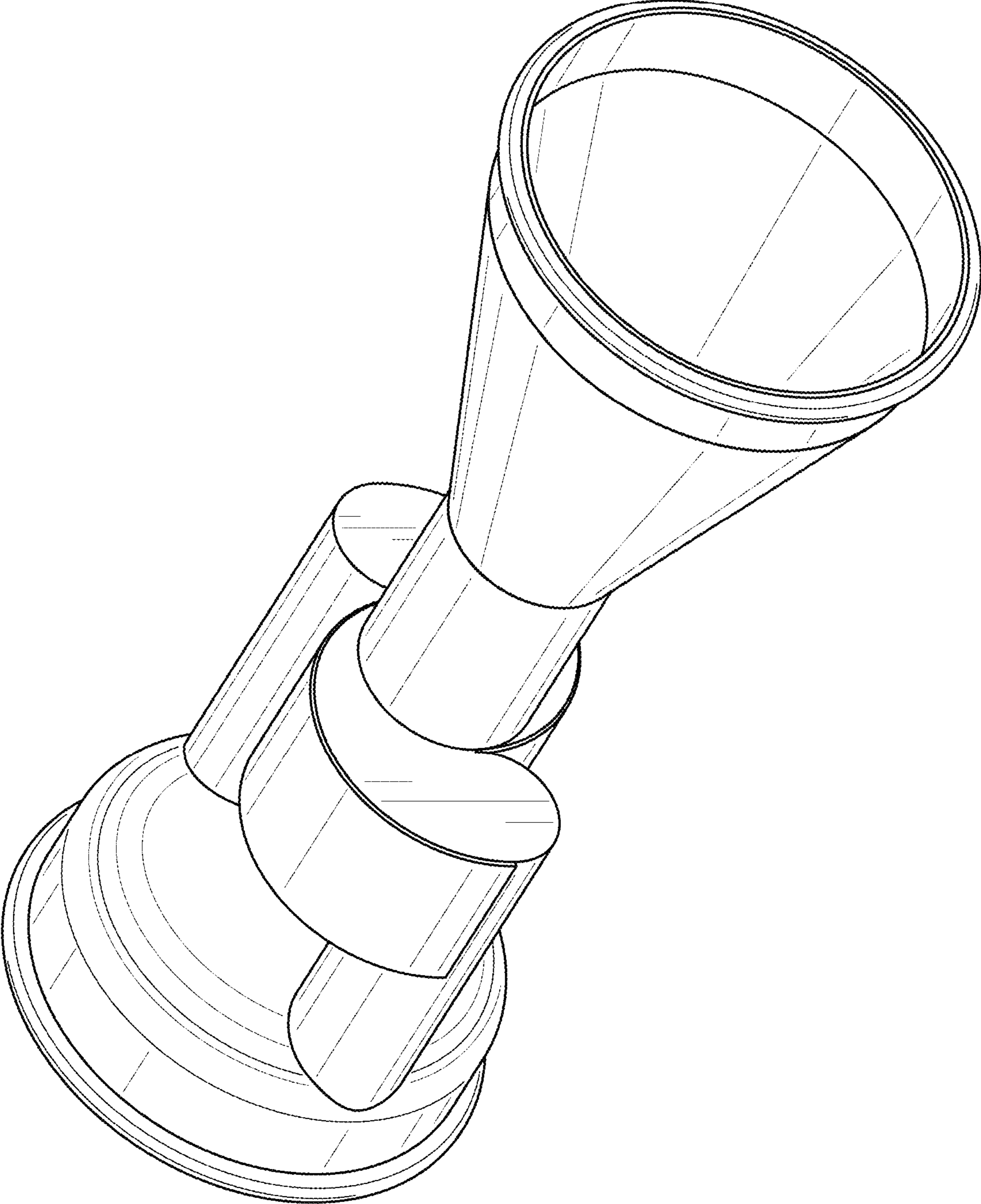

FIG. 2

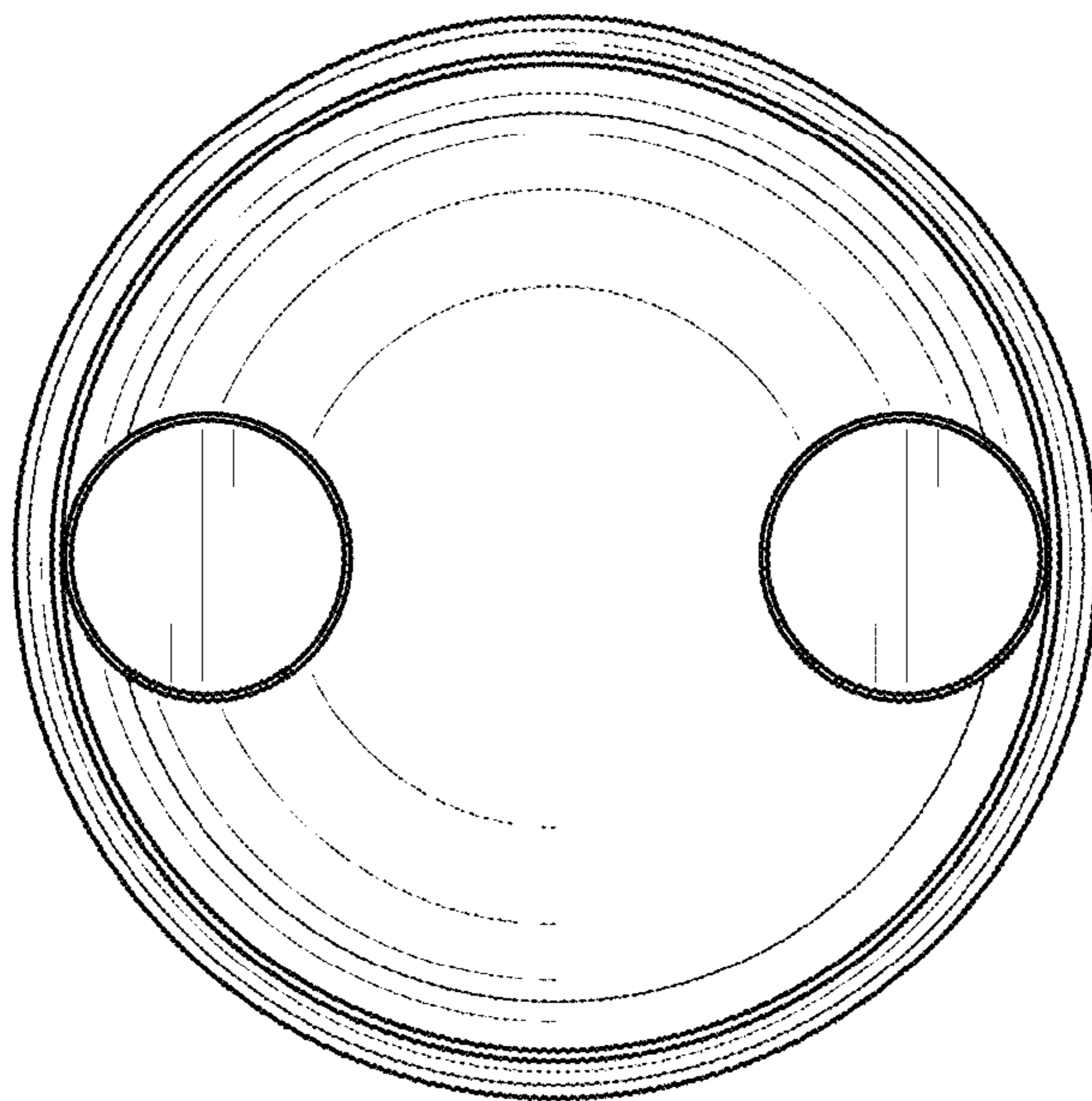

FIG. 3

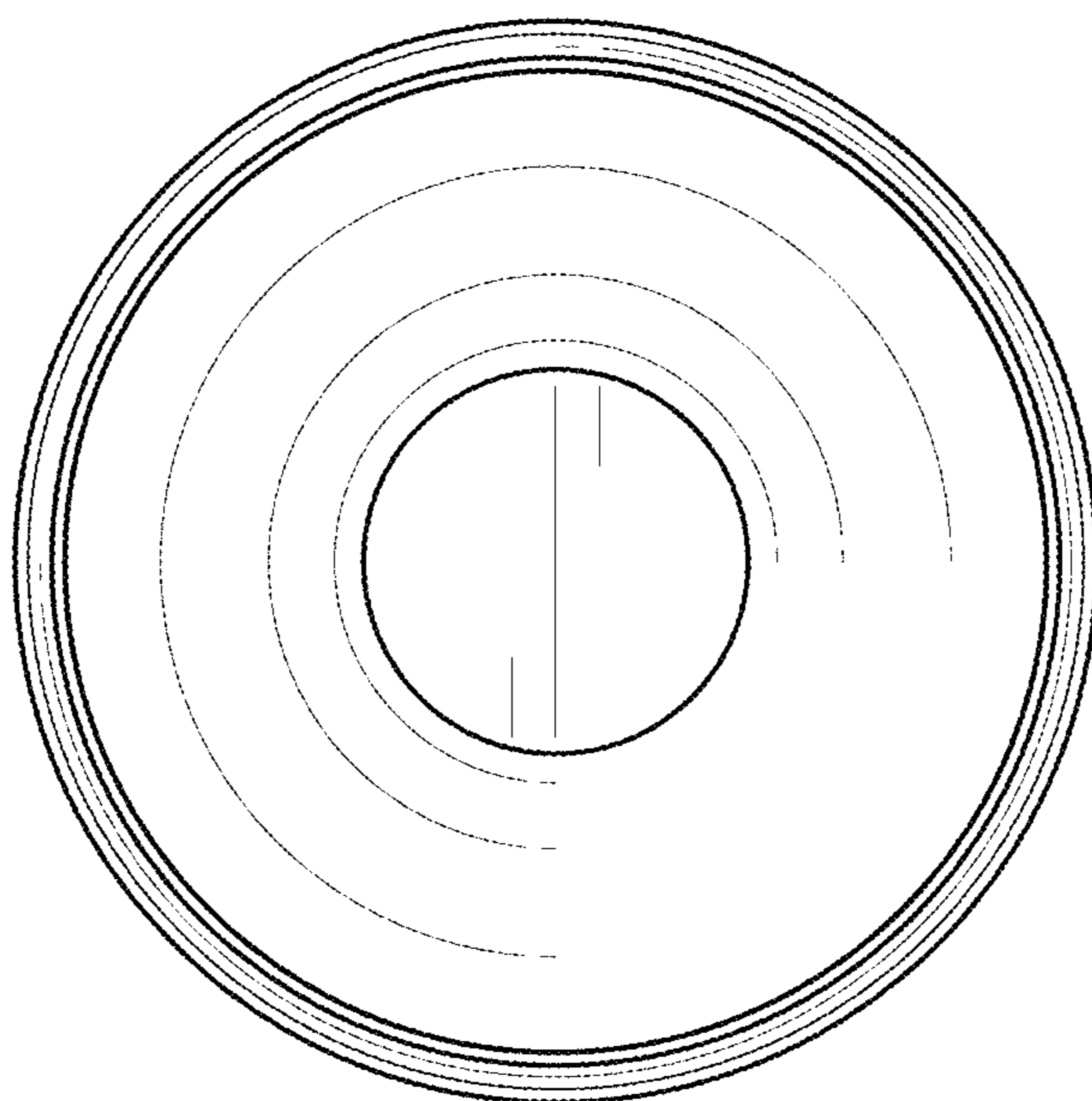

FIG. 4

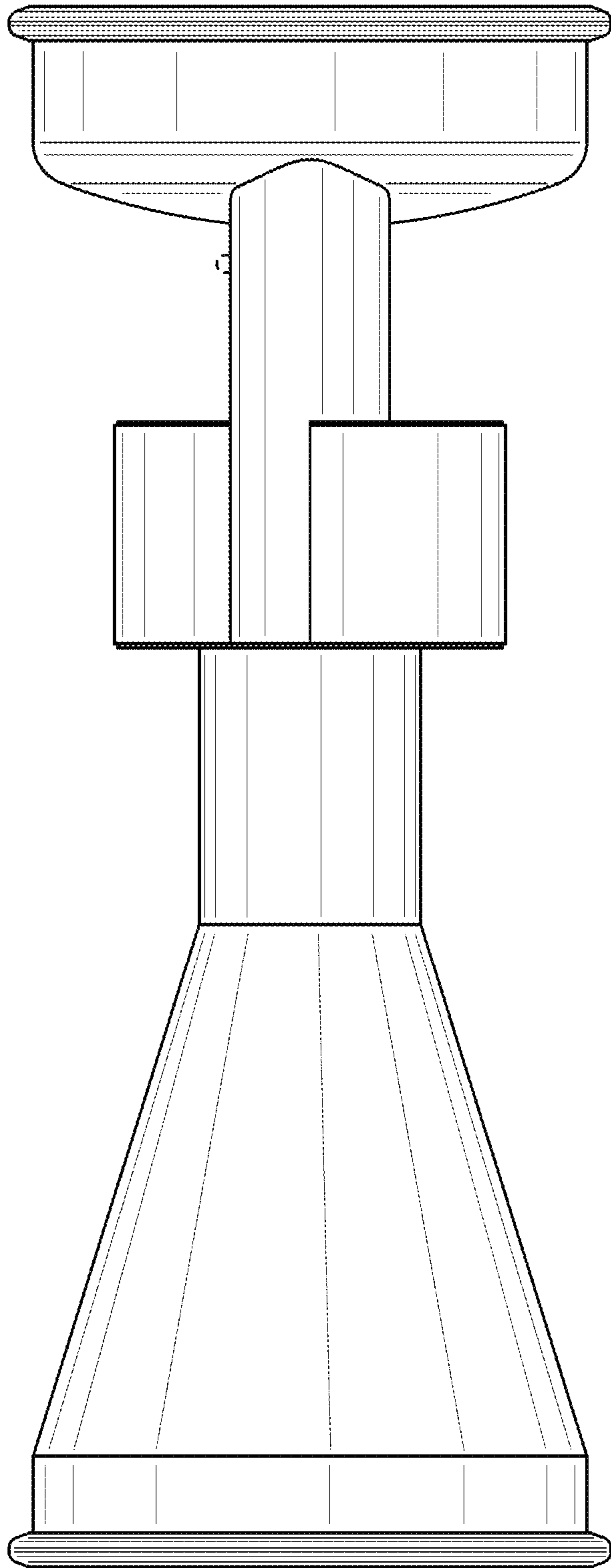

FIG. 5

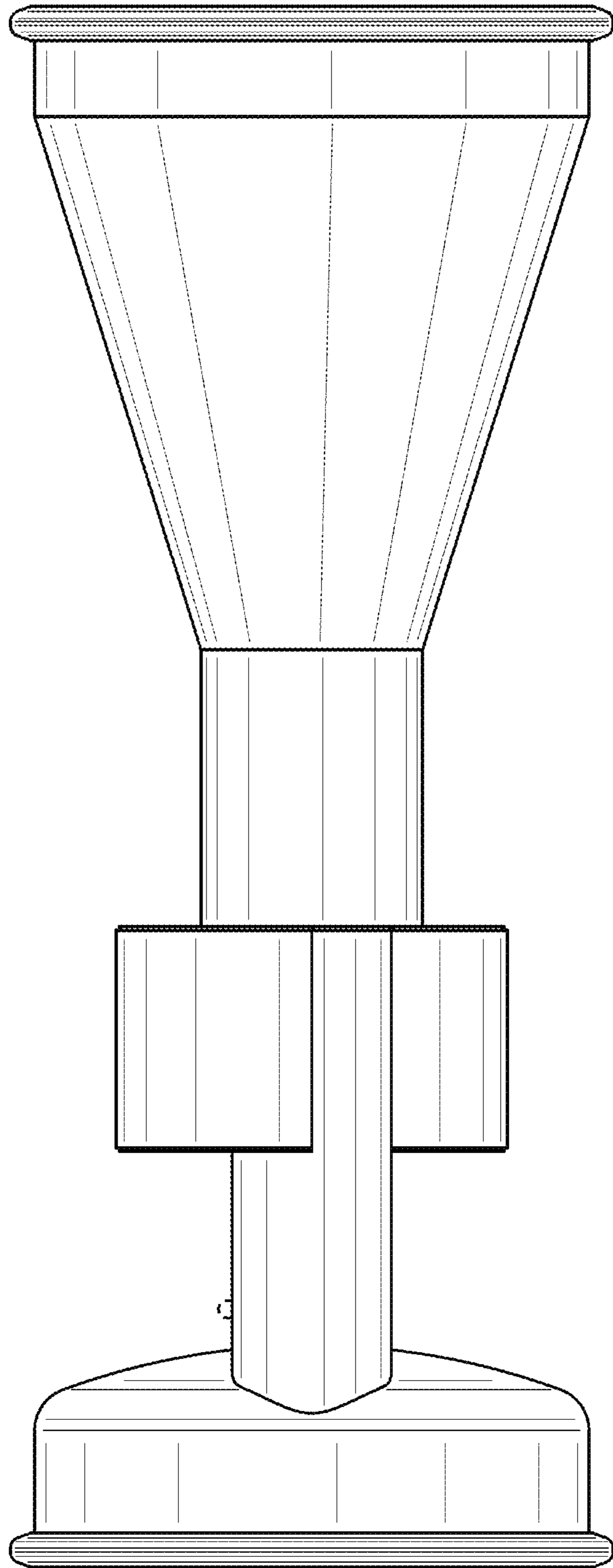

FIG. 6

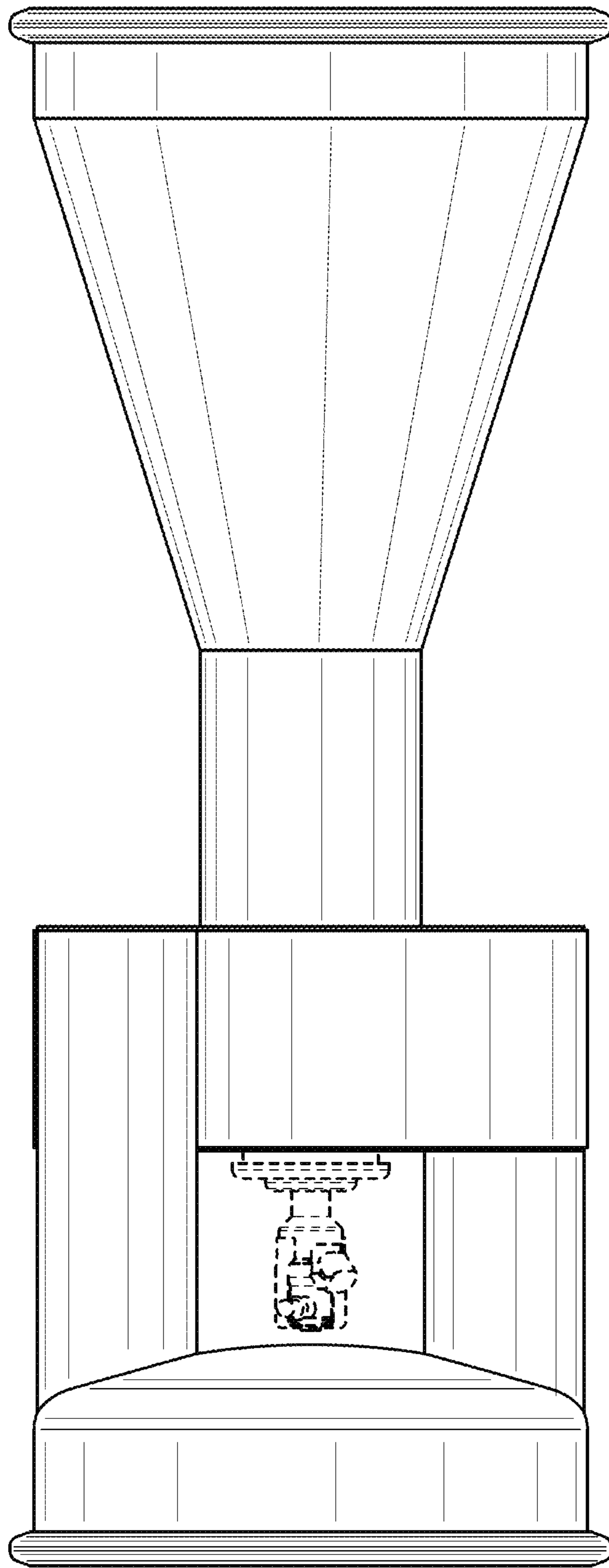

FIG. 7



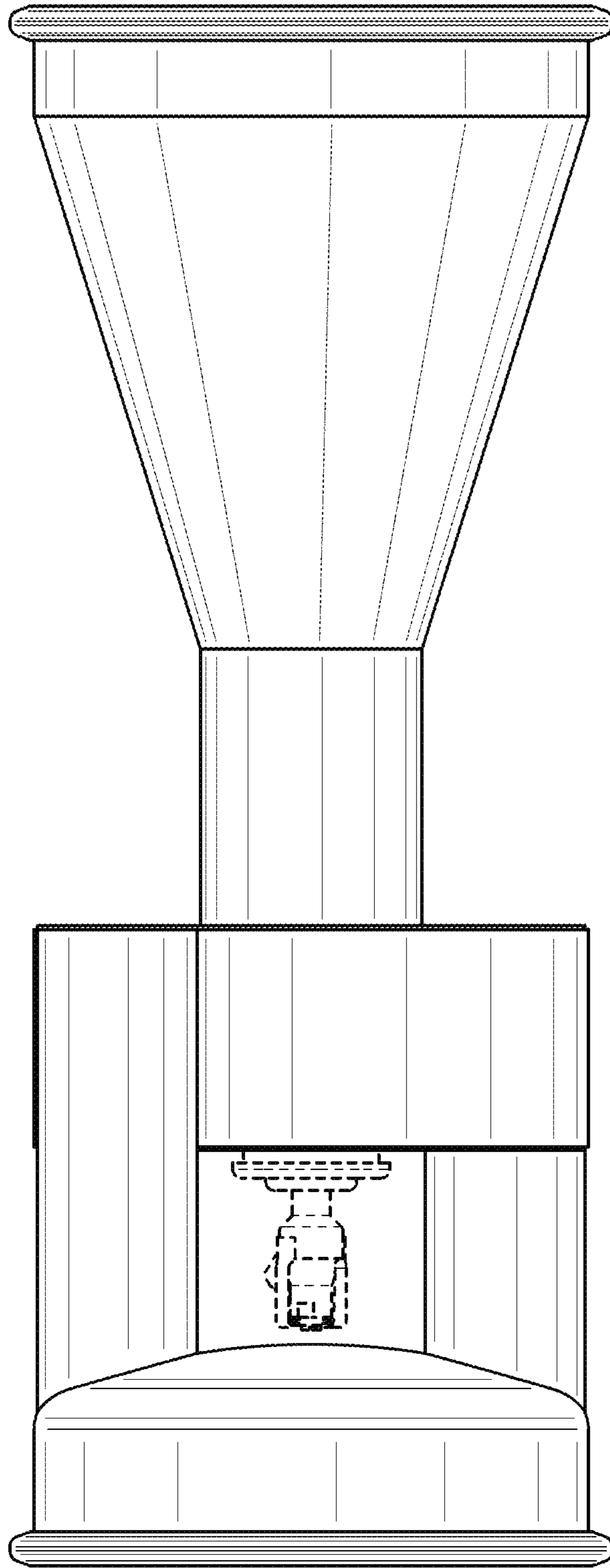

FIG. 8