



US00D967194S

(12) **United States Design Patent**  
**Webb**

(10) **Patent No.:** **US D967,194 S**  
(45) **Date of Patent:** **\*\* Oct. 18, 2022**

(54) **VEHICLE FLUID LINE CONNECTOR BODY**

**DESCRIPTION**

- (71) Applicant: **Norma U.S. Holding LLC**, Auburn Hills, MI (US)
- (72) Inventor: **Mark Richard Webb**, Clarkston, MI (US)
- (73) Assignee: **Norma U.S. Holding LLC**, Auburn Hills, MI (US)
- (\*\*) Term: **15 Years**
- (21) Appl. No.: **29/731,299**
- (22) Filed: **Apr. 14, 2020**
- (51) **LOC (13) Cl.** ..... **15-01**
- (52) **U.S. Cl.**  
USPC ..... **D15/5**
- (58) **Field of Classification Search**  
USPC .... D23/206, 221, 249, 259; D15/81, 2, 3, 4, D15/5, 6, 7  
CPC ..... F16L 37/00; F16L 37/0841  
See application file for complete search history.

(56) **References Cited**

**U.S. PATENT DOCUMENTS**

- D934,300 S \* 10/2021 Webb ..... D15/5
- 11,306,857 B2 \* 4/2022 Baudoin ..... F16L 55/07

\* cited by examiner

*Primary Examiner* — Gino Colan

(74) *Attorney, Agent, or Firm* — Reising Ethington, P.C.

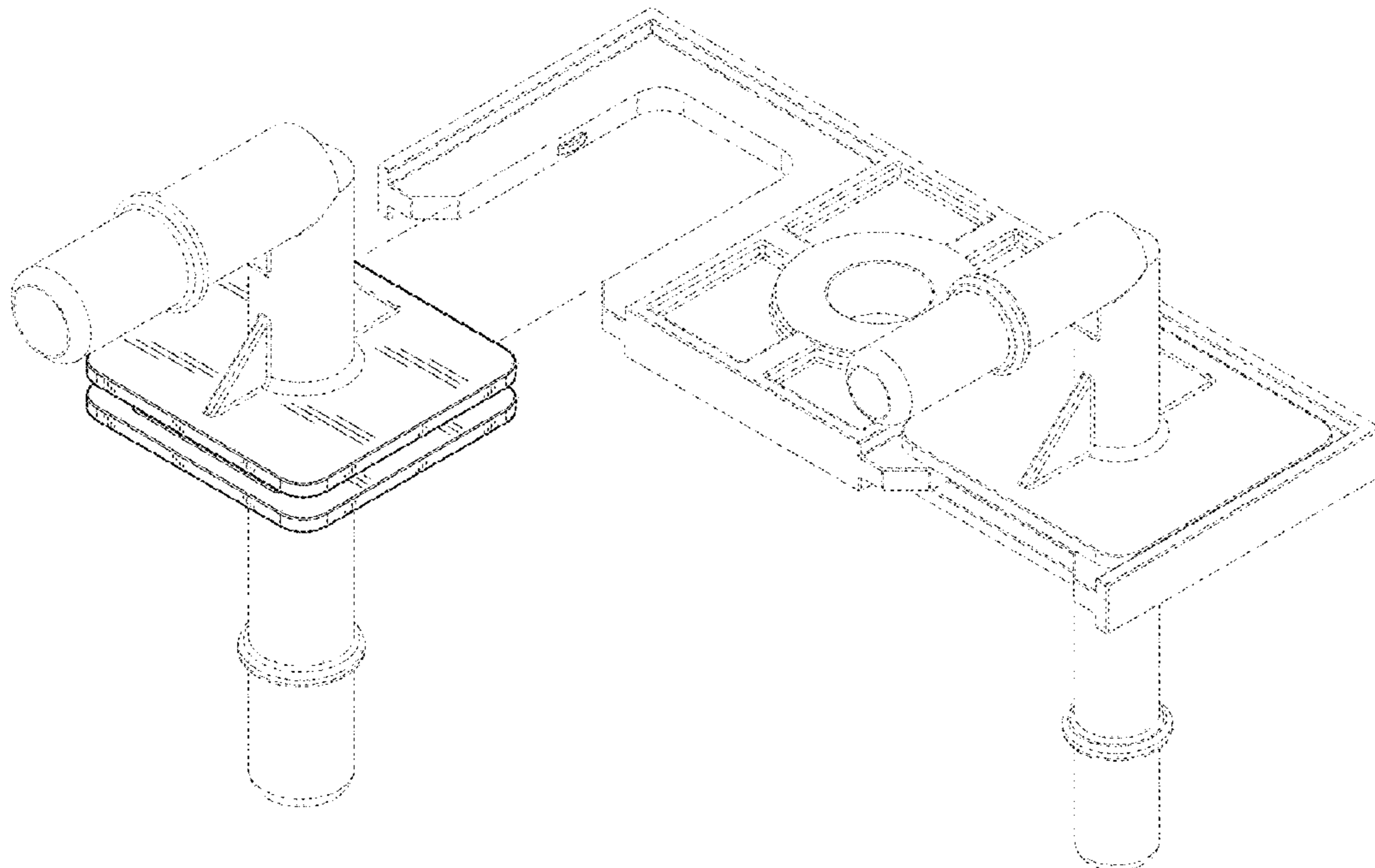
(57) **CLAIM**

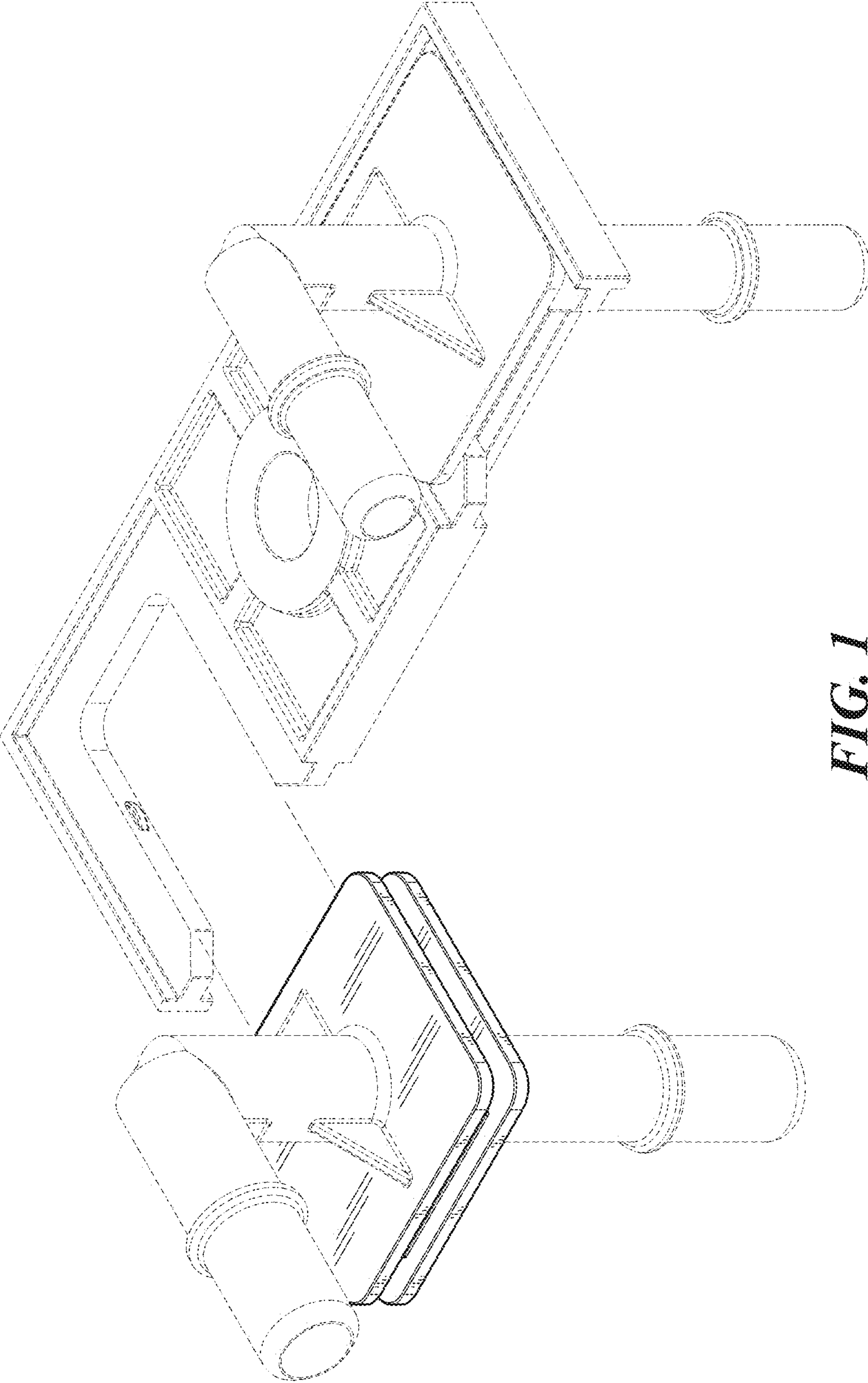
The ornamental design for a vehicle fluid line connector body, as shown and described.

FIG. 1 is a perspective view of a first embodiment of the vehicle fluid line connector body, the view depicting an example installation in which the article can be employed; FIG. 2 is another perspective view of the vehicle fluid line connector body shown in isolation; FIG. 3 is a front view thereof; FIG. 4 is a rear view thereof; FIG. 5 is a top view thereof; FIG. 6 is a bottom view thereof; FIG. 7 is a rightside view thereof; FIG. 8 is a leftside view thereof; FIG. 9 is a perspective view of a second embodiment of the vehicle fluid line connector body, the view depicting an example installation in which the article can be employed; FIG. 10 is a top view of the second embodiment; FIG. 11 is a bottom view of the second embodiment (the front, rear, rightside, and leftside views for the second embodiment are the same as those provided for the first embodiment with respect to the claimed design, and hence are not repeated here for the second embodiment); FIG. 12 is a perspective view of a third embodiment of the vehicle fluid line connector body, the view depicting an example installation in which the article can be employed; FIG. 13 is another perspective view of the third embodiment; and, FIG. 14 is a bottom view of the third embodiment (the front, rear, rightside, and leftside views for the third embodiment are the same as those provided for the first embodiment with respect to the claimed design, and hence are not repeated here for the third embodiment).

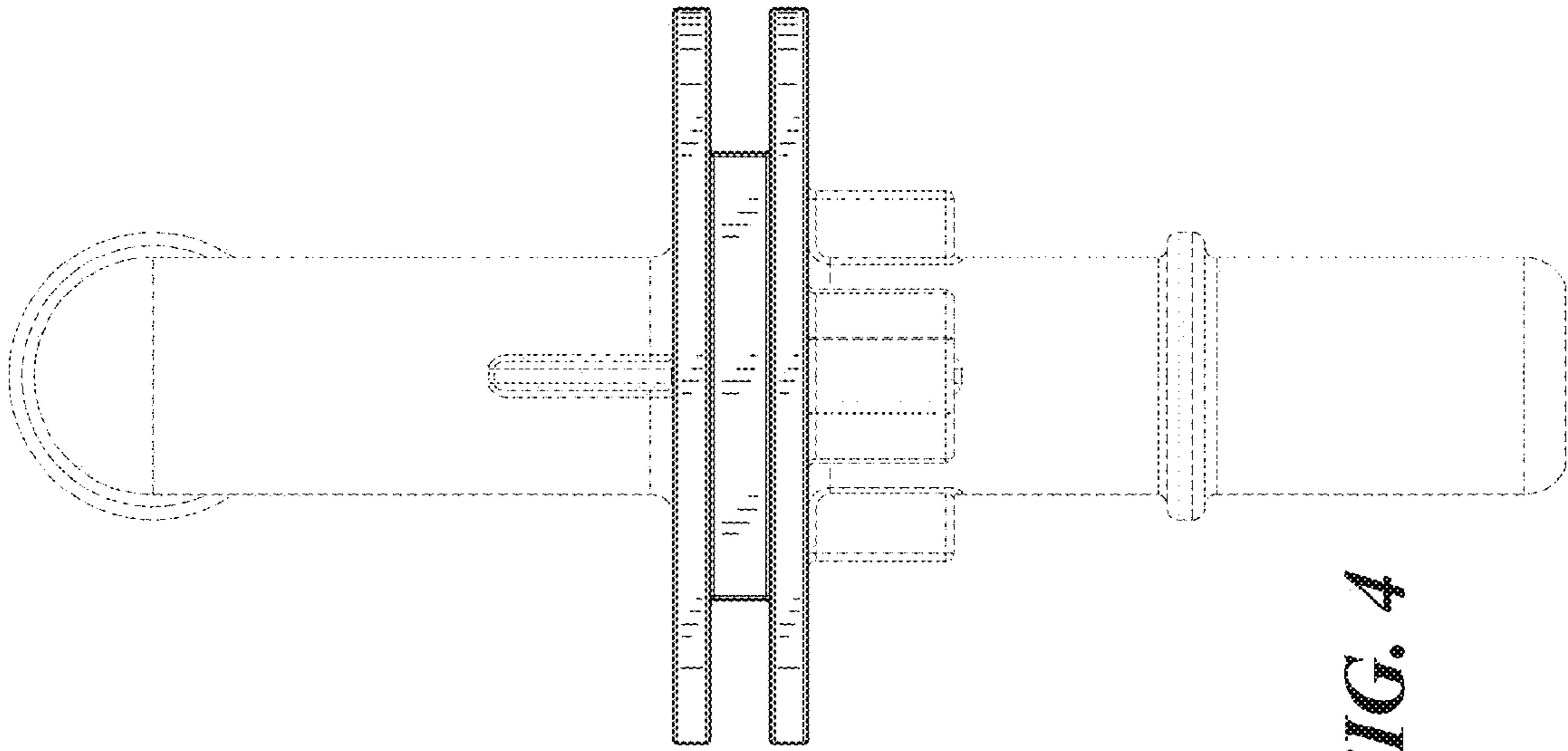
The broken lines in the drawings illustrate portions of the article that form no part of the claimed design.

**1 Claim, 8 Drawing Sheets**

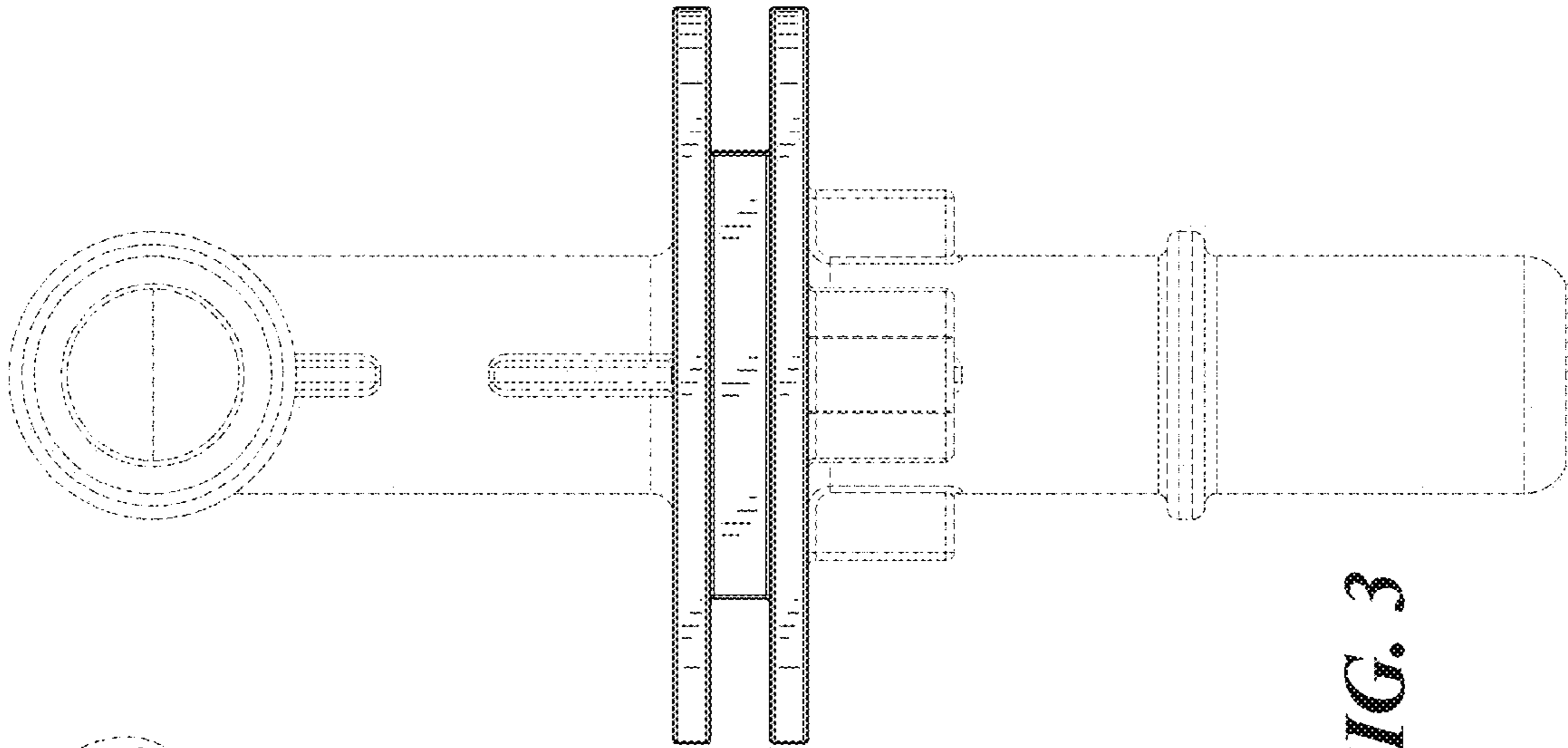




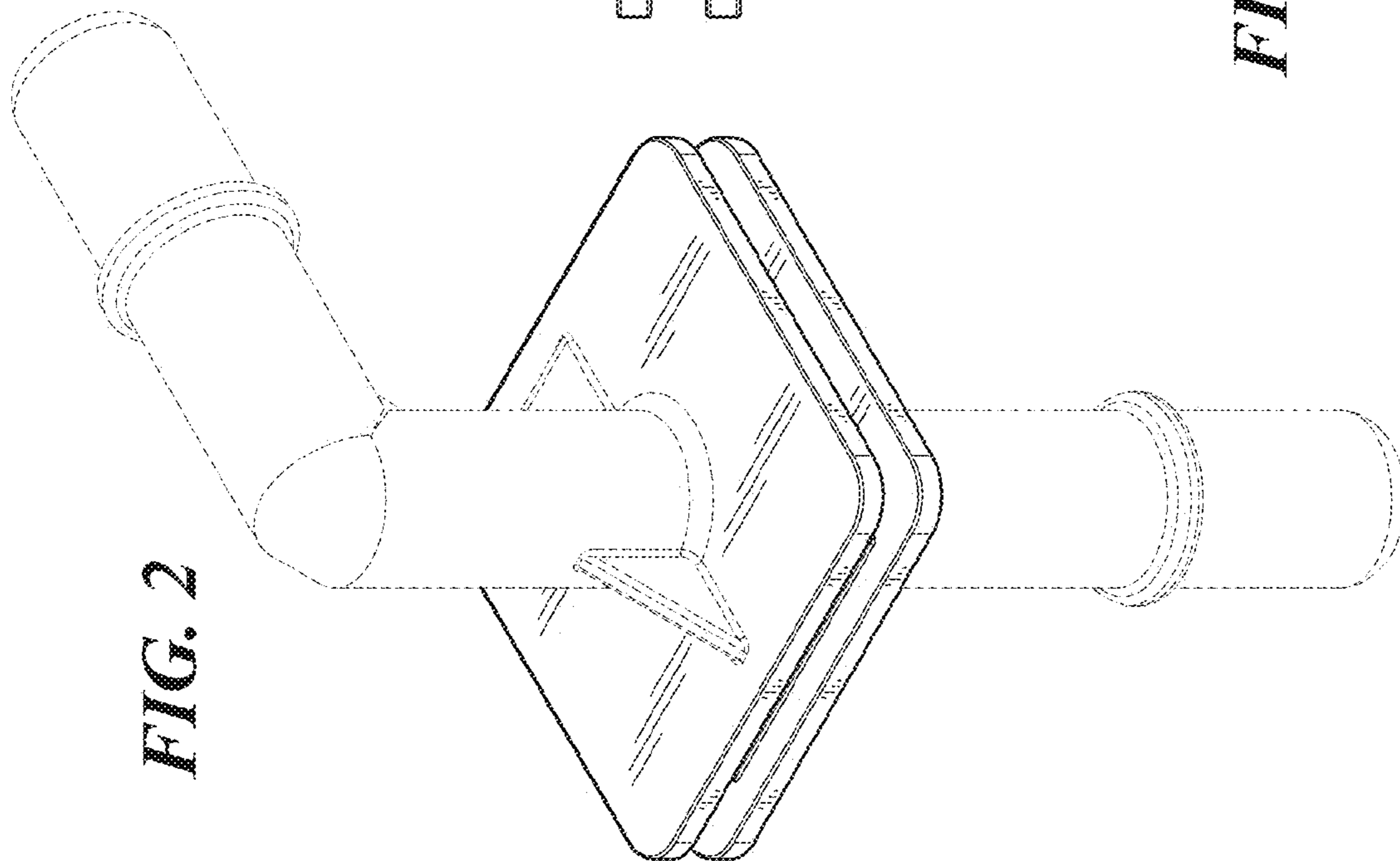
**FIG. 1**



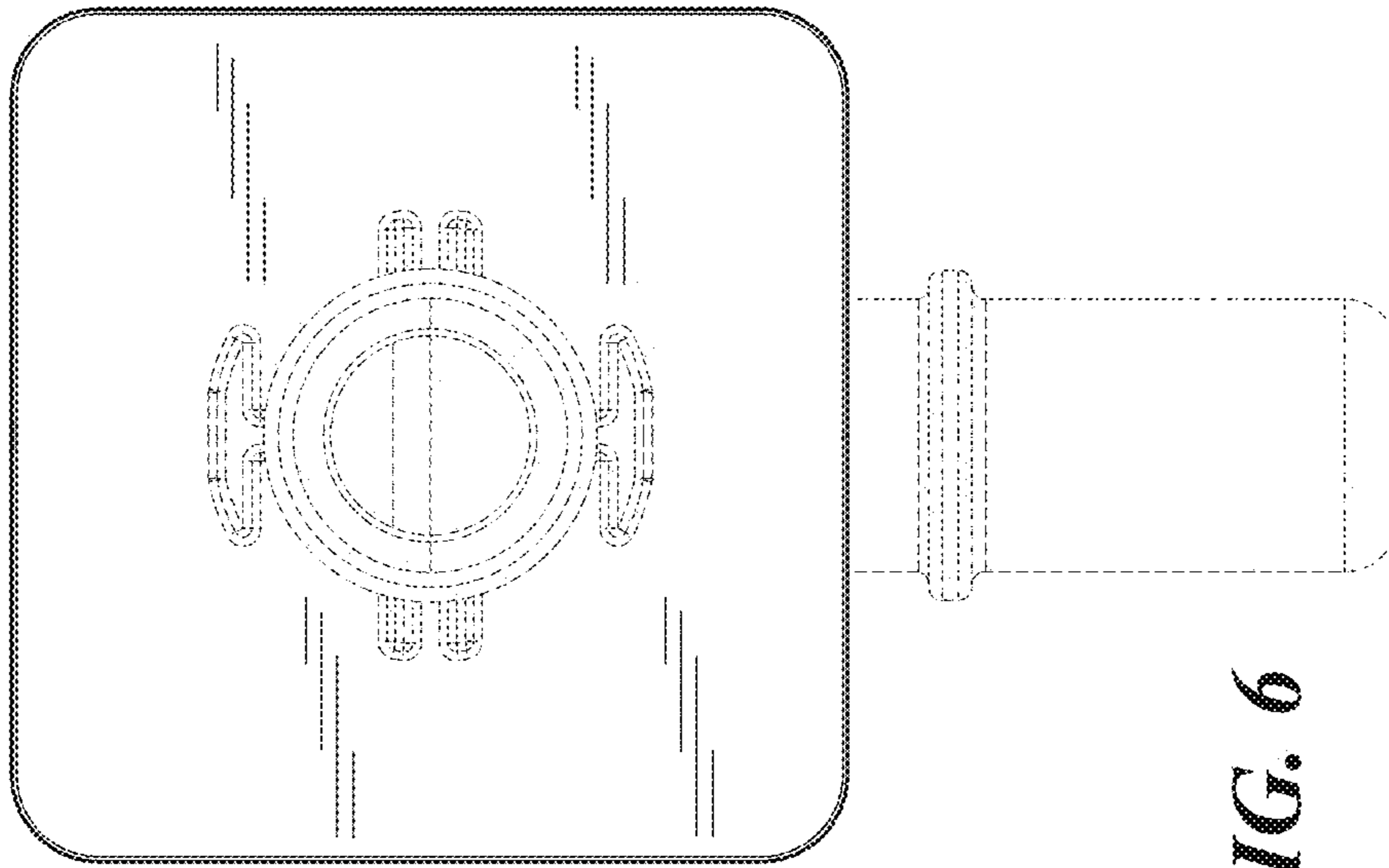
**FIG. 2**



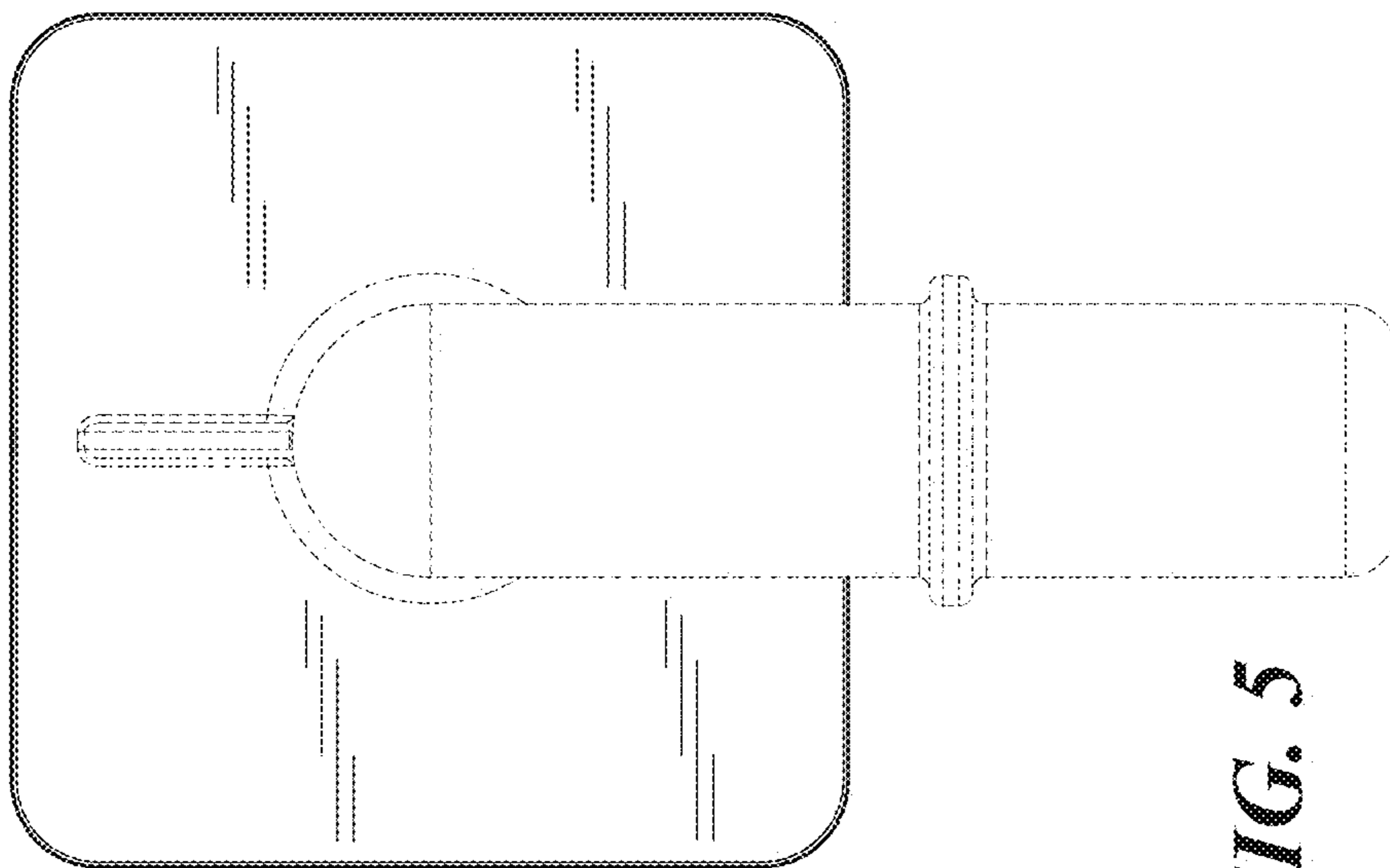
**FIG. 3**



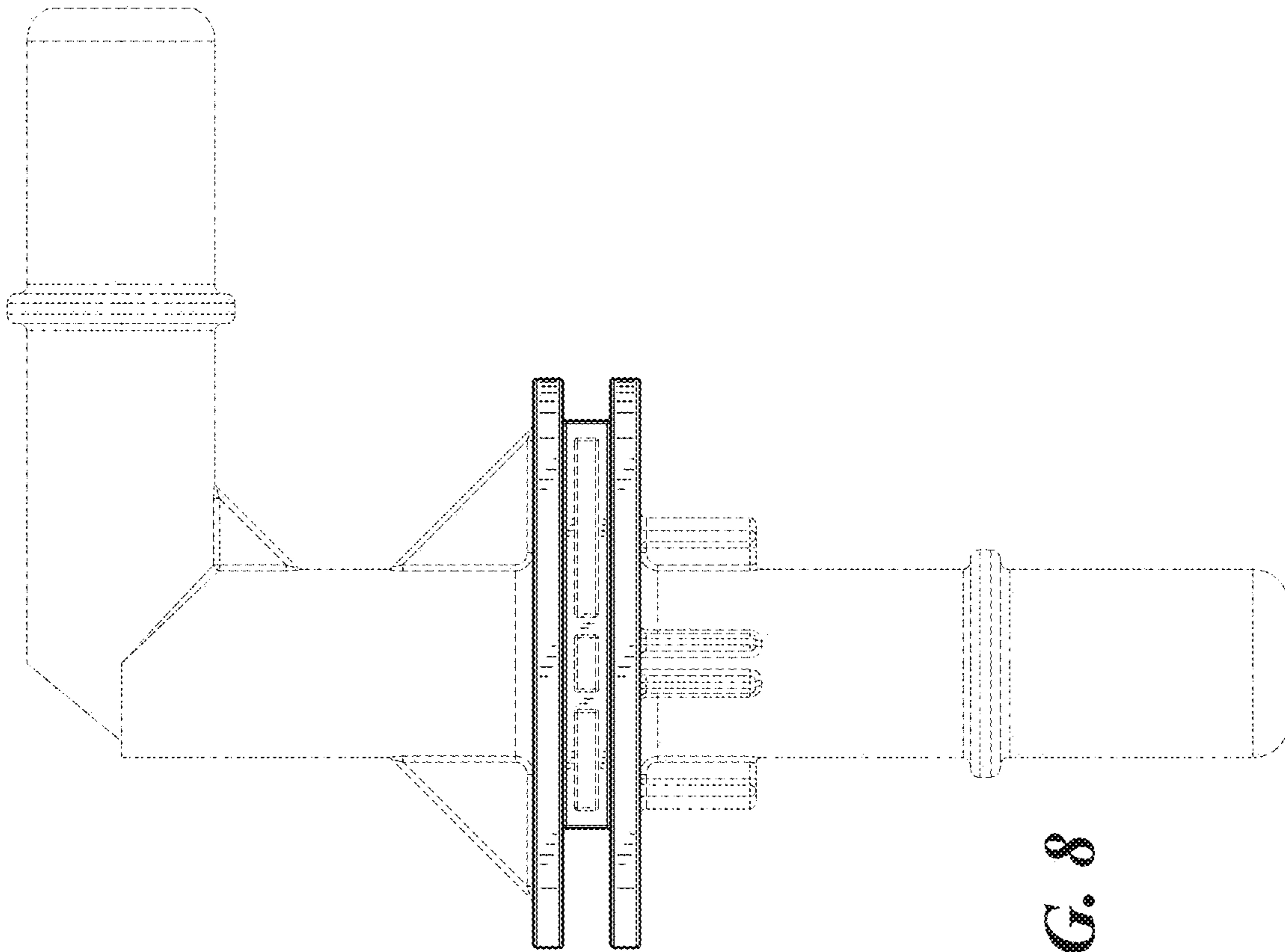
**FIG. 4**



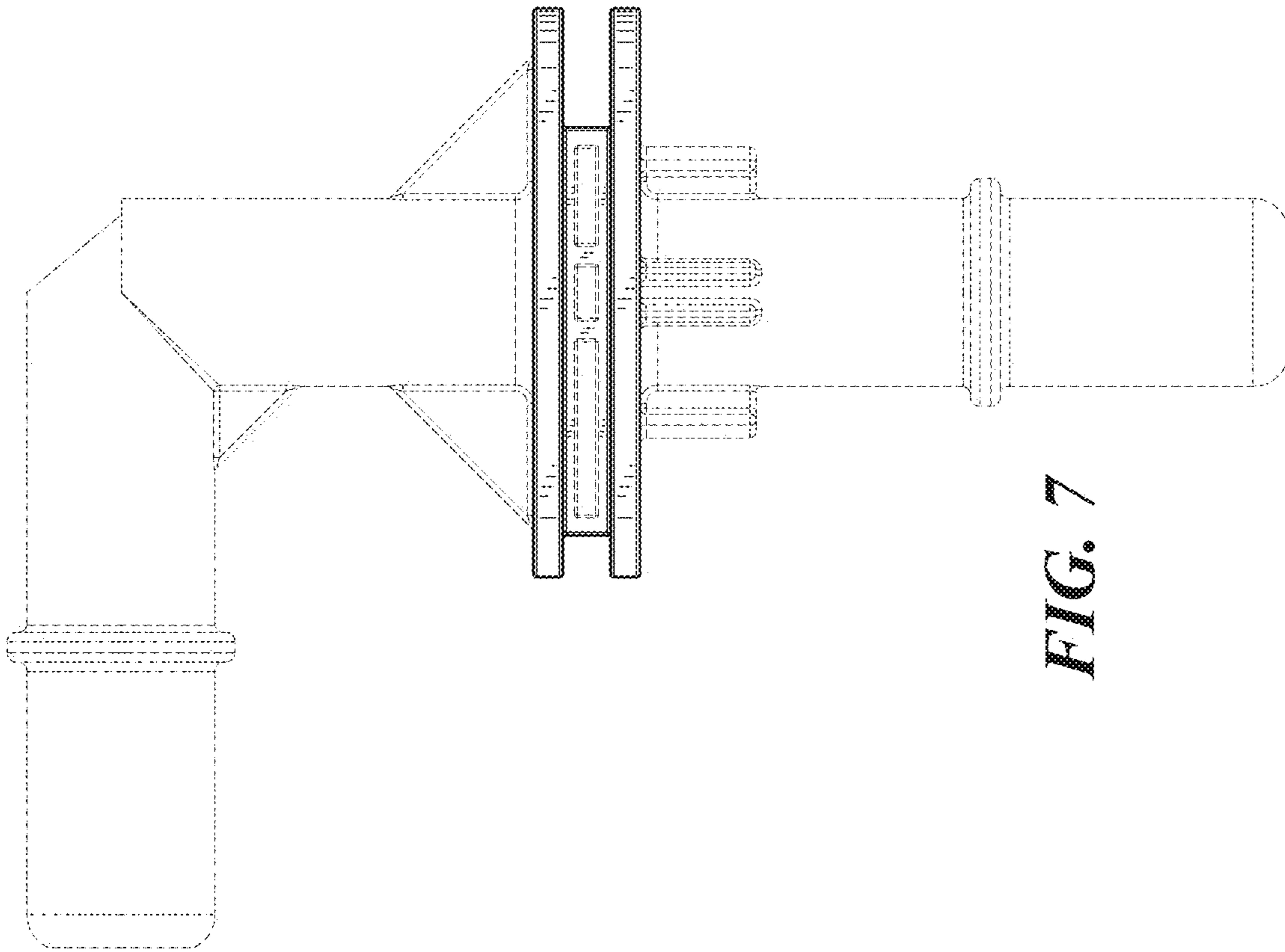
**FIG. 5**



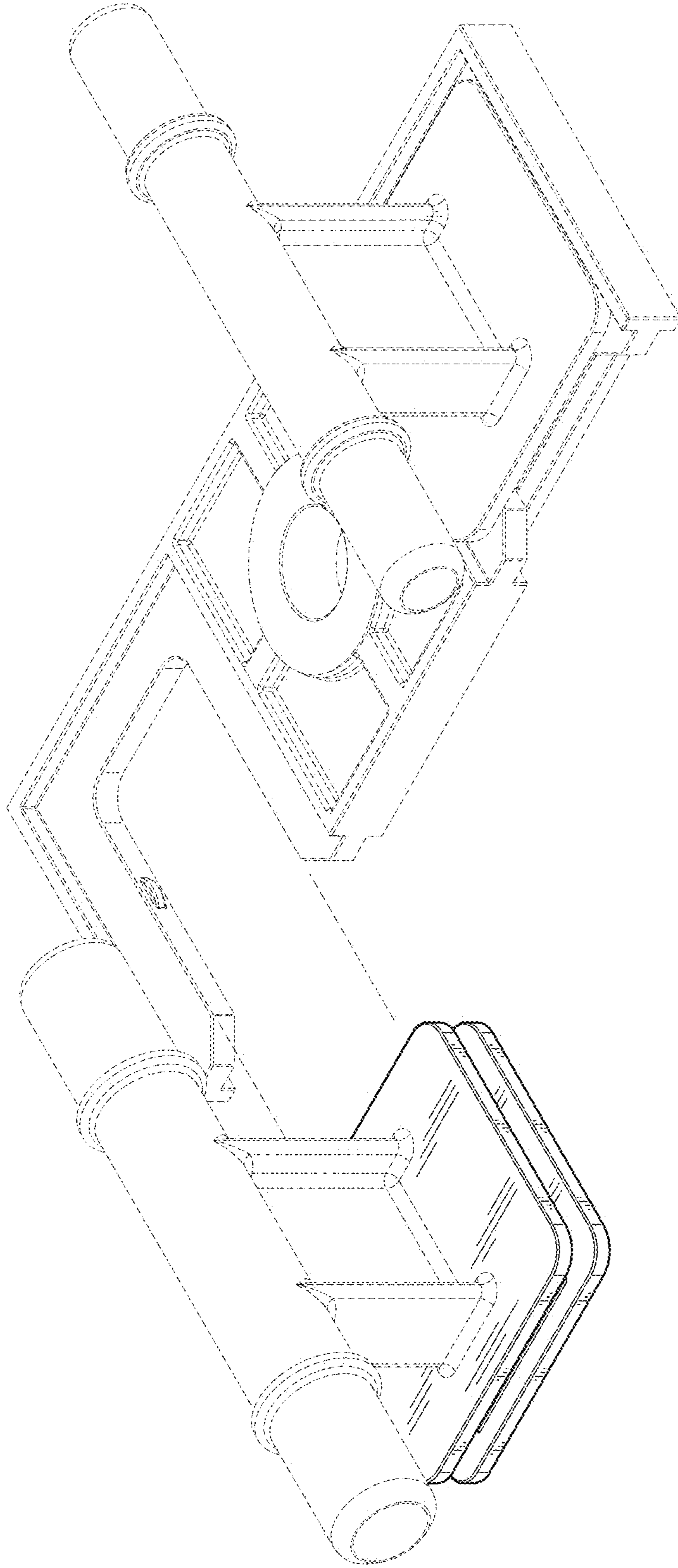
**FIG. 6**



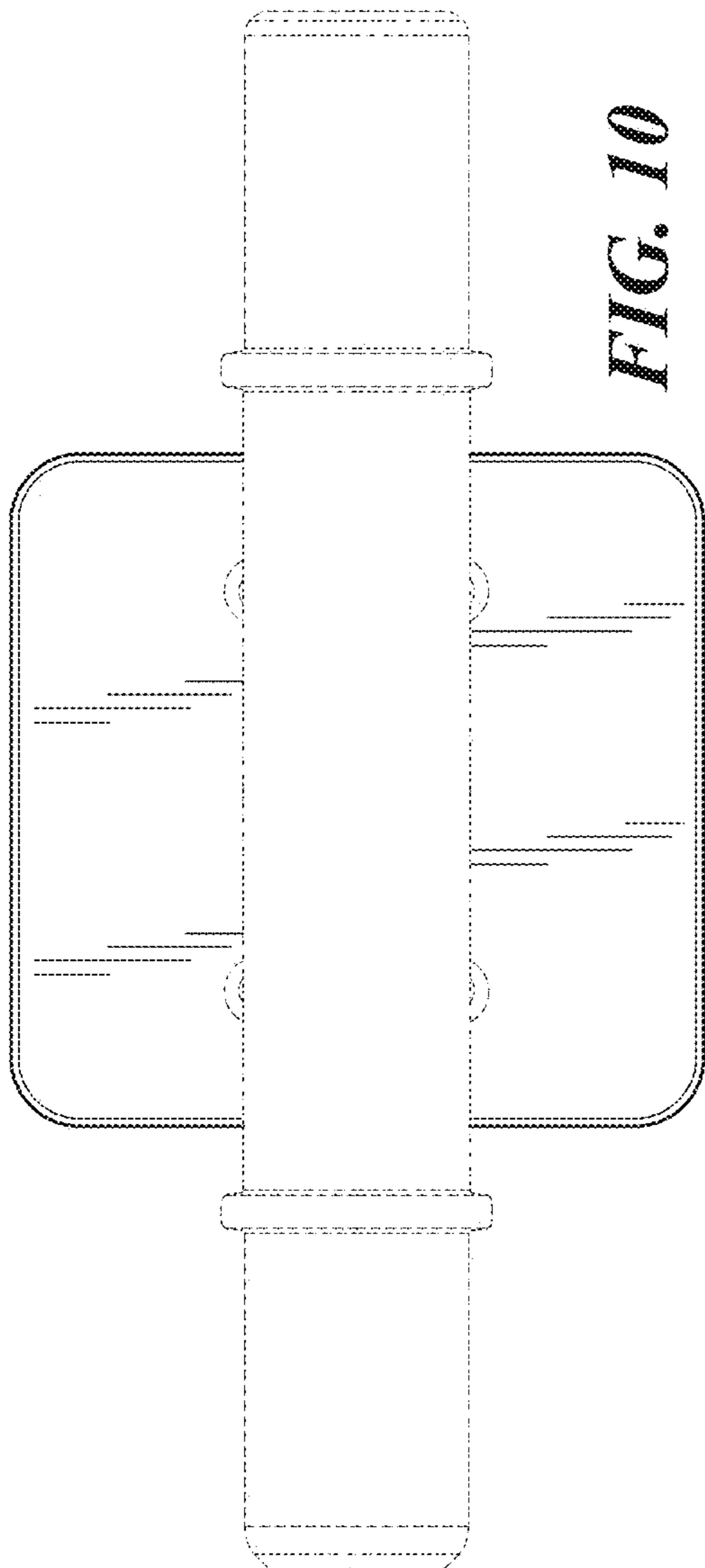
**FIG. 7**



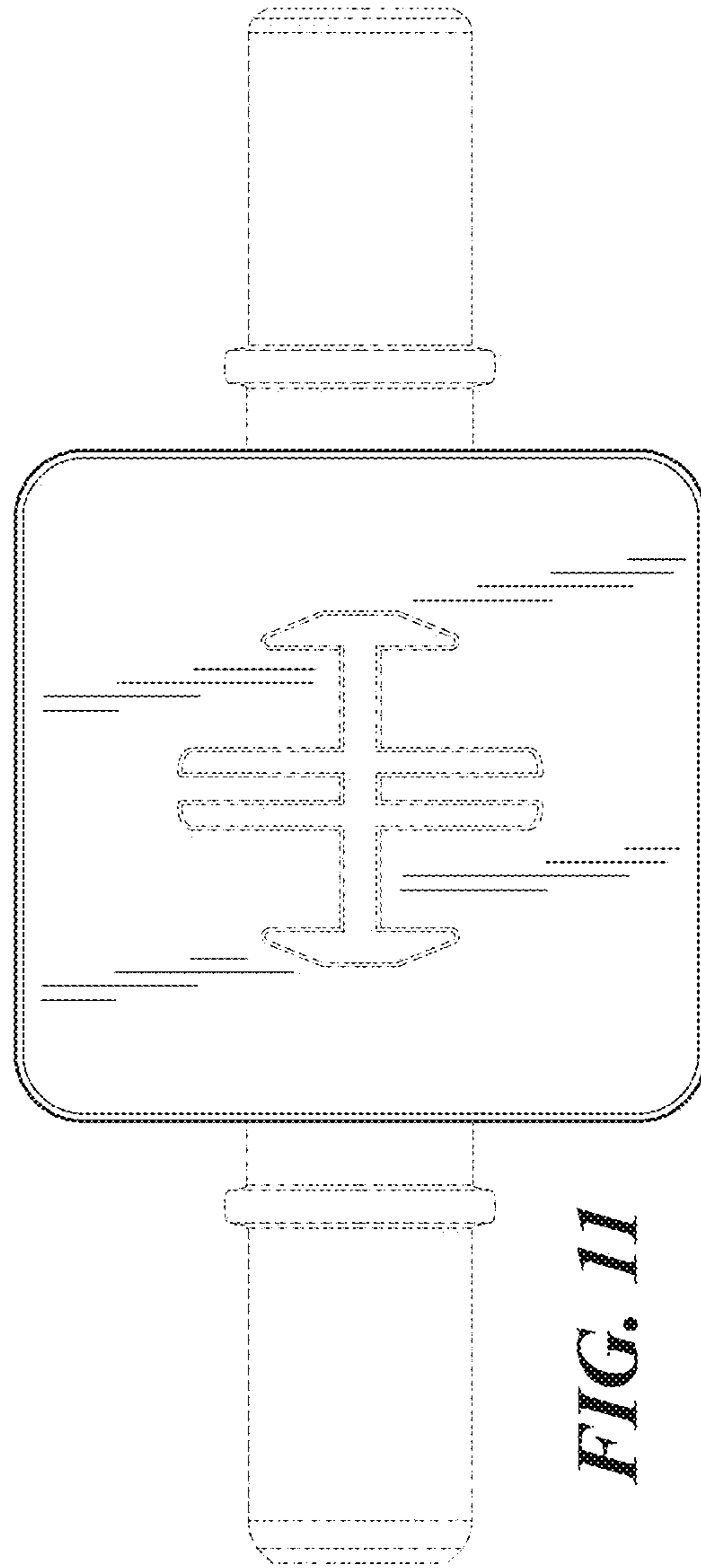
**FIG. 8**



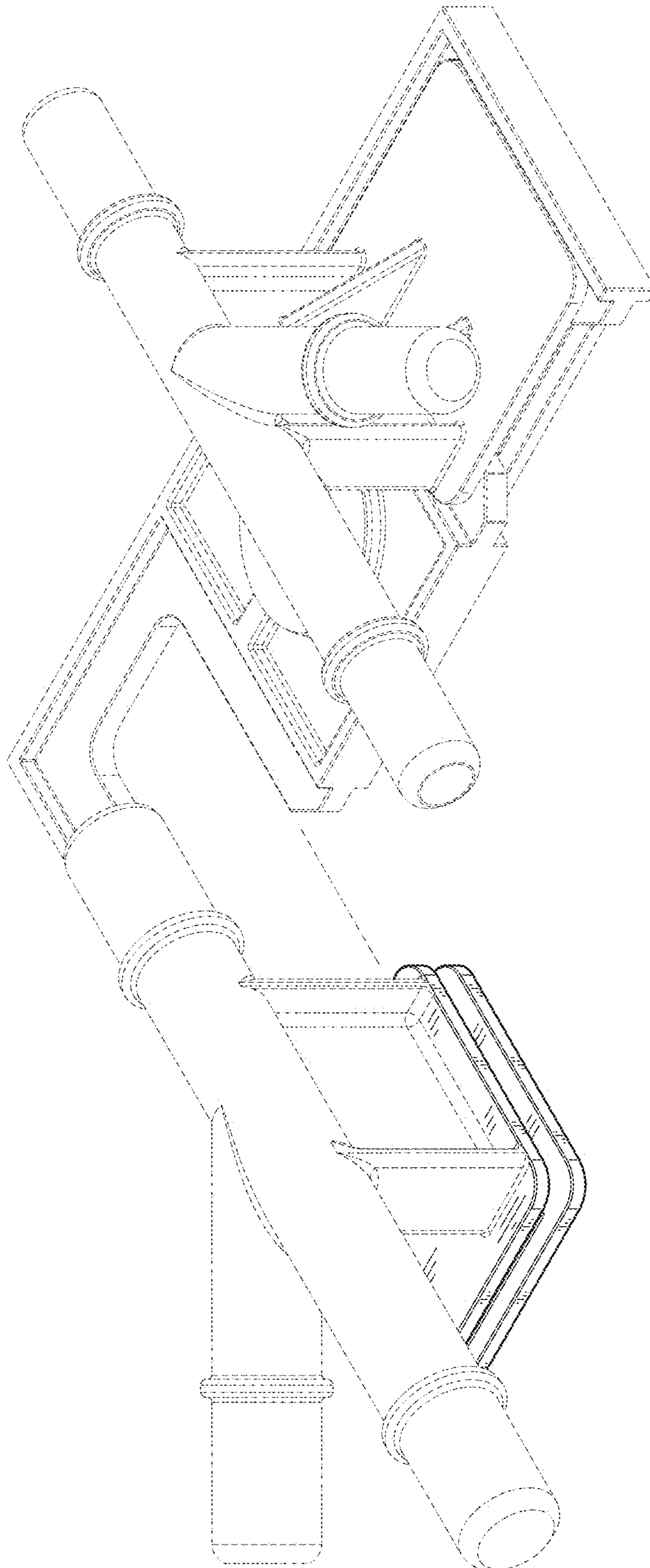
**FIG. 9**



**FIG. 10**

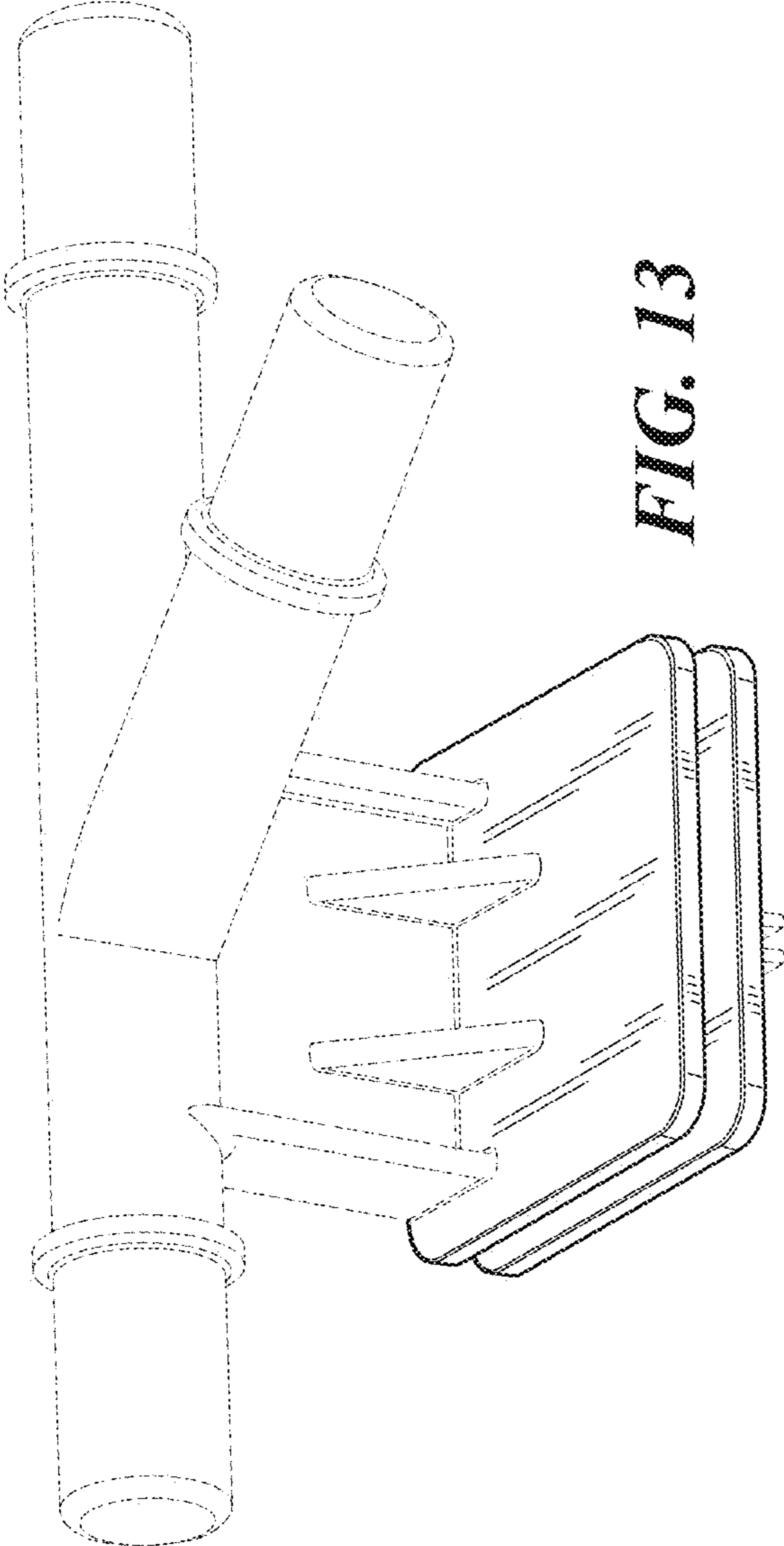


**FIG. 11**

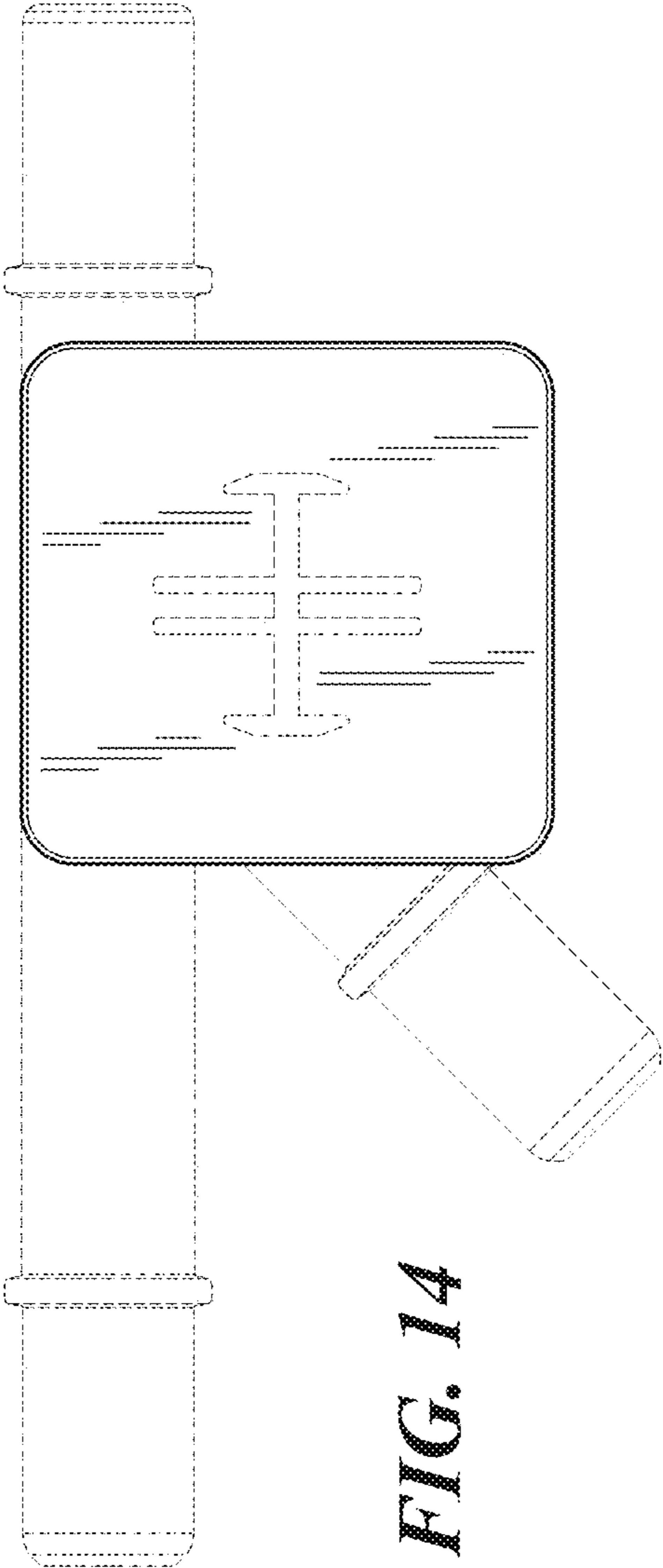


**FIG. 12**





**FIG. 13**



**FIG. 14**