



(12) **United States Design Patent**
Iijima

(10) **Patent No.:** **US D967,060 S**
(45) **Date of Patent:** **** Oct. 18, 2022**

(54) **SOUND EFFECTS BOARD**
(71) Applicant: **ZOOM CORPORATION**, Tokyo (JP)
(72) Inventor: **Masahiro Iijima**, Tokyo (JP)
(73) Assignee: **ZOOM CORPORATION**, Tokyo (JP)
(**) Term: **15 Years**

(21) Appl. No.: **29/719,023**
(22) Filed: **Dec. 31, 2019**

(30) **Foreign Application Priority Data**
Dec. 17, 2019 (JP) 2019-027956
(51) **LOC (13) Cl.** **14-01**
(52) **U.S. Cl.**
USPC **D14/217**
(58) **Field of Classification Search**
USPC D14/217, 257, 258, 434, 496, 162, 167,
D14/175, 188, 196, 197, 198
(Continued)

(56) **References Cited**
U.S. PATENT DOCUMENTS
D455,731 S * 4/2002 Mackie D14/217
D493,783 S * 8/2004 Pietras D14/257
(Continued)

FOREIGN PATENT DOCUMENTS
CN 302889256 * 7/2014
CN 304904151 * 11/2018
(Continued)

OTHER PUBLICATIONS
The Zoom G11, announced © 2021 [online], retrieved Sep. 24,
2021, retrieved from internet, <https://zoomcorp.com/en/jp/multi-effects/guitar-effects/g11/>.
(Continued)

Primary Examiner — Messina L Smith
(74) *Attorney, Agent, or Firm* — The Webb Law Firm

(57) **CLAIM**
The ornamental design for a sound effects board, as shown and described.

DESCRIPTION
FIG. 1 is a top view of a sound effects board, showing my new design;
FIG. 2 is a bottom view thereof;
FIG. 3 is a front elevational view thereof;
FIG. 4 is a rear elevational view thereof;
FIG. 5 is a right side elevational view thereof;
FIG. 6 is a left side elevational view thereof;
FIG. 7 is a top view thereof showing a first display state of the sound effects board;
FIG. 8 is a top view thereof showing a second display state of the sound effects board;
FIG. 9 is an enlarged perspective view of the knob of the sound effects board in FIG. 1, shown separately to illustrate aspects of the design that are not visible when combined;
FIG. 10 is an enlarged top plan view of the knob of the sound effects board, shown separately to illustrate aspects of the design that are not visible when combined, shown in an alternate configuration;
FIG. 11 is an enlarged top plan view of the knob of the sound effects board, shown by a first alternative configuration;
FIG. 12 is an enlarged top plan view of the knob of the sound effects board, shown by a second alternative configuration;
FIG. 13 is an enlarged top plan view of the knob of the sound effects board, shown by a third alternative configuration;
FIG. 14 is an enlarged top plan view of the knob of the sound effects board, shown by a fourth alternative configuration;
FIG. 15 is an enlarged top plan view of the knob of the sound effects board, shown by a fifth alternative configuration;
FIG. 16 is an enlarged top plan view of the knob of the sound effects board, shown by a sixth alternative configuration;
FIG. 17 is an enlarged top plan view of the knob of the sound effects board, shown by a seventh alternative configuration;
FIG. 18 is an enlarged top plan view of the knob of the sound effects board, shown by an eighth alternative configuration;

(Continued)

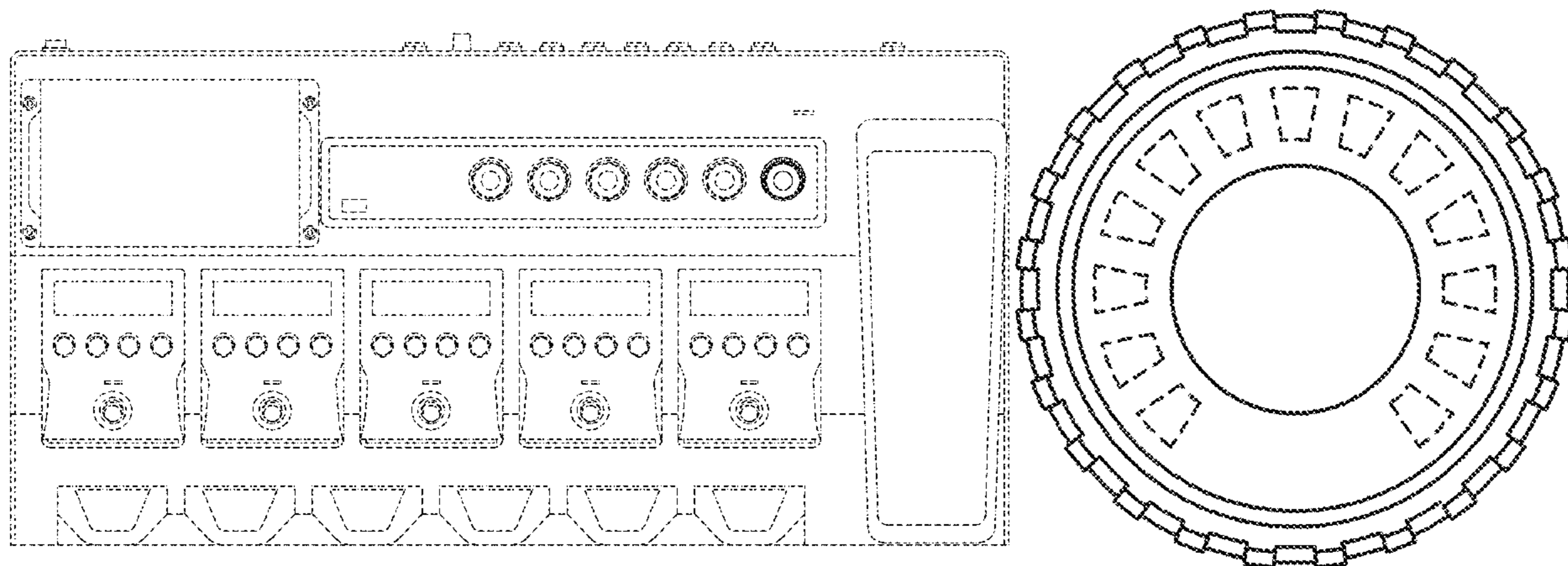

FIG. 19 is an enlarged top plan view of the knob of the sound effects board, shown by a ninth alternative configuration; FIG. 20 is an enlarged top plan view of the knob of the sound effects board, shown by a tenth alternative configuration; FIG. 21 is an enlarged top plan view of the knob of the sound effects board, shown by an eleventh alternative configuration; FIG. 22 is an enlarged top plan view of the knob of the sound effects board, shown by a twelfth alternative configuration; FIG. 23 is an enlarged top plan view of the knob of the sound effects board, shown by a thirteenth alternative configuration; FIG. 24 is an enlarged top plan view of the knob of the sound effects board, shown by a fourteenth alternative configuration; FIG. 25 is an enlarged top plan view of the knob of the sound effects board, shown by a fifteenth alternative configuration; FIG. 26 is an enlarged top plan view of the knob of the sound effects board, shown by a sixteenth alternative configuration; FIG. 27 is an enlarged top plan view of the knob of the sound effects board, shown by a seventeenth alternative configuration; FIG. 28 is an enlarged top plan view of the knob of the sound effects board, shown by an eighteenth alternative configuration; FIG. 29 is an enlarged top plan view of the knob of the sound effects board, shown by a nineteenth alternative configuration; FIG. 30 is an enlarged top plan view of the knob of the sound effects board, shown by a twentieth alternative configuration; FIG. 31 is an enlarged top plan view of the knob of the sound effects board, shown by a twenty-first alternative configuration; FIG. 32 is an enlarged top plan view of the knob of the sound effects board, shown by a twenty-second alternative configuration; FIG. 33 is an enlarged top plan view of the knob of the sound effects board, shown by a twenty-third alternative configuration; FIG. 34 is an enlarged top plan view of the knob of the sound effects board, shown by a twenty-fourth alternative configuration; and, FIG. 35 is an enlarged top plan view of the knob of the sound effects board, shown by a twenty-fifth alternative configuration.

The portions of the sound effects board shown in broken lines form no part of the claimed design.

1 Claim, 35 Drawing Sheets

(58) **Field of Classification Search**

CPC G10H 1/0066; G10H 1/0008; G10H 1/32; G10H 1/38; G10H 1/0091; G10H 1/34; G10H 1/348; G10H 1/02; G10H 1/46; G10H 1/0025; G10H 1/0058; G10H 1/00; G10H 1/28; G10H 1/342; G10H 1/36; G10H 1/383; G10H 1/0033; G10H 1/0083; G10H 1/0575; G10H 1/06; G10H

1/18; G10H 1/386; G10H 2220/106; G10H 2220/096; G10H 2220/201; G10H 2220/241; G10H 2220/101; G10H 2230/015; G10H 2230/021; G10H 2210/125; G10H 2210/006; G10H 2210/081; G10H 2210/095; G10H 2240/211; G10H 7/008; G10H 7/02; G10H 7/00; G10H 3/146; G10H 3/188

See application file for complete search history.

(56)

References Cited

U.S. PATENT DOCUMENTS

D555,637	S	*	11/2007	Ishizaki	D14/217
D772,200	S	*	11/2016	Tschetter	D14/217
D807,860	S	*	1/2018	Tschetter	D14/217
D815,064	S	*	4/2018	Garncarz	D14/217
D827,611	S	*	9/2018	Kuramoto	D14/217
D881,268	S	*	4/2020	Kuramoto	D17/99
D890,252	S	*	7/2020	Iori	D17/99
D890,722	S	*	7/2020	Wrigley	D14/217
D895,574	S	*	9/2020	Schillebeeckx	D14/217
D902,178	S	*	11/2020	Tschetter	D14/217
D918,175	S	*	5/2021	Cantero Pendas	D14/217
D922,354	S	*	6/2021	Gill	D14/217
2003/0019733	A1	*	1/2003	Sato	H01H 9/181 200/310
2004/0109573	A1	*	6/2004	Haba	G10H 1/32 381/119
2005/0195997	A1	*	9/2005	Yang	H04R 3/00 381/119
2005/0259532	A1	*	11/2005	Roman	G11B 27/105 369/47.1
2006/0060071	A1	*	3/2006	Kato	H04H 60/04 84/645
2015/0062858	A1	*	3/2015	Kemp	H04H 60/04 361/826
2015/0078584	A1	*	3/2015	Moon	H03G 3/02 381/104
2019/0122648	A1	*	4/2019	Garncarz	G10H 1/0066
2020/0126525	A1	*	4/2020	Gill	G10H 1/0066
2020/0335075	A1	*	10/2020	Takagi	G10H 1/0083
2021/0225342	A1	*	7/2021	Thomas	G10H 1/0008

FOREIGN PATENT DOCUMENTS

CN	306831749	*	9/2021
JP	D1683302	*	3/2021
KR	300927919.0000	*	10/2017

OTHER PUBLICATIONS

Zoom G11 Multi-Effects Processor: Creating A Custom Patch, announced Mar. 1, 2021 [online], retrieved Sep. 24, 2021, retrieved from internet, <https://www.youtube.com/watch?v=Olgf8PkakNo>.*

Zoom G11 review, announced Nov. 26, 2020 [online], retrieved Sep. 24, 2021, retrieved from internet, <https://www.guitarworld.com/reviews/zoom-g11-review>.*

Zoom G11 Guitar Multi-Effects Processor with Expression Pedal, announced Apr. 21, 2020 [online], retrieved Sep. 24, 2021, retrieved from internet, <https://www.amazon.com/Zoom-Multi-Effects-Processor-Expression-Touchscreen/dp/B087D6R51M>.*

Zoom G5n Multi-Effects Guitar Processor, announced Mar. 18, 2016 [online], retrieved Sep. 24, 2021, retrieved from internet, <https://www.amazon.in/Zoom-G5n-Multi-Effects-Guitar-Processor/dp/B01AZ9PANW>.*

* cited by examiner

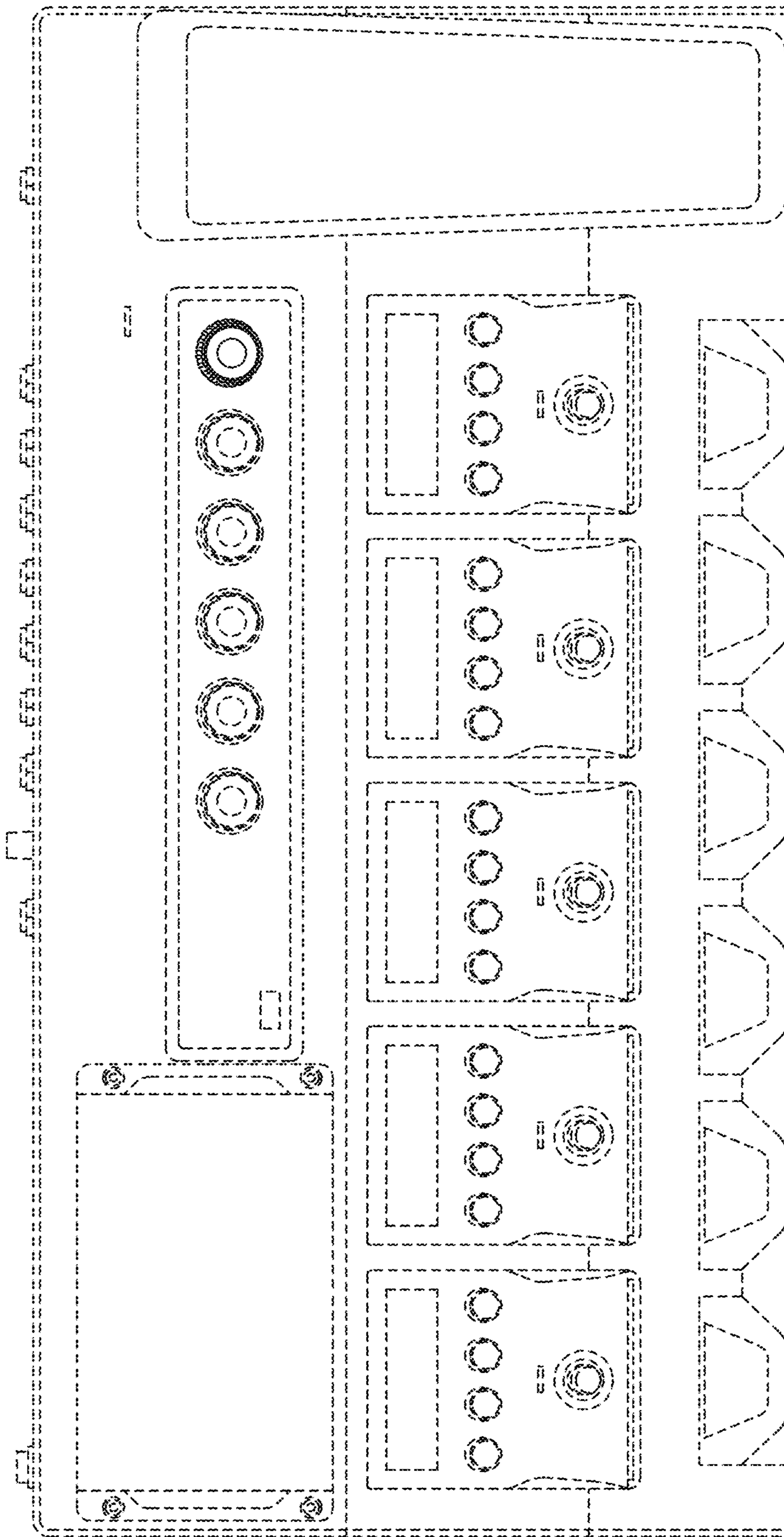

FIG. 1

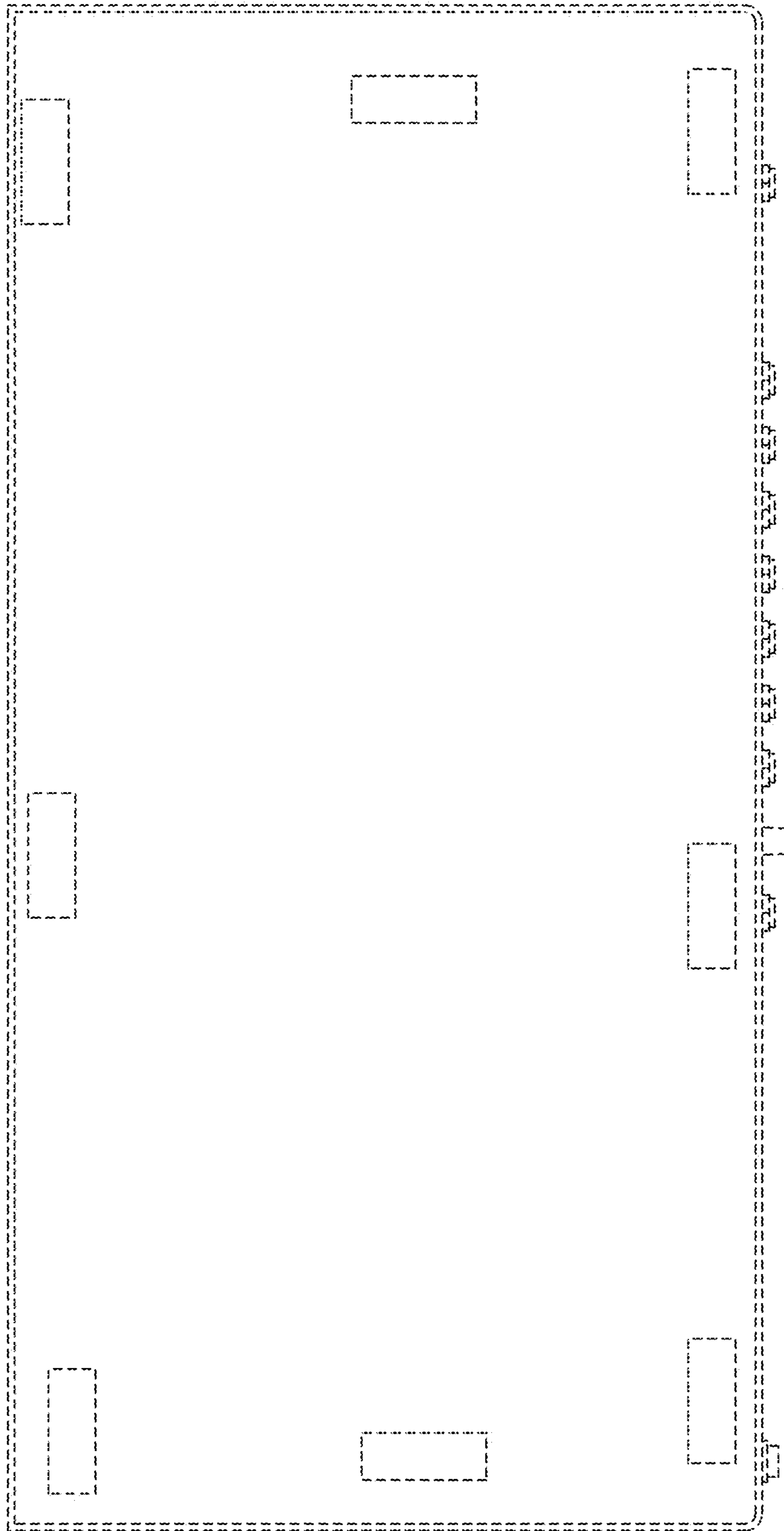

FIG. 2

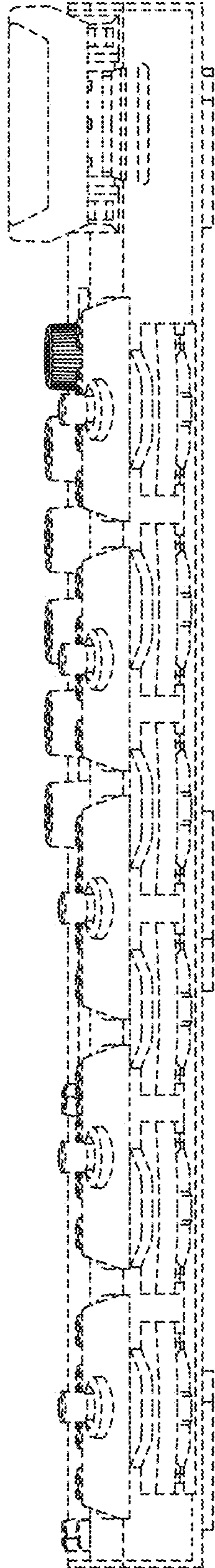

FIG. 3

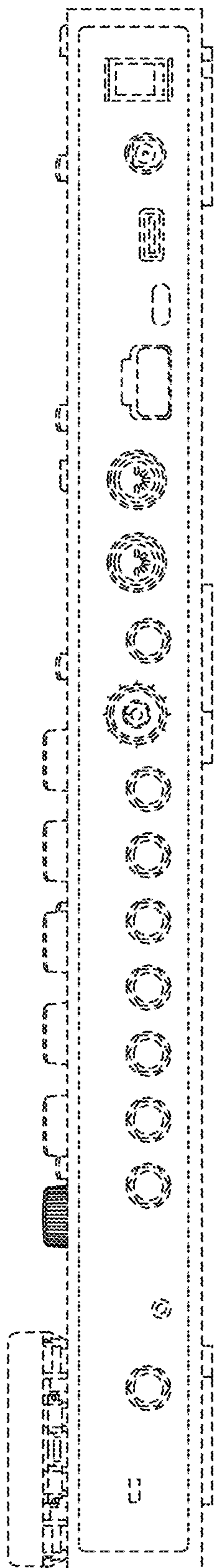

FIG. 4

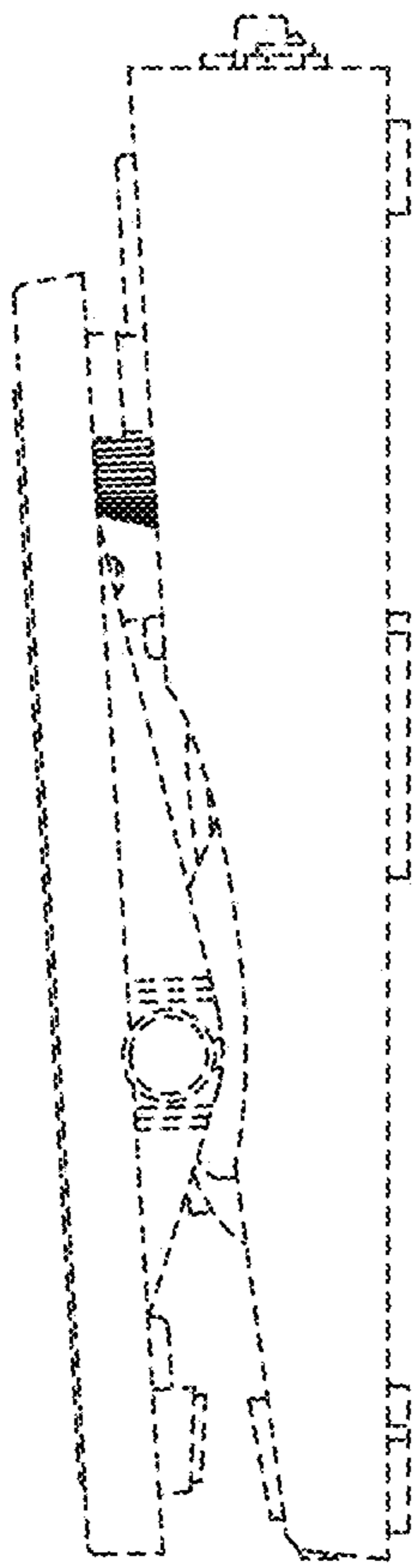

FIG. 5

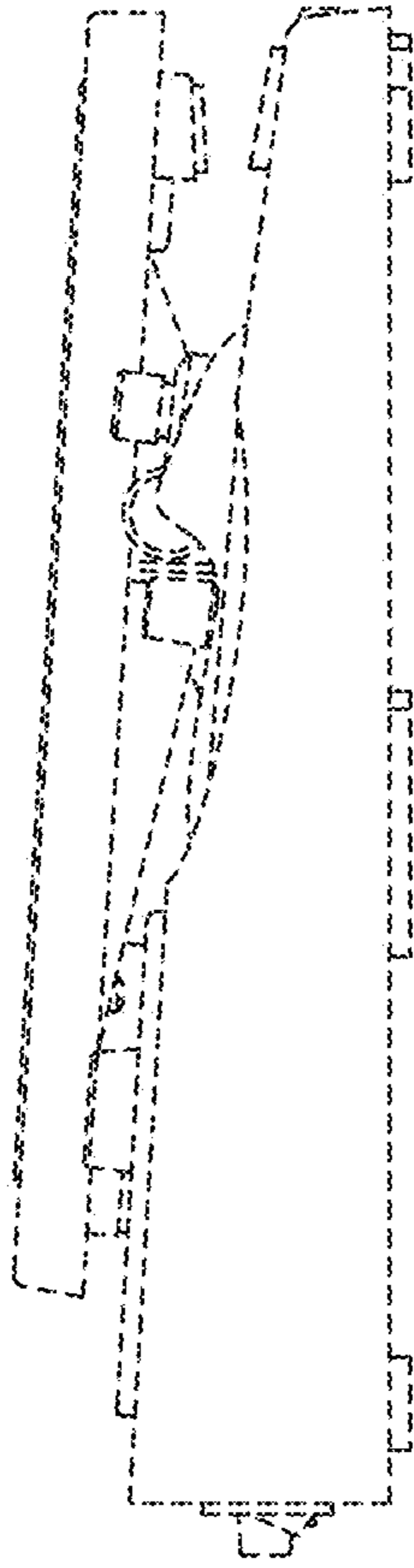

FIG. 6

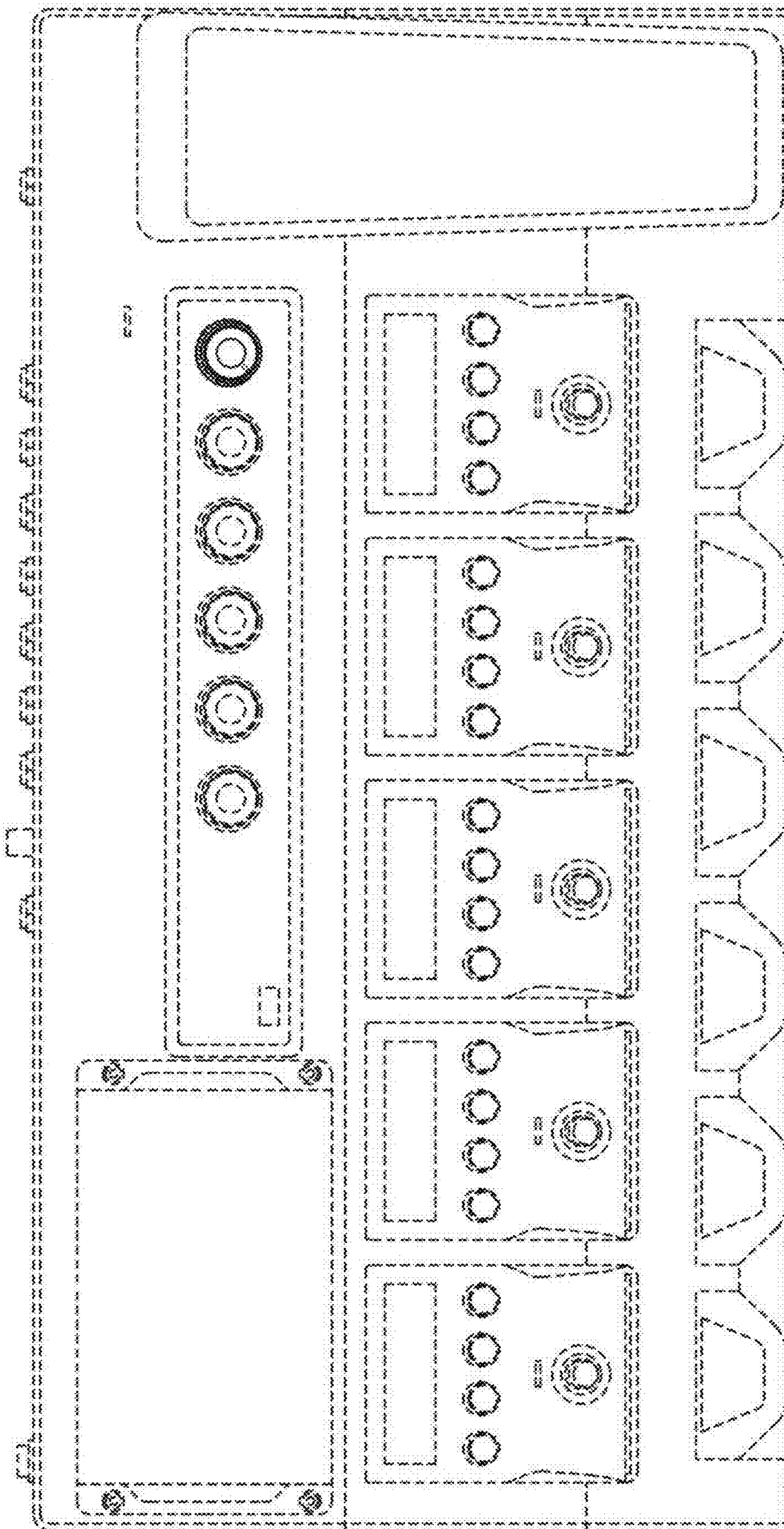

FIG. 7

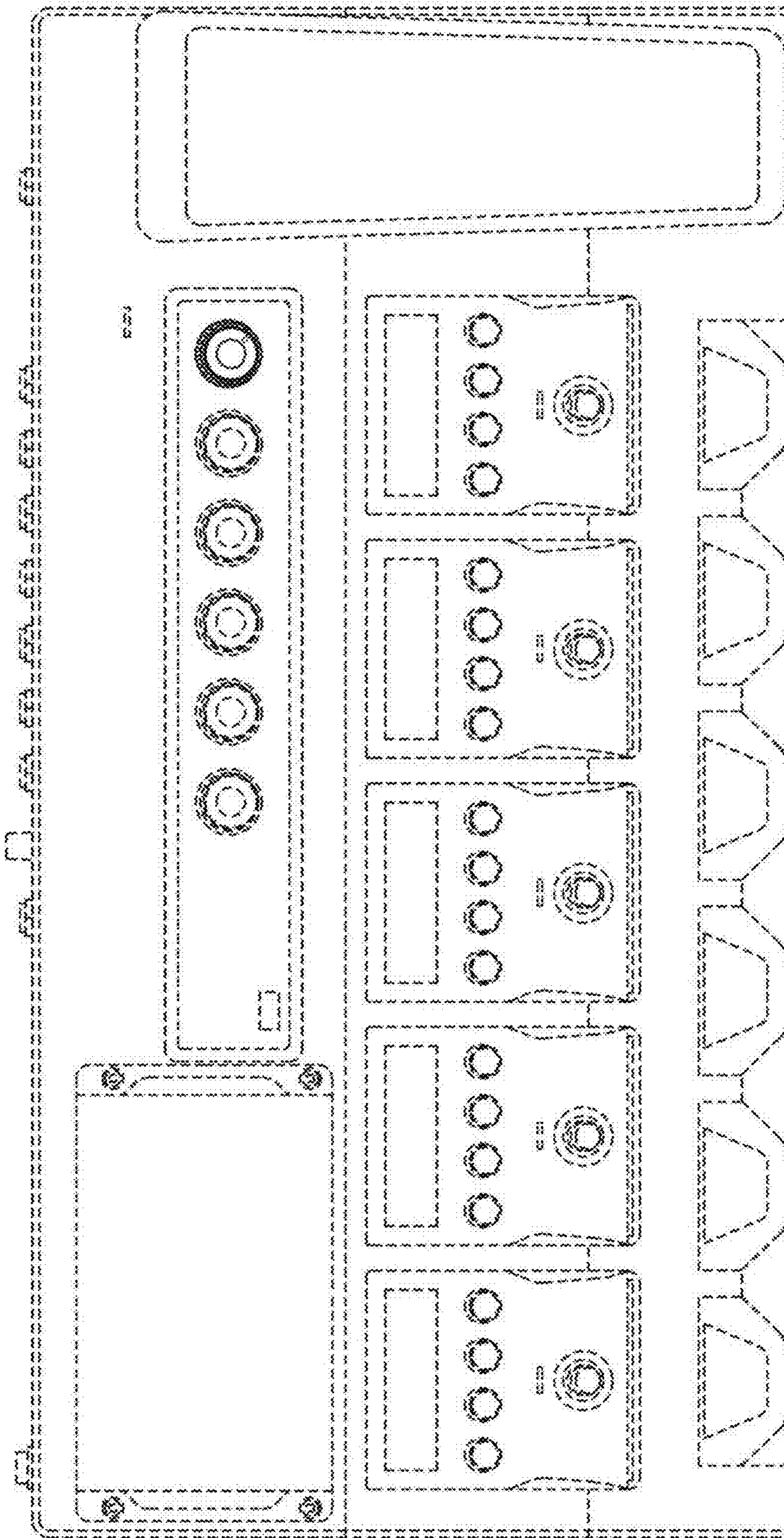

FIG. 8

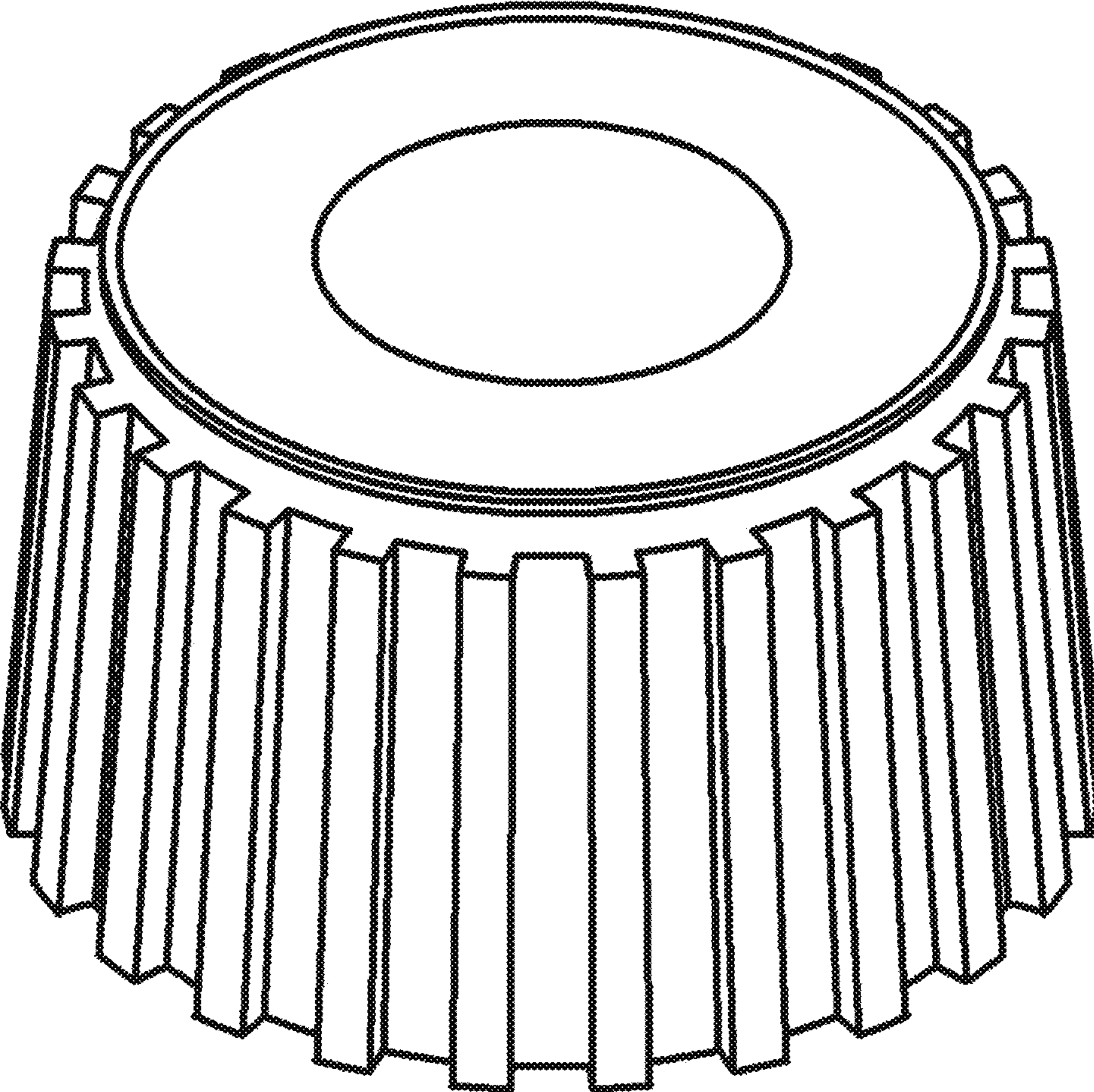

FIG. 9

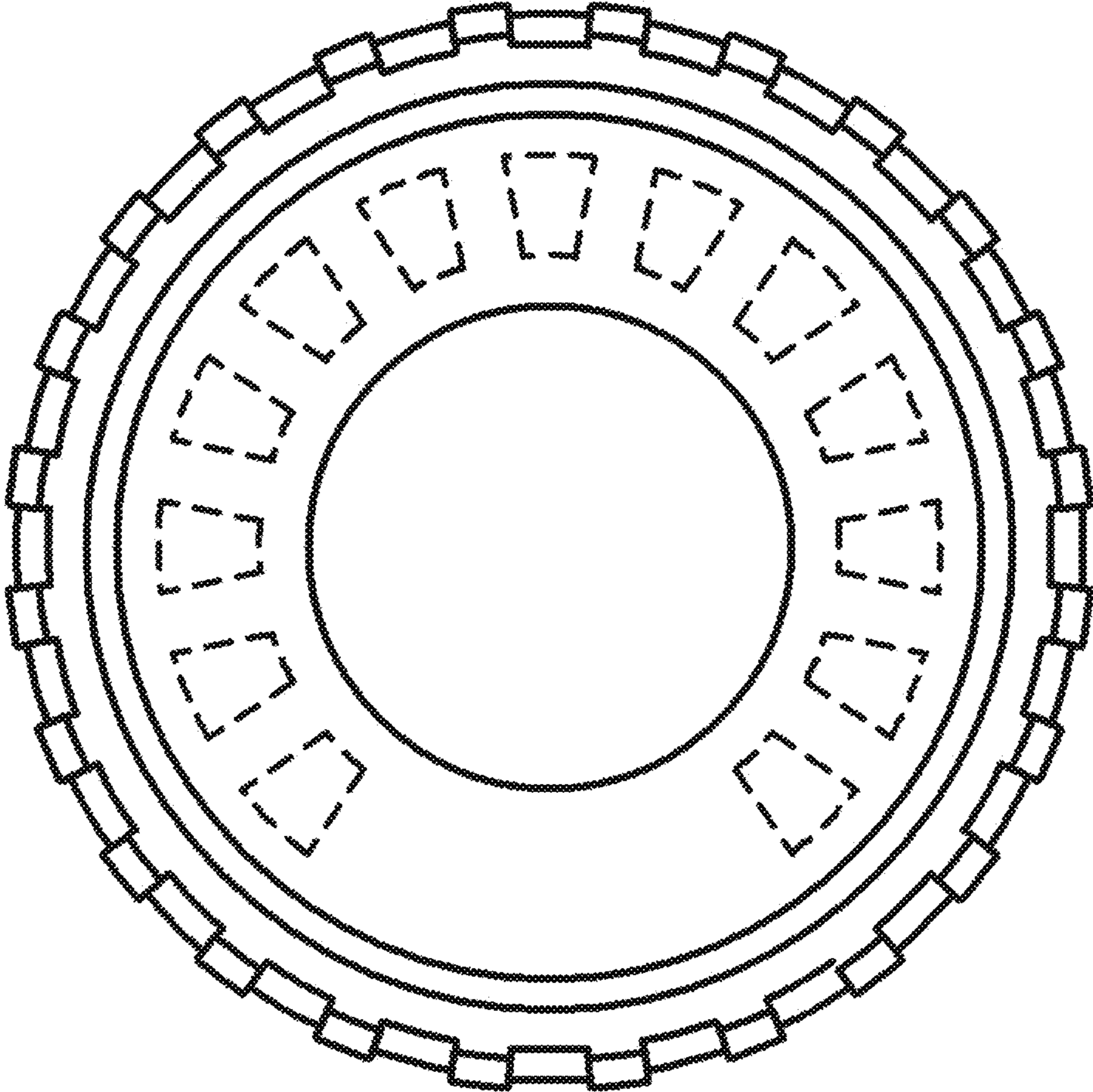

FIG. 10

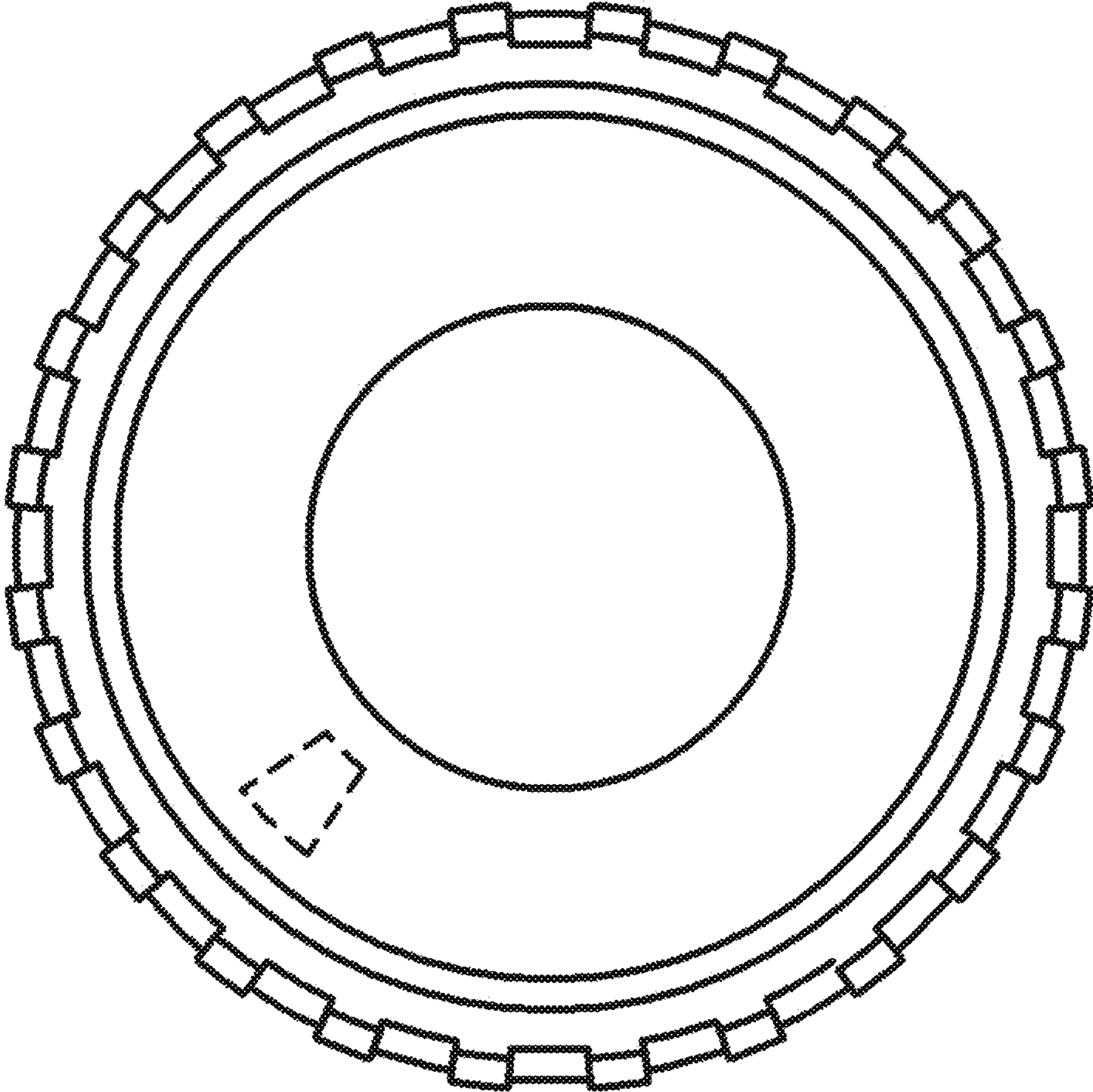

FIG. 11

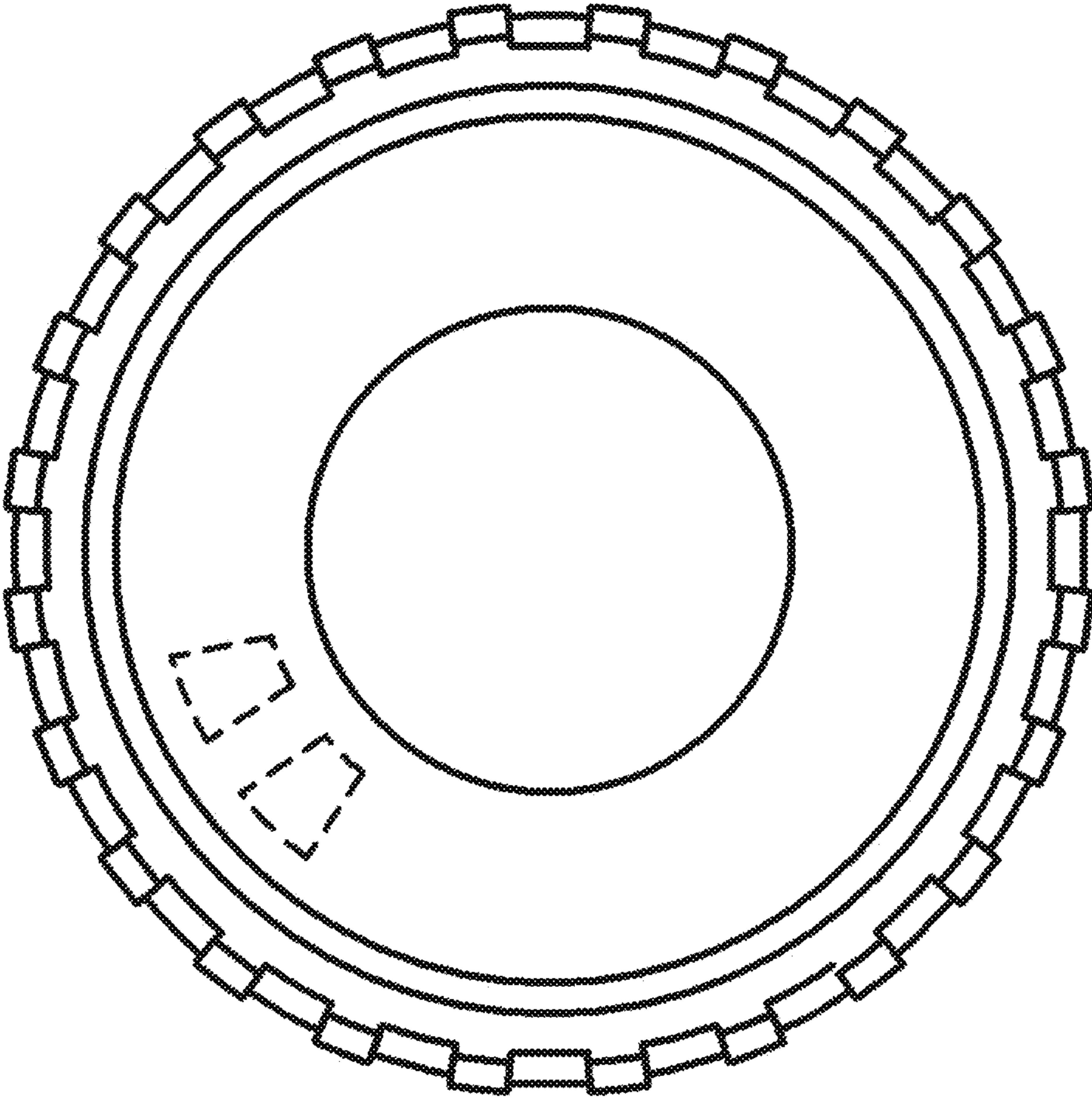

FIG. 12

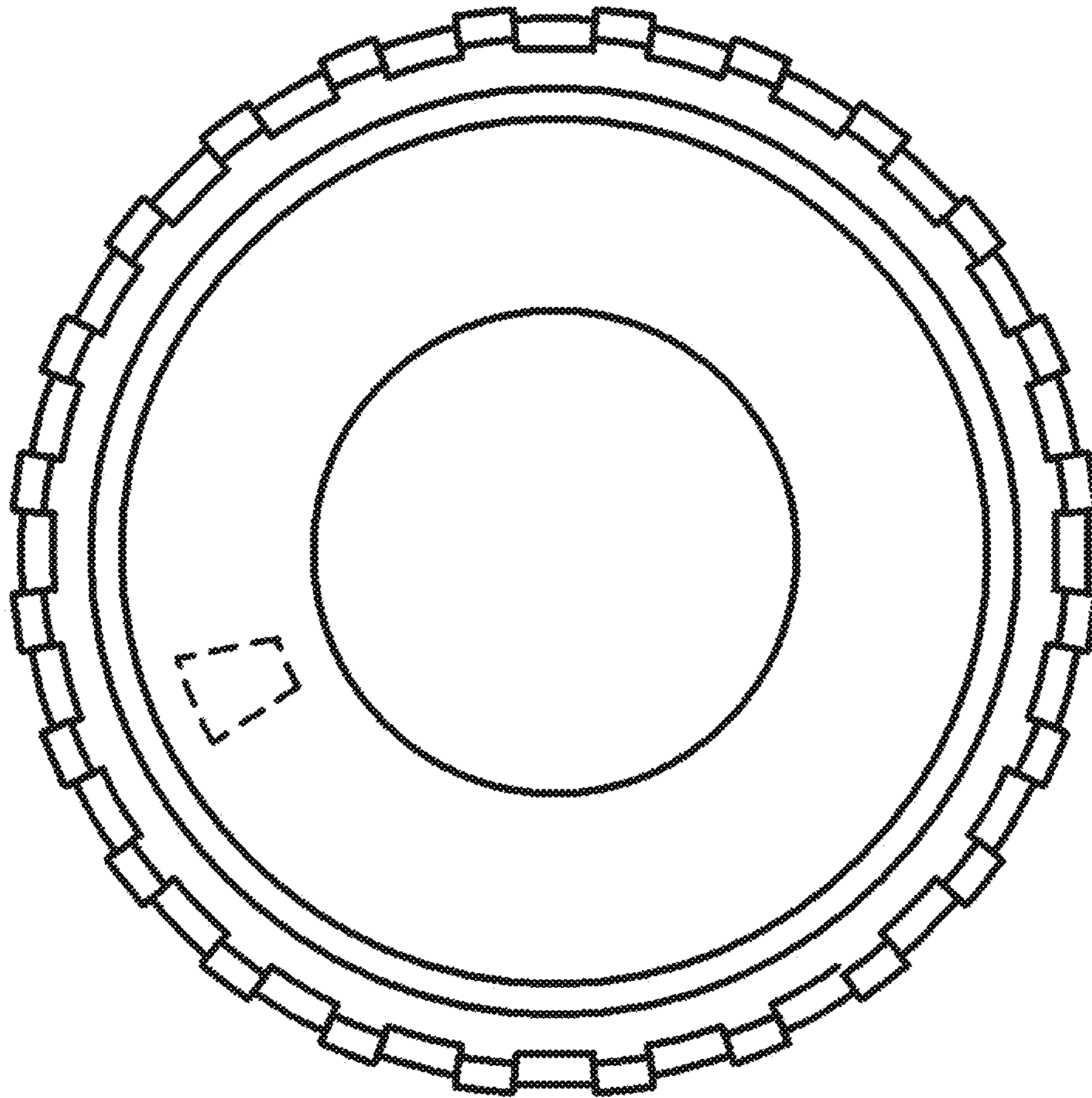

FIG. 13

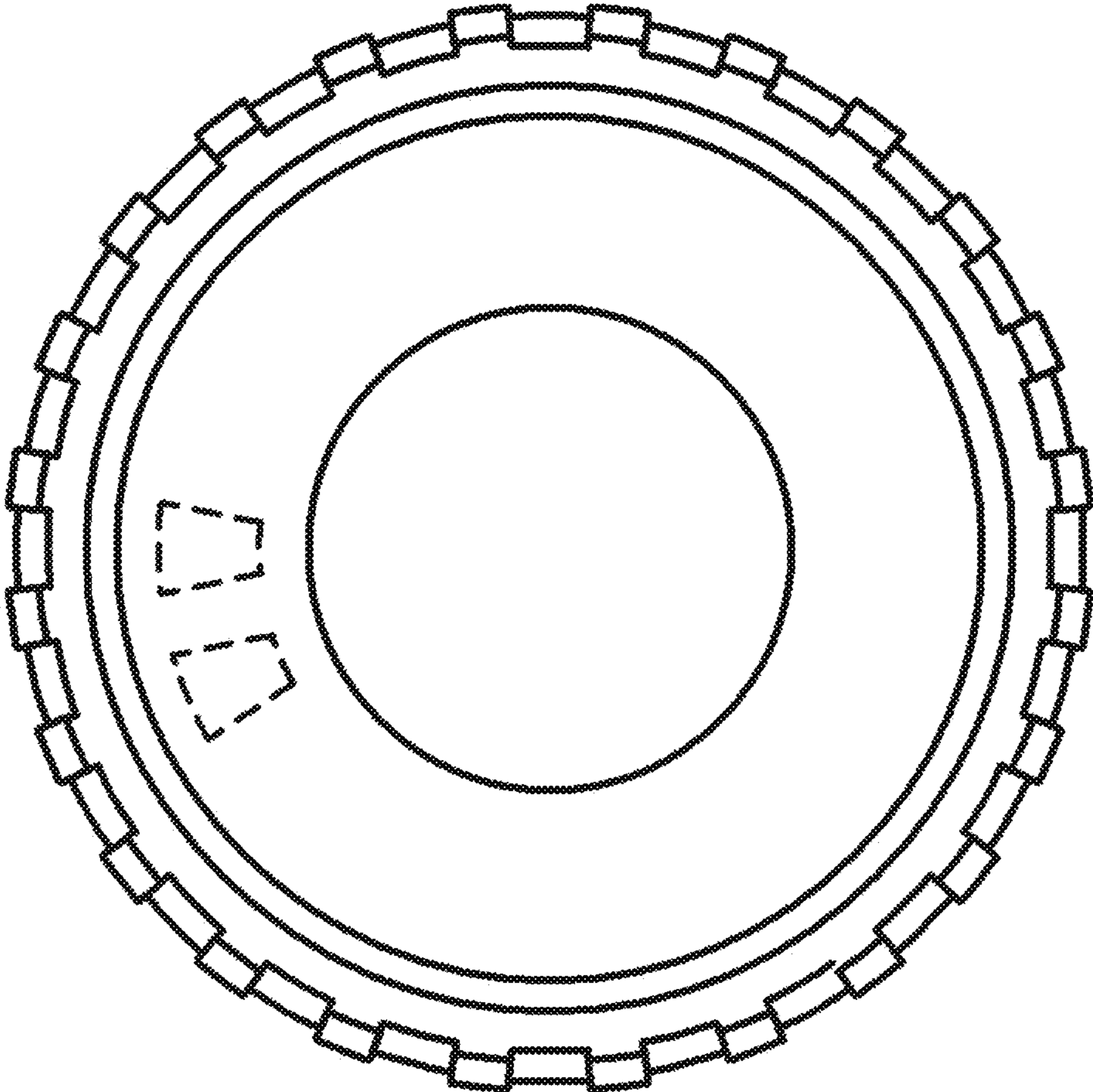

FIG. 14

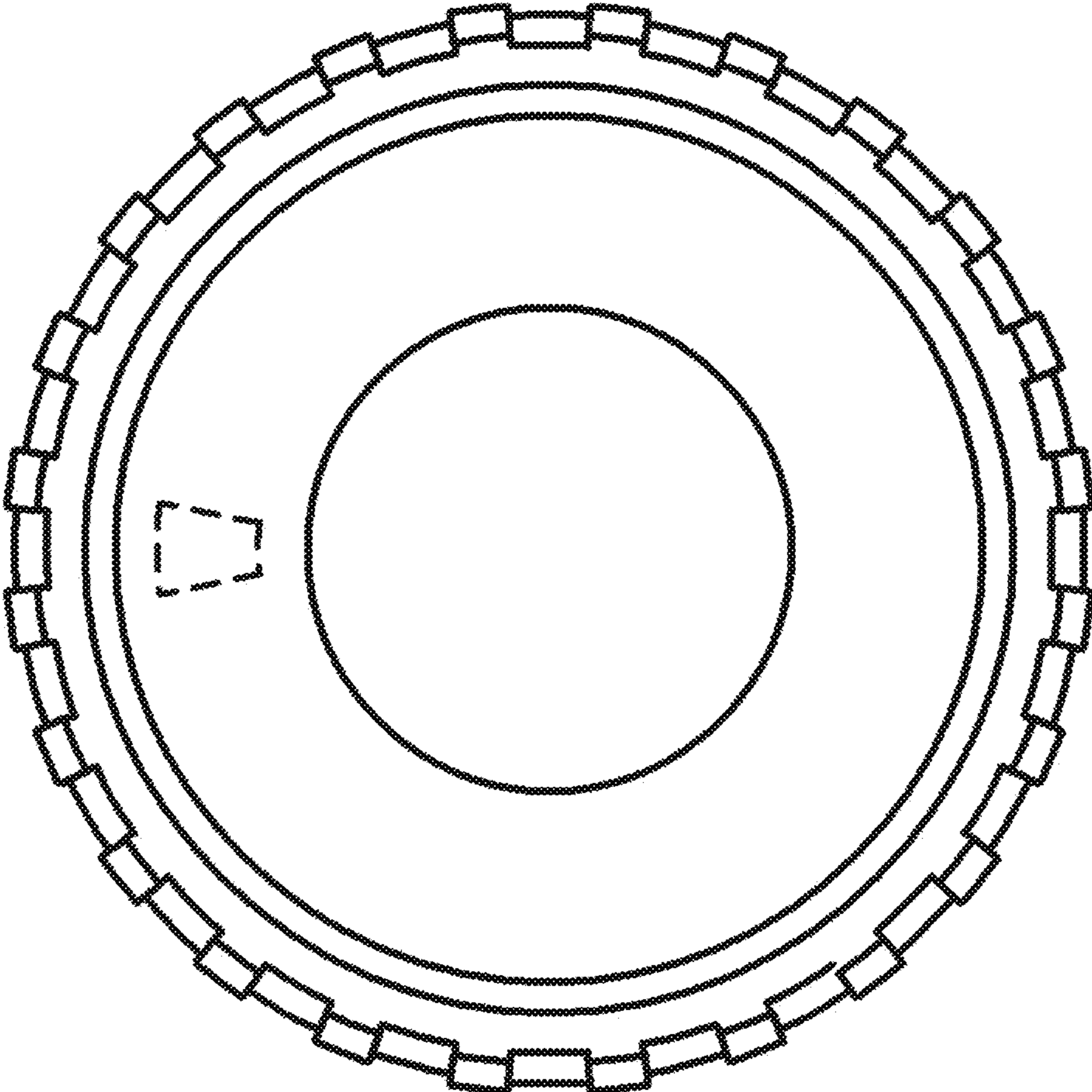

FIG. 15

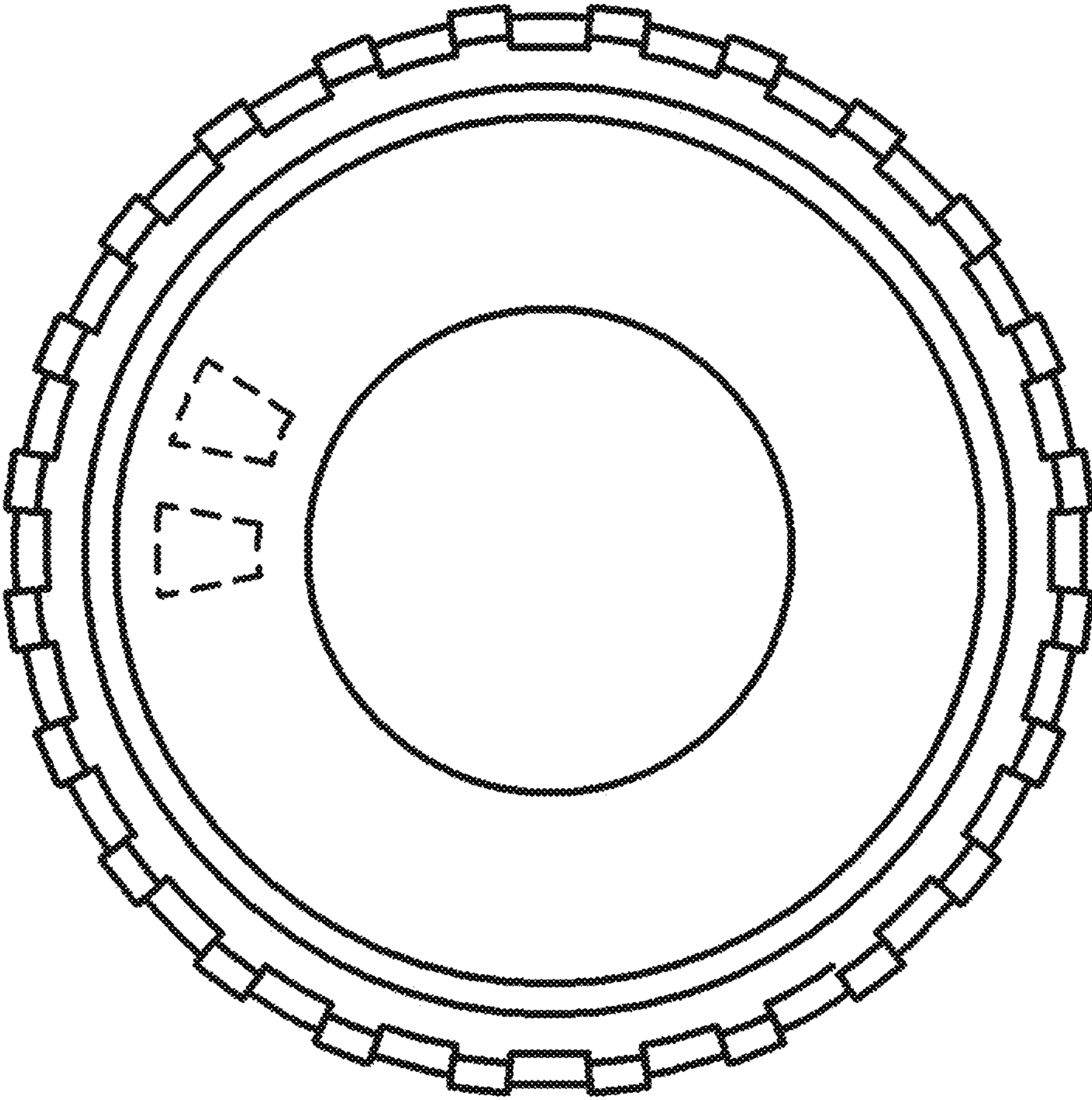

FIG. 16

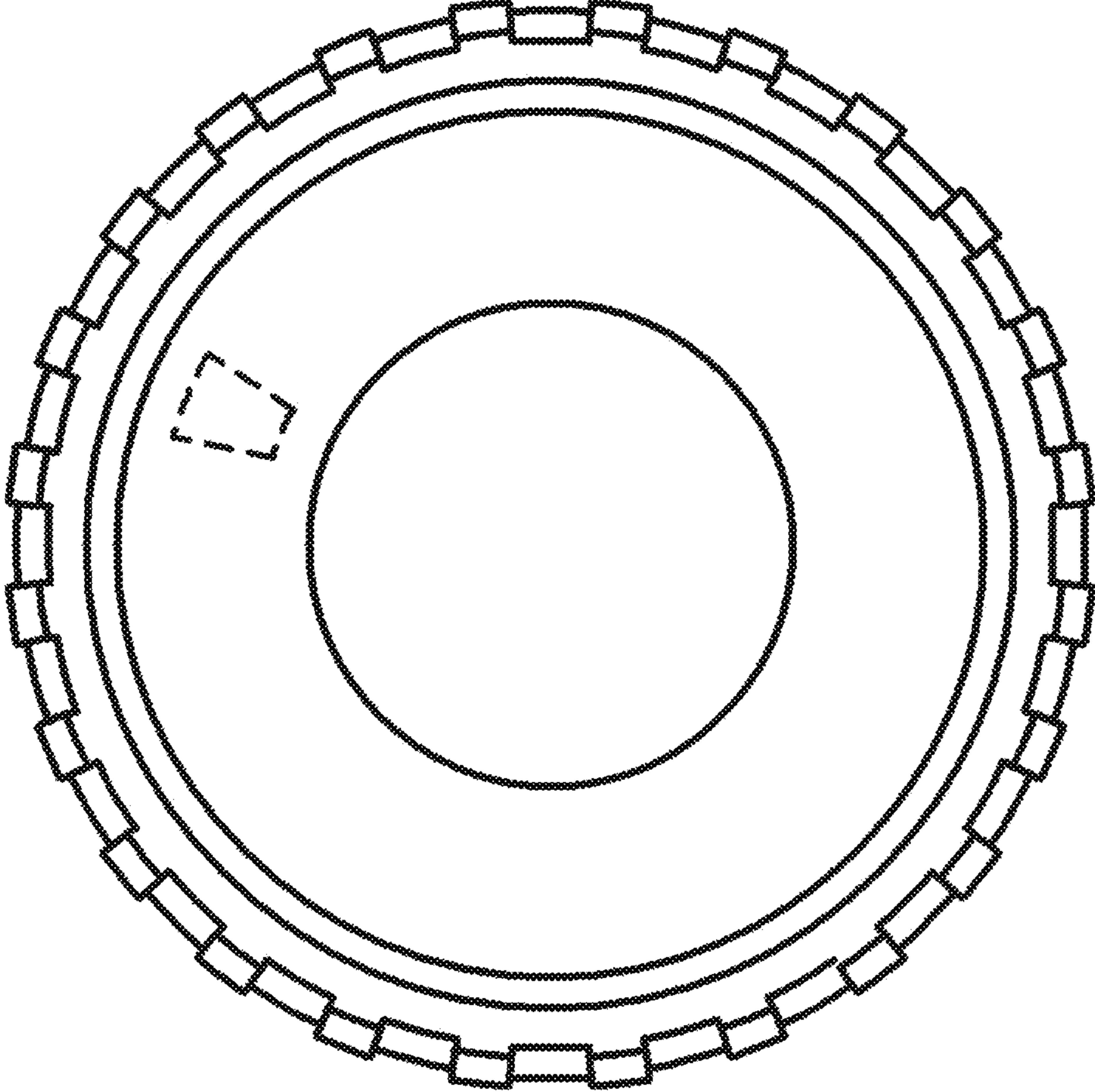

FIG. 17

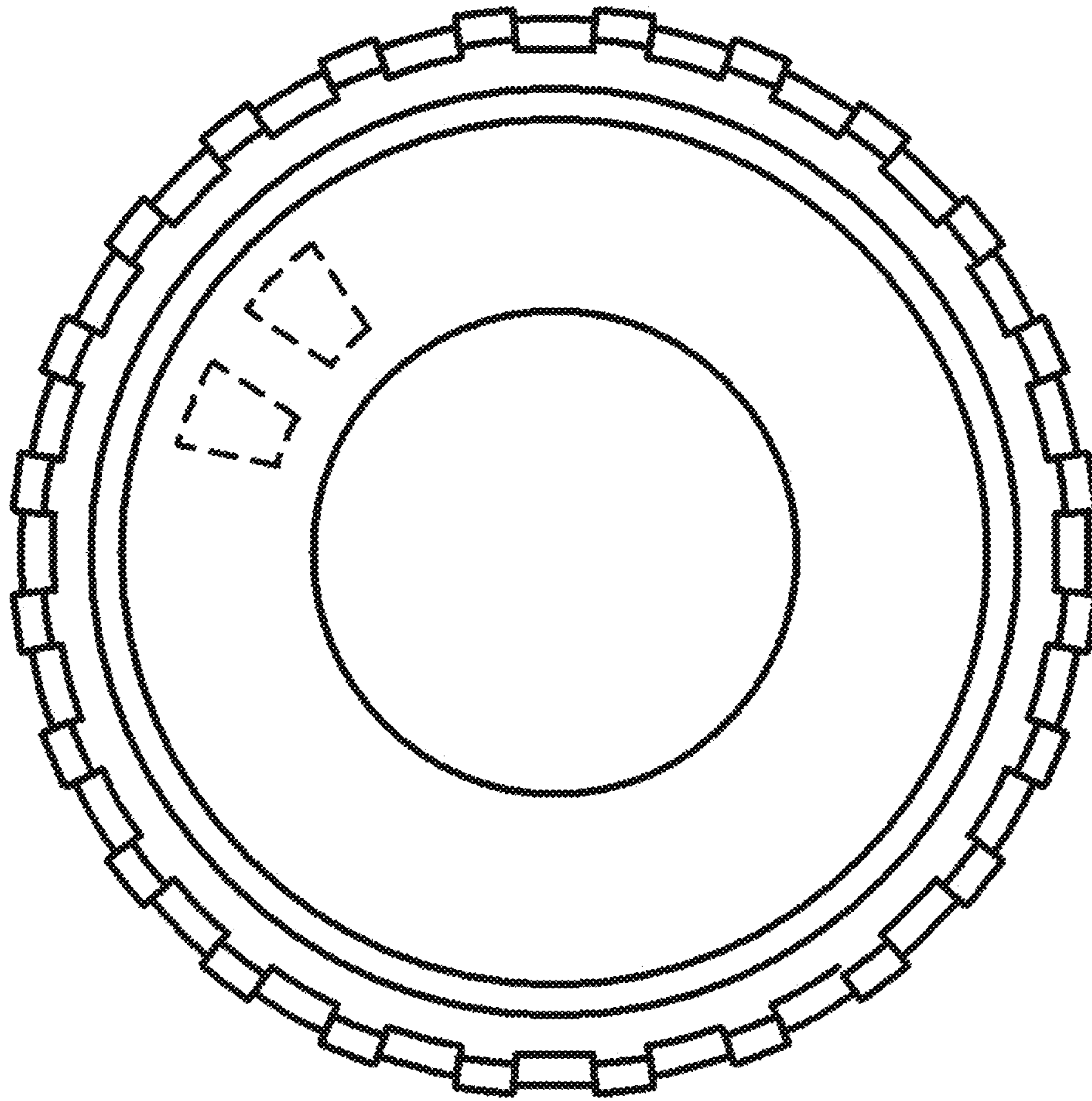

FIG. 18

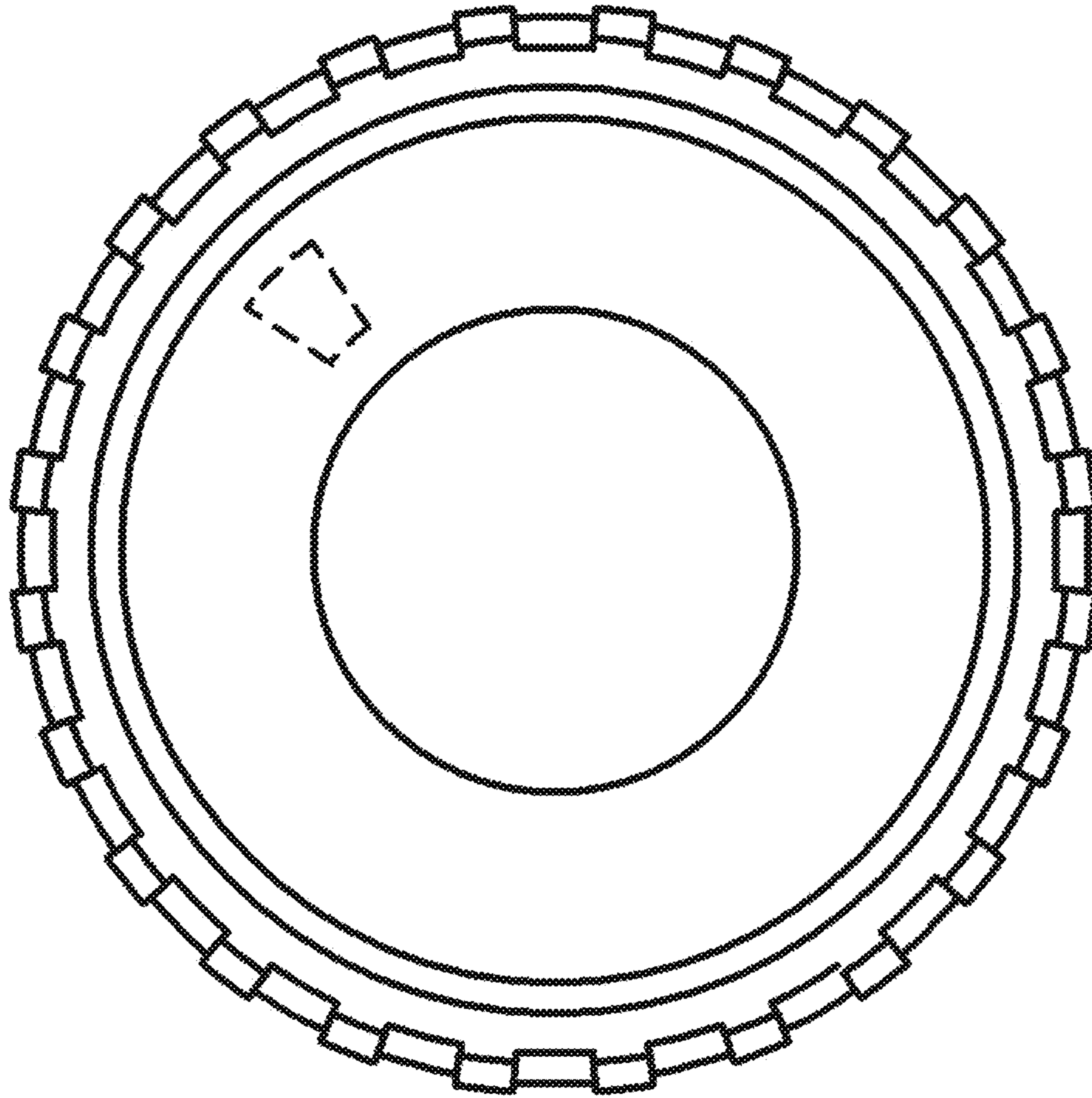

FIG. 19

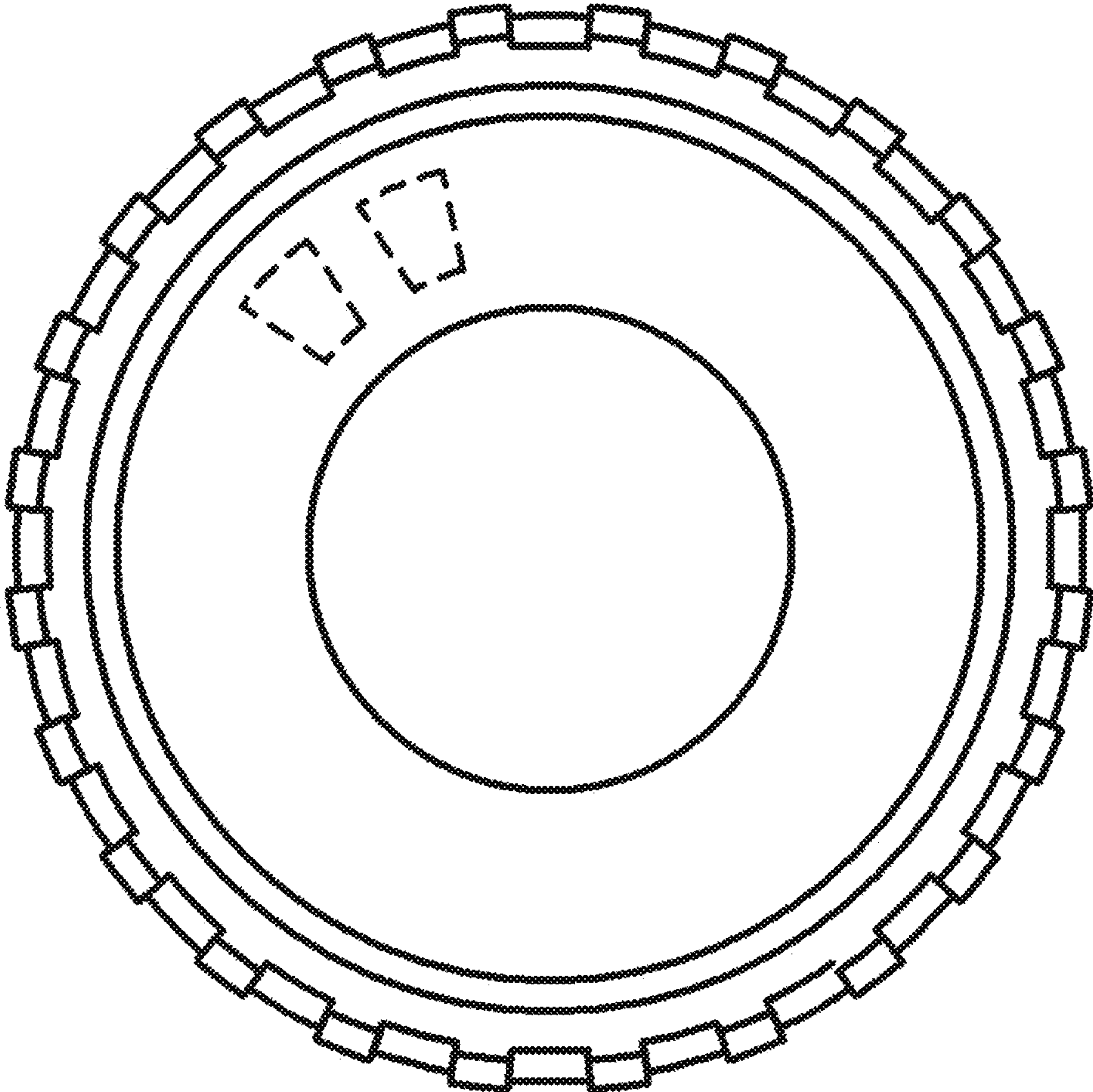

FIG. 20

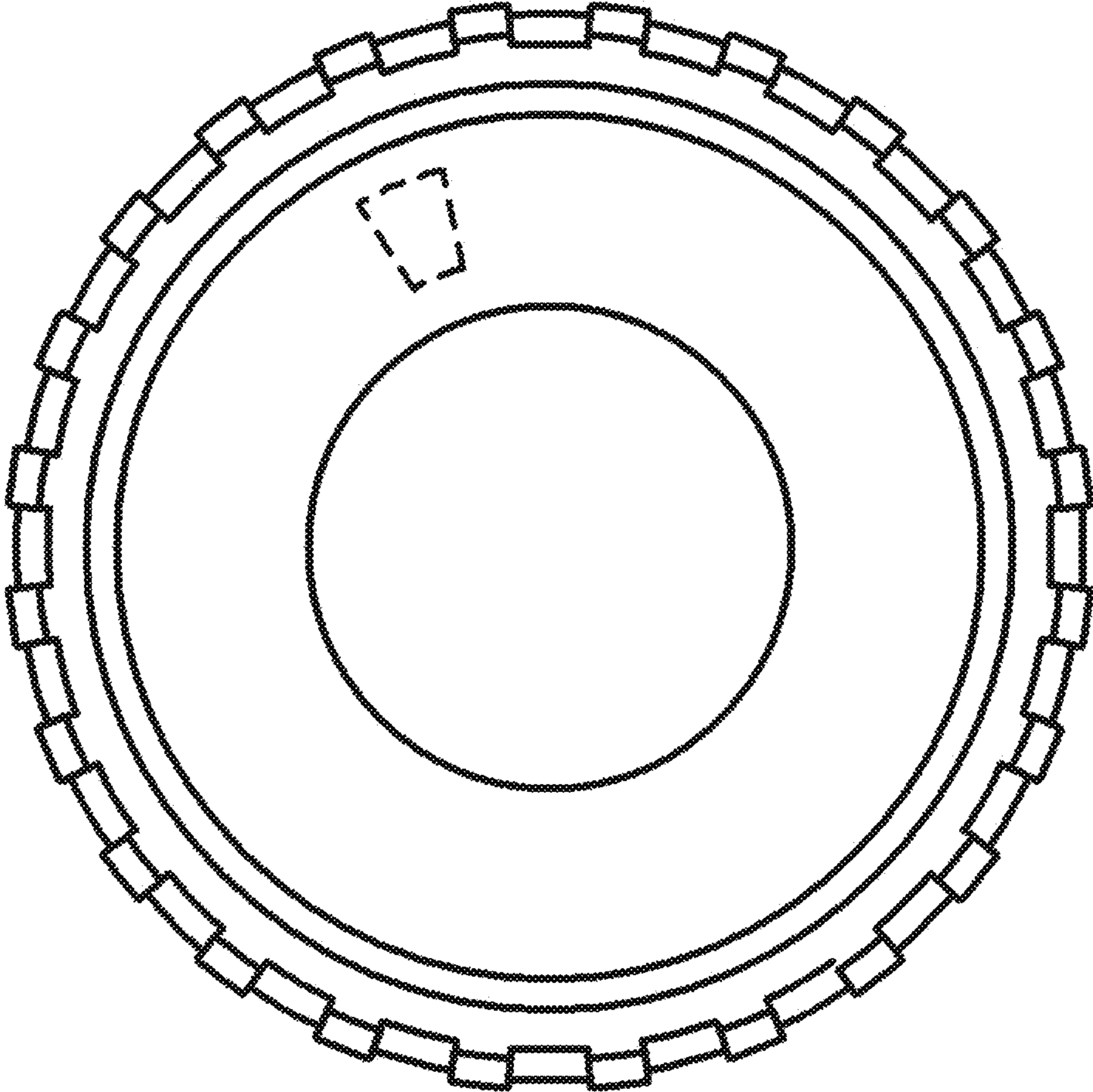

FIG. 21

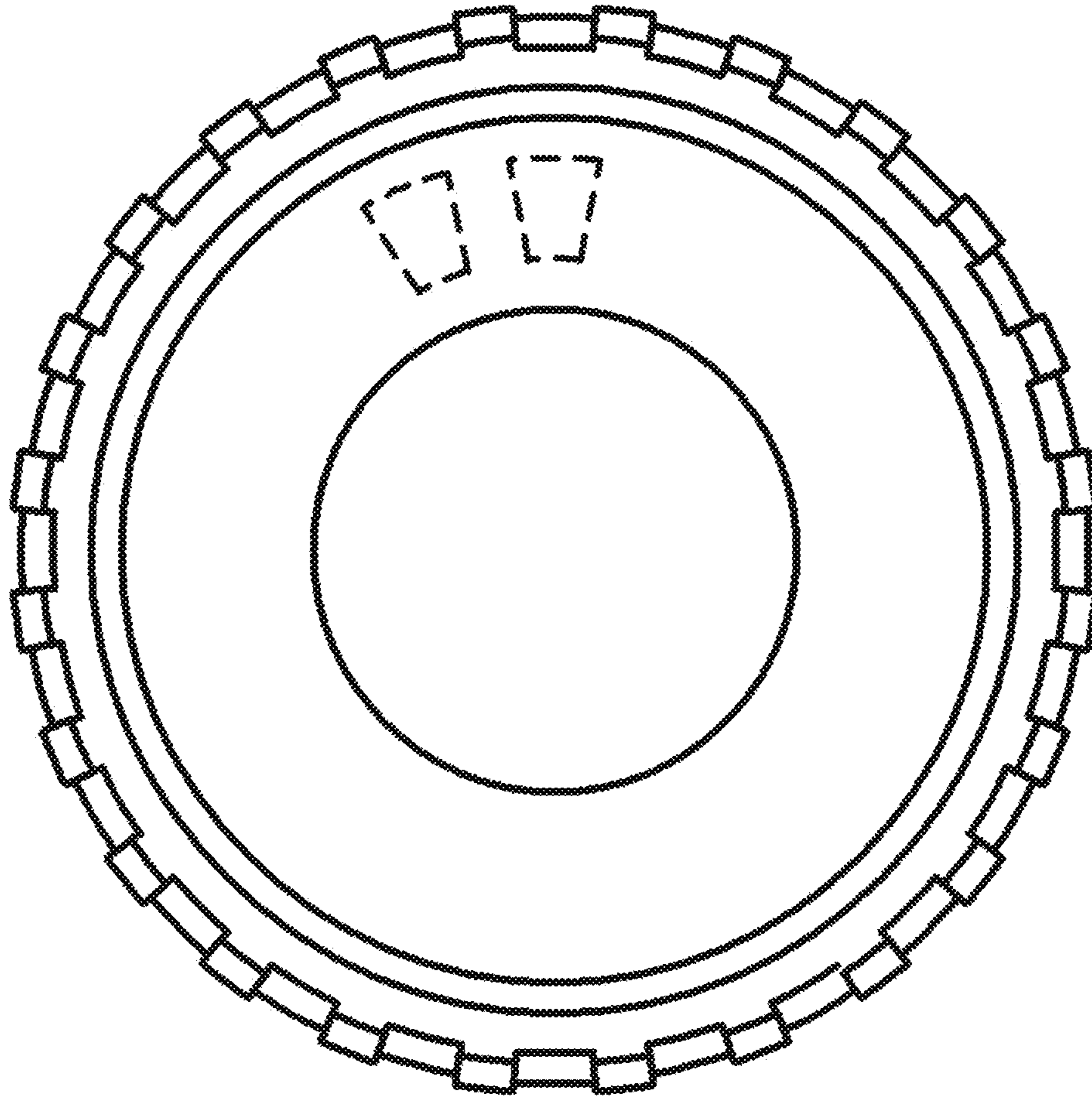

FIG. 22

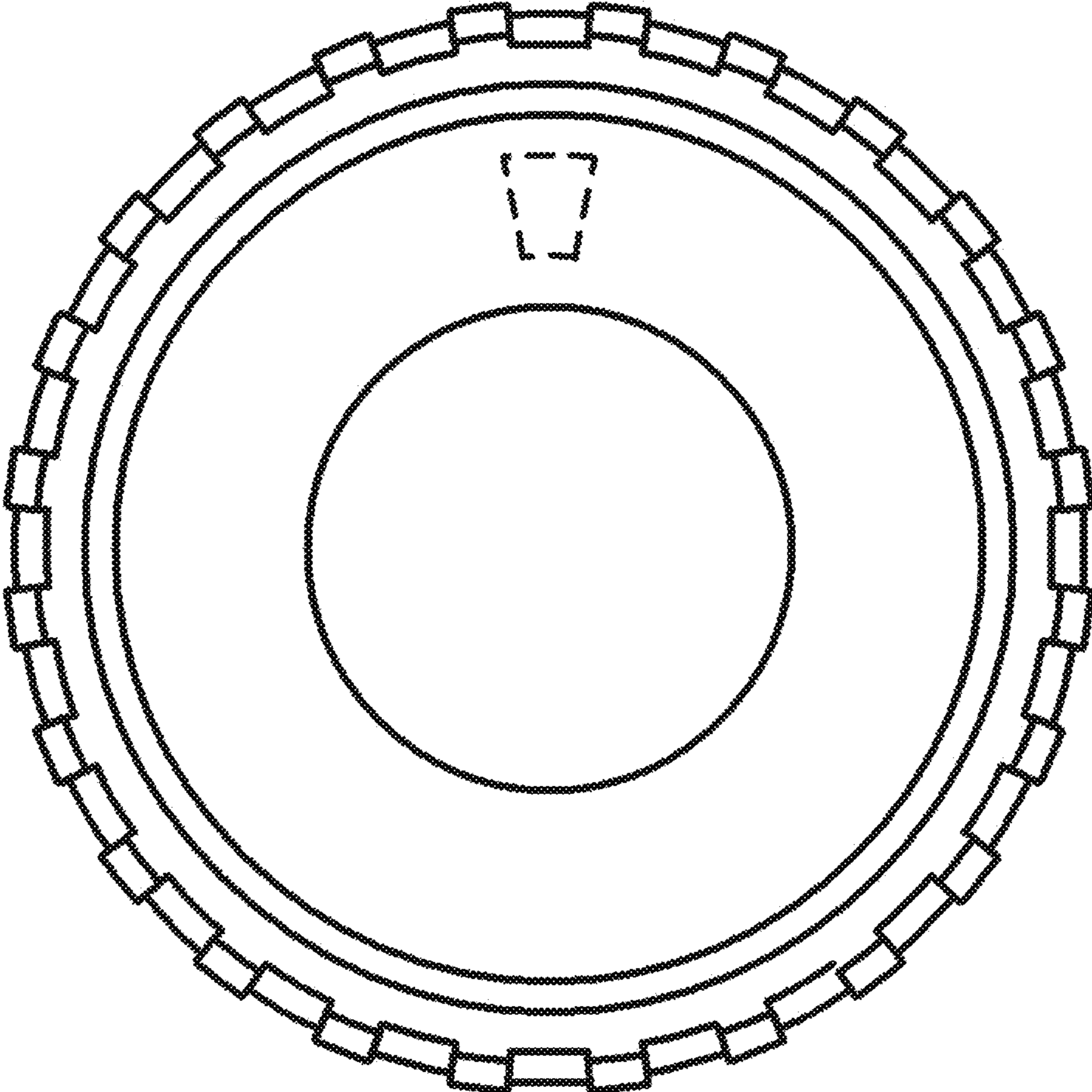

FIG. 23

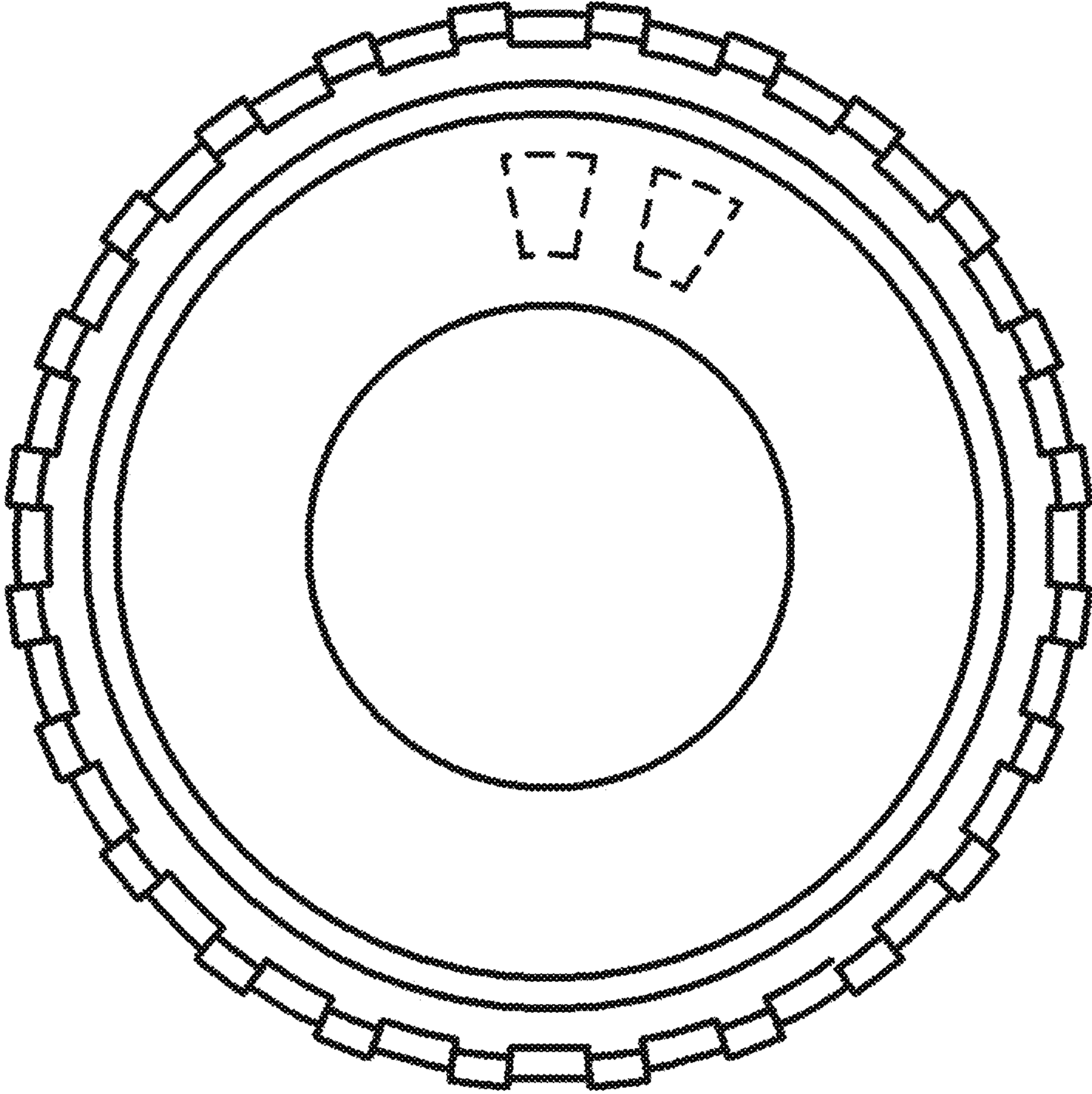

FIG. 24

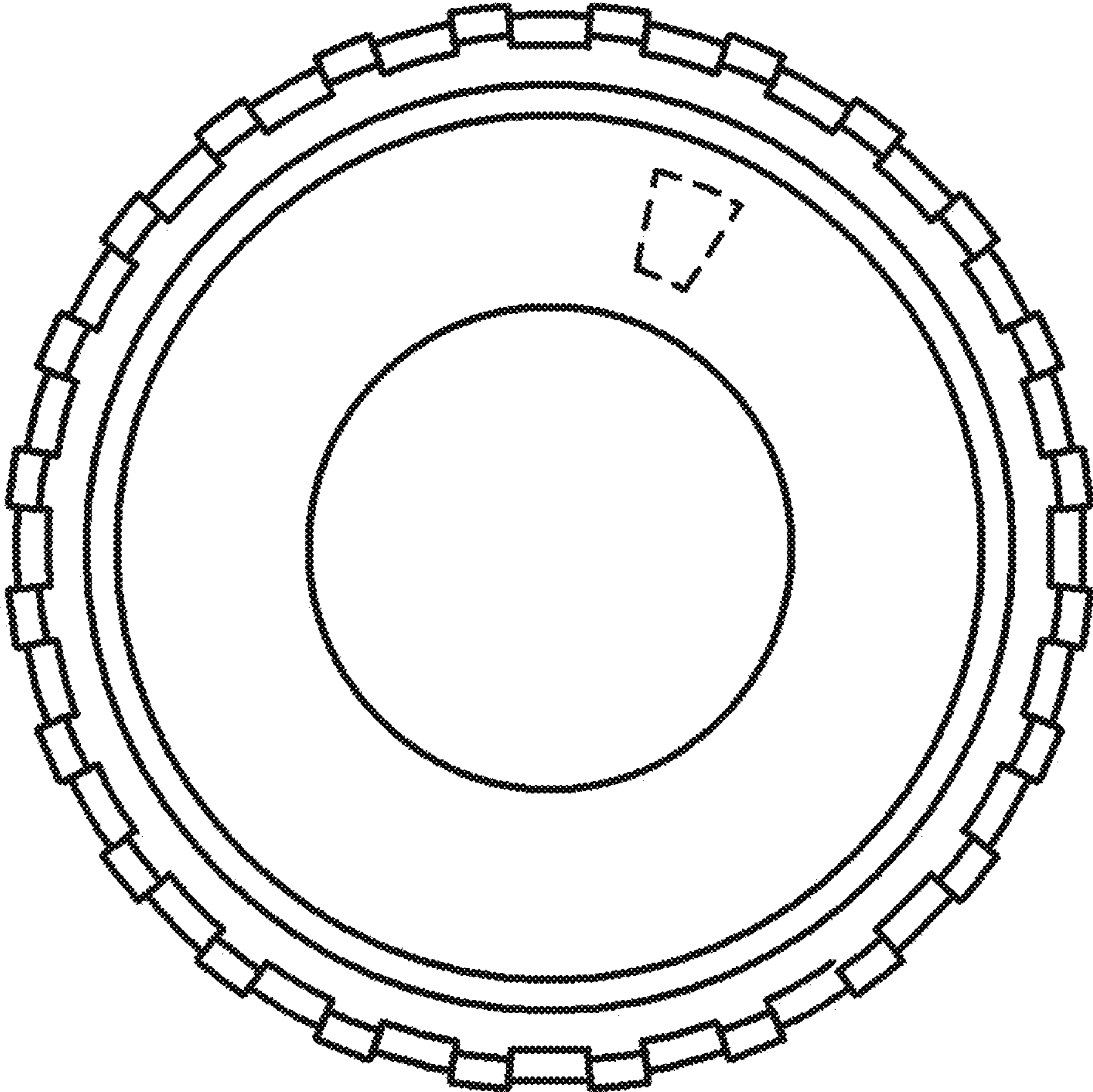

FIG. 25

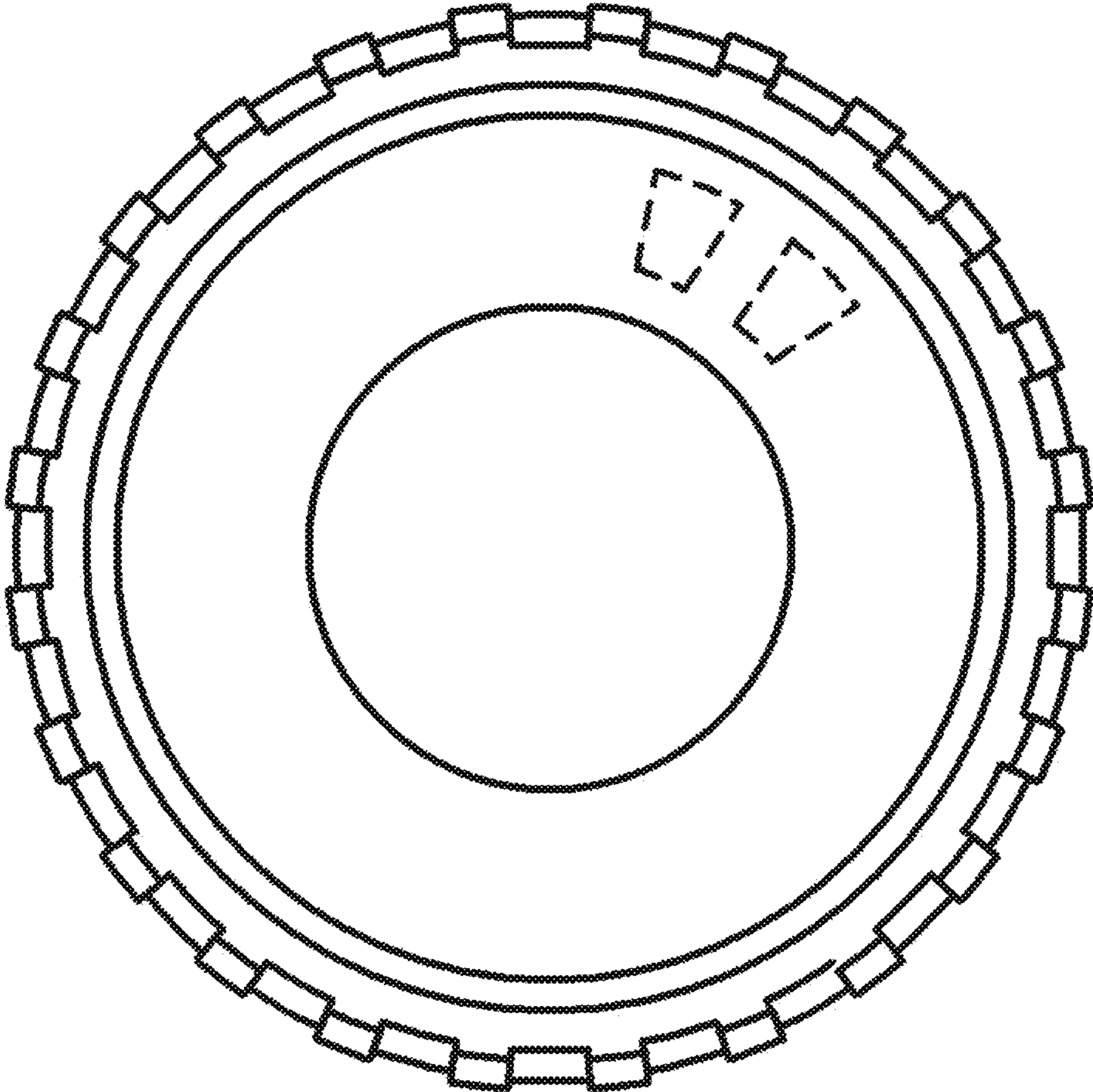

FIG. 26

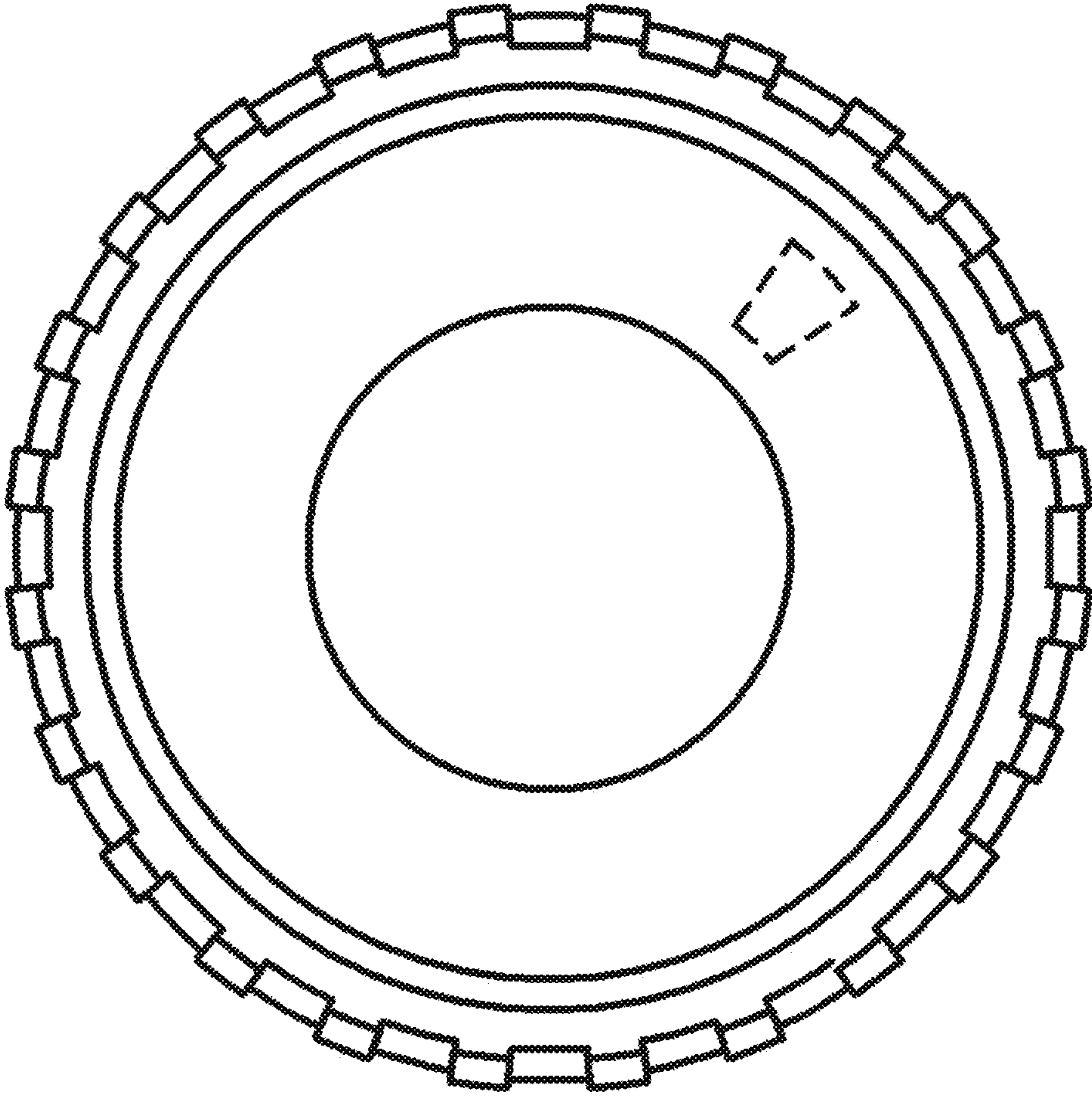

FIG. 27

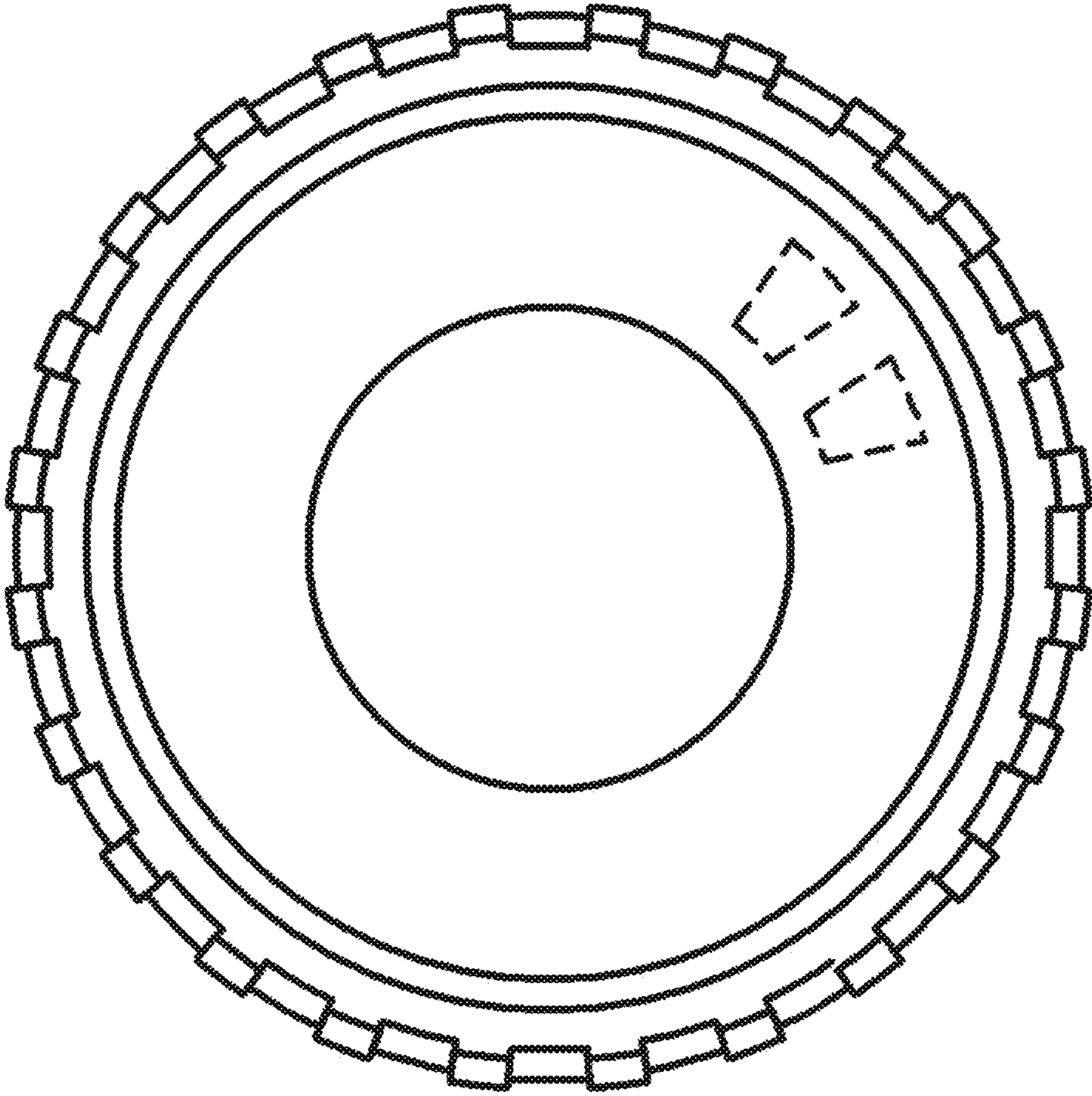

FIG. 28

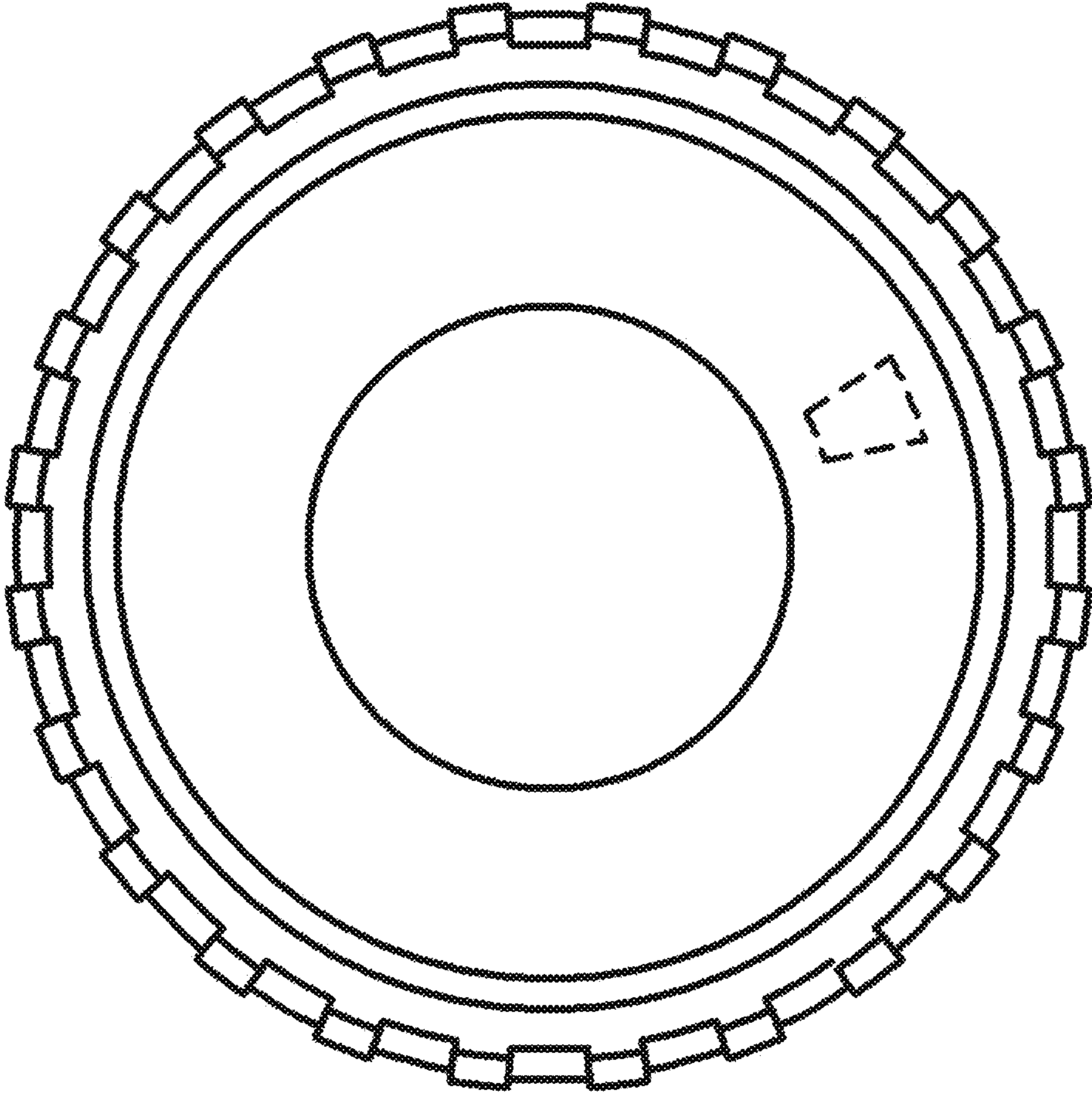

FIG. 29

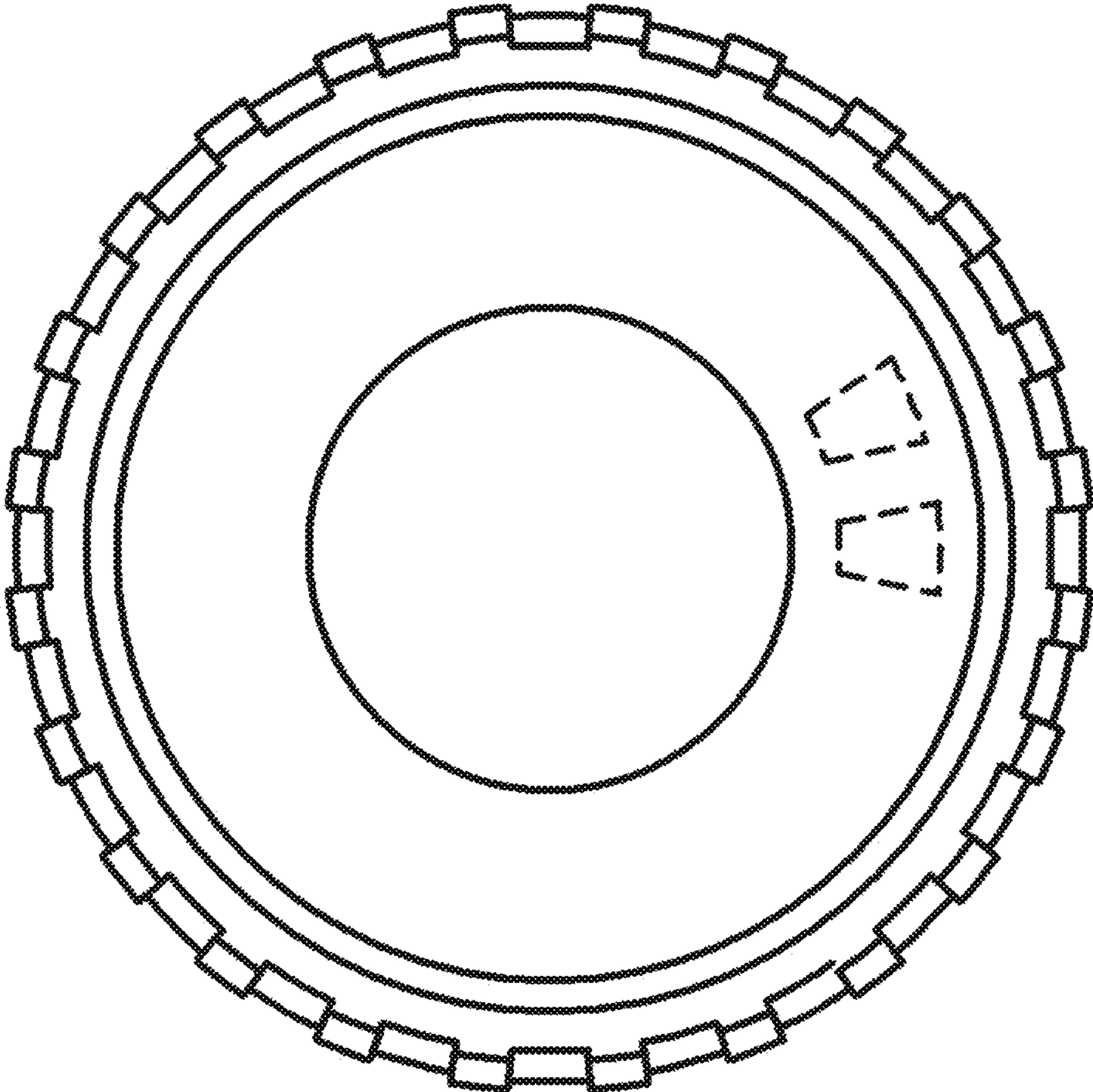

FIG. 30

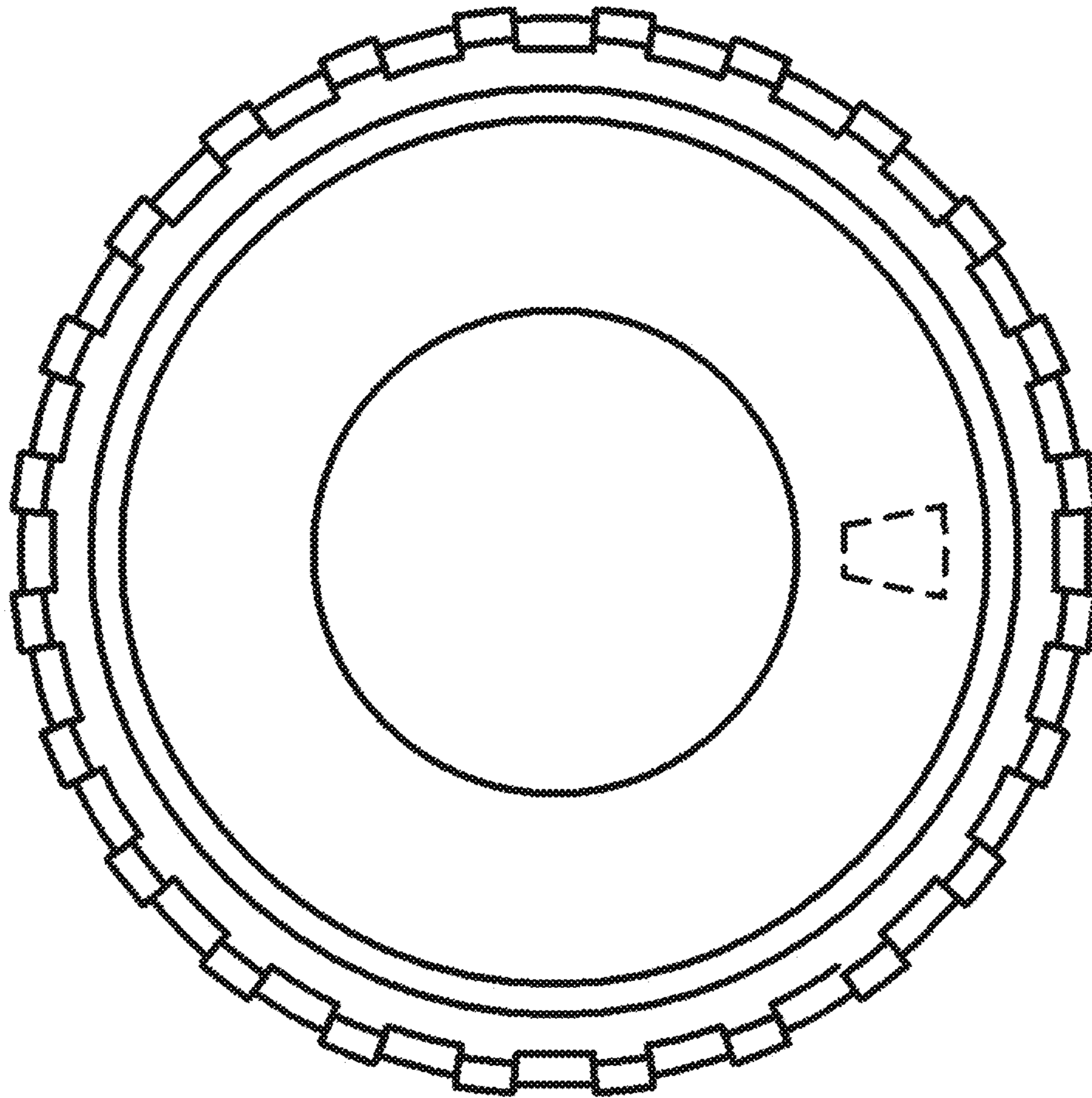

FIG. 31

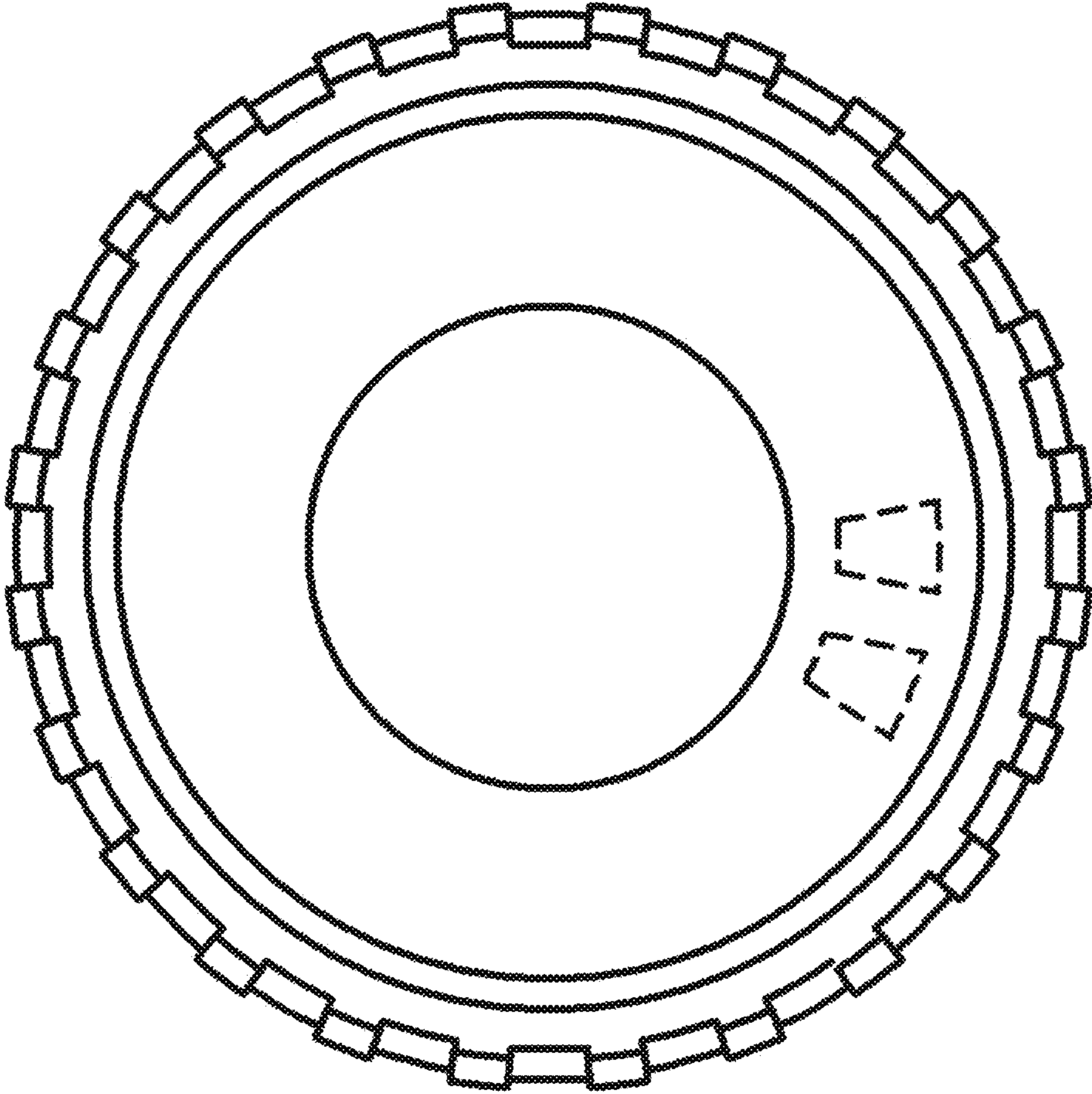

FIG. 32

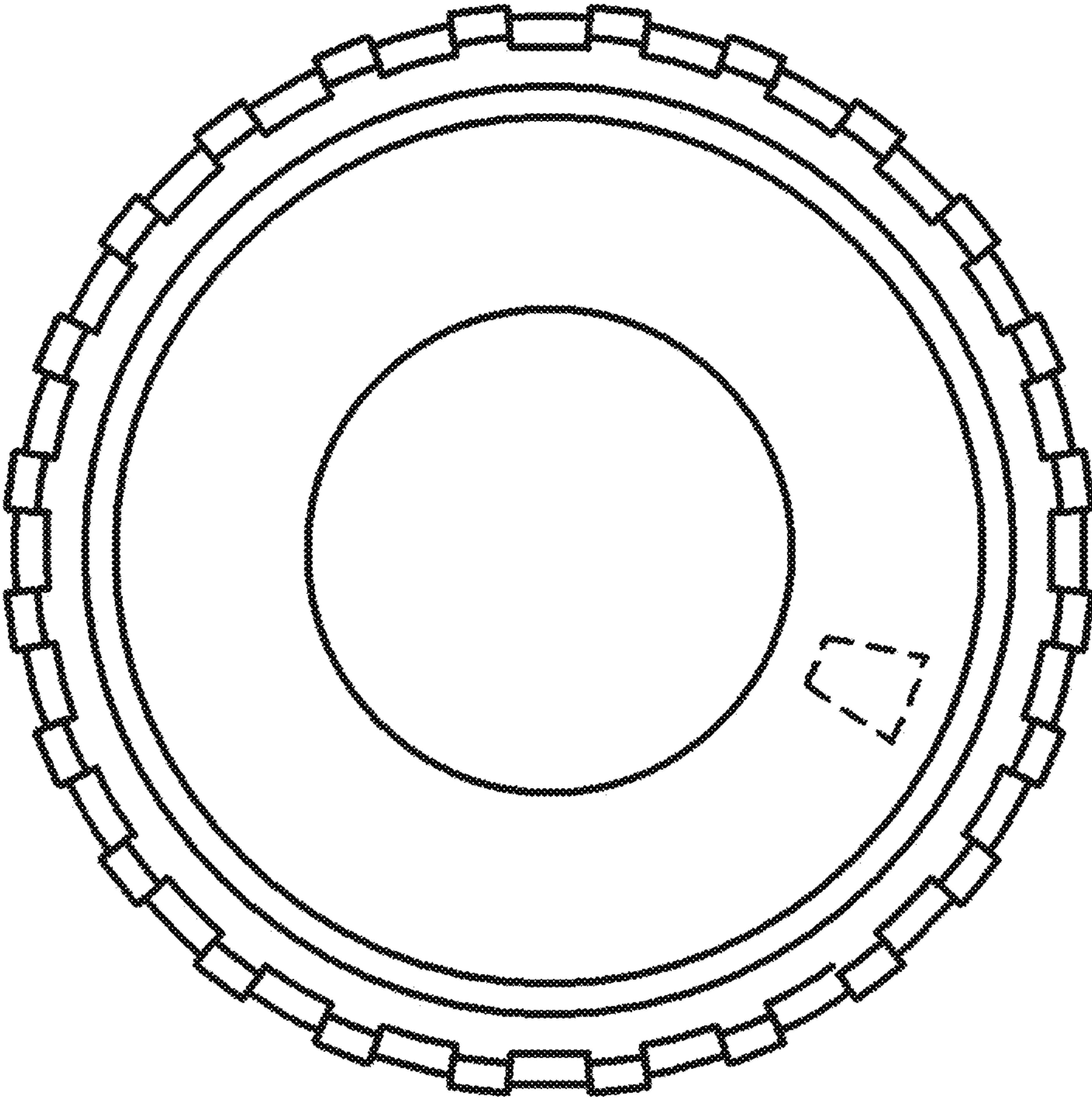

FIG. 33

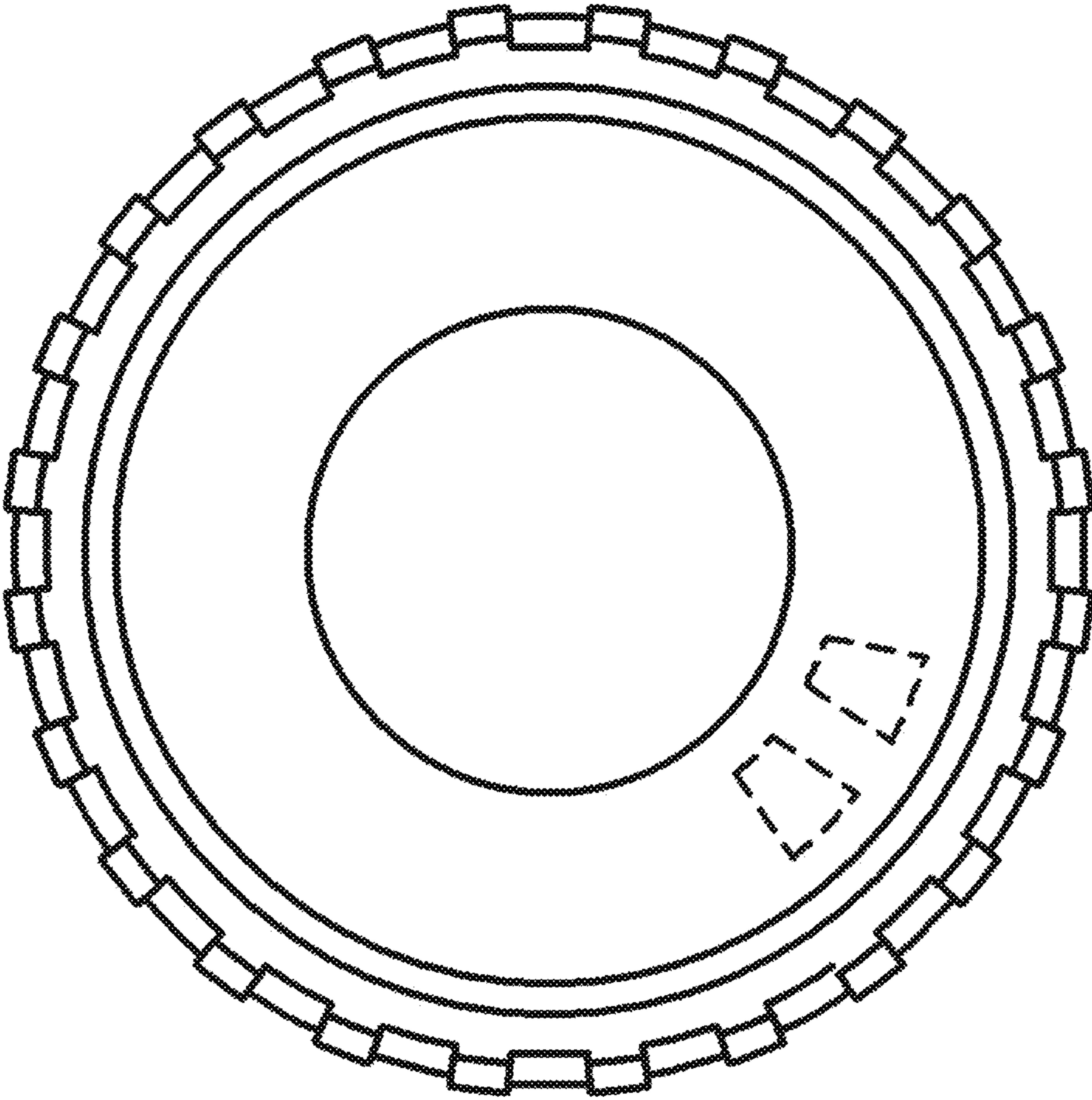

FIG. 34

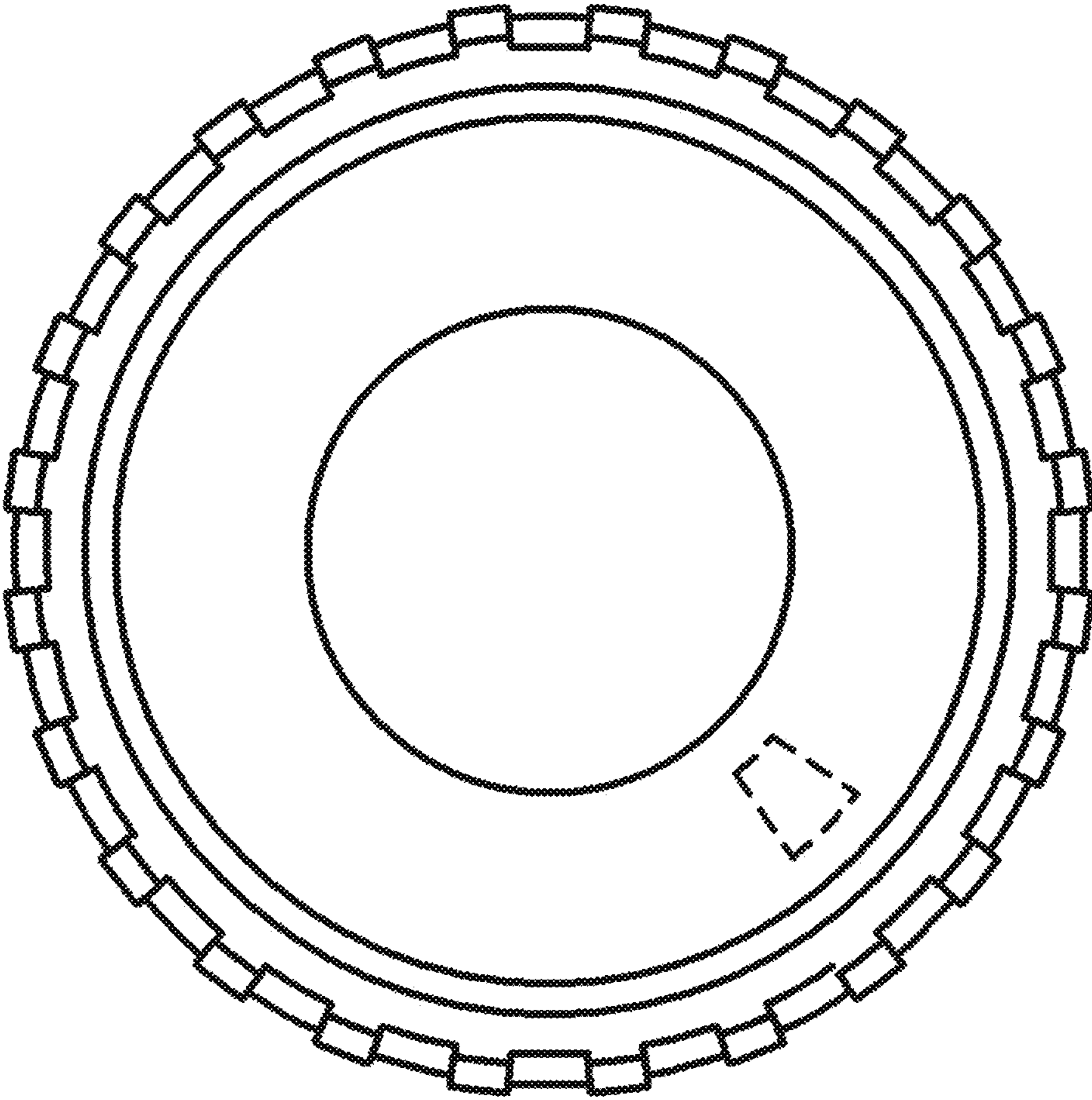

FIG. 35