

US00D966960S

(12) **United States Design Patent**  
**Kim et al.**

(10) **Patent No.:** **US D966,960 S**  
(45) **Date of Patent:** **\*\* Oct. 18, 2022**

(54) **REAR PORTION OF AN AUTOMOTIVE VEHICLE, TOY REPLICA AND/OR OTHER REPLICA**

(71) Applicant: **Atieva Inc.**, Uglan House (KY)

(72) Inventors: **Jiyeon Kim**, Palo Alto, CA (US);  
**Derek N. Jenkins**, Malibu, CA (US)

(73) Assignee: **Atieva Inc.**, Grand Cayman (KY)

(\*\*) Term: **15 Years**

(21) Appl. No.: **29/740,899**

(22) Filed: **Jul. 8, 2020**

(51) **LOC (13) Cl.** ..... **12-16**

(52) **U.S. Cl.**  
USPC ..... **D12/164**

(58) **Field of Classification Search**  
USPC ..... D12/86, 90-92, 164; D21/433, 434,  
D21/531-535; 296/181.1-181.5, 183.1  
CPC ..... B62D 25/00; B62D 25/06; B62D 33/00;  
B62D 35/00  
See application file for complete search history.

(56) **References Cited**

**U.S. PATENT DOCUMENTS**

D803,733 S	*	11/2017	Cartabiano	.....	D12/164
D804,357 S	*	12/2017	Jeon	.....	D12/91
D821,268 S	*	6/2018	Kim	.....	D12/92
D835,000 S	*	12/2018	Tomasson	.....	D12/91
D856,195 S	*	8/2019	Kim	.....	D12/92
D873,718 S	*	1/2020	Sperling	.....	D12/92
D913,849 S	*	3/2021	Nurnberger	.....	D12/91
D932,945 S	*	10/2021	Ohnuma	.....	D12/92

**OTHER PUBLICATIONS**

Photos of Lucid Motors AIR™ prototype vehicle exterior, published prior to Jun. 2019.

Photo of Dodge Charger, published or publically used prior to Jun. 2019.

R. Moore, Lucid Motors Air™ prototype vehicle review article, TopSpeed, published Aug. 25, 2017.

\* cited by examiner

*Primary Examiner* — Melody N Brown

(57) **CLAIM**

The ornamental design for a rear portion of an automotive vehicle, toy replica and/or other replica, as shown and described.

**DESCRIPTION**

FIG. 1 is a top, front and side perspective view of a rear portion of an automotive vehicle, toy replica and/or other replica showing our new design;

FIG. 2 is a rear elevational view thereof;

FIG. 3 is a front elevational view thereof;

FIG. 4 is a side elevational view thereof;

FIG. 5 is an opposite side elevational view thereof;

FIG. 6 is a top plan view thereof;

FIG. 7 is a bottom plan view thereof; and,

FIG. 8 is an enlarged fragmentary front elevational view thereof, taken along line 8-8 in FIG. 3.

The portions of the automobile vehicle and the trademark "LUCID" shown in broken lines throughout the drawing views are for illustrative and environmental purposes and form no part of the claimed design.

**1 Claim, 7 Drawing Sheets**

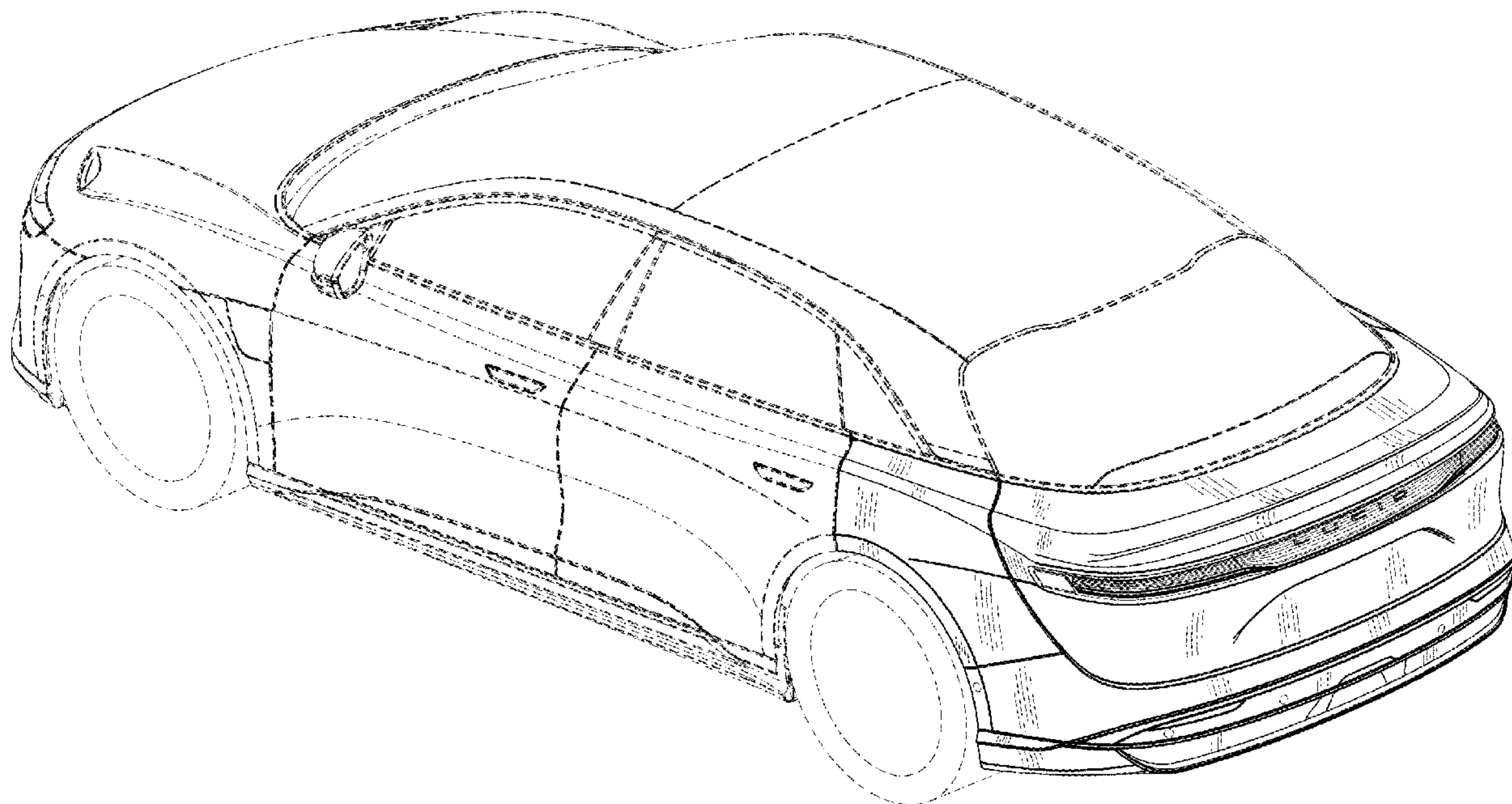

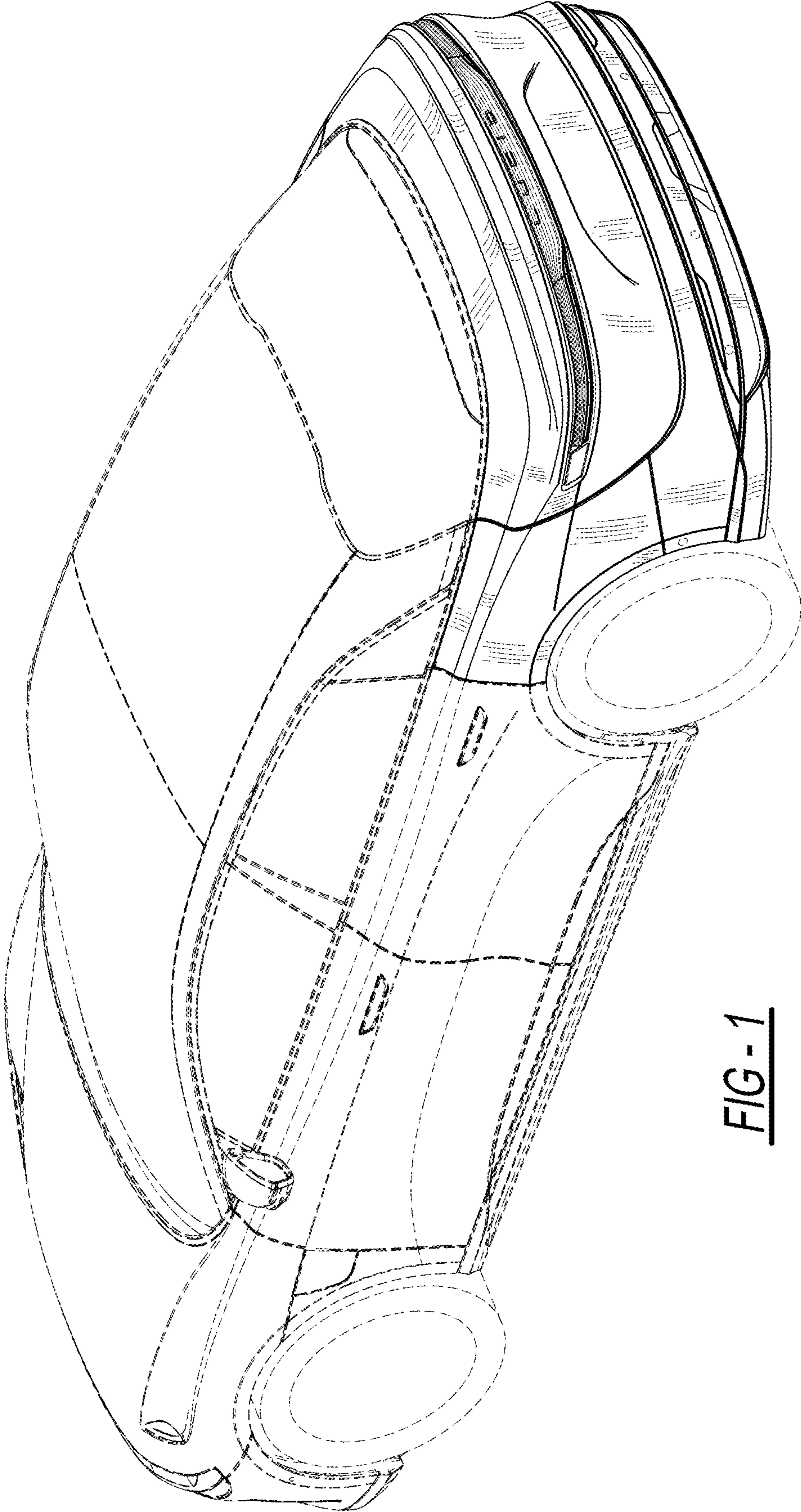

FIG - 1



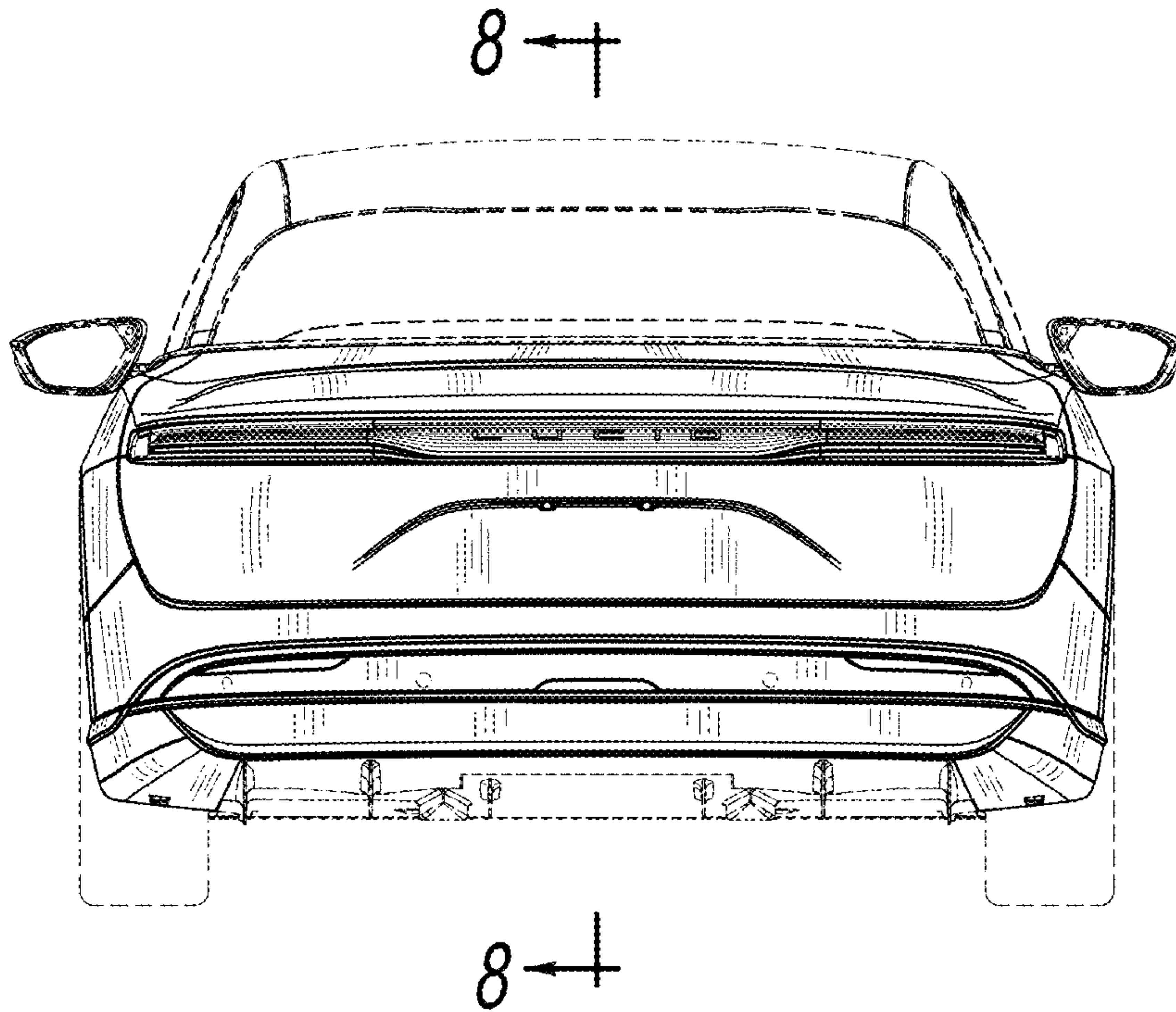
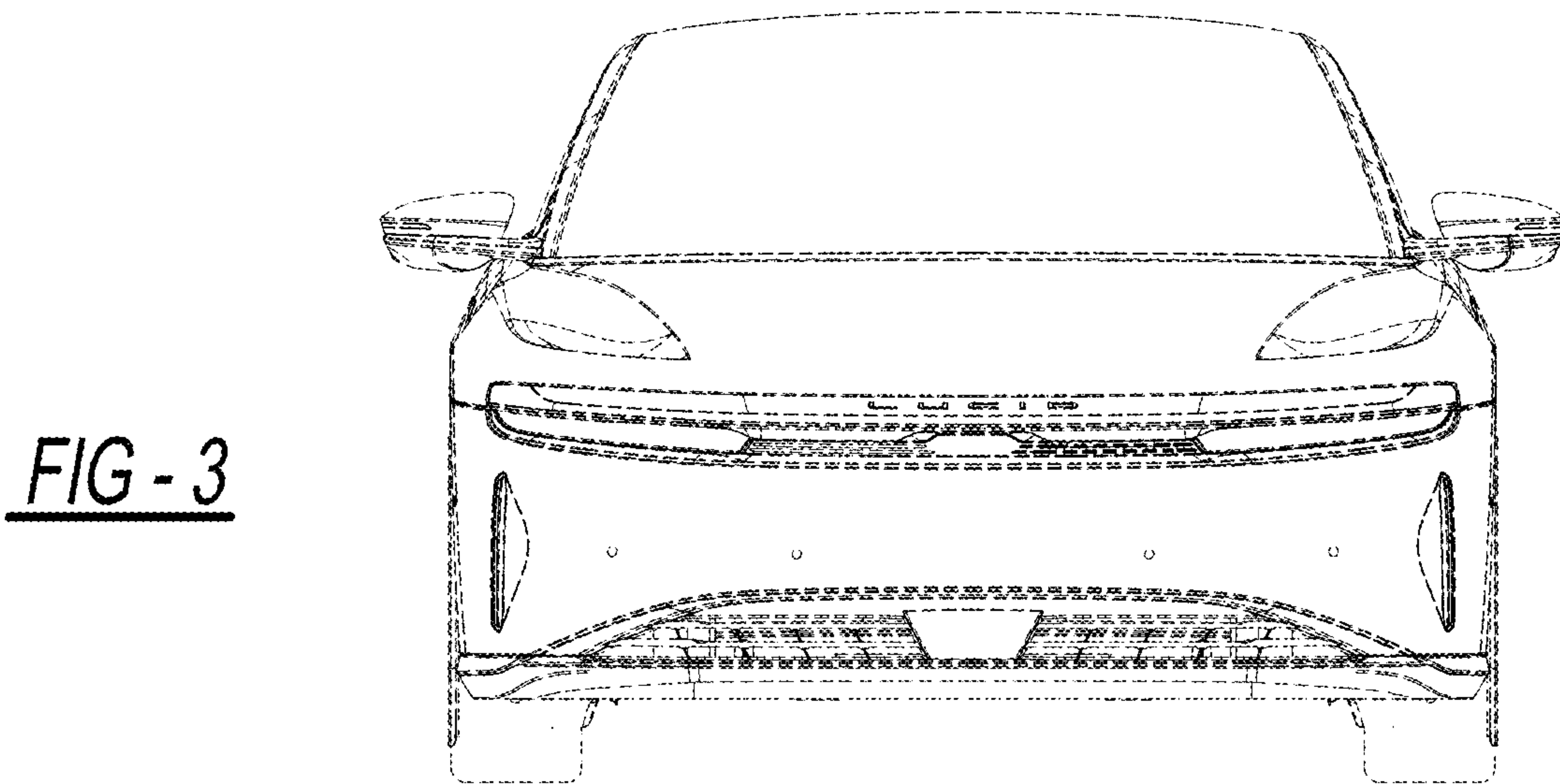

FIG - 2



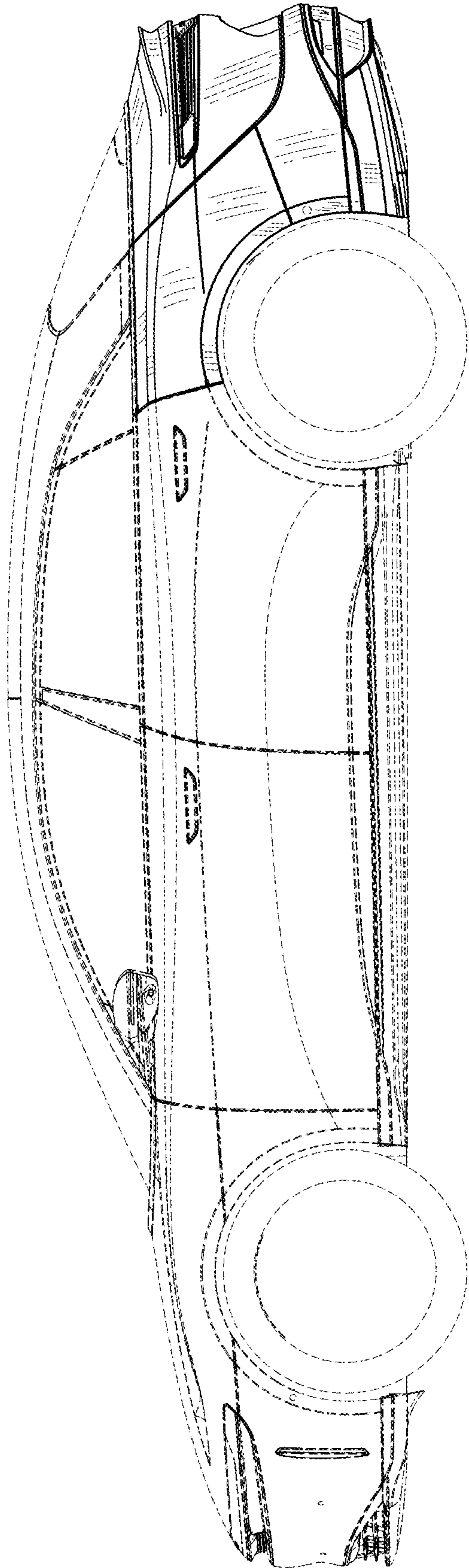

FIG - 4

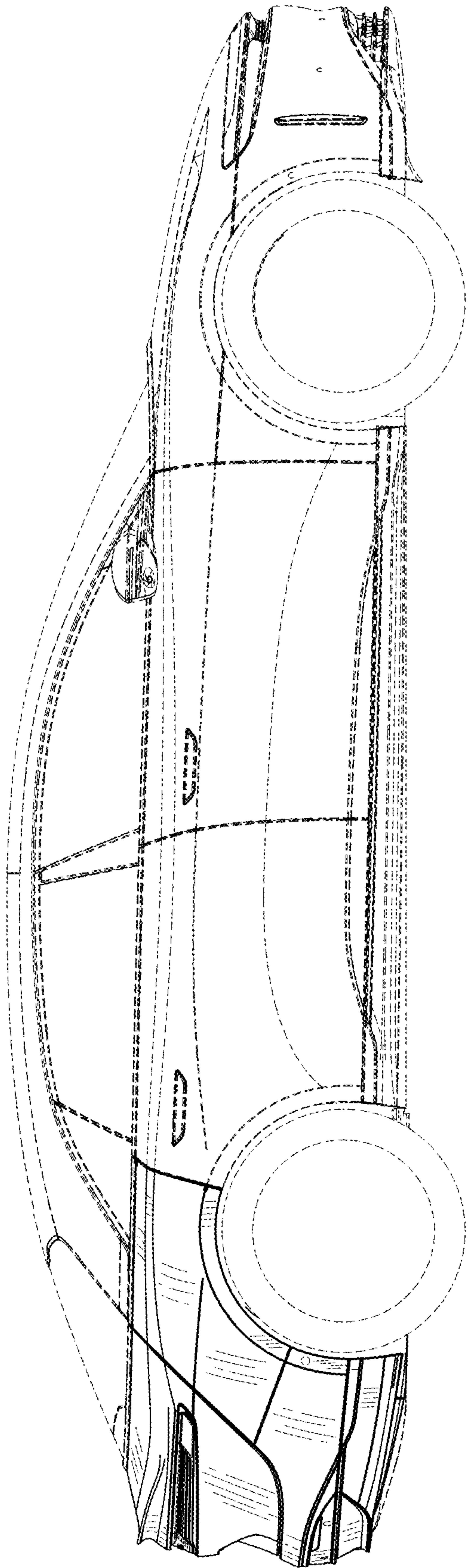

FIG - 5



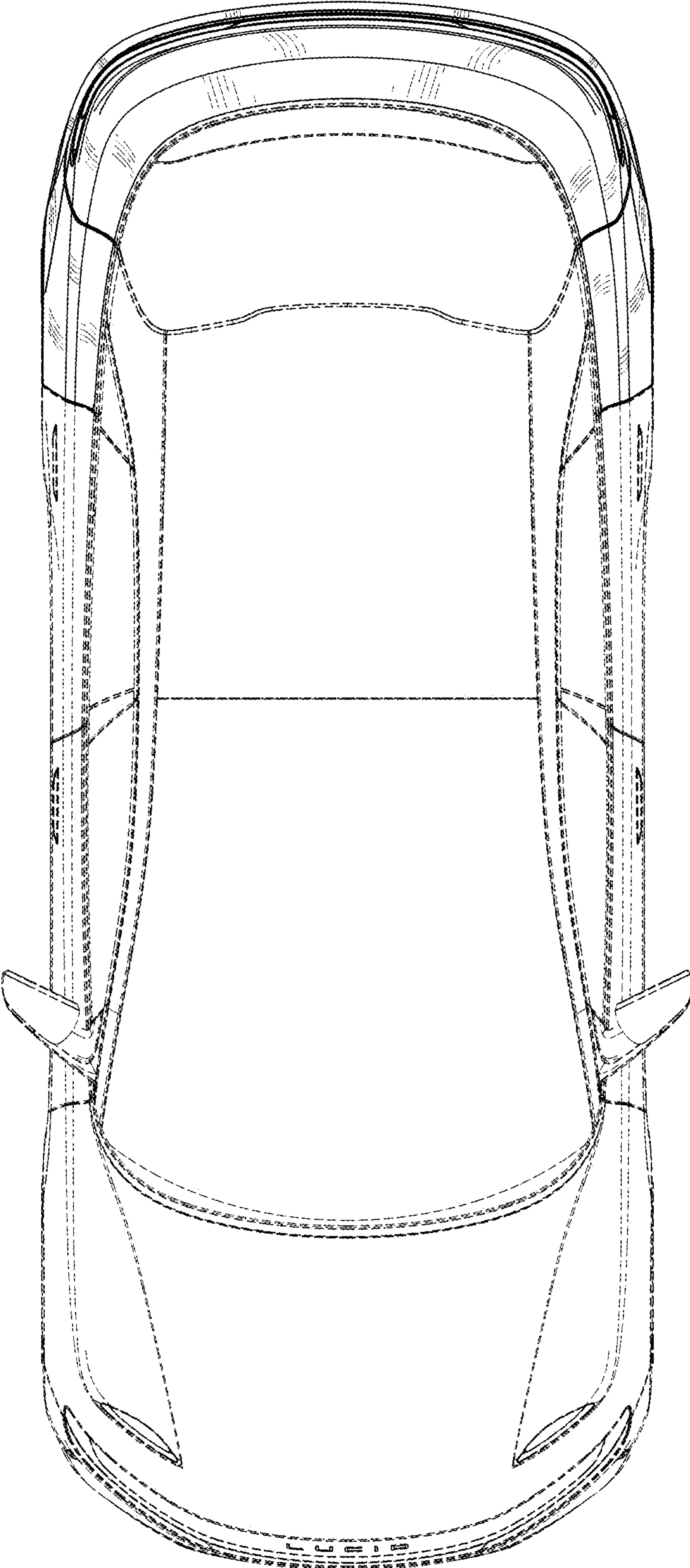

FIG - 6

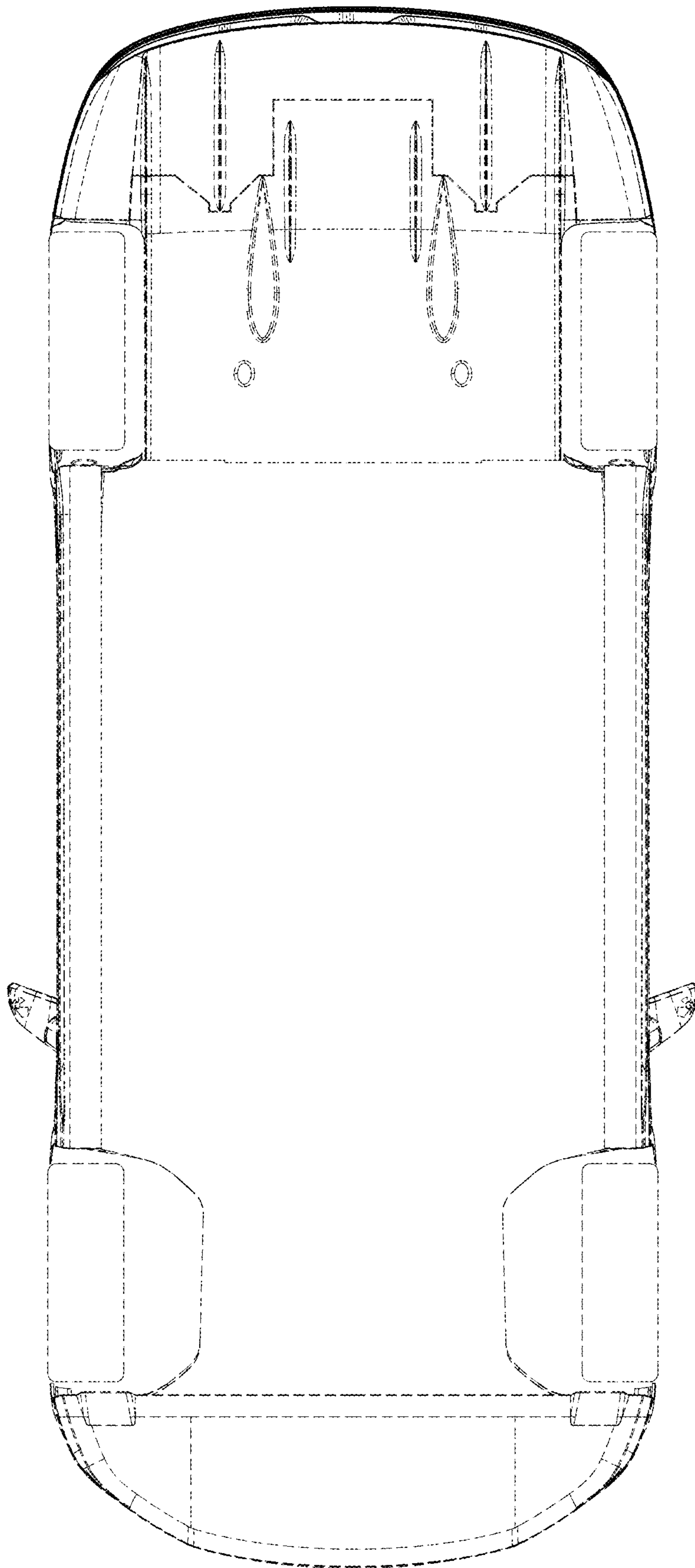

FIG-7

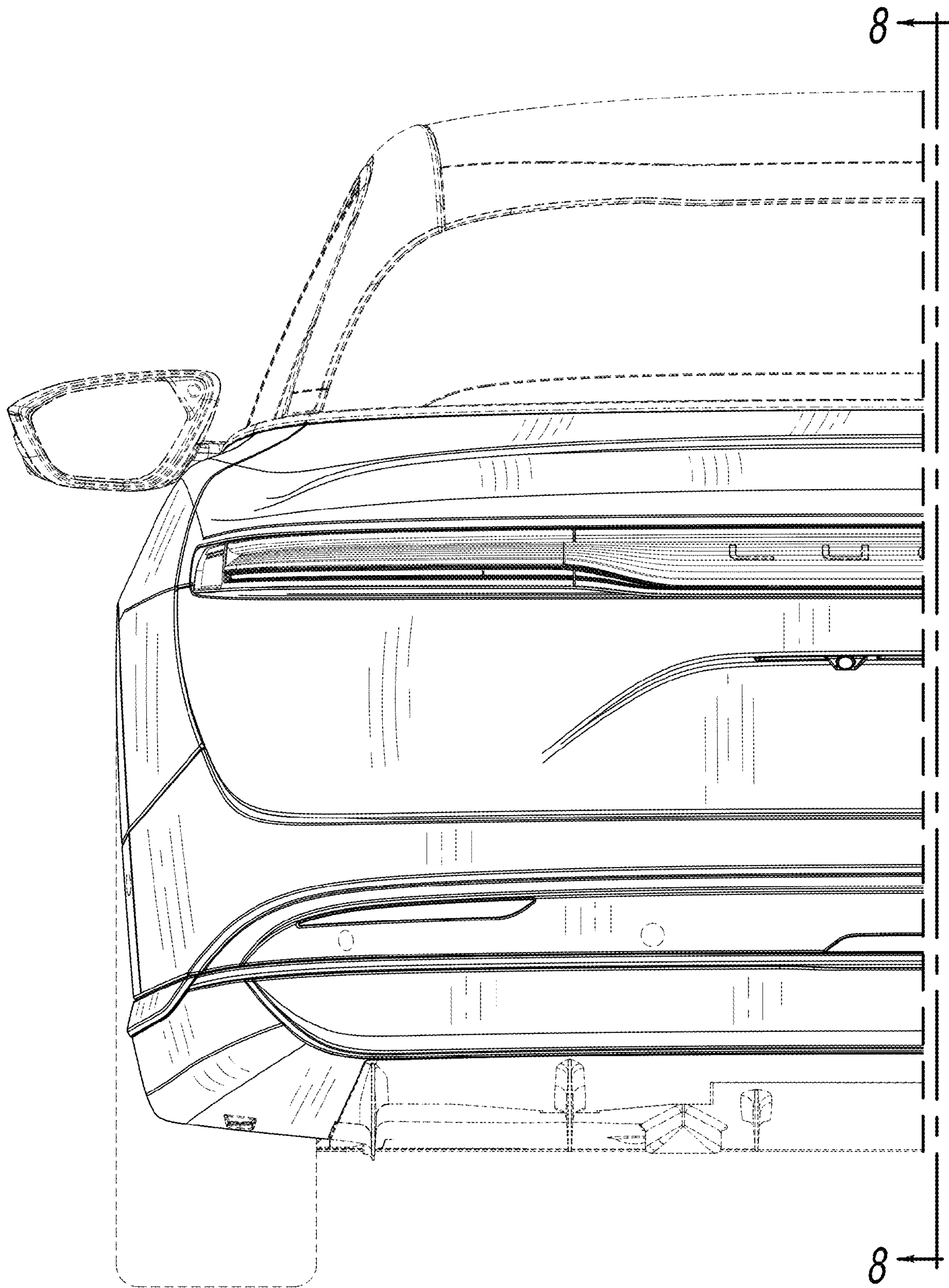

FIG - 8