



US00D966959S

(12) **United States Design Patent**  
**Kim et al.**

(10) **Patent No.:** **US D966,959 S**  
(45) **Date of Patent:** **\*\* Oct. 18, 2022**

(54) **FRONT PORTION OF AUTOMOTIVE VEHICLE, TOY REPLICA AND/OR OTHER REPLICA**

(71) Applicant: **Atieva Inc.**, Uglan House (KY)

(72) Inventors: **Jiyeon Kim**, Palo Alto, CA (US);  
**Derek N. Jenkins**, Malibu, CA (US)

(73) Assignee: **Atieva Inc.**, Grand Cayman (KY)

(\*\*) Term: **15 Years**

(21) Appl. No.: **29/740,897**

(22) Filed: **Jul. 8, 2020**

(51) **LOC (13) Cl.** ..... **12-16**

(52) **U.S. Cl.**  
USPC ..... **D12/164**

(58) **Field of Classification Search**  
USPC ..... D12/86, 90-92, 164; D21/433, 434,  
D21/531-535; 296/181.1-181.5, 183.1  
CPC ..... B62D 25/00; B62D 25/06; B62D 33/00;  
B62D 35/00

See application file for complete search history.

(56) **References Cited**

**U.S. PATENT DOCUMENTS**

D791,025 S	7/2017	Lee et al.	
D803,733 S *	11/2017	Cartabiano	D12/164
D804,357 S *	12/2017	Jeon	D12/91
D821,268 S *	6/2018	Kim	D12/92
D835,000 S *	12/2018	Tomasson	D12/91
D856,195 S *	8/2019	Kim	D12/92
D873,718 S *	1/2020	Sperling	D12/92
D913,849 S *	3/2021	Nurnberger	D12/91
D932,945 S *	10/2021	Ohnuma	D12/92

**OTHER PUBLICATIONS**

Photos of Lucid Motors AIR™ prototype vehicle exterior, published prior to Jun. 2019.  
Polestar 2 exterior, shown and discussed in Instagram post, published Aug. 10, 2019.  
R. Moore, Lucid Motors Air™ prototype vehicle review article, TopSpeed, published Aug. 25, 2017.

\* cited by examiner

*Primary Examiner* — Melody N Brown

(57) **CLAIM**

The ornamental design for a front portion of an automotive vehicle, toy replica and/or other replica.

**DESCRIPTION**

FIG. 1 is a top, front and side perspective view of a front portion of an automotive vehicle body, toy replica and/or other replica showing our new design;  
FIG. 2 is a rear elevational view thereof;  
FIG. 3 is a front elevational view thereof;  
FIG. 4 is a side elevational view thereof;  
FIG. 5 is an opposite side elevational view thereof;  
FIG. 6 is a top plan view thereof;  
FIG. 7 is a bottom plan view thereof; and,  
FIG. 8 is an enlarged fragmentary front elevational view thereof, taken along line 8-8 in FIG. 3.

The portions of the automobile vehicle and the trademark "LUCID" shown in broken lines throughout the drawing views are for illustrative and environmental purposes and form no part of the claimed design.

**1 Claim, 7 Drawing Sheets**

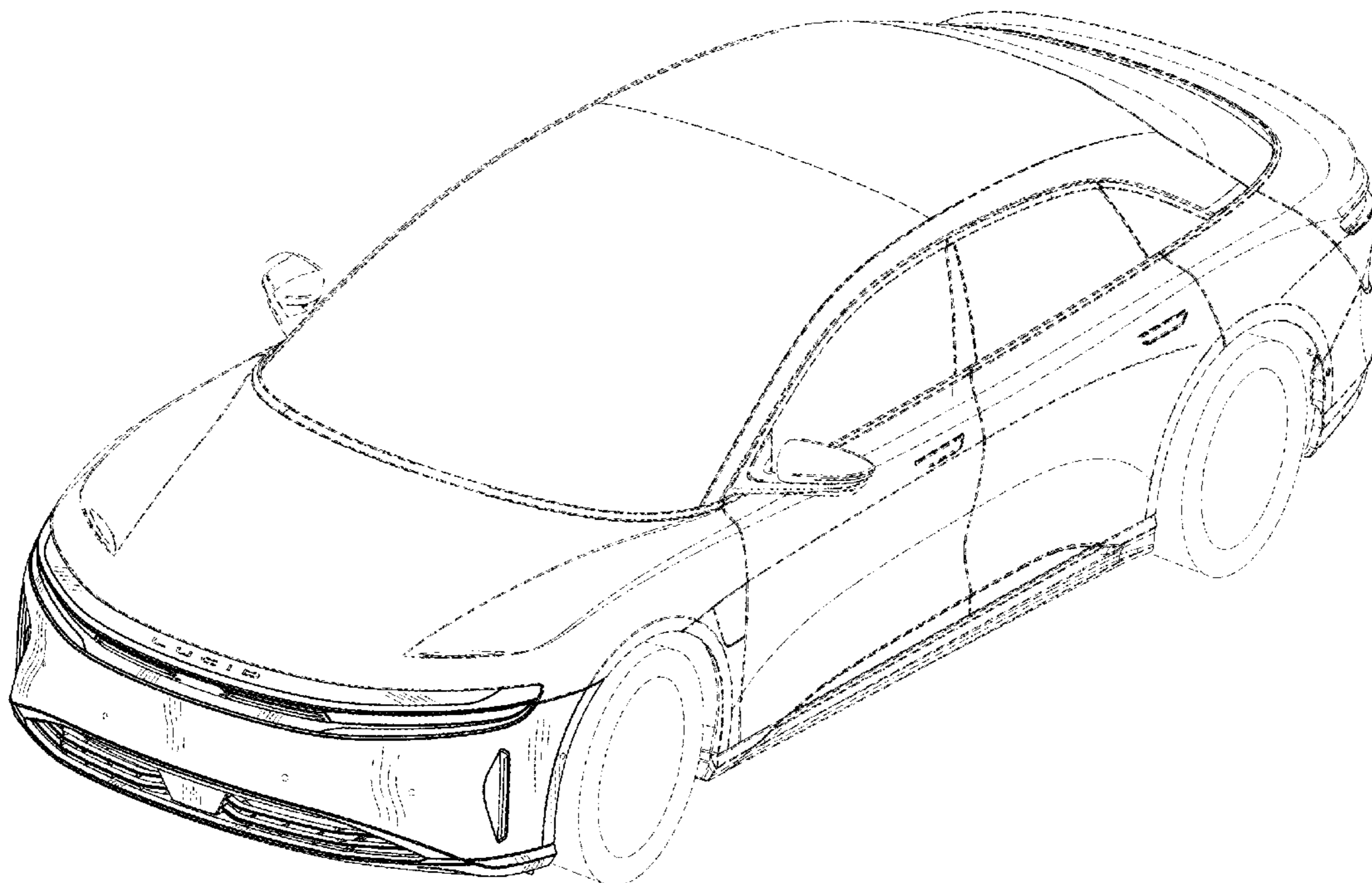

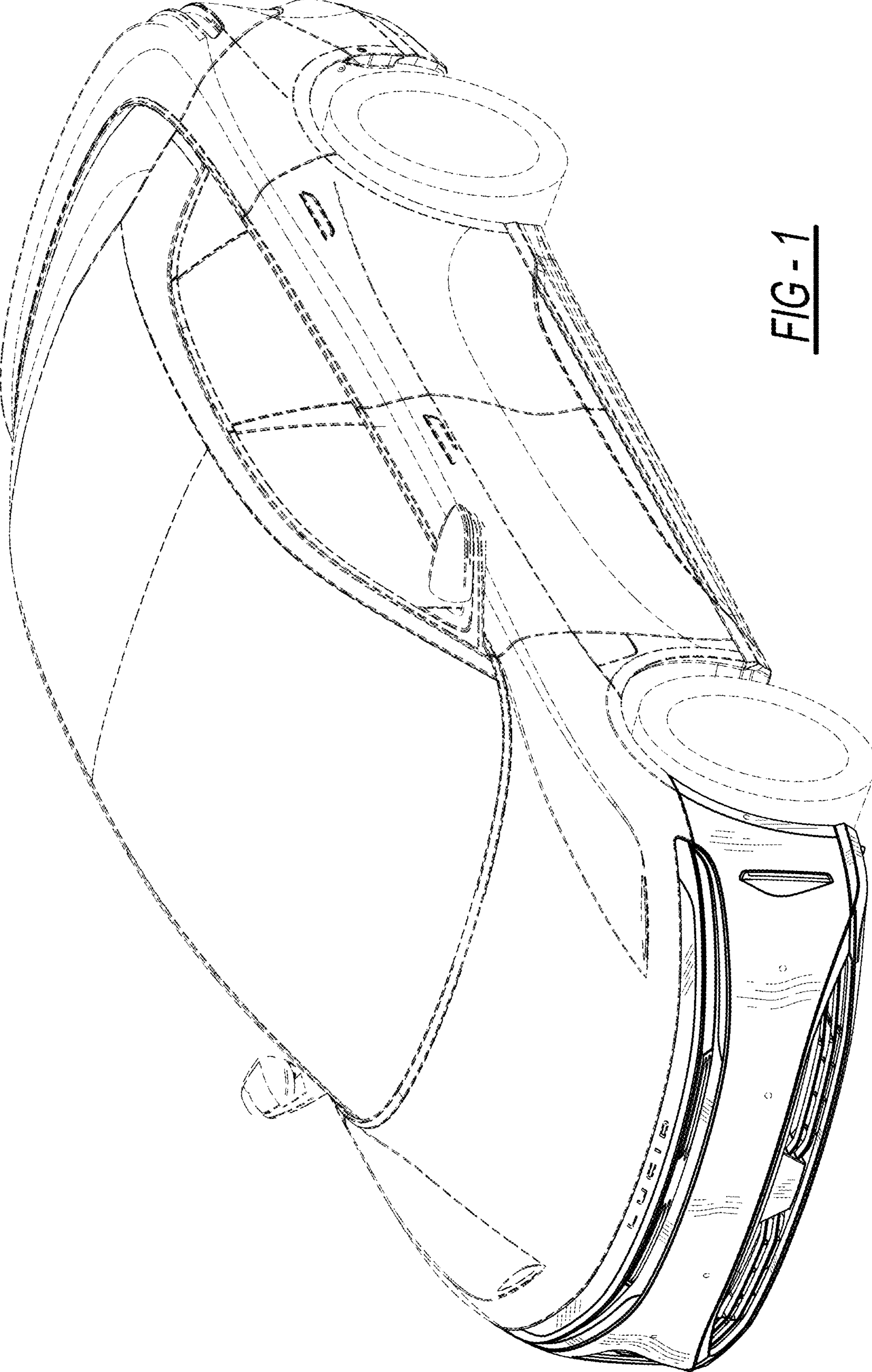

FIG - 1

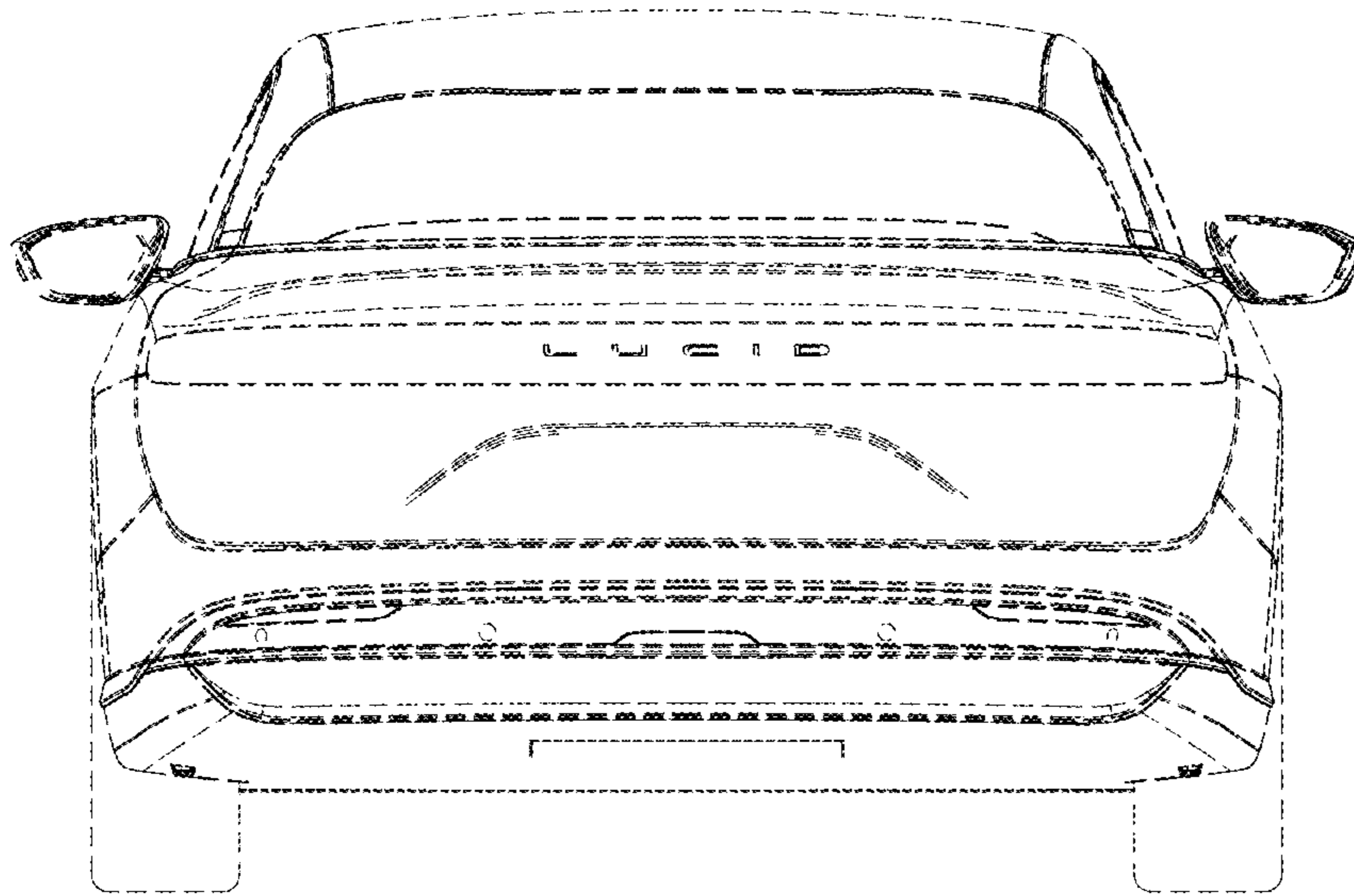

FIG - 2

8 ← |

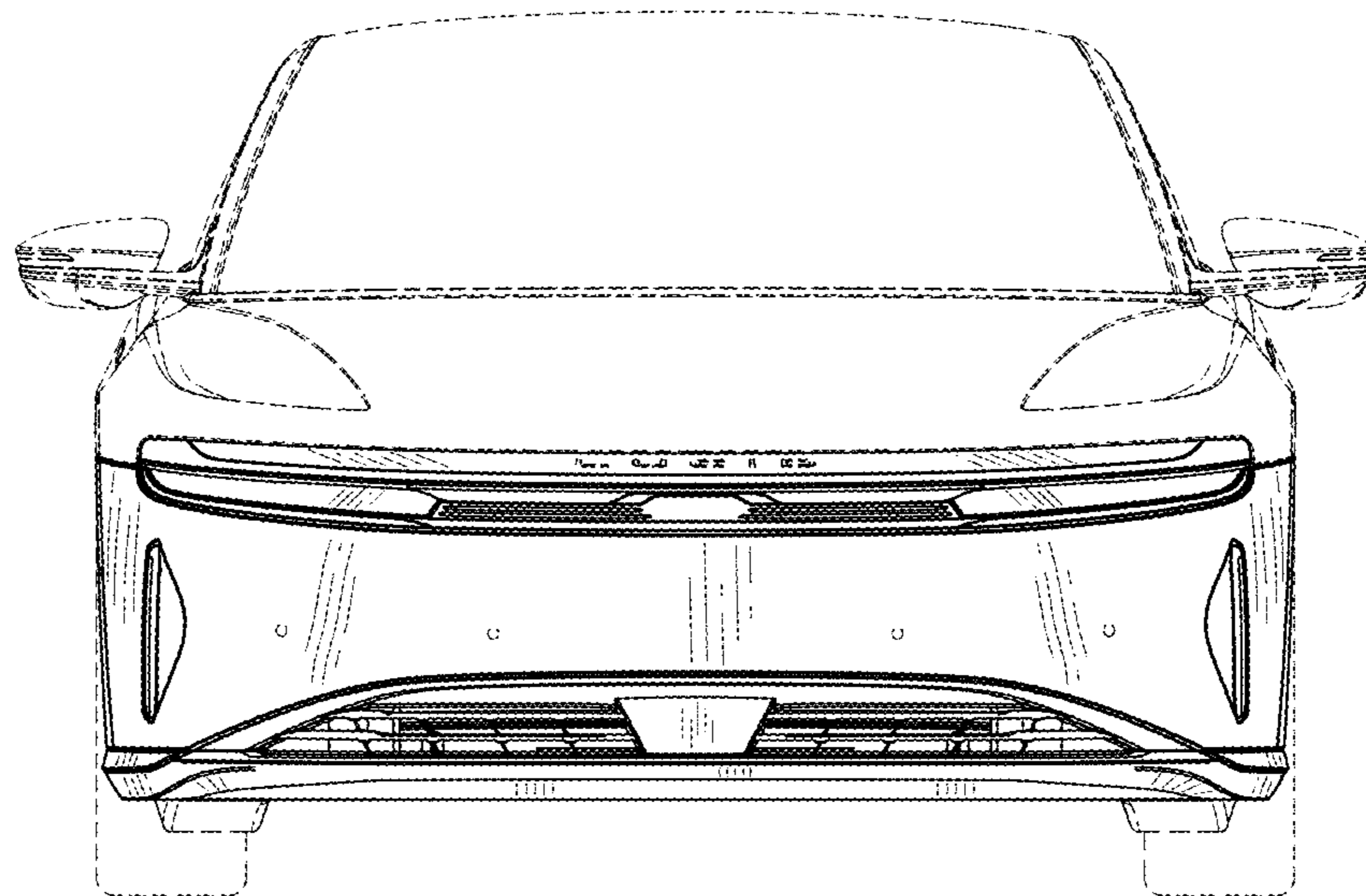

FIG - 3

8 ← |

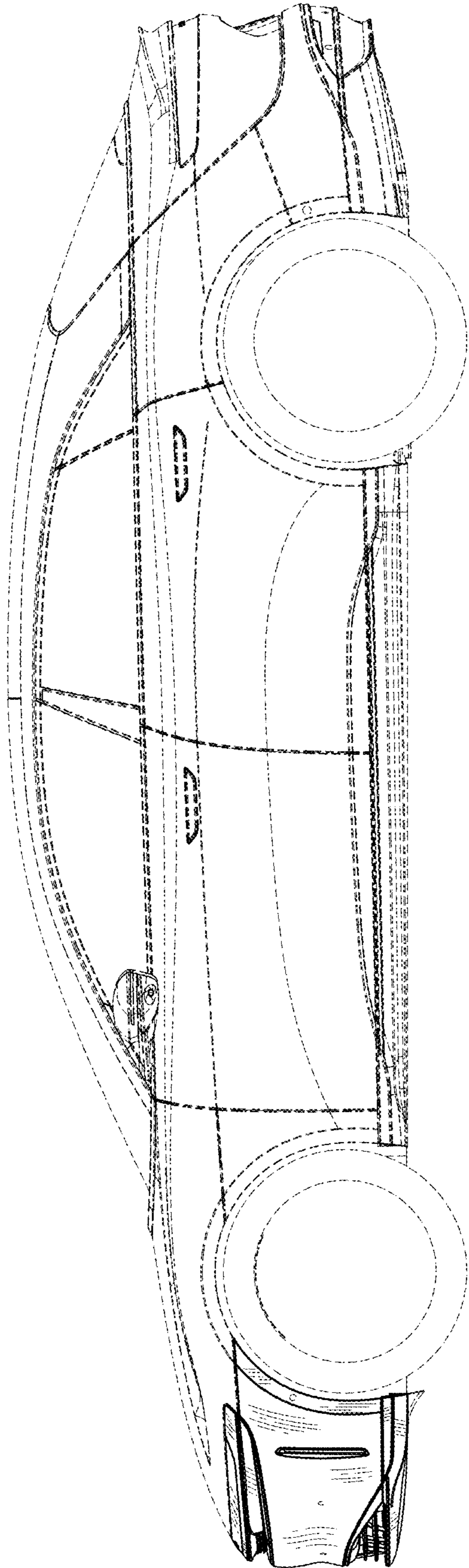

FIG - 4

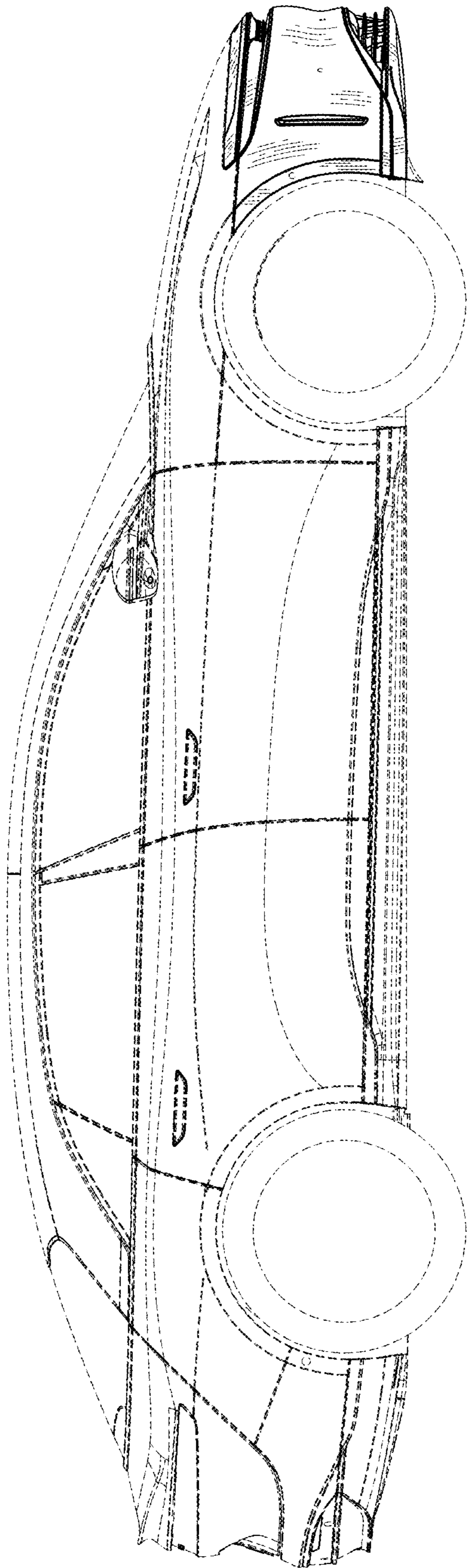

FIG - 5

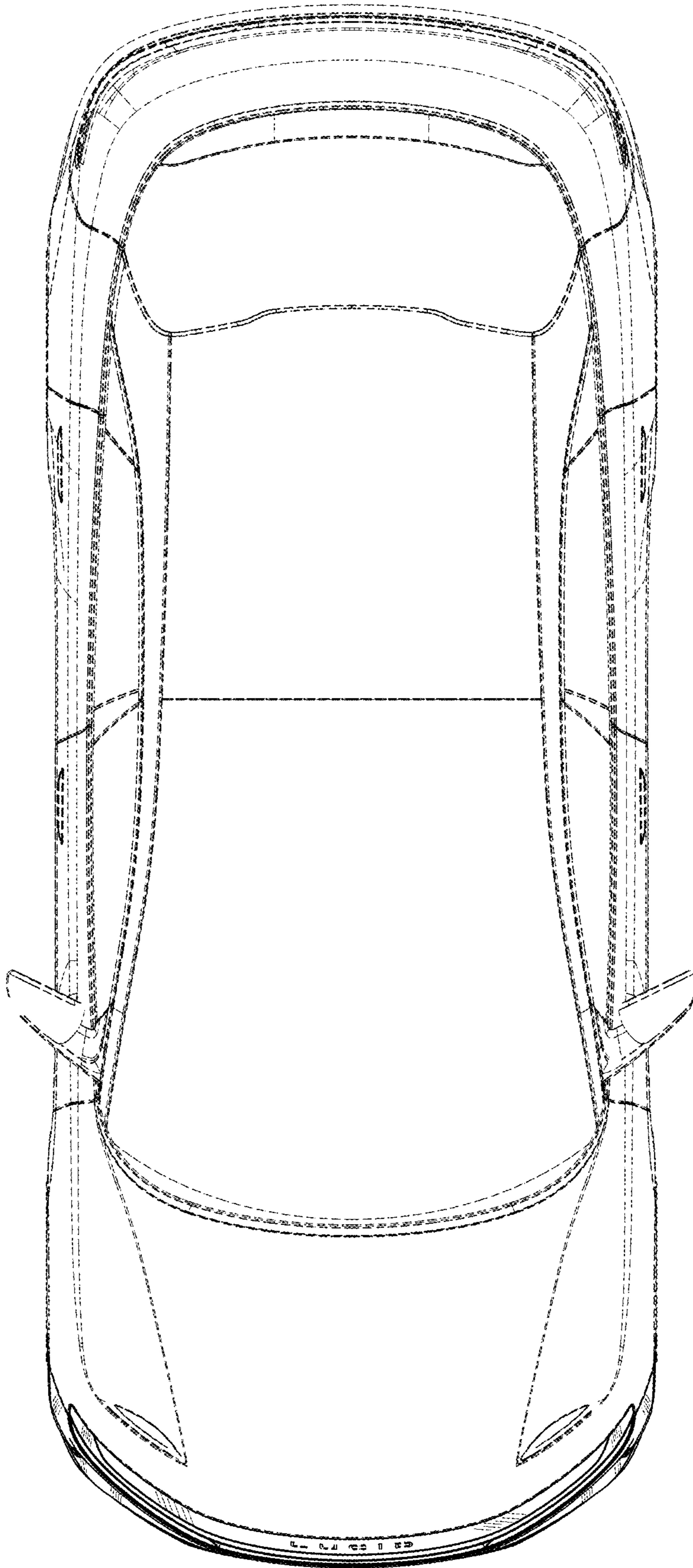

FIG - 6

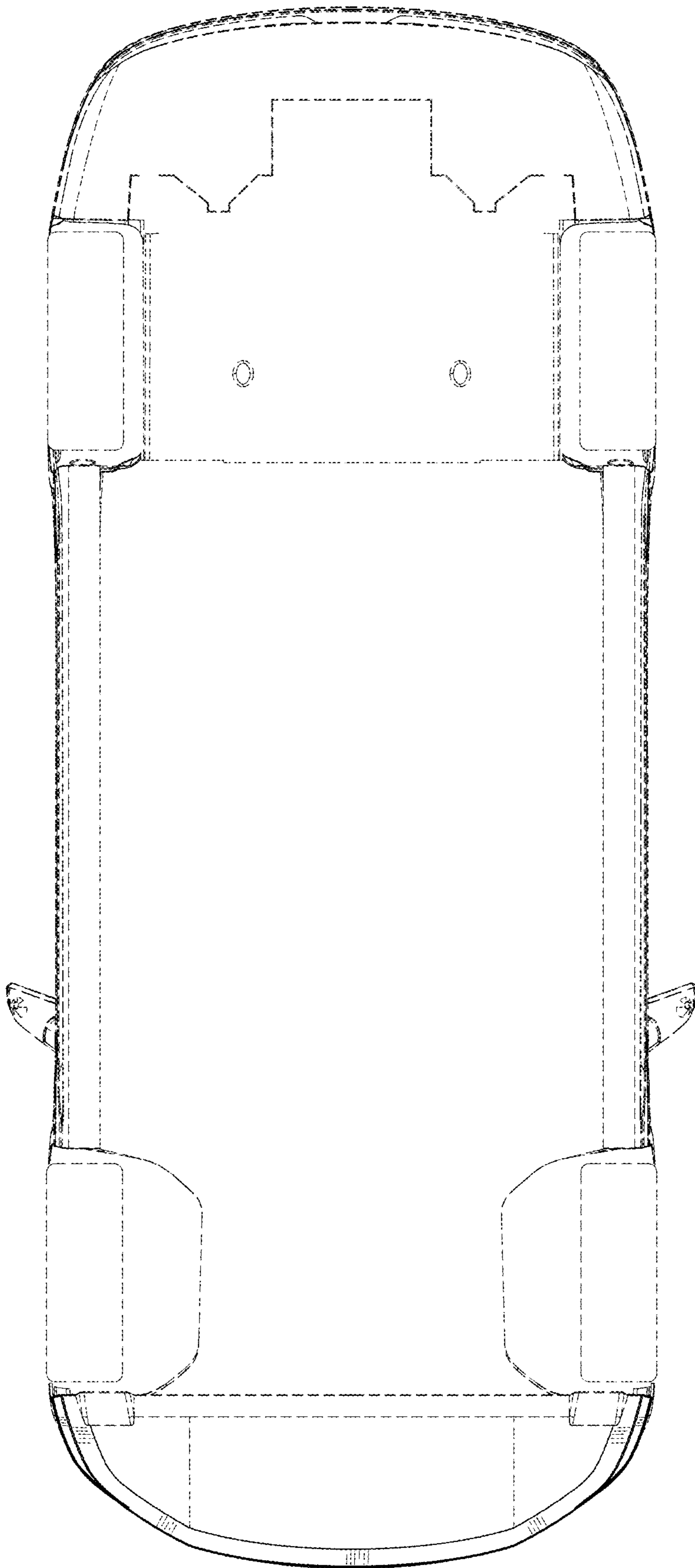

FIG-7

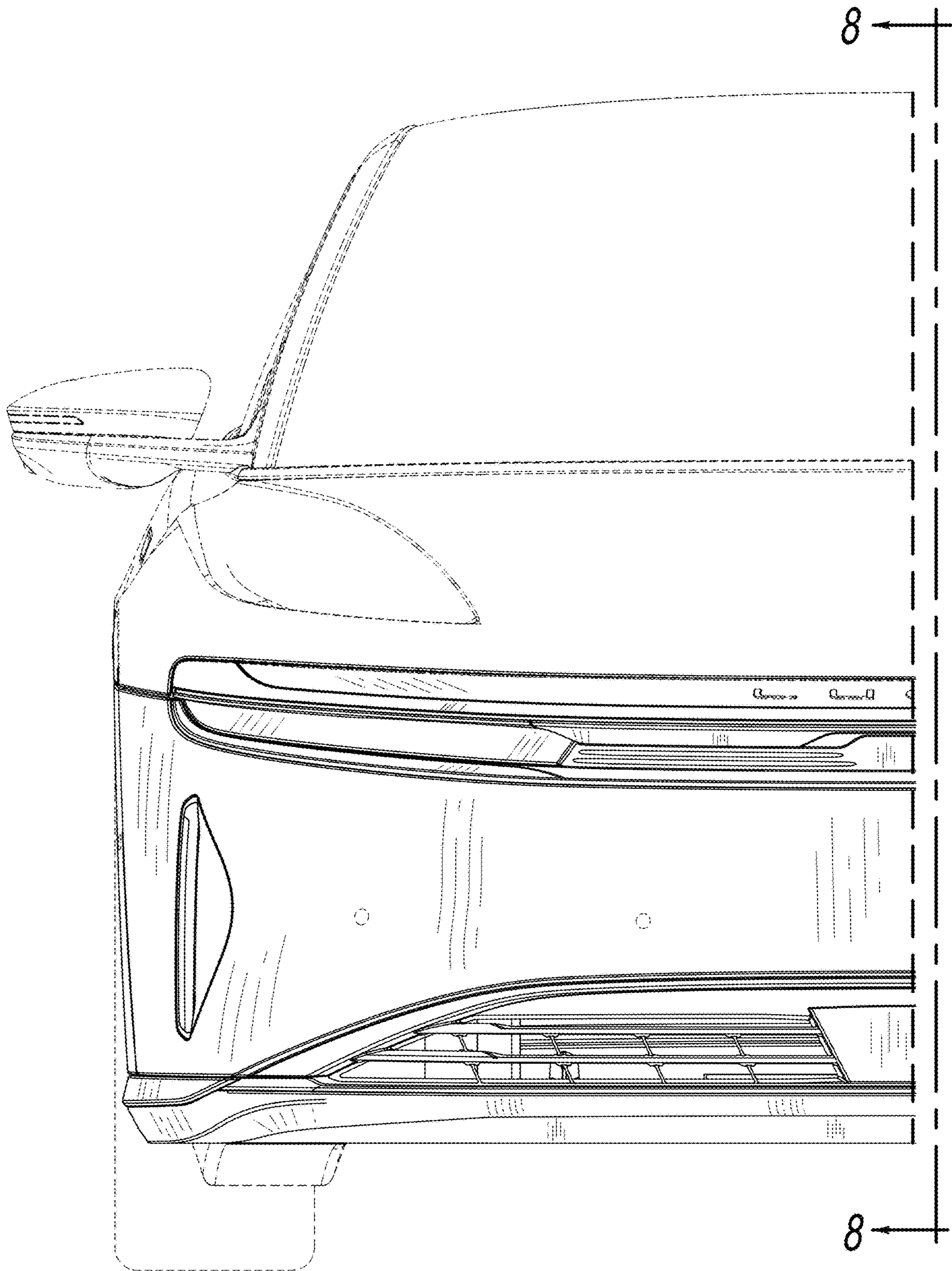

FIG - 8