



US00D966950S

(12) **United States Design Patent**
Wettig

(10) **Patent No.:** **US D966,950 S**

(45) **Date of Patent:** **** Oct. 18, 2022**

(54) **SUPPORT BAR FOR AUTOMOTIVE APPLICATIONS**

(71) Applicant: **Resource Intl Inc.**, New Castle, DE (US)

(72) Inventor: **Jason Wettig**, Abingdon, MD (US)

(73) Assignee: **Resource Intl Inc.**, New Castle, DE (US)

(**) Term: **15 Years**

(21) Appl. No.: **29/712,544**

(22) Filed: **Nov. 8, 2019**

(51) **LOC (13) Cl.** **12-16**

(52) **U.S. Cl.**
USPC **D12/159**

(58) **Field of Classification Search**
USPC D12/159, 160, 170, 171, 172
CPC .. B62D 25/084; B62D 21/152; B62D 25/082;
B62D 21/155; B62D 25/12; B62D
25/085; B62D 21/03
See application file for complete search history.

(56) **References Cited**

U.S. PATENT DOCUMENTS

6,168,226 B1 * 1/2001 Wycech B60K 17/22
296/187.02
2014/0192549 A1 * 7/2014 Townson B62D 25/085
29/466

2016/0280060 A1 * 9/2016 Sullivan B60K 11/04
2017/0129325 A1 * 5/2017 Kaneko B62D 25/084
2021/0031616 A1 * 2/2021 Glickman B60K 11/04
2022/0126921 A1 * 4/2022 Yong B62D 21/15
2022/0212724 A1 * 7/2022 Kwak B62D 25/084

FOREIGN PATENT DOCUMENTS

CN 111703508 A * 6/2019 B60K 11/04
CN 111703508 A * 9/2020 B60Q 1/02

* cited by examiner

Primary Examiner — Michael A. Pratt

(74) *Attorney, Agent, or Firm* — Condo Roccia Koptiw LLP

(57) **CLAIM**

The ornamental design for a support bar for automotive applications, as shown and described.

DESCRIPTION

FIG. 1 is a front elevation view of a support bar for automotive applications showing my new design;
FIG. 2 is a rear elevation view thereof;
FIG. 3 is a left side elevation view thereof;
FIG. 4 is a right side elevation view thereof;
FIG. 5 is a top plan view thereof;
FIG. 6 is a bottom plan view thereof; and,
FIG. 7 is a perspective view thereof.

1 Claim, 4 Drawing Sheets

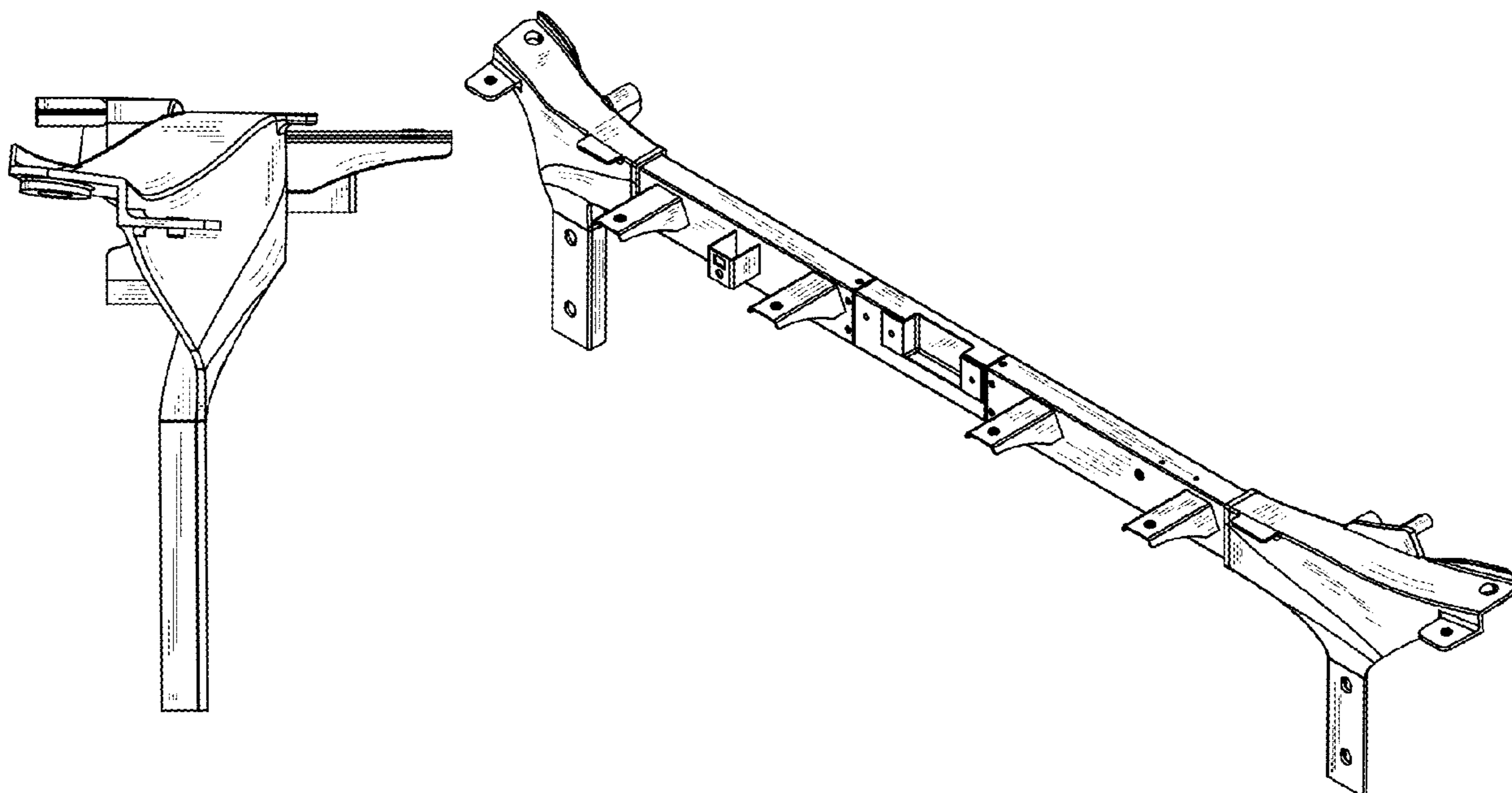

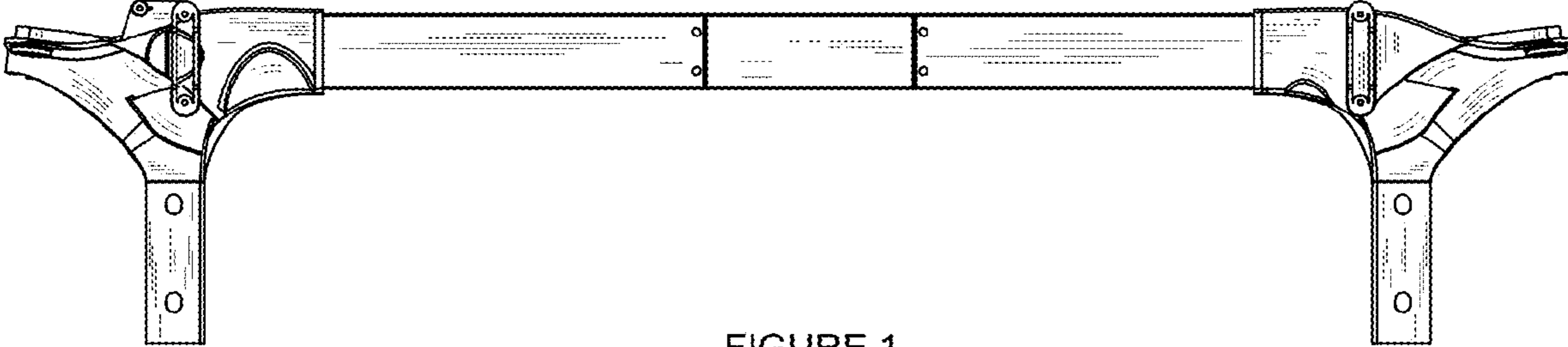

FIGURE 1

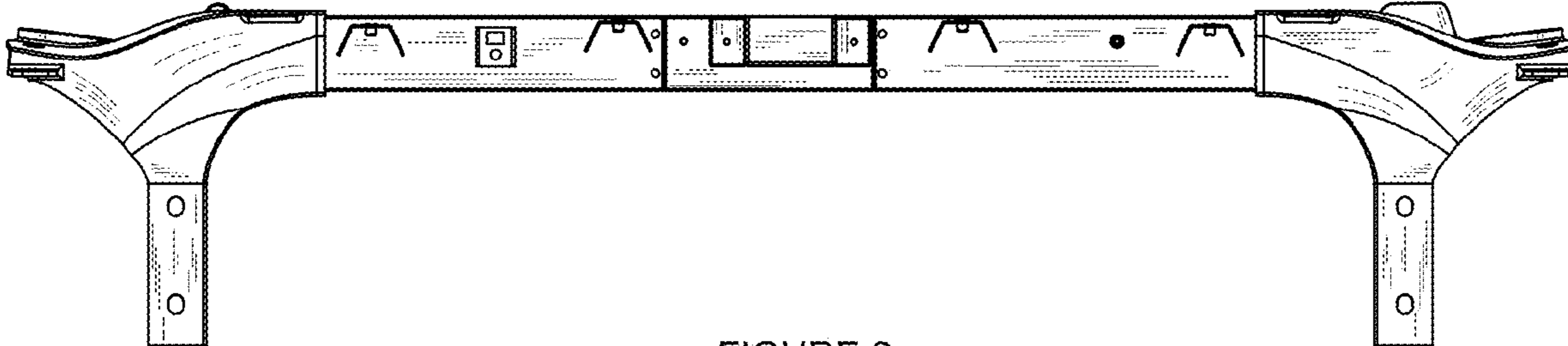

FIGURE 2

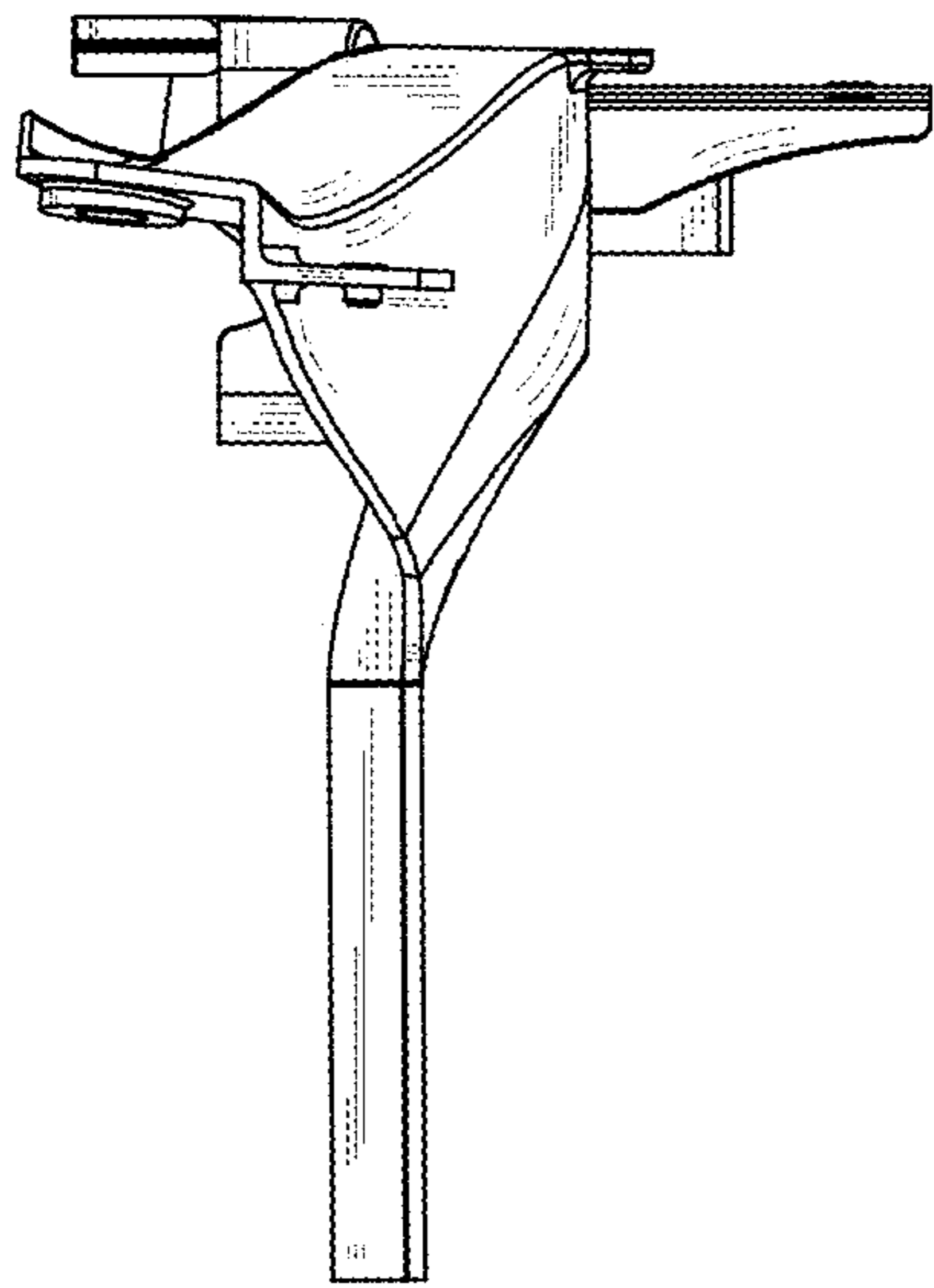

FIGURE 3

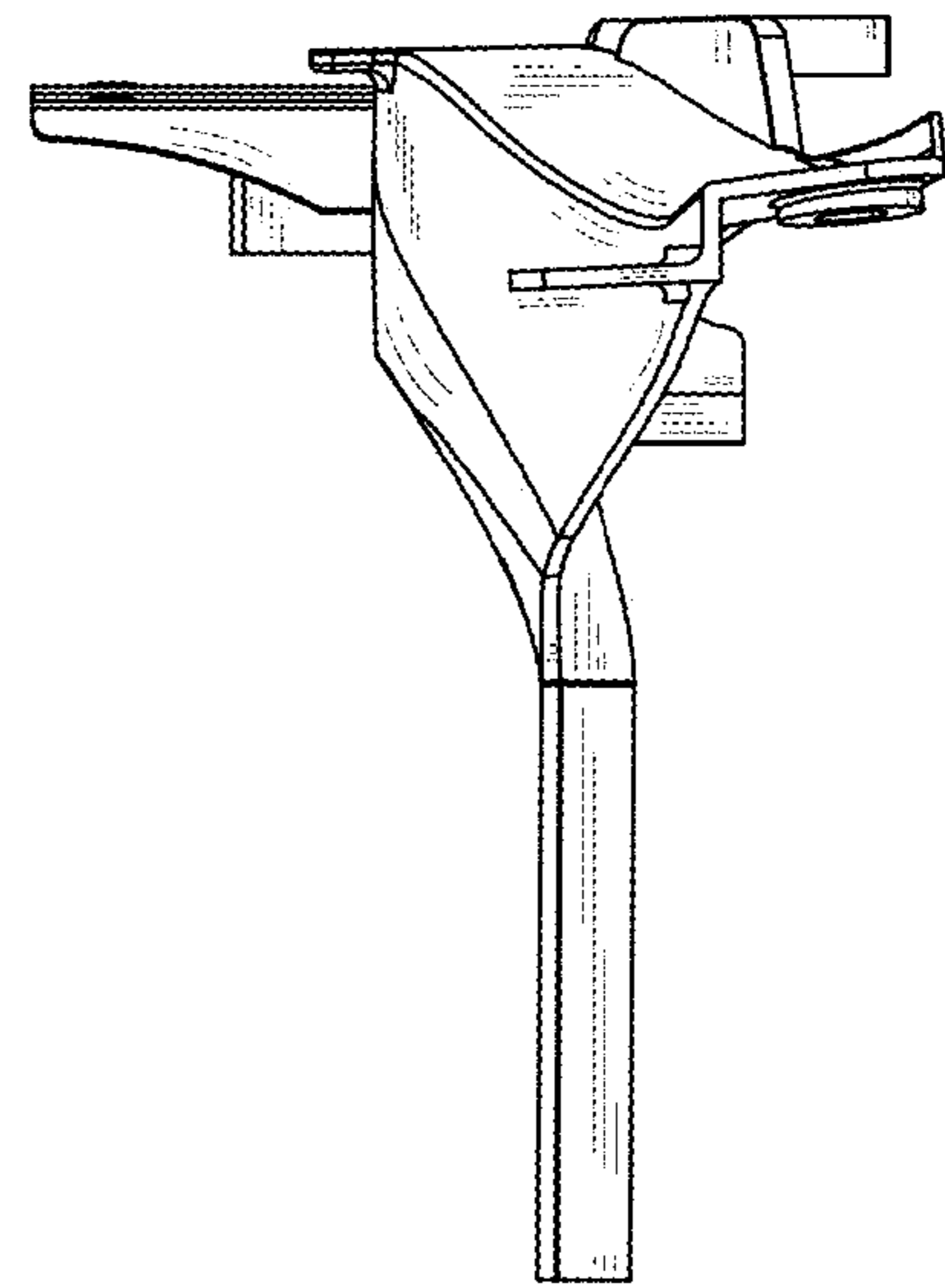

FIGURE 4

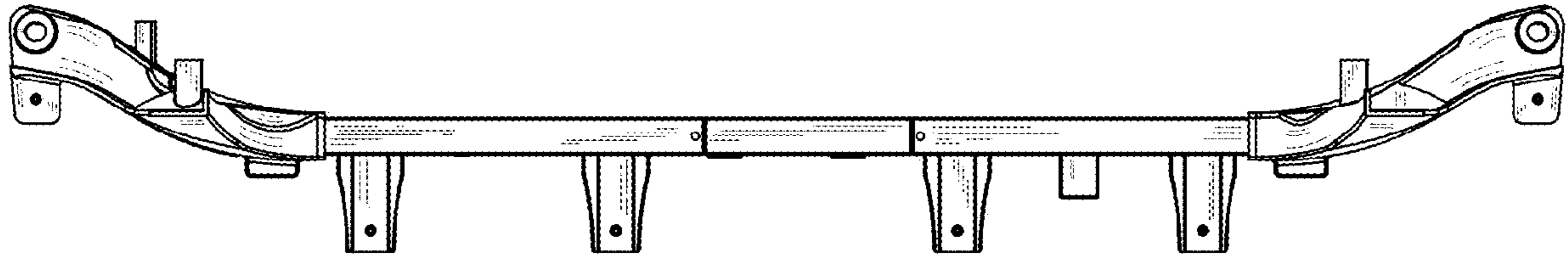

FIGURE 5

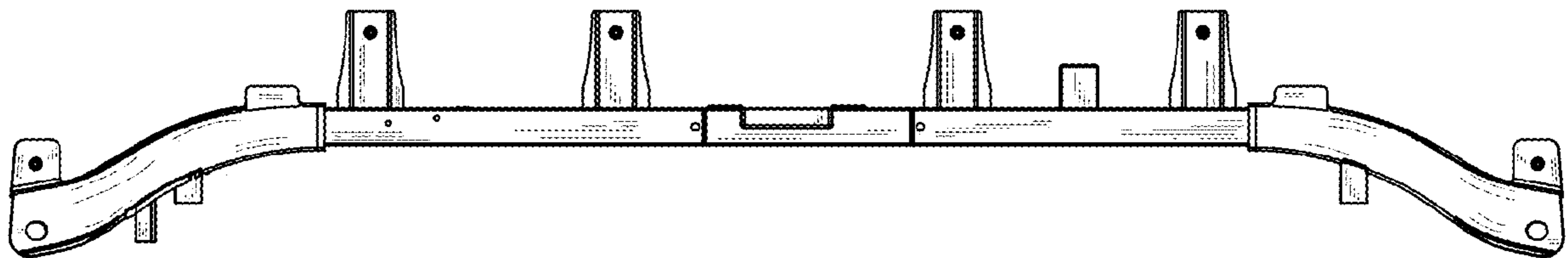

FIGURE 6

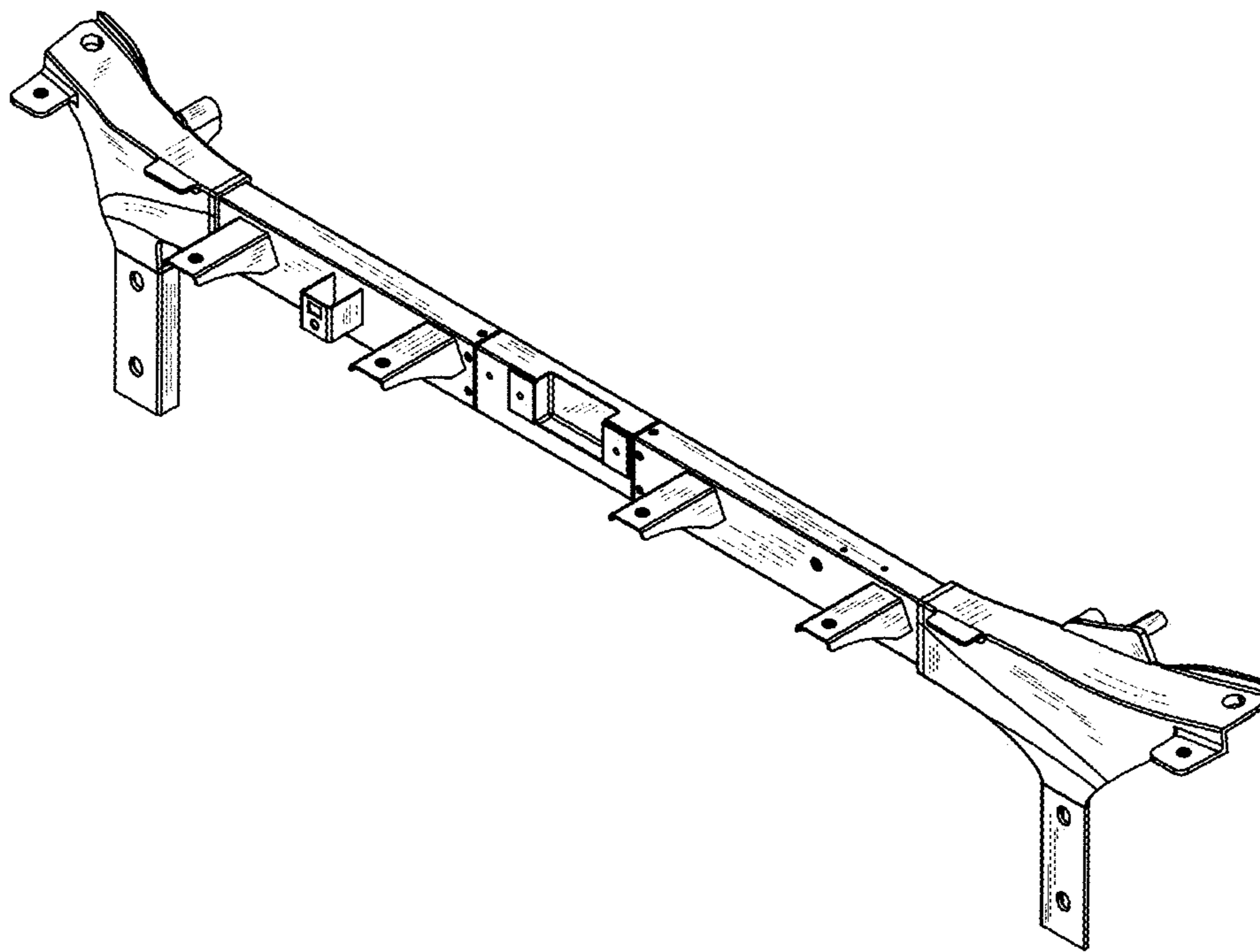

FIGURE 7