



US00D966844S

(12) **United States Design Patent** (10) **Patent No.:** **US D966,844 S**  
**Amash et al.** (45) **Date of Patent:** **\*\* Oct. 18, 2022**

(54) **FOLDING RATCHET**

(71) Applicant: **Tekton, Inc.**, Grand Rapids, MI (US)

(72) Inventors: **John A. Amash**, Grand Rapids, MI (US); **Joshua L. Harrison**, Grand Rapids, MI (US); **Kramer A. Doyle**, Saugatuck, MI (US)

(73) Assignee: **Tekton, Inc.**, Grand Rapids, MI (US)

(\*\*) Term: **15 Years**

(21) Appl. No.: **29/769,298**

(22) Filed: **Feb. 4, 2021**

(51) **LOC (13) Cl.** ..... **08-05**

(52) **U.S. Cl.**  
USPC ..... **D8/25**

(58) **Field of Classification Search**  
USPC ..... D8/14, 21, 24-27, 29, 51, 59, 107;  
D24/133, 147; 81/57.13, 57.39, 60  
CPC ..... B25B 21/004; B25B 13/46; B25B 13/463  
See application file for complete search history.

(56) **References Cited**

**U.S. PATENT DOCUMENTS**

5,280,740	A	1/1994	Ernst	
5,331,869	A	7/1994	Webb	
5,542,322	A	8/1996	Knox et al.	
D419,837	S *	2/2000	Knox	B25B 13/461 D8/25
6,286,395	B1 *	9/2001	Frazier	B25G 1/105 81/177.2
D506,373	S *	6/2005	Hsien	B25B 23/0028 D8/27
D516,405	S *	3/2006	Saunders	D8/80
7,066,059	B1	6/2006	Hsieh	
D525,493	S *	7/2006	Hsieh	D8/27
7,168,345	B1	1/2007	Hsieh	
D562,654	S	2/2008	Yang	
D577,969	S *	10/2008	Yang	D8/27
D649,848	S *	12/2011	Wegerich	D8/25
D654,337	S *	2/2012	Huang	D8/25
D658,460	S *	5/2012	Wang	D8/25
D663,177	S *	7/2012	Chen	D8/25

(Continued)

**OTHER PUBLICATIONS**

“Here’s the New Tekton Folding Ratchet”; Stuart; ToolGuyd.com; Dec. 21, 2020; Accessed Apr. 18, 2022; URL: < https://toolguyd.com/tekton-folding-ratchet/ > (Year: 2020).\*

(Continued)

*Primary Examiner* — Rachel A. Voorhies

*Assistant Examiner* — Benjamin D. Wannemacher

(74) *Attorney, Agent, or Firm* — Warner Norcross + Judd LLP

(57) **CLAIM**

The ornamental design for a folding ratchet, as shown and described.

**DESCRIPTION**

FIG. 1 is a top, front, right perspective view of a folding ratchet embodying the new design;  
FIG. 2 is a top, rear, right perspective view thereof;  
FIG. 3 is a bottom, rear, right perspective view thereof;  
FIG. 4 is a bottom, front, right perspective view thereof;  
FIG. 5 is a top view thereof;  
FIG. 6 is a bottom view thereof;  
FIG. 7 is a right side view thereof, the left side view being a mirror image thereof;  
FIG. 8 is a front view thereof; and,  
FIG. 9 is a rear view thereof.

The dash-dash broken lines are for the purpose of illustrating portions of the folding ratchet and forms no part of the claimed design.

The dot-dash broken lines represent unclaimed boundaries and form no part of the claimed design. In FIGS. 3, 4, and 6, the region on the flat underside of the ratchet between the dot-dash broken line and the adjacent interior solid line forms no part of the claimed design.

**1 Claim, 4 Drawing Sheets**

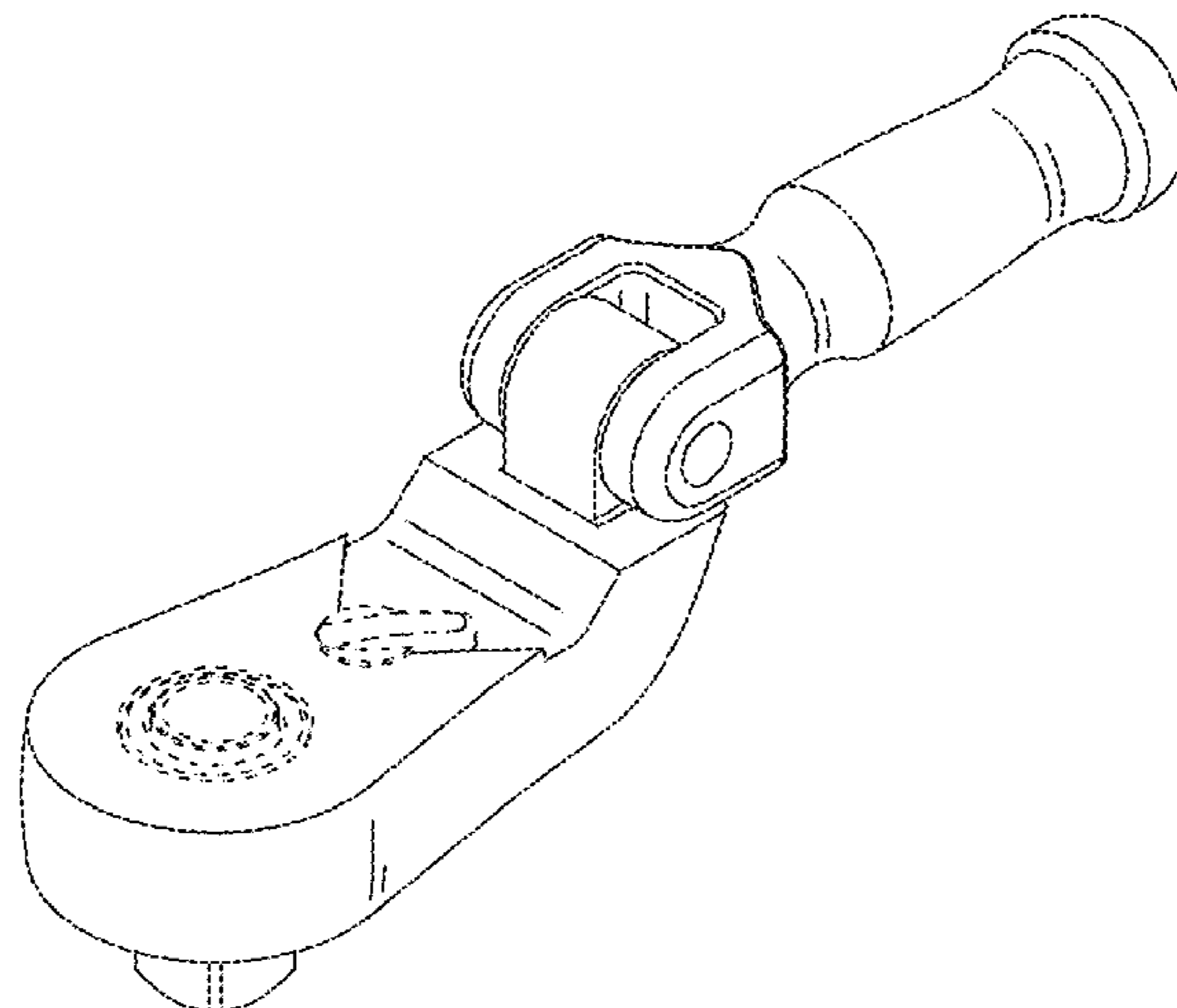

(56)

**References Cited**

U.S. PATENT DOCUMENTS

8,408,099	B2	4/2013	Liou	
8,474,353	B1	7/2013	Thoman	
8,621,963	B2	1/2014	Johnson et al.	
D724,399	S *	3/2015	Chern .....	D8/22
D786,639	S	5/2017	Tang	
9,925,654	B2	3/2018	Ragner	
2004/0139826	A1 *	7/2004	Hsien .....	B25B 13/463 81/63.2
2009/0241740	A1 *	10/2009	Heagerty .....	B25B 13/461 81/177.8
2014/0033877	A1 *	2/2014	Lee .....	B25B 23/0028 81/177.8
2020/0282532	A1 *	9/2020	Amash .....	B25B 23/0035

OTHER PUBLICATIONS

Tekton <sup>3</sup>/<sub>8</sub> Inch Drive × 8 Inch Quick-Release Ratchet, <https://www.tekton.com/quick-release-ratchets?quantity=1&drive-size=3-8-in>,

believed to be commercially available at least as early as Feb. 3, 2021.

Tekton <sup>3</sup>/<sub>8</sub> Inch Drive × 8 Inch Flex Head Quick-Release Ratchet, <https://www.tekton.com/flex-quick-release-ratchets?quantity=1&drive-size=3-8-in>, believed to be commercially available at least as early as Feb. 3, 2021.

Tekton <sup>3</sup>/<sub>8</sub> Inch Drive × 4-<sup>1</sup>/<sub>2</sub> Inch Quick-Release Ratchet, <https://www.tekton.com/stubby-quick-release-ratchets?quantity=1&drive-size=3-8-in>, believed to be commercially available at least as early as Feb. 3, 2021.

Blue-Point STABIT 2190 Wrench, images attached (date: at least as early as Mar. 4, 2019).

<https://www.tekton.com/composite-ratchets>, pp. 1-6, believed to be commercially available at least as early as Mar. 4, 2019.

<https://www.tekton.com/flex-ratchets>, pp. 1-10, believed to be commercially available at least as early as Mar. 4, 2019.

Pictures of ratchet believed to be commercially available at least as early as Mar. 4, 2019.

\* cited by examiner

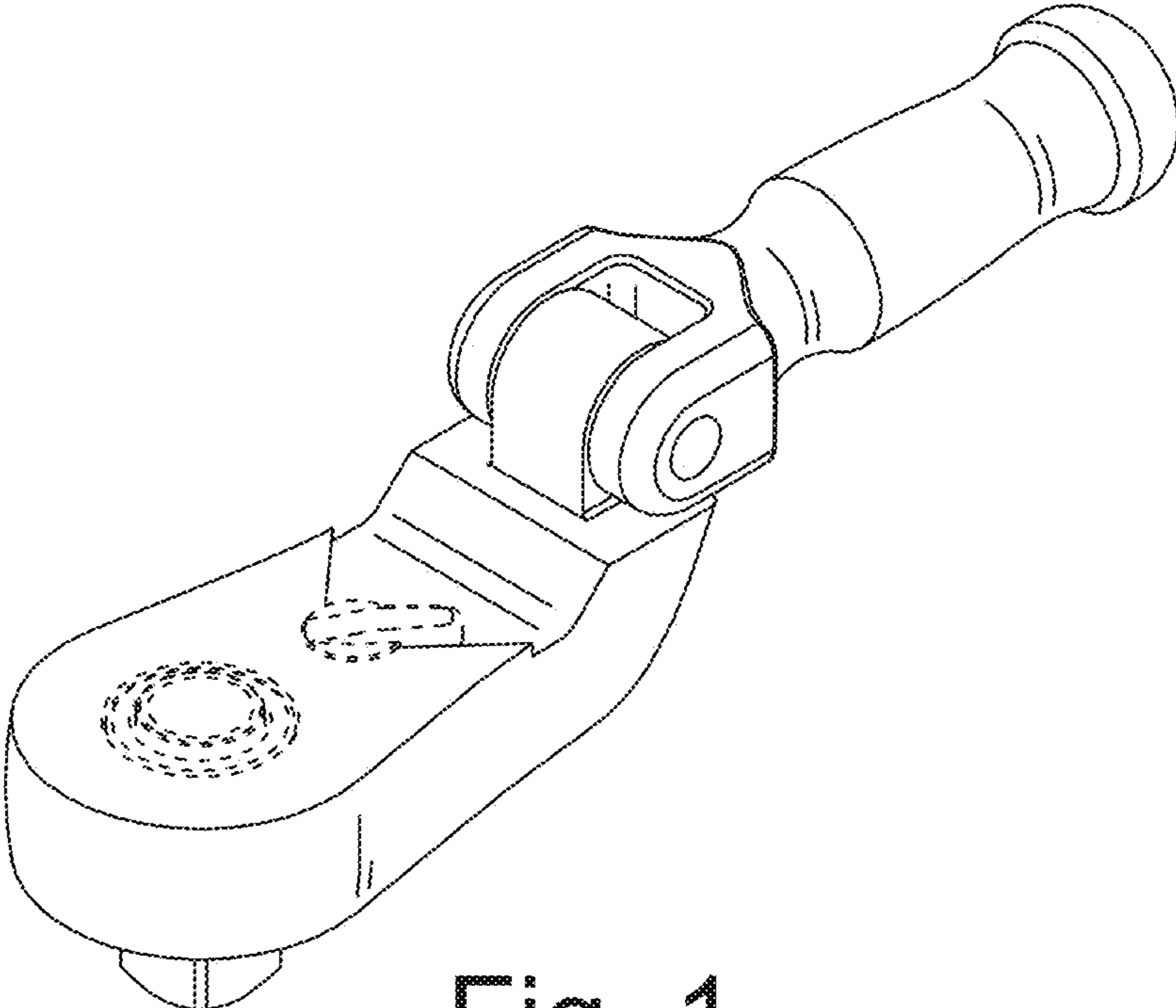

Fig. 1

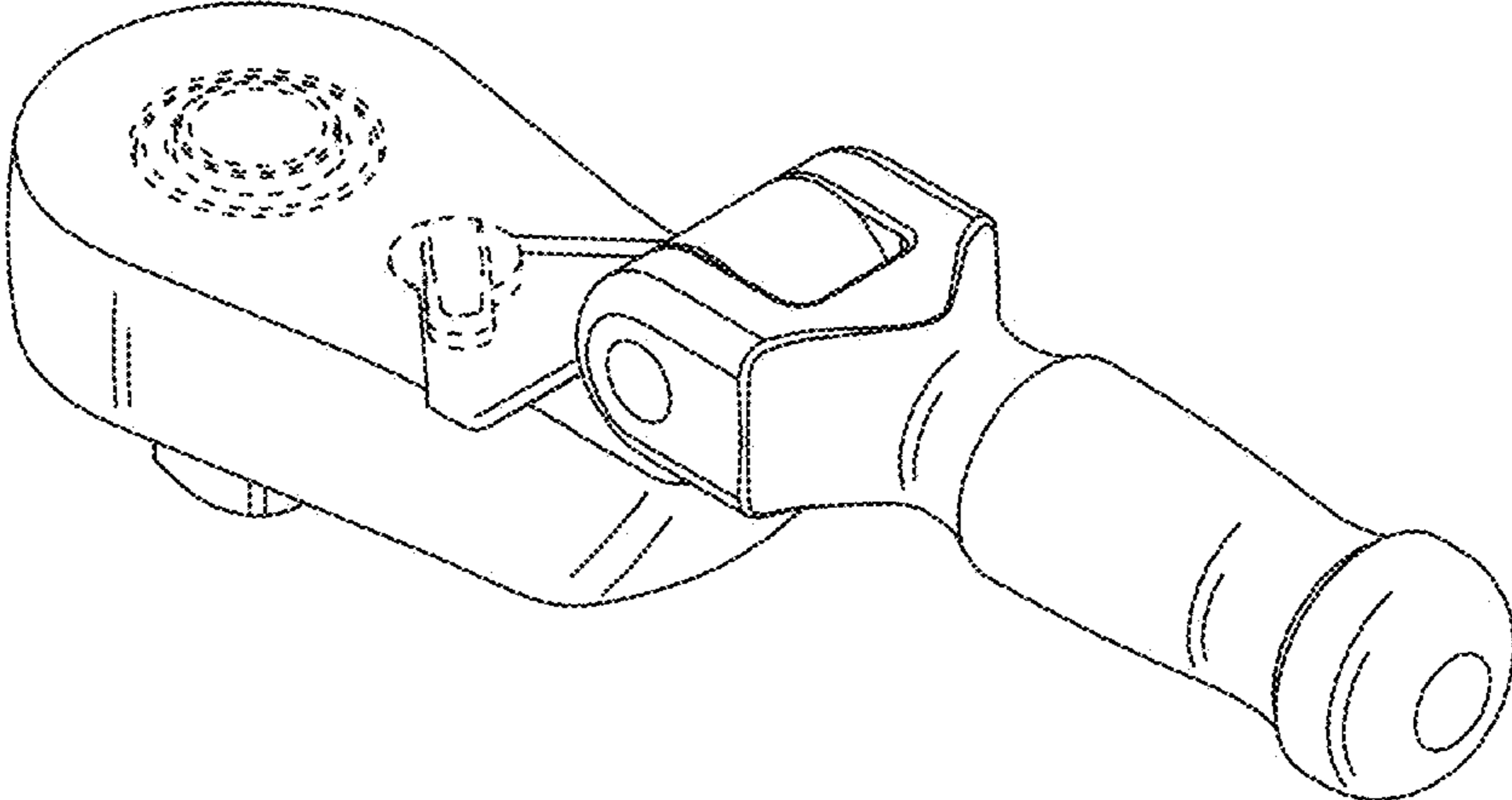

Fig. 2

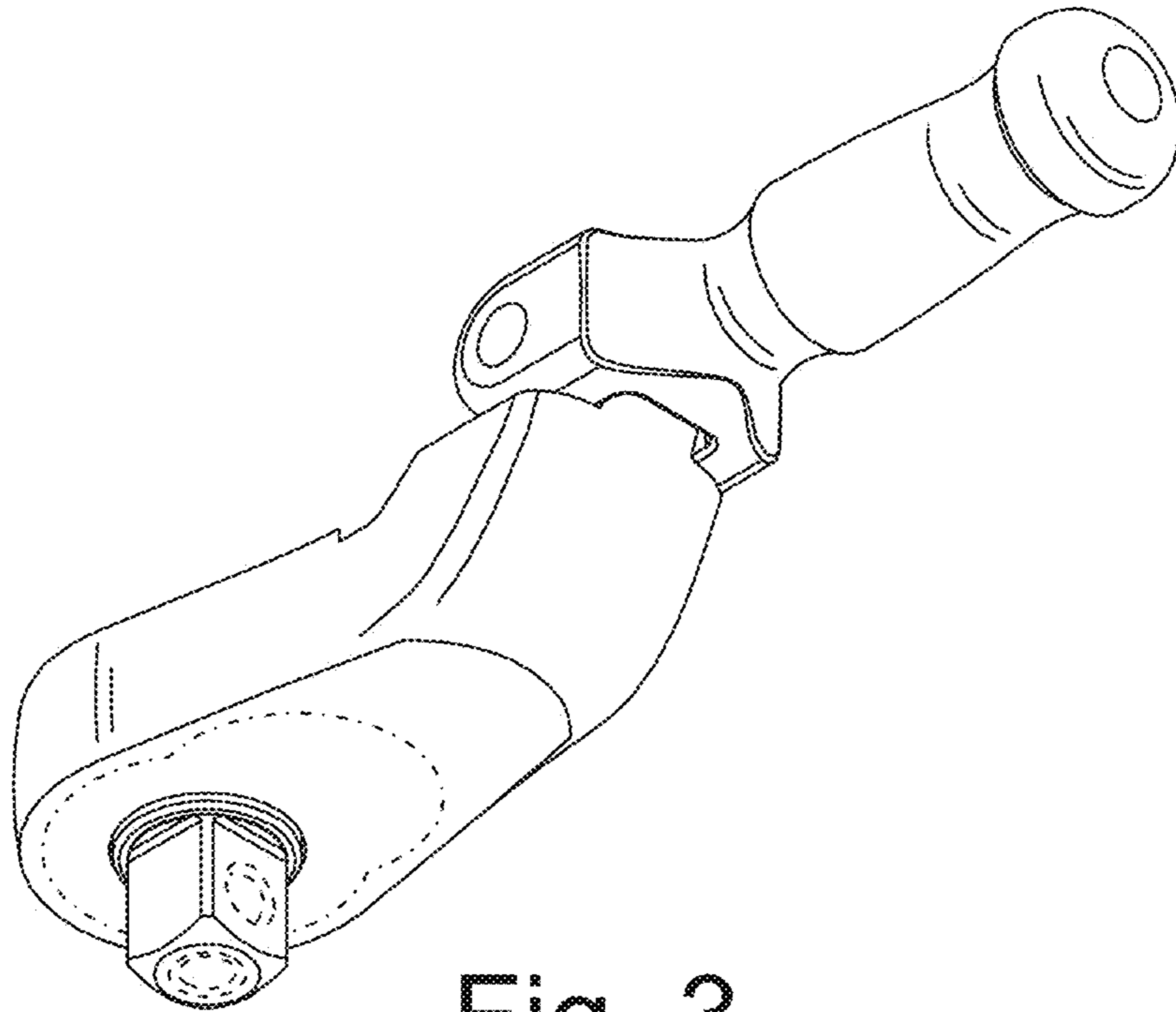

Fig. 3

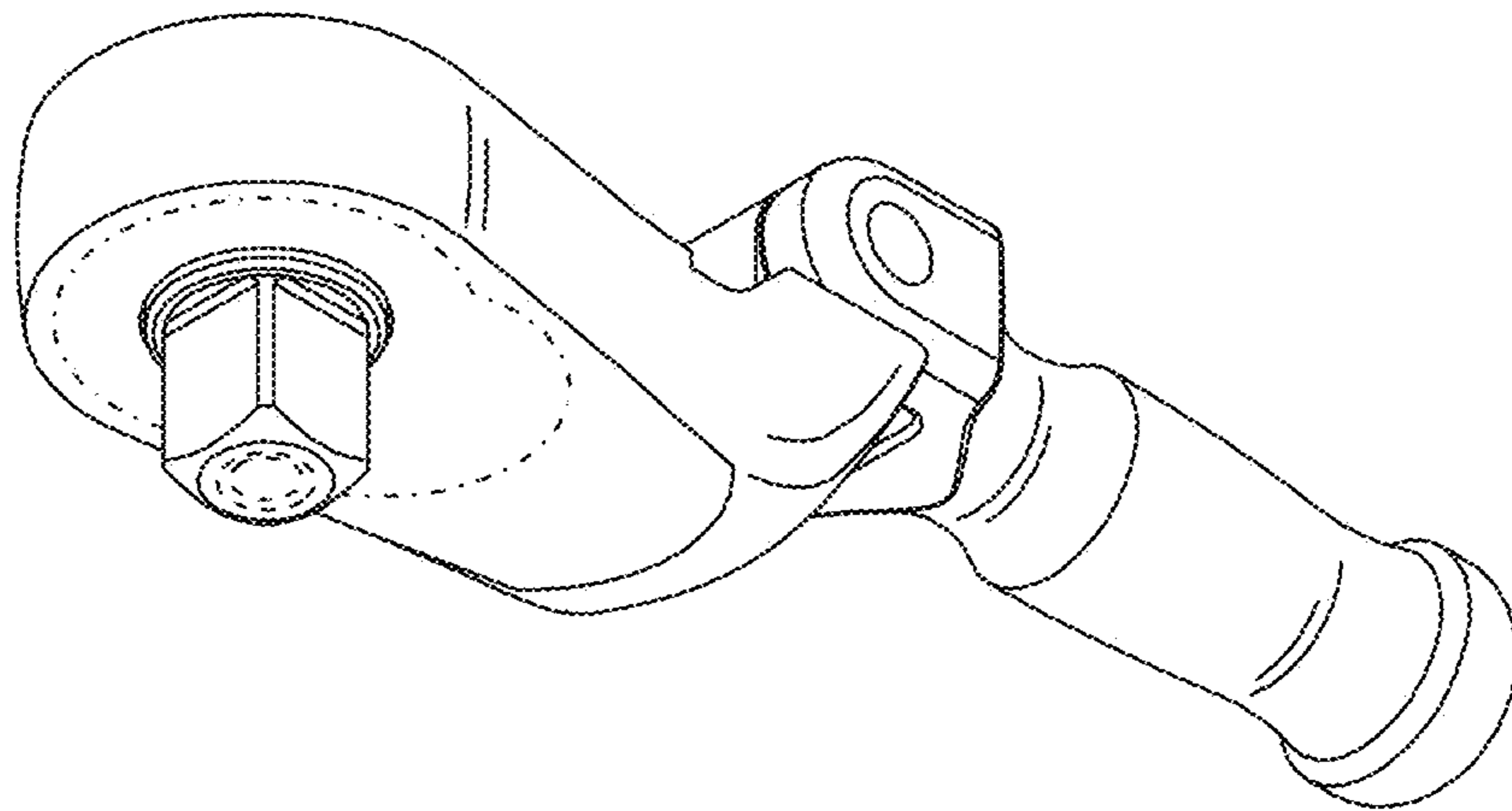

Fig. 4

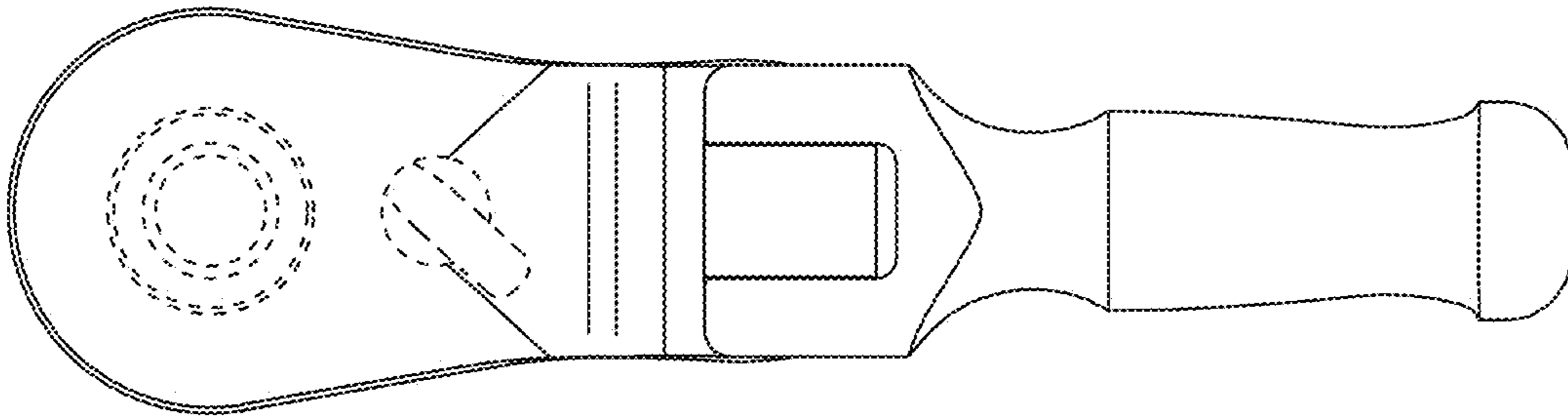

Fig. 5

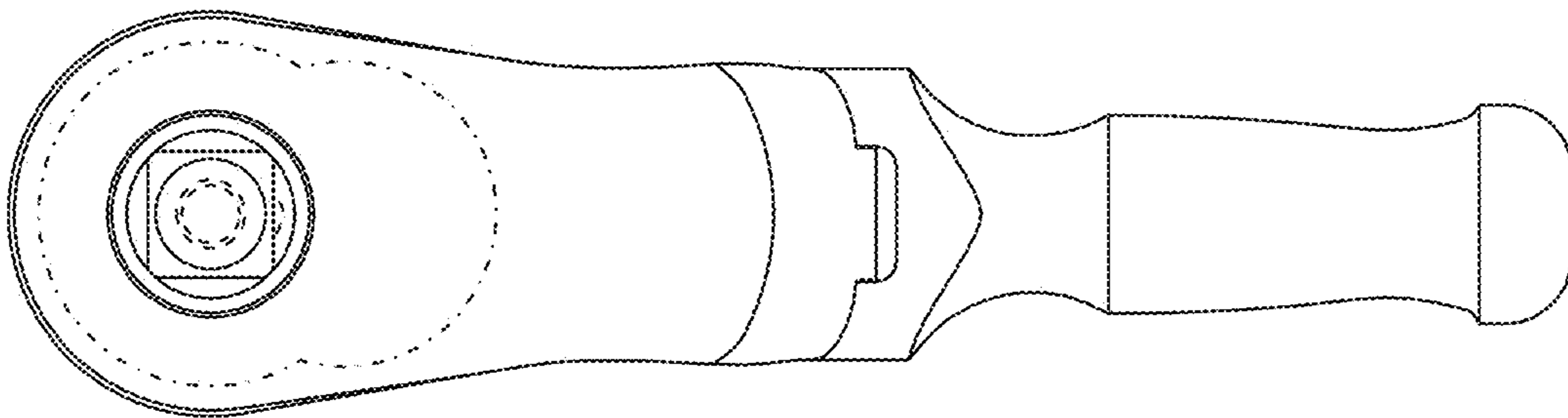

Fig. 6

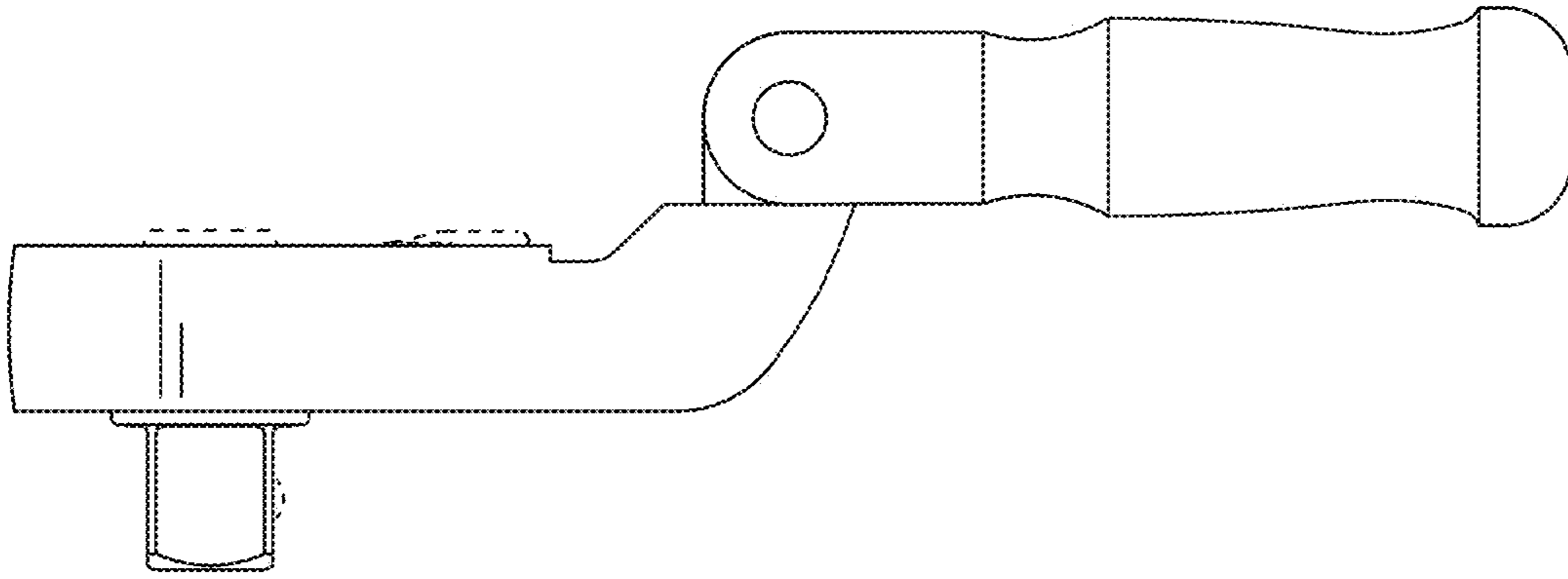

Fig. 7

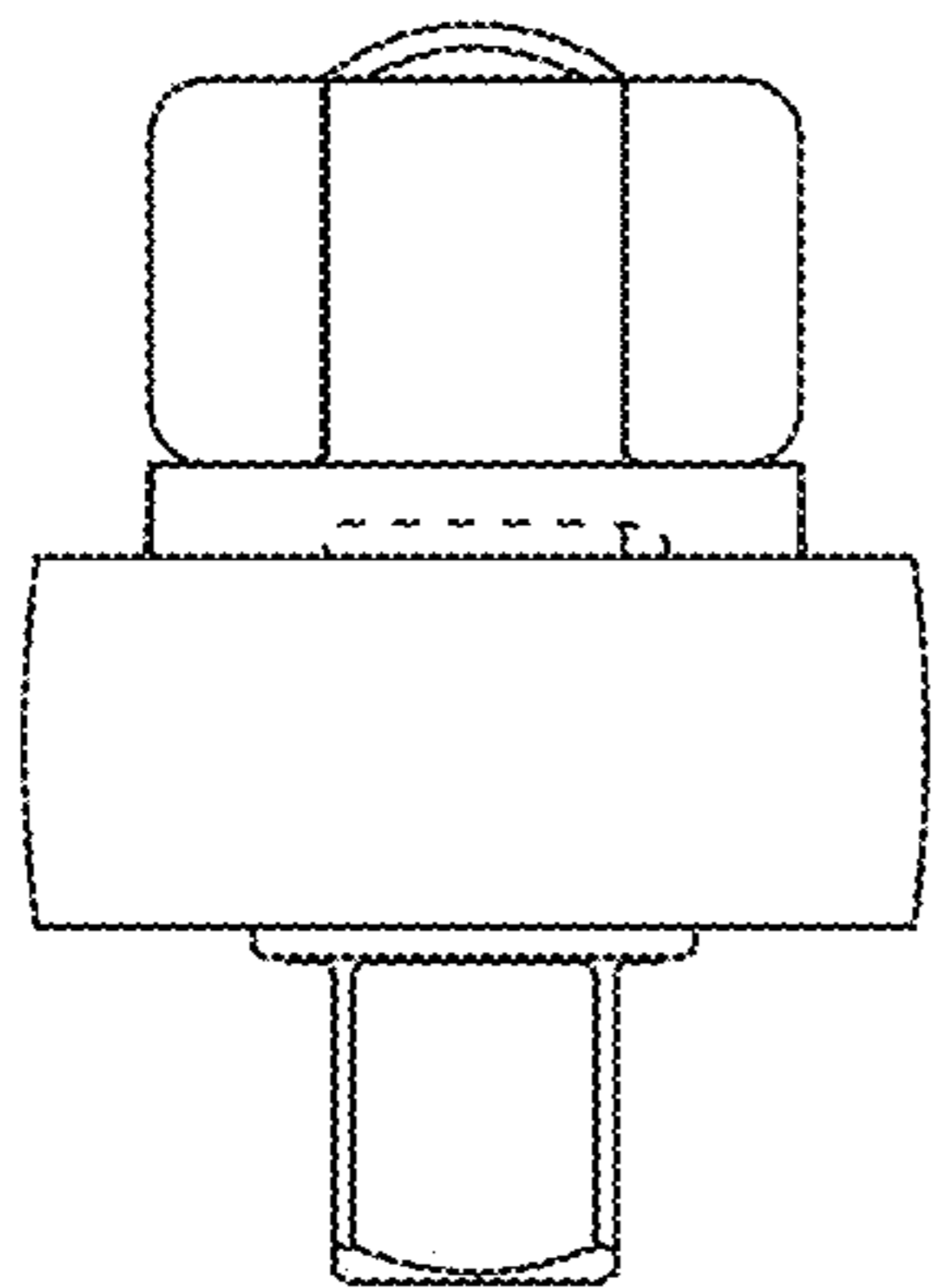

Fig. 8

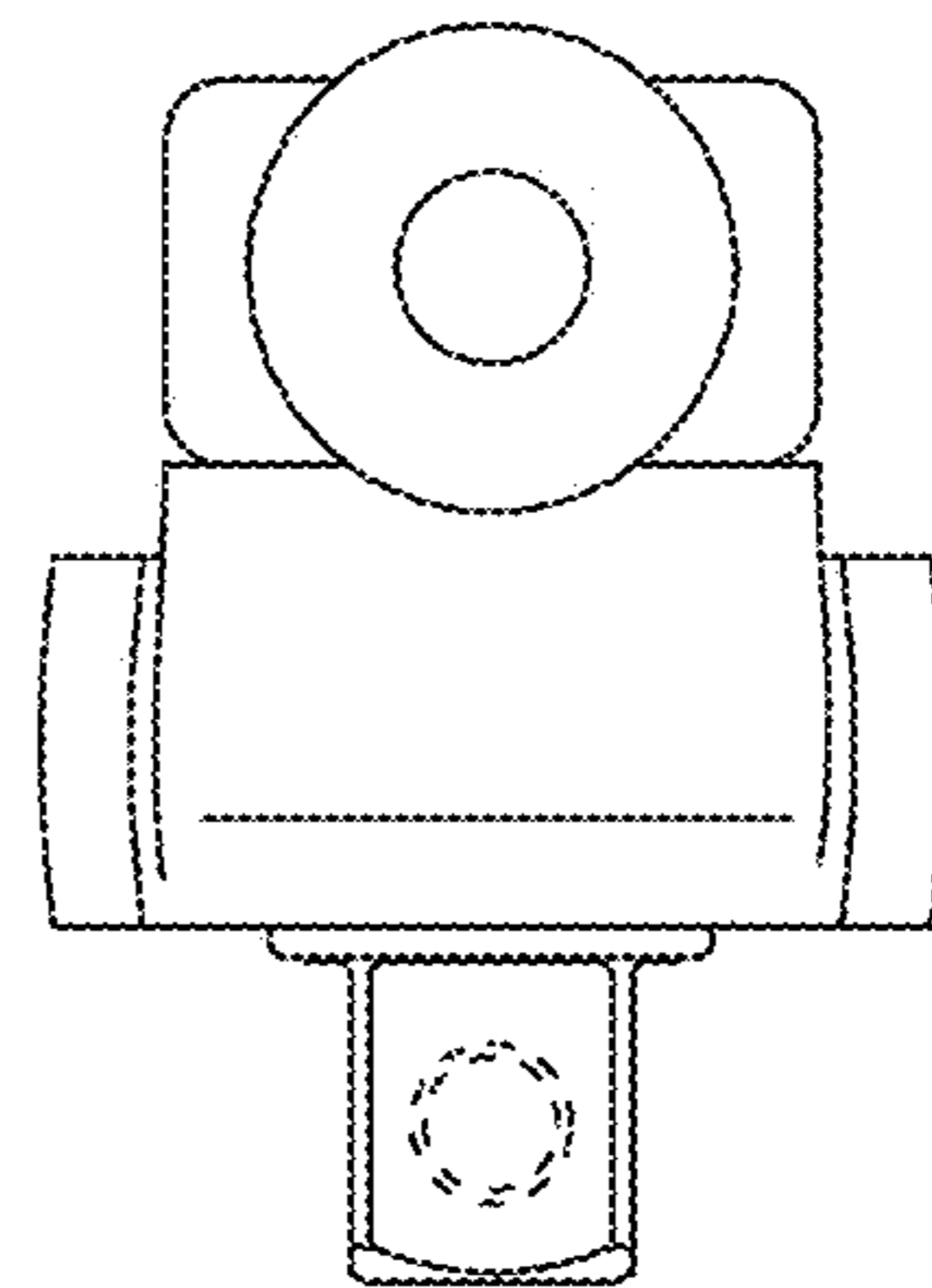

Fig. 9