



US00D966165S

(12) **United States Design Patent** (10) **Patent No.:** **US D966,165 S**
Liu (45) **Date of Patent:** **** Oct. 11, 2022**

(54) **FUEL TANK CAP**

FOREIGN PATENT DOCUMENTS

(71) Applicant: **Luffy Zongxian Liu**, Chino, CA (US)

EP 1162099 A2 * 12/2001 B60K 15/04
JP 2003267419 A * 9/2003
JP 2006224775 A * 8/2006
JP 2013256297 A * 12/2013

(72) Inventor: **Luffy Zongxian Liu**, Chino, CA (US)

(**) Term: **15 Years**

OTHER PUBLICATIONS

(21) Appl. No.: **29/841,532**

Polaris ATV Gas Tank Cap. Date first available: Dec. 16, 2014. Site visited: Jul. 22, 2022. Available online: https://www.amazon.com/CAP-GAS-TANK-Genuine-Polaris-Snowmobile/dp/B00R3JFSOE/ref=sr_1_7_mod_primary_new (Year: 2014).*

(22) Filed: **Jun. 7, 2022**

Kawasaki Jet Ski Fuel Gas Cap. Date first available: Jul. 26, 2017. Site visited: Jul. 22, 2022. Available online: https://www.amazon.com/dp/B0748ZWPP8/ref=sspa_dk_detail_0 (Year: 2017).*

(51) **LOC (13) Cl.** **12-16**

(52) **U.S. Cl.**

USPC **D12/197**

(58) **Field of Classification Search**

USPC D12/197–201, 317, 114, 216, 218, 400;
D9/451–454, 443–444, 435, 439;
D23/249, 260; D14/214, 204, 210, 215,
D14/216; 362/157–158, 183–208;
D8/310–312, 107, 397, 343, 342, 331
CPC B60K 15/04; B60K 15/0406; B60K 15/05;
B60H 1/34; B62K 19/06; B62K 19/08;
B62K 19/48; B62K 19/32

See application file for complete search history.

* cited by examiner

Primary Examiner — Catherine S Posthauer

Assistant Examiner — Joan E. Diehl

(57) **CLAIM**

The ornamental design for a fuel tank cap, as shown and described.

DESCRIPTION

(56) **References Cited**

U.S. PATENT DOCUMENTS

D313,084 S * 12/1990 Bramble D26/113
D397,320 S * 8/1998 Hoagland, IV D12/197
D477,554 S * 7/2003 Keefer D12/197
D488,397 S * 4/2004 Morelock D10/68
D512,627 S * 12/2005 Okada D8/343
D594,395 S * 6/2009 Yoshii D12/197
D637,081 S * 5/2011 Collins D9/453
D638,294 S * 5/2011 Heidel D9/453
D649,099 S * 11/2011 Nakamura D12/197
D687,755 S * 8/2013 Griffin D12/197
D754,304 S * 4/2016 Morris D23/260
D756,280 S * 5/2016 Davito D12/197
D934,144 S * 10/2021 Chen D12/197
D938,556 S 12/2021 Zhang

FIG. 1 is a front and top perspective view of a fuel tank cap, showing my new design;

FIG. 2 is a rear and bottom perspective view thereof;

FIG. 3 is a front elevation view thereof;

FIG. 4 is a rear elevation view thereof;

FIG. 5 is a left side elevation view thereof;

FIG. 6 is a right side elevation view thereof;

FIG. 7 is a top plan view thereof;

FIG. 8 is a bottom plan view thereof; and,

FIG. 9 is another perspective view thereof, shown in an alternative position.

The broken lines in the figures illustrate portions of the fuel tank cap that form no part of the claimed design.

1 Claim, 9 Drawing Sheets

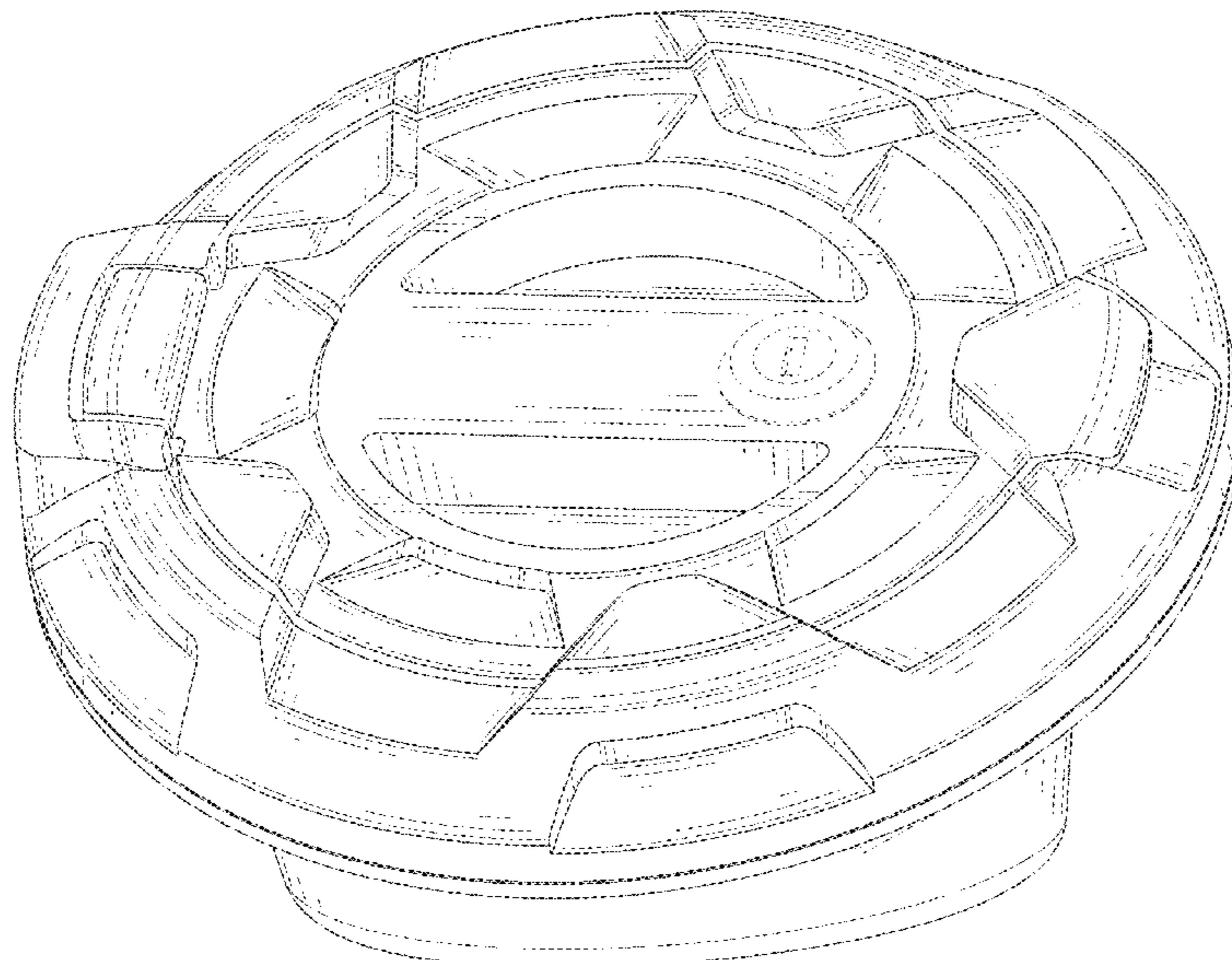

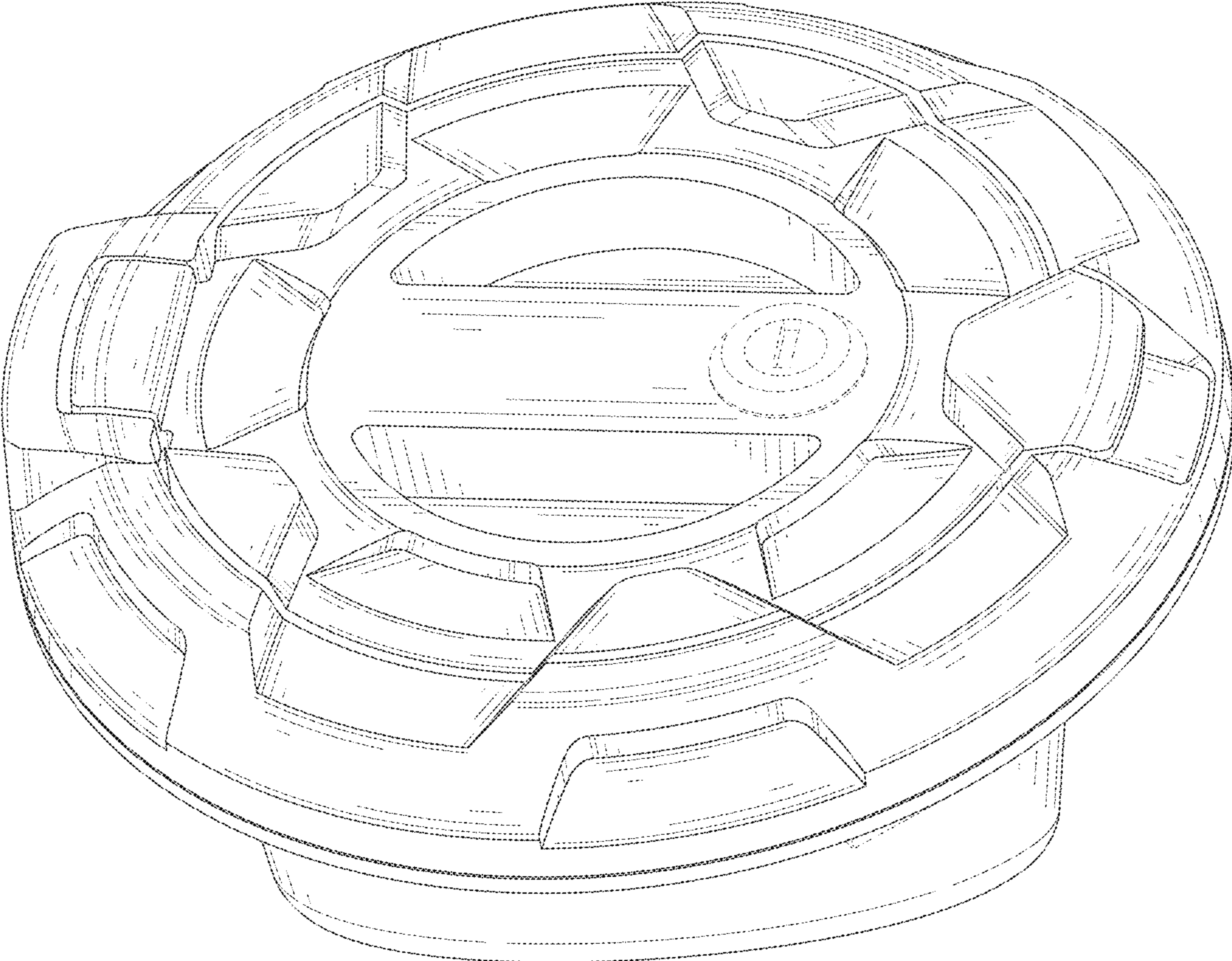

FIG. 1

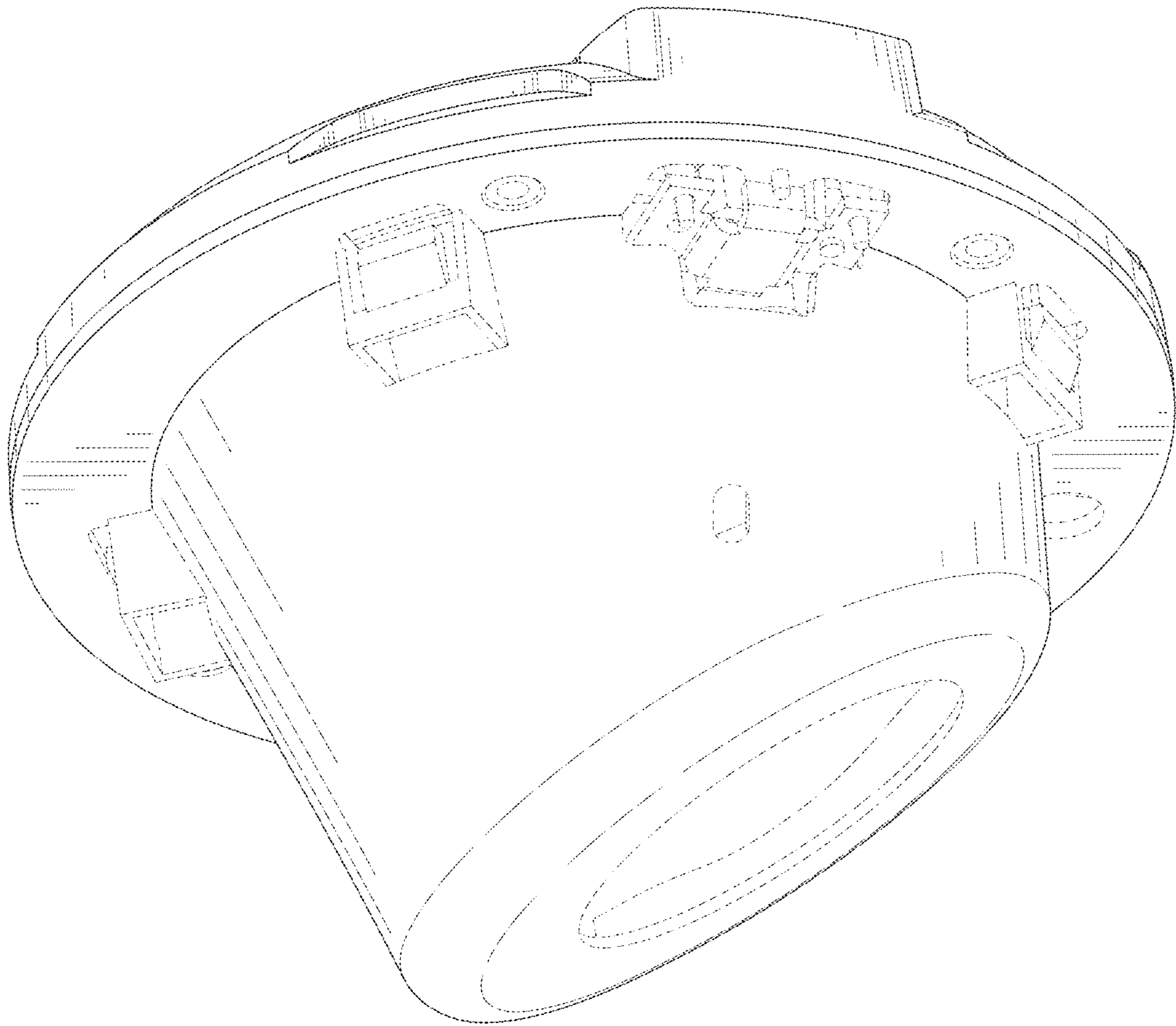

FIG. 2

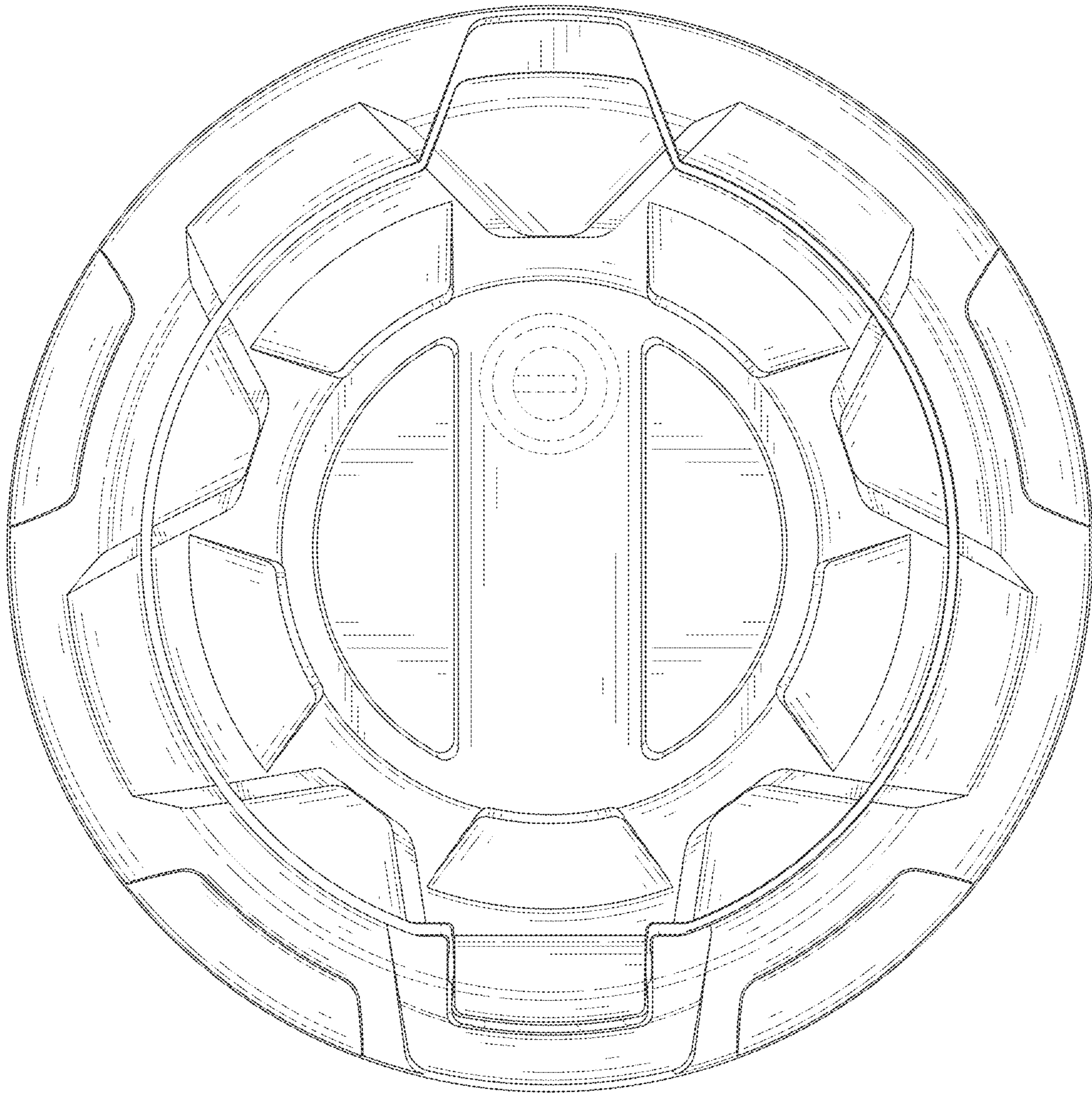

FIG. 3

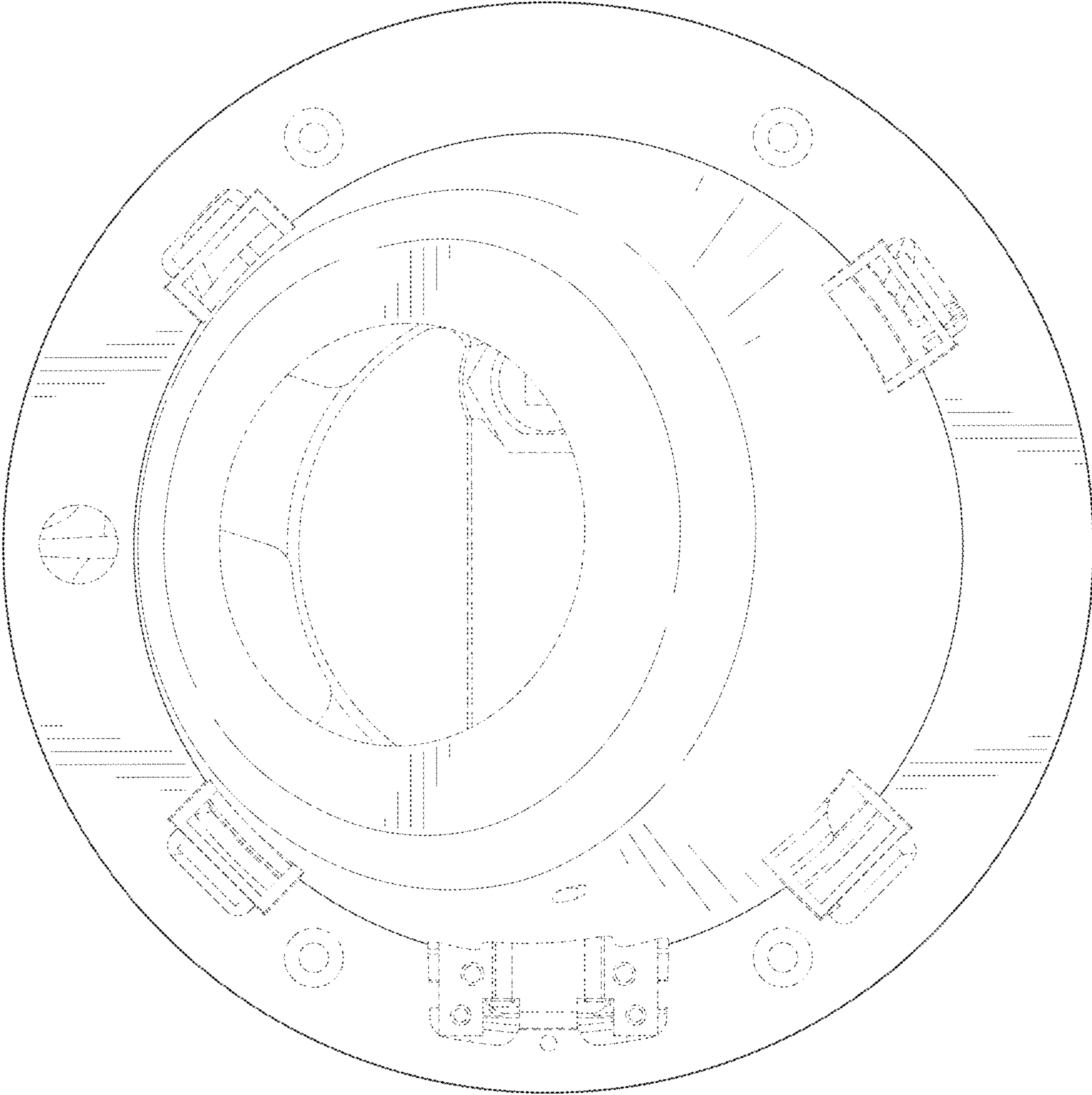

FIG. 4

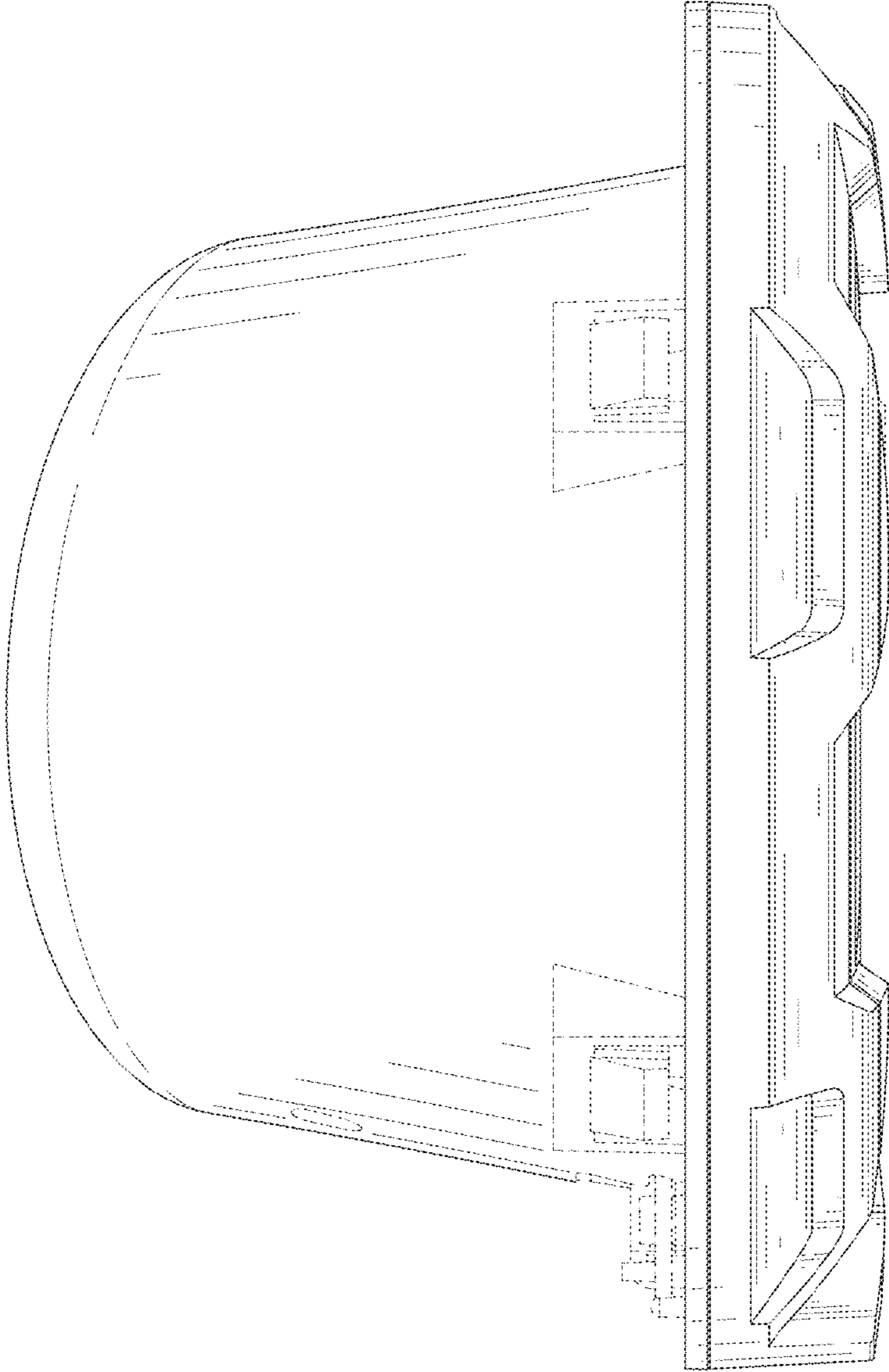

FIG. 5

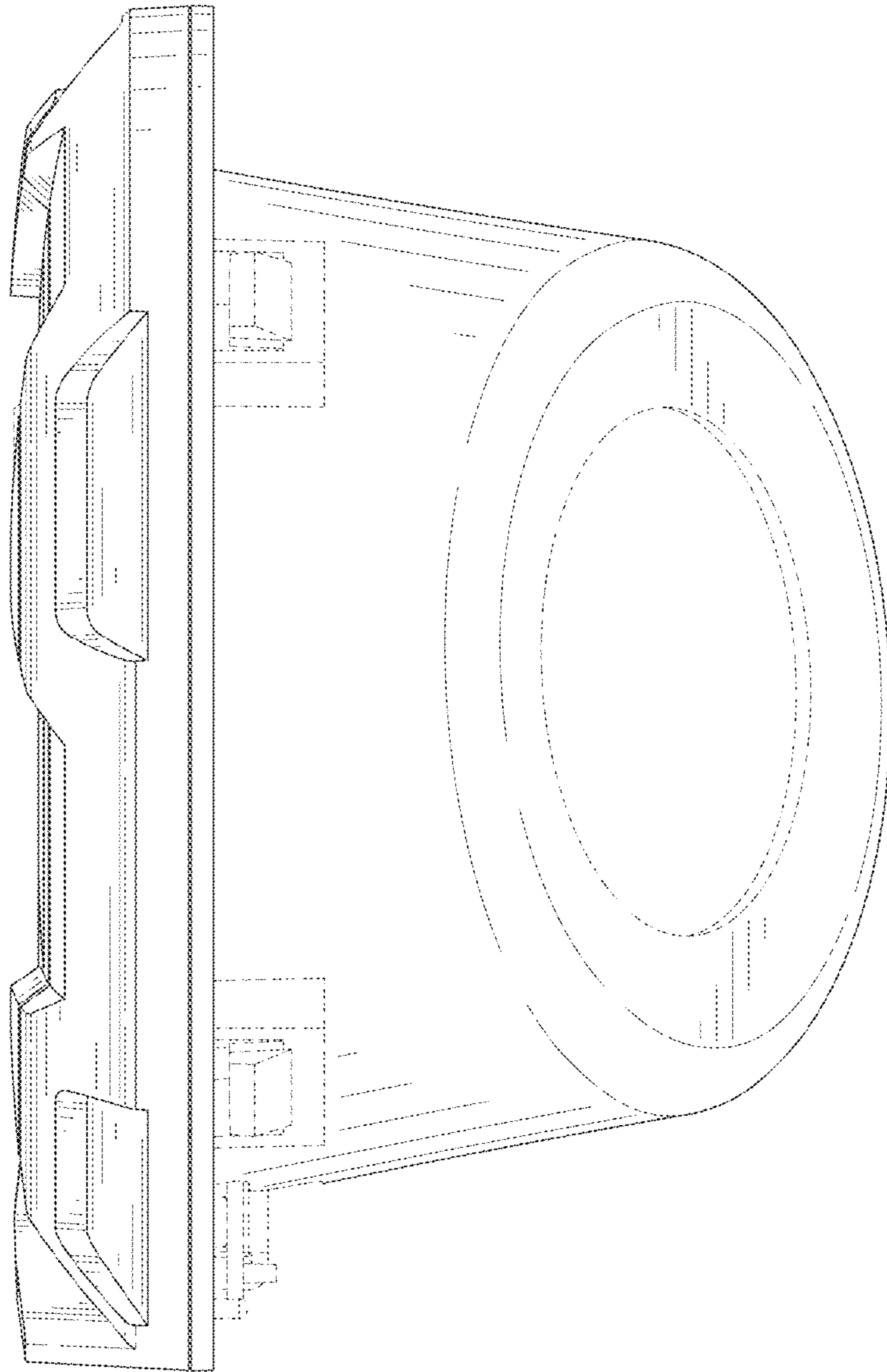

FIG. 6

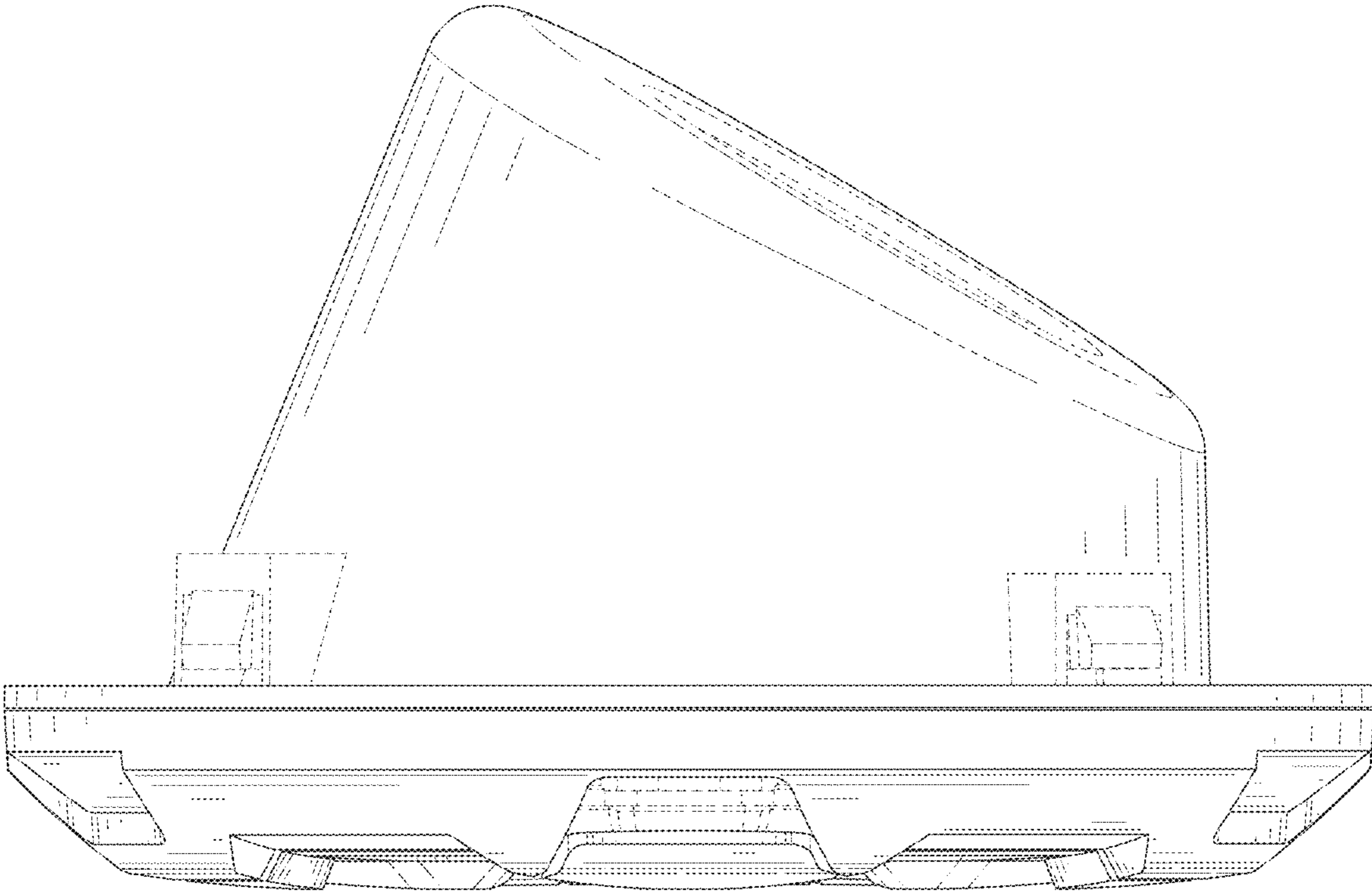

FIG. 7

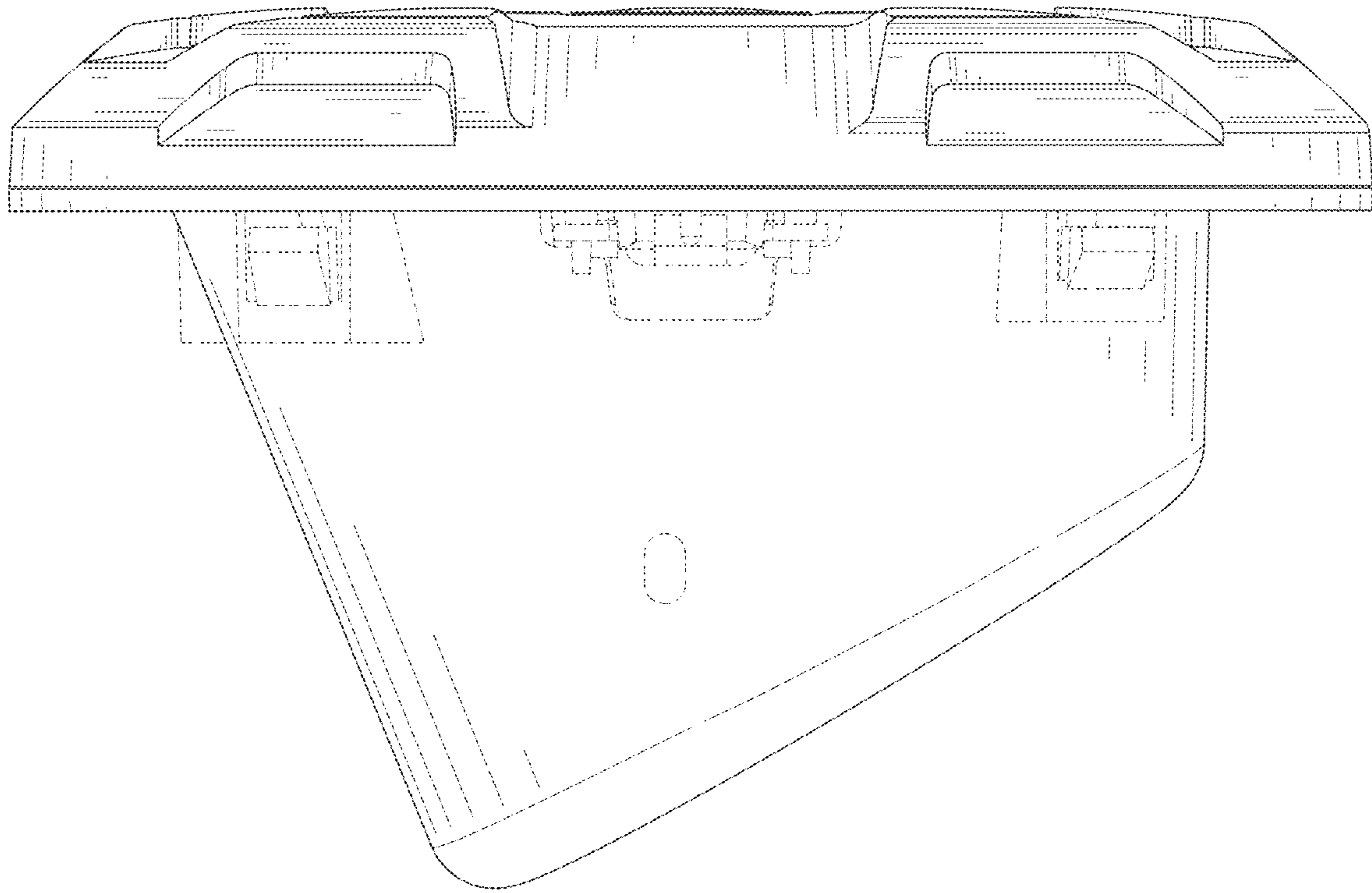

FIG. 8

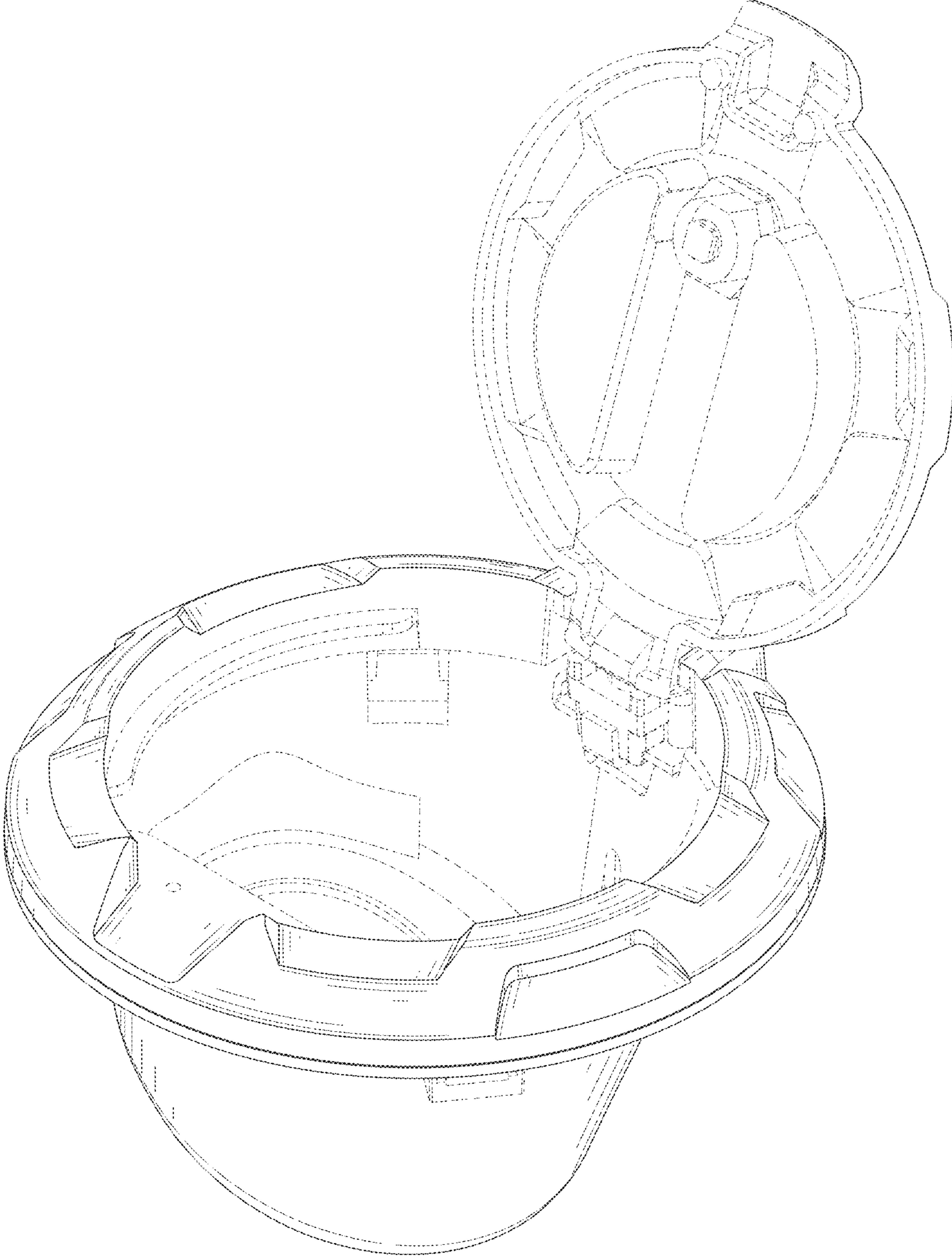

FIG. 9