

US00D966146S

(12) **United States Design Patent** (10) **Patent No.:** **US D966,146 S**  
**Merrill et al.** (45) **Date of Patent:** **\*\* Oct. 11, 2022**

(54) **TRANSPORTABLE UNMANNED CARGO DELIVERY AIRCRAFT**

(71) Applicant: **Elroy Air, Inc.**, San Francisco, CA (US)

(72) Inventors: **David Merrill**, San Francisco, CA (US); **Terik Weekes**, San Francisco, CA (US); **Colin Owen**, San Francisco, CA (US); **Clinton Cope**, San Francisco, CA (US); **Isaiah Jones**, San Francisco, CA (US); **Shane Hills**, San Francisco, CA (US); **William Peters**, San Francisco, CA (US)

(73) Assignee: **ELROY AIR, INC.**, San Francisco, CA (US)

(\*\*) Term: **15 Years**

(21) Appl. No.: **29/767,438**

(22) Filed: **Jan. 22, 2021**

(51) **LOC (13) Cl.** ..... **12-07**

(52) **U.S. Cl.**  
USPC ..... **D12/16.1; D12/344**

(58) **Field of Classification Search**  
USPC ..... D12/1, 2, 3, 4, 16.1, 174, 319-345; D21/436-455  
CPC ..... B64C 29/0033; B64C 2201/021; B64C 29/02; B64C 2201/088; B64C 2201/104; B64C 2201/141  
See application file for complete search history.

(56) **References Cited**

**U.S. PATENT DOCUMENTS**

D281,680 S \* 12/1985 Henderson ..... D12/333  
4,662,588 A \* 5/1987 Henderson ..... B64C 1/36  
343/708  
D388,392 S \* 12/1997 McGinnis ..... D12/333

D418,805 S \* 1/2000 Cycon ..... D12/333  
D708,563 S \* 7/2014 Colten ..... D21/450  
D783,453 S \* 4/2017 Klick ..... D12/16.1  
D813,143 S \* 3/2018 Belik ..... D12/326  
D813,956 S \* 3/2018 McConville ..... D21/447  
D843,305 S \* 3/2019 MacAndrew ..... D12/319  
D866,394 S \* 11/2019 Shih ..... D12/16.1  
2017/0355460 A1\* 12/2017 Shannon ..... B66C 1/38

(Continued)

*Primary Examiner* — John A Voytek

(74) *Attorney, Agent, or Firm* — Martensen IP; Michael C. Martensen

(57) **CLAIM**

The ornamental design for a transportable unmanned cargo delivery aircraft, as shown and described.

**DESCRIPTION**

FIG. 1 is a top front perspective view of the transportable unmanned cargo delivery aircraft with the cargo pod.  
FIG. 2 is a bottom rear perspective view thereof.  
FIG. 3 is a front view thereof.  
FIG. 4 is a back view thereof.  
FIG. 5 is a left side view thereof.  
FIG. 6 is a right side view thereof.  
FIG. 7 is a top view thereof.  
FIG. 8 is a bottom view thereof.  
FIG. 9 is a top front perspective exploded view of the transportable unmanned cargo delivery aircraft with the cargo pod detached.  
FIG. 10 is a bottom rear perspective view thereof.  
FIG. 11 is a front view thereof.  
FIG. 12 is a back view thereof.  
FIG. 13 is a left side view thereof.  
FIG. 14 is a right side view thereof.  
FIG. 15 is a top view thereof; and,  
FIG. 16 is a bottom view thereof.

The broken lines shown in the drawings depict portions of the environment that form no part of the claimed design.

**1 Claim, 16 Drawing Sheets**

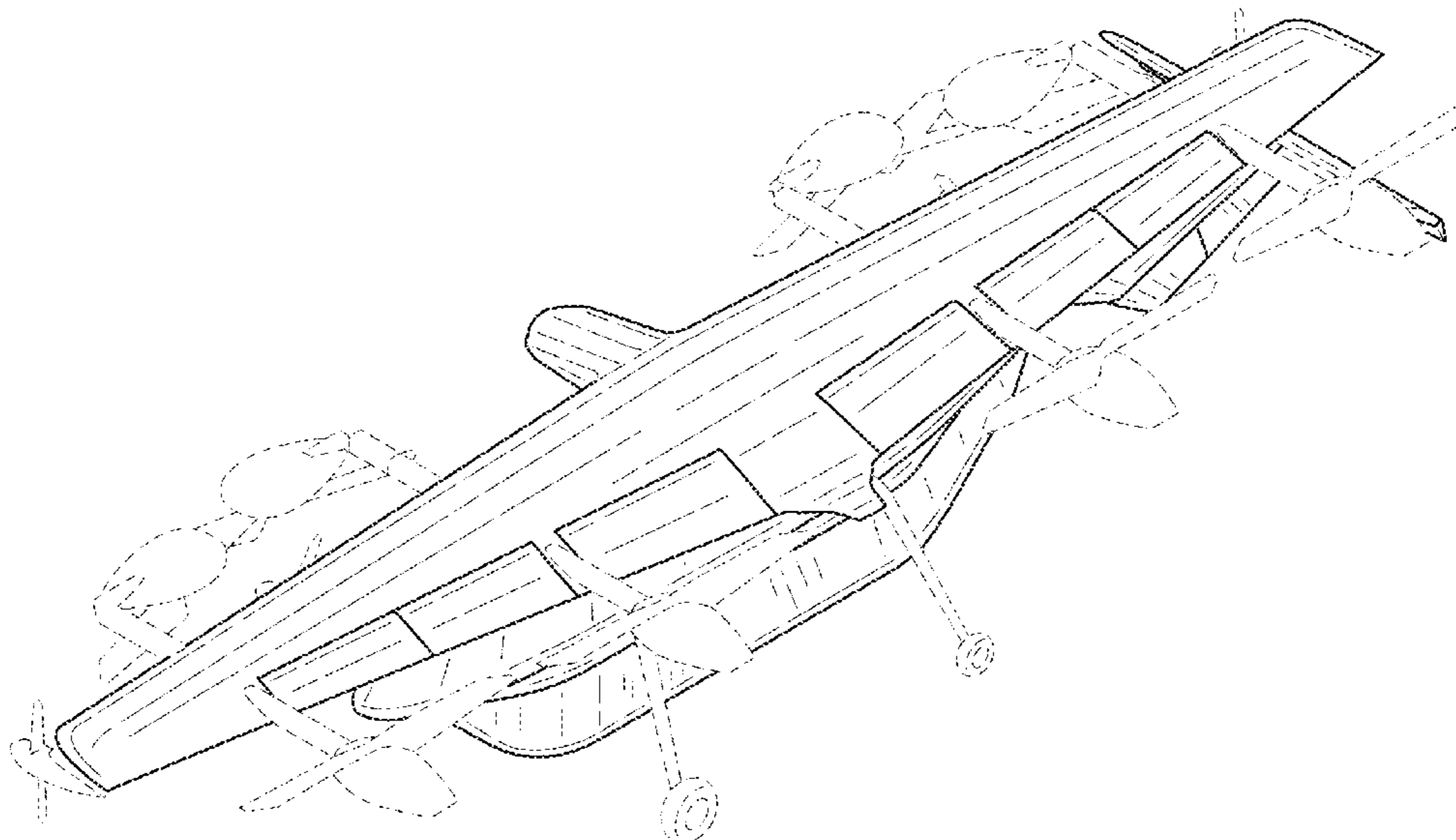

(56)

**References Cited**

U.S. PATENT DOCUMENTS

2019/0329863 A1\* 10/2019 King ..... B64C 3/185  
2019/0329867 A1\* 10/2019 Cravener ..... B64C 3/56

\* cited by examiner

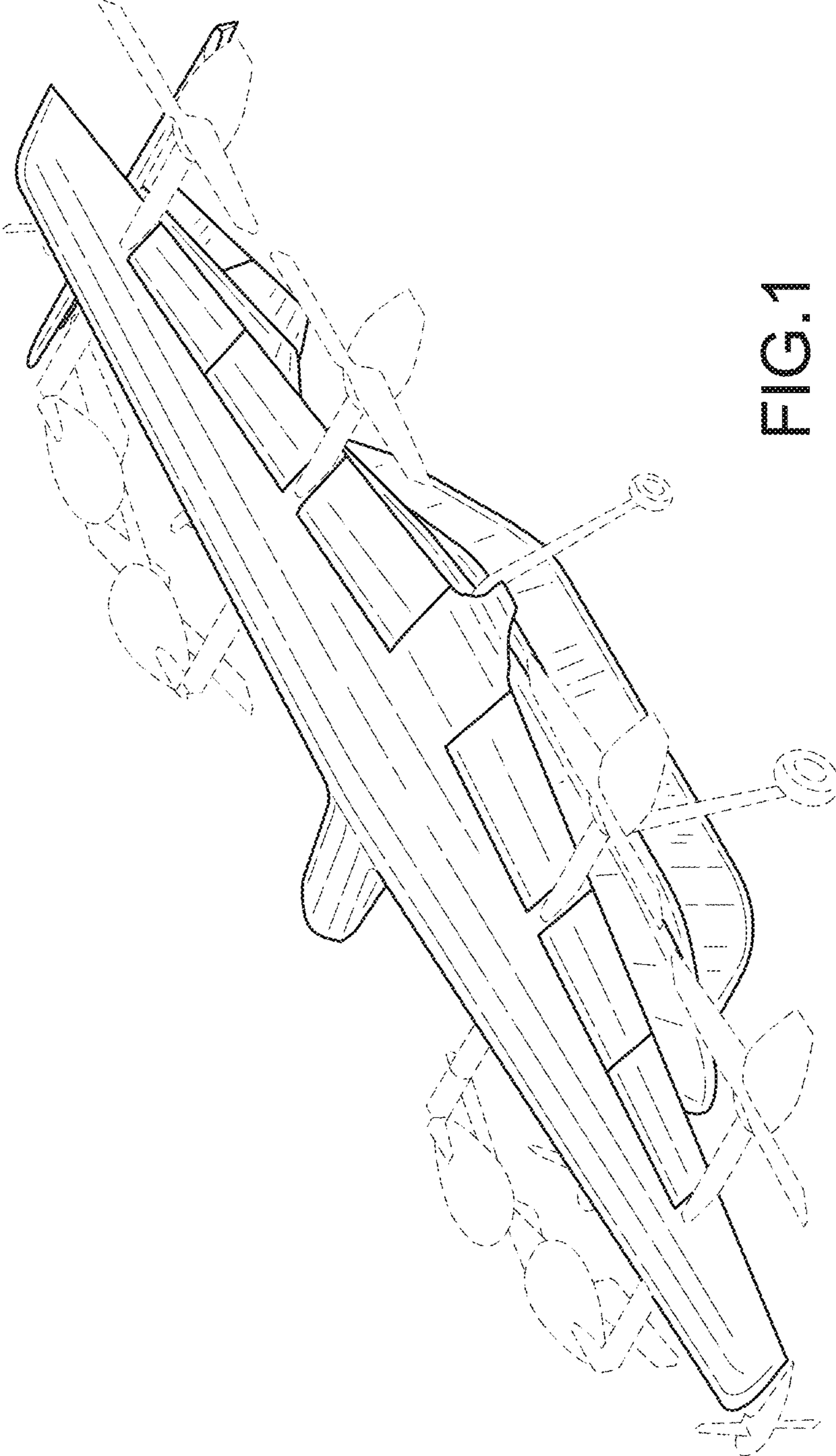

FIG.1

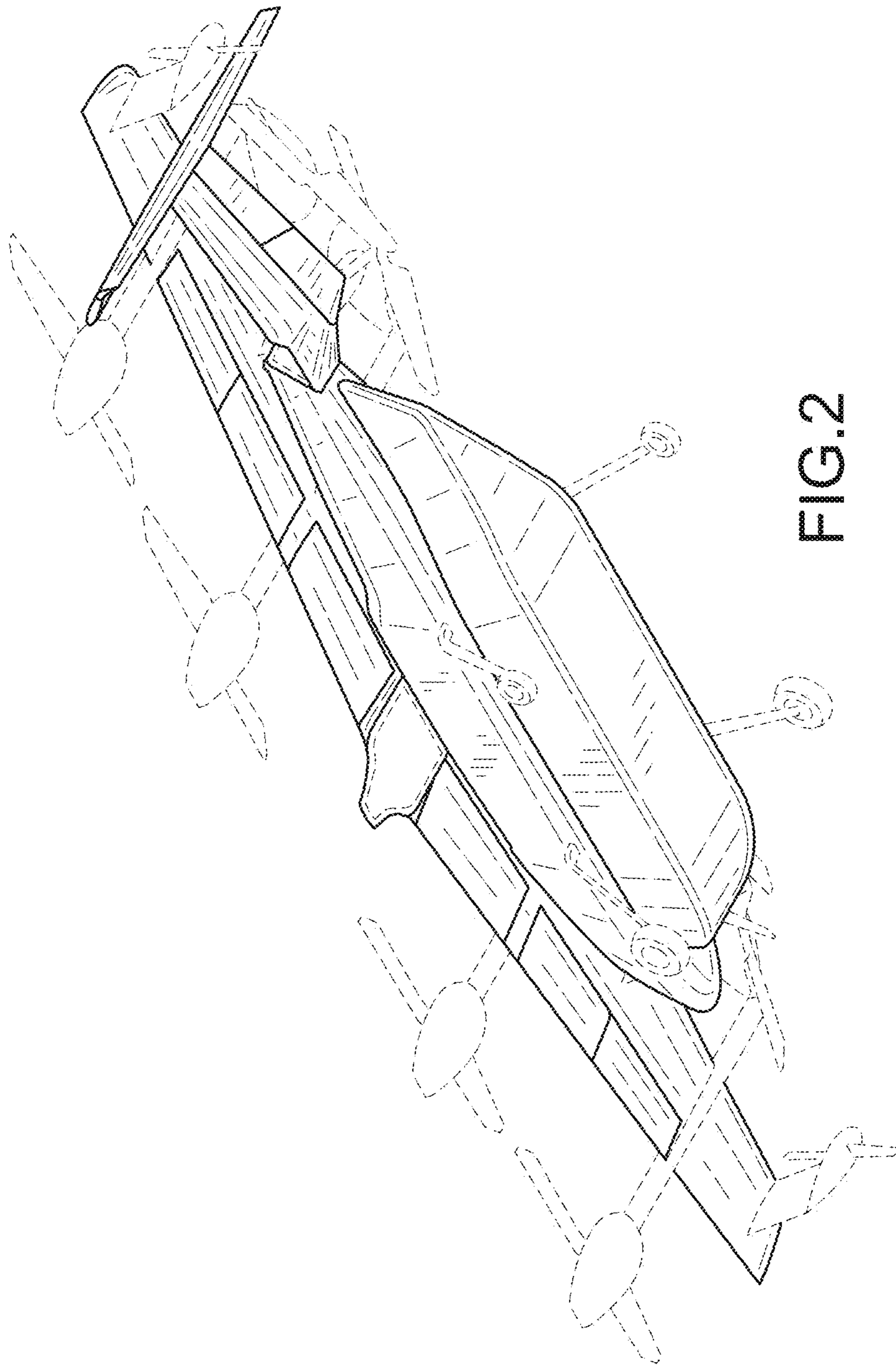

FIG. 2

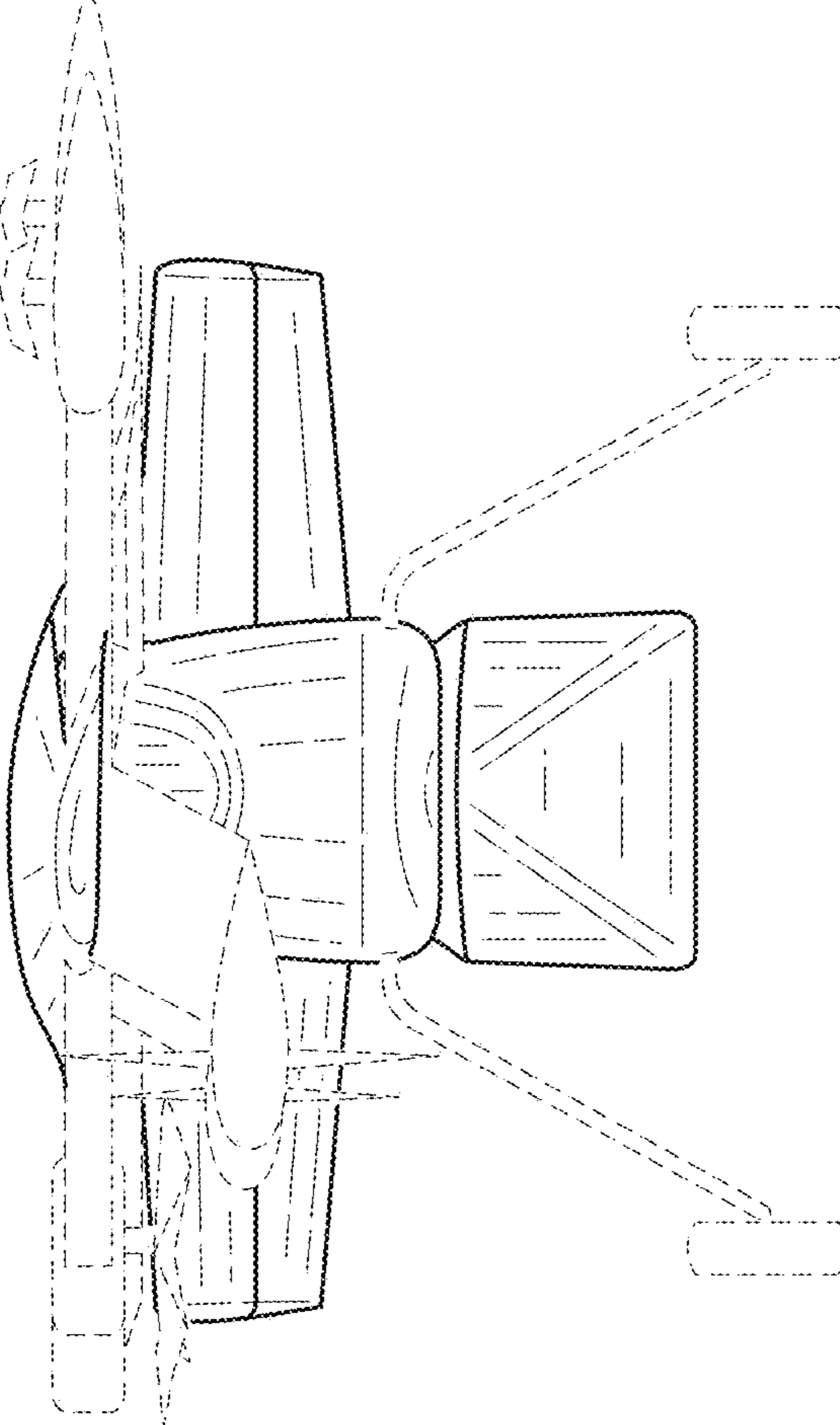

FIG.3

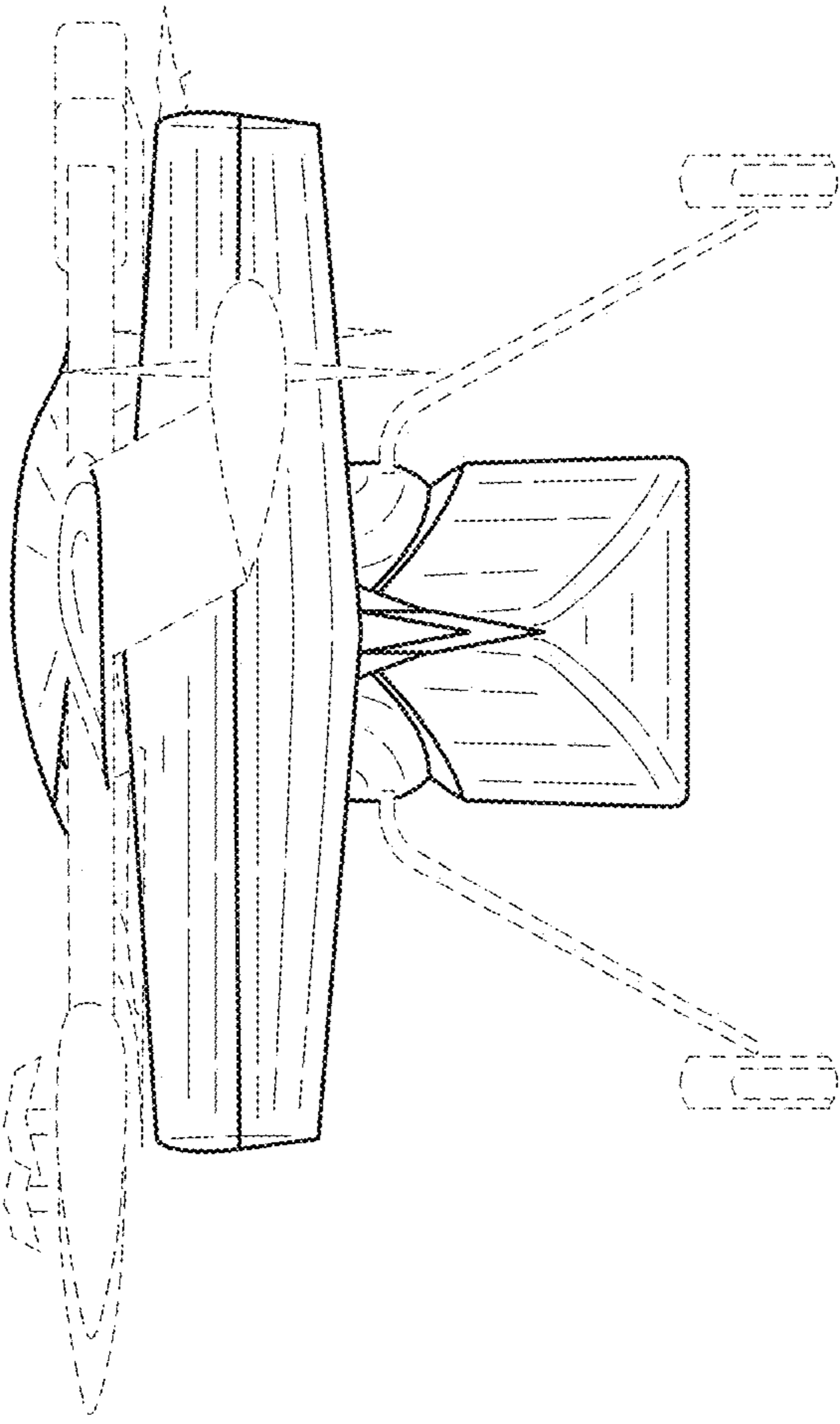

FIG.4

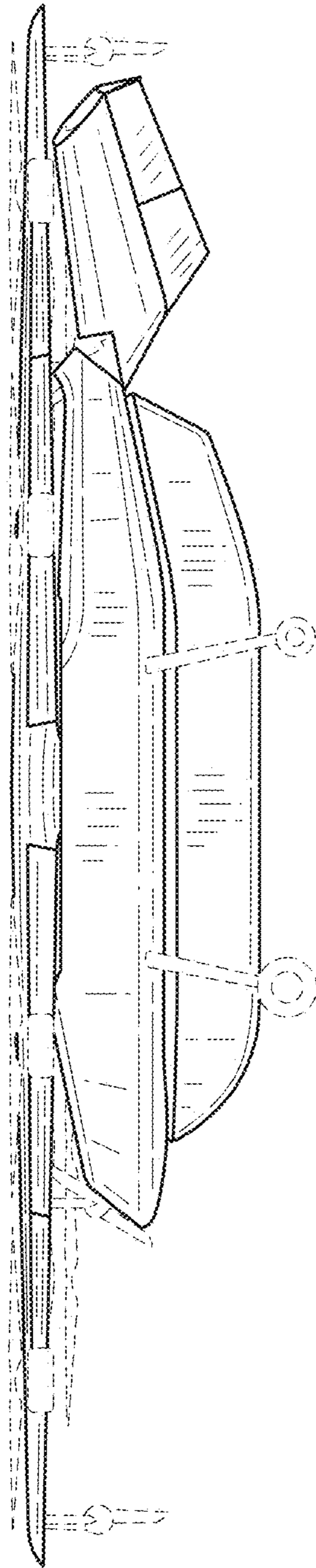

FIG. 5

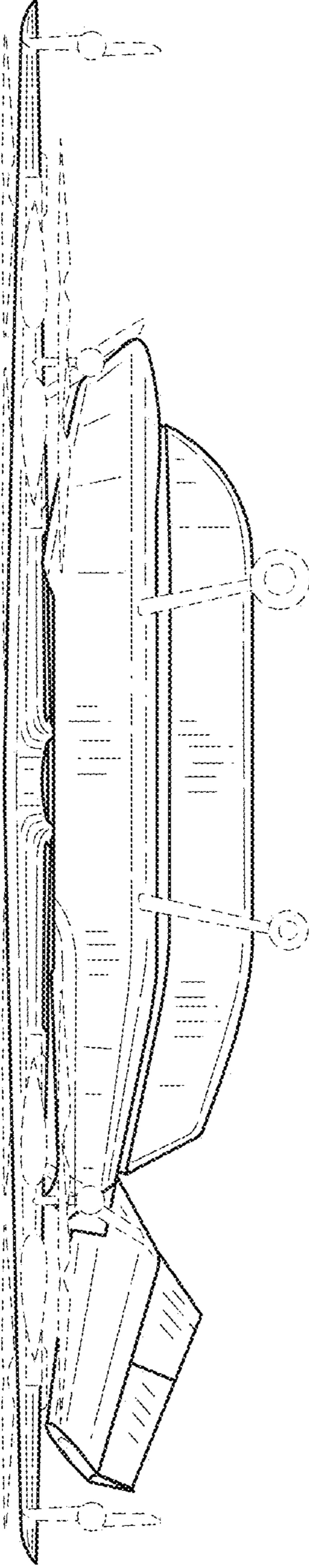

FIG.6



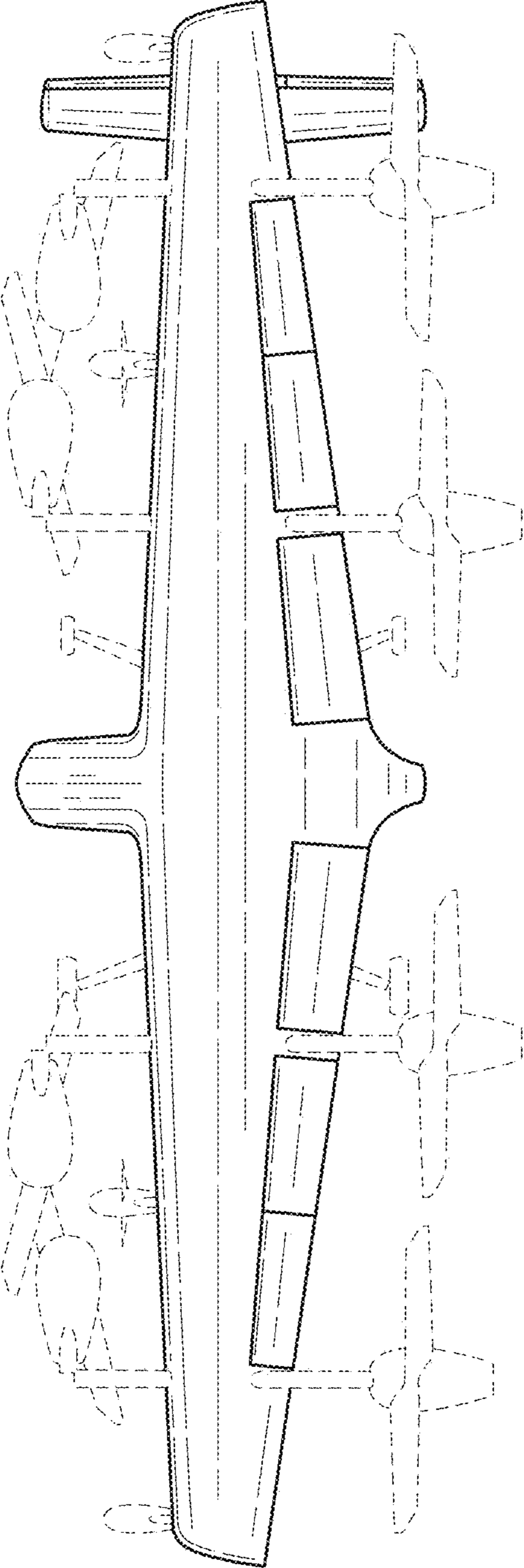

FIG.7

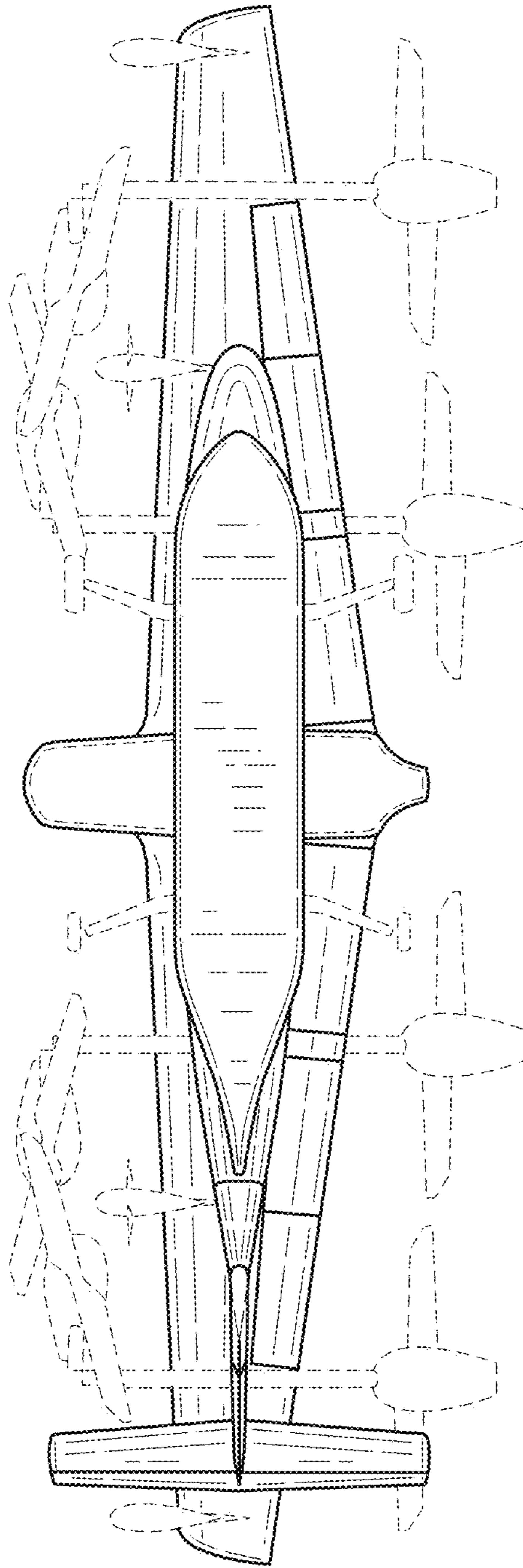

FIG.8

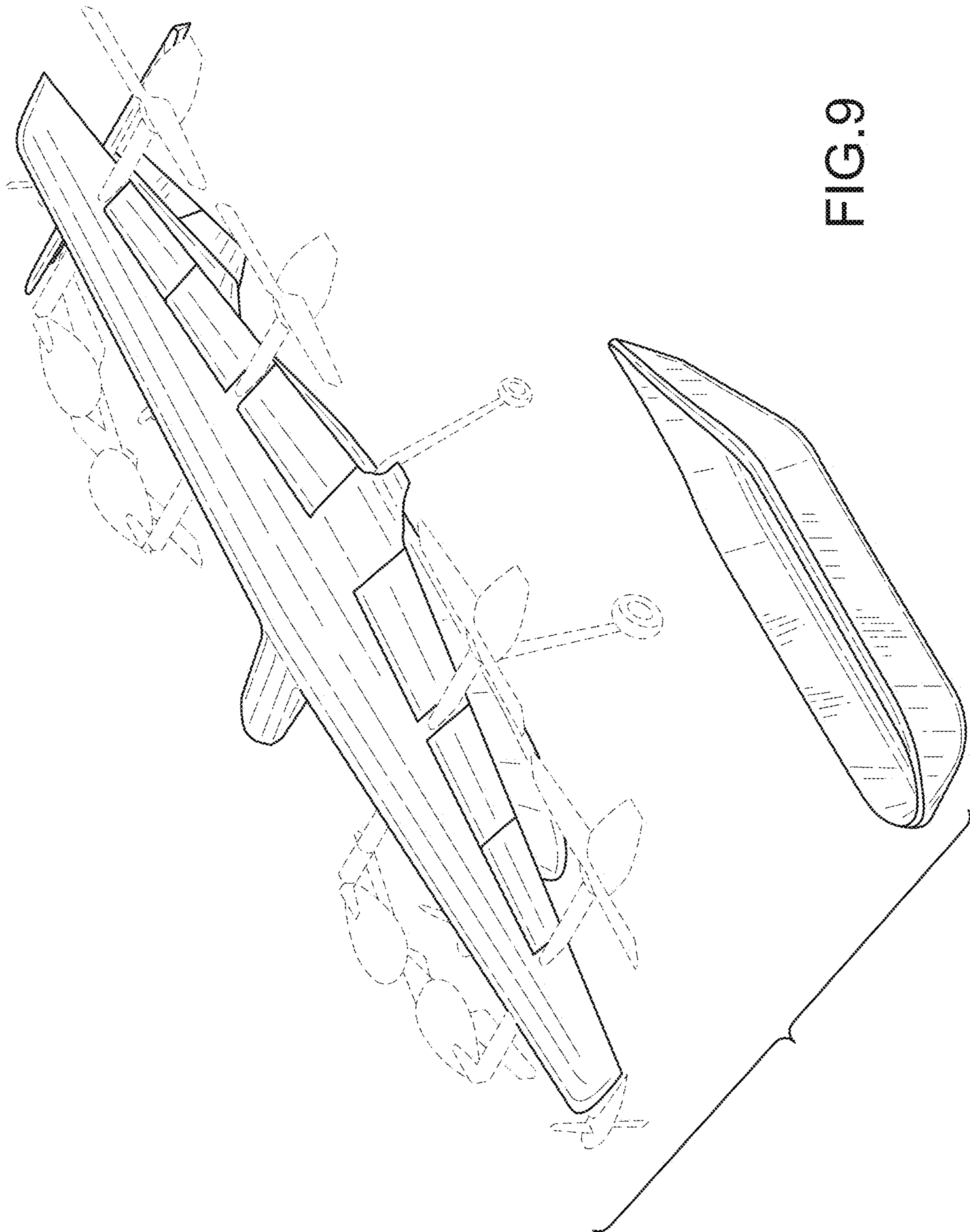

FIG. 9

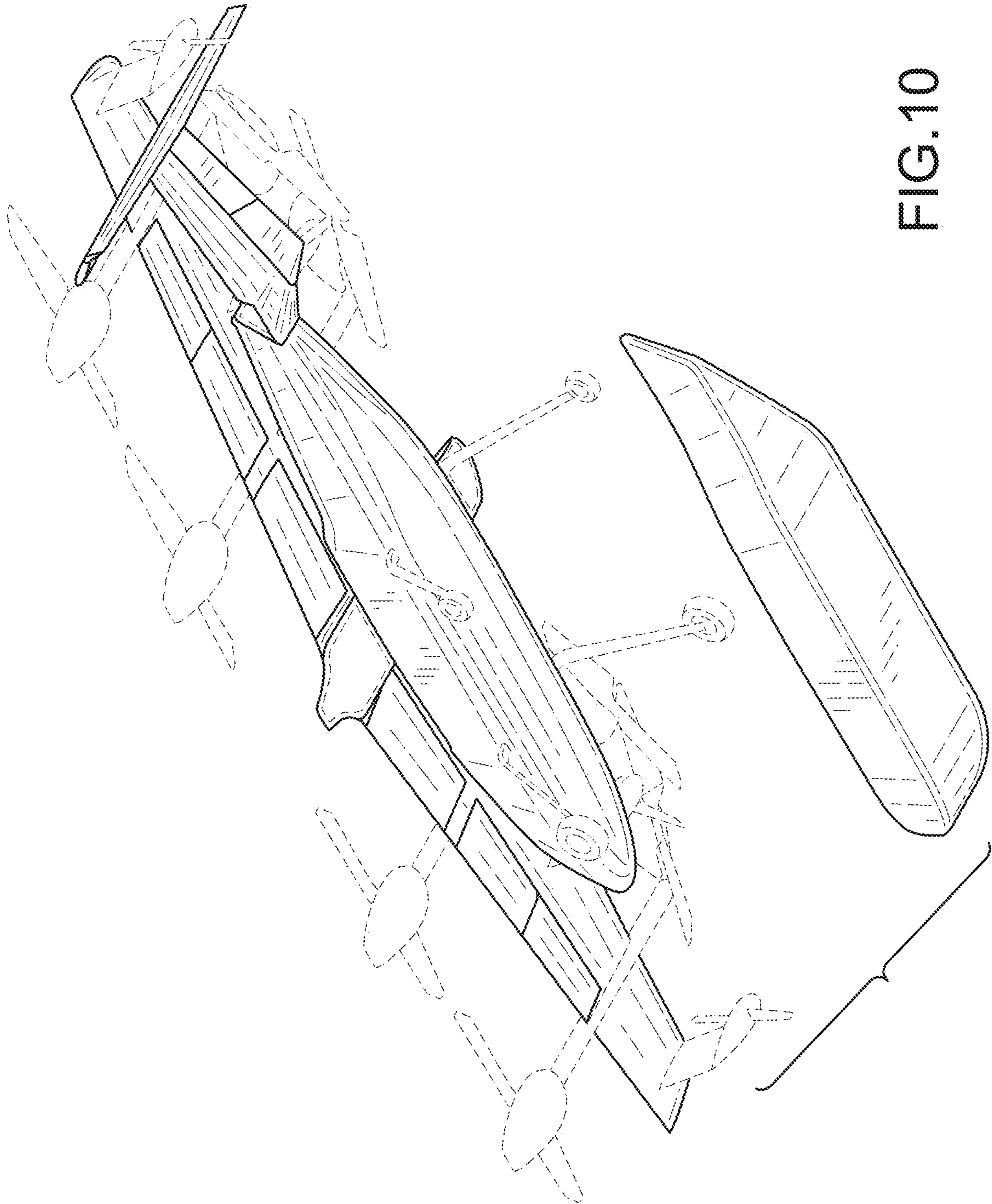

FIG. 10

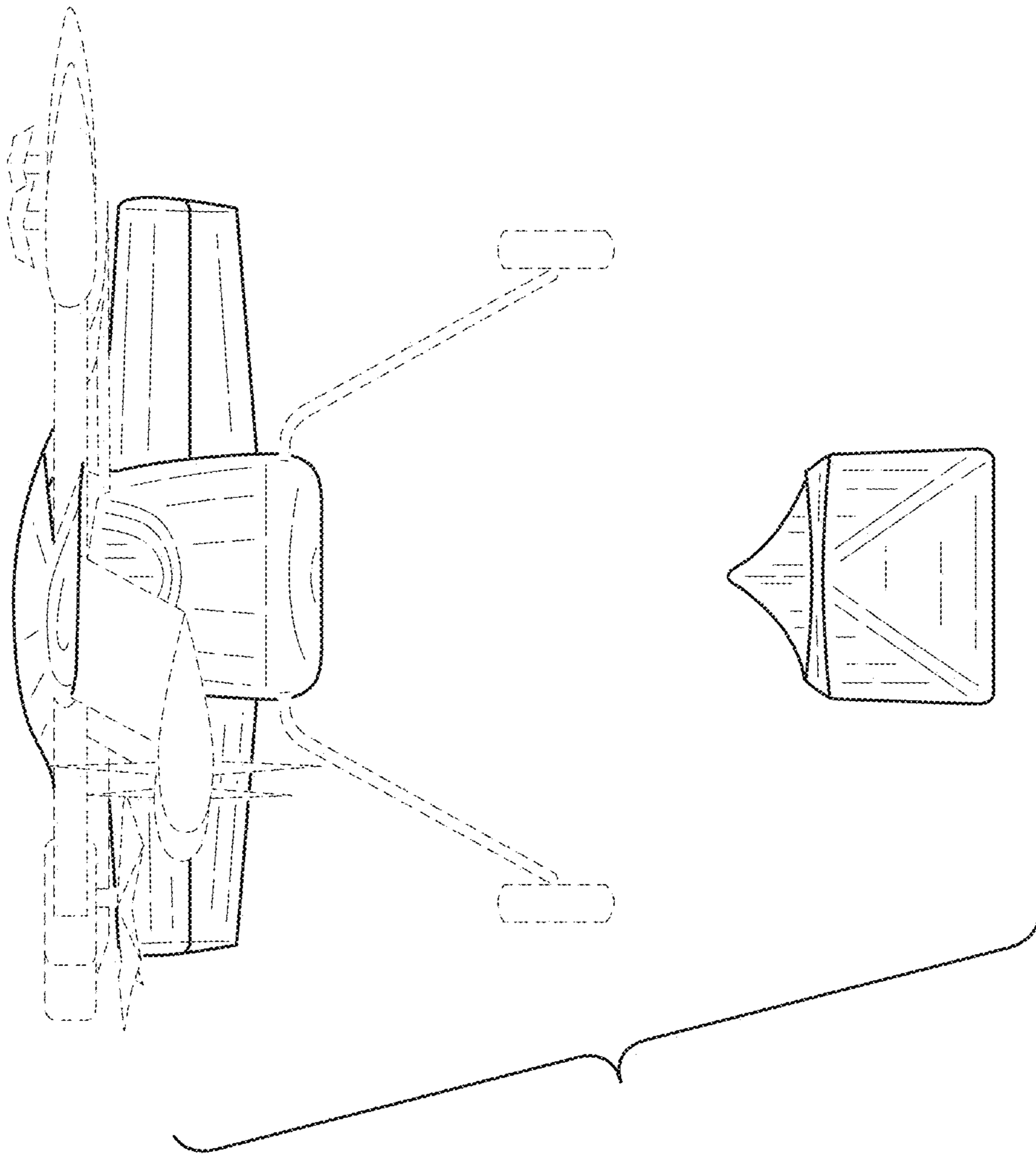

FIG. 11

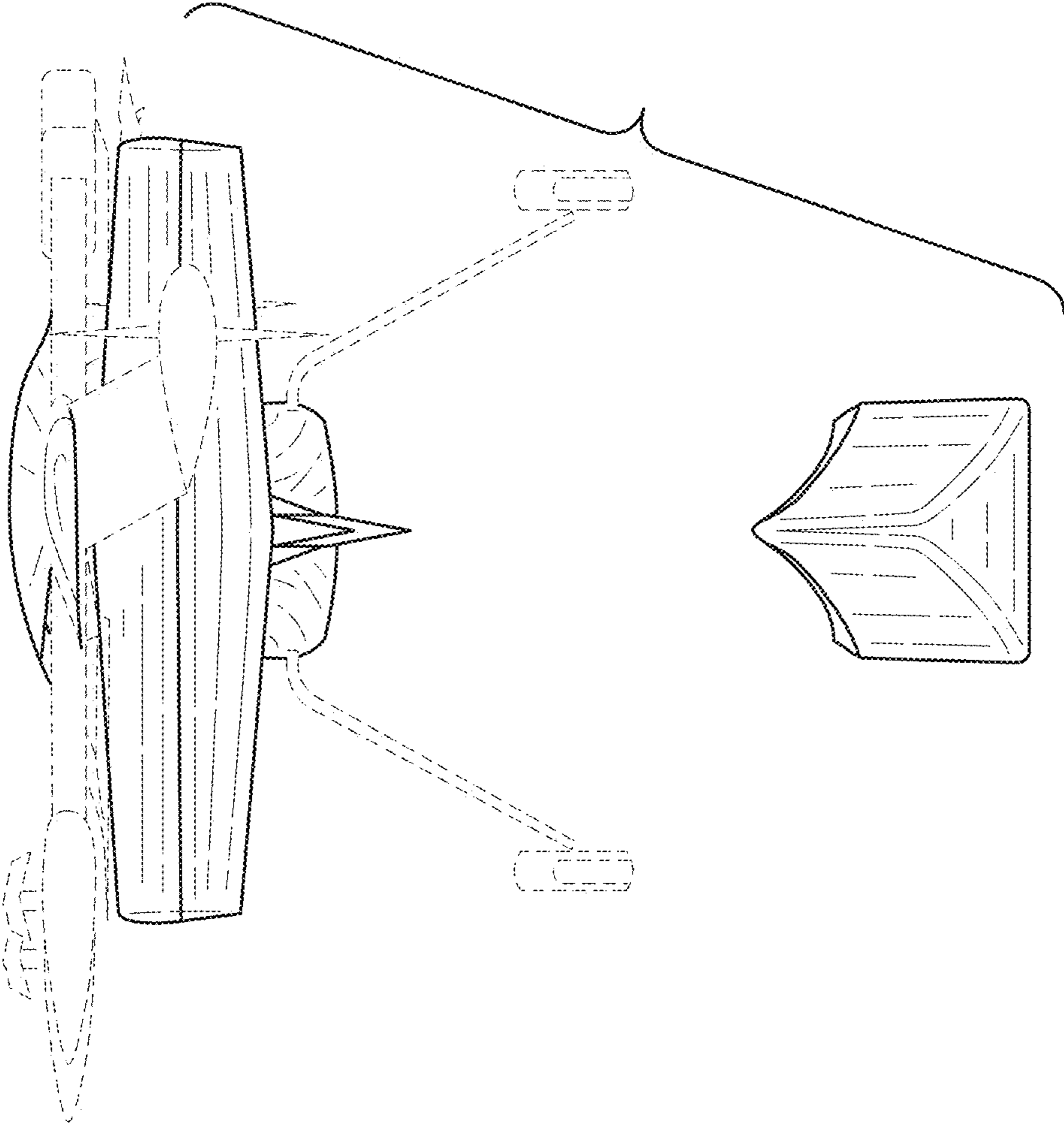

FIG.12

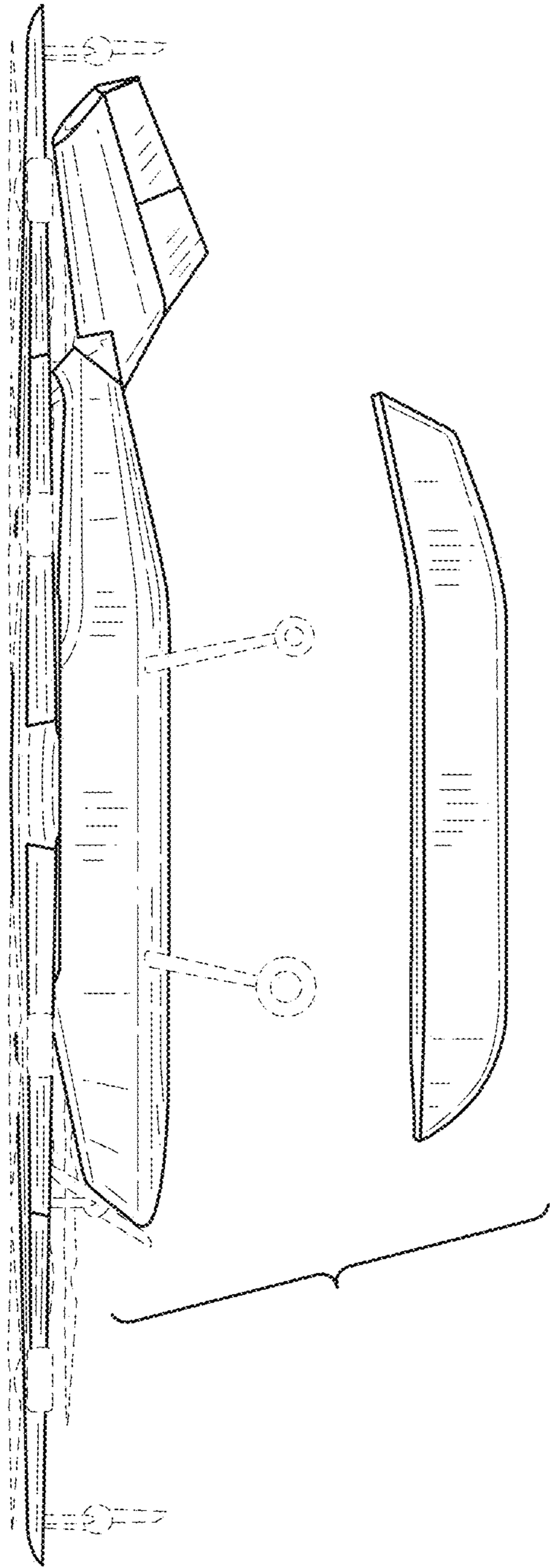

FIG.13

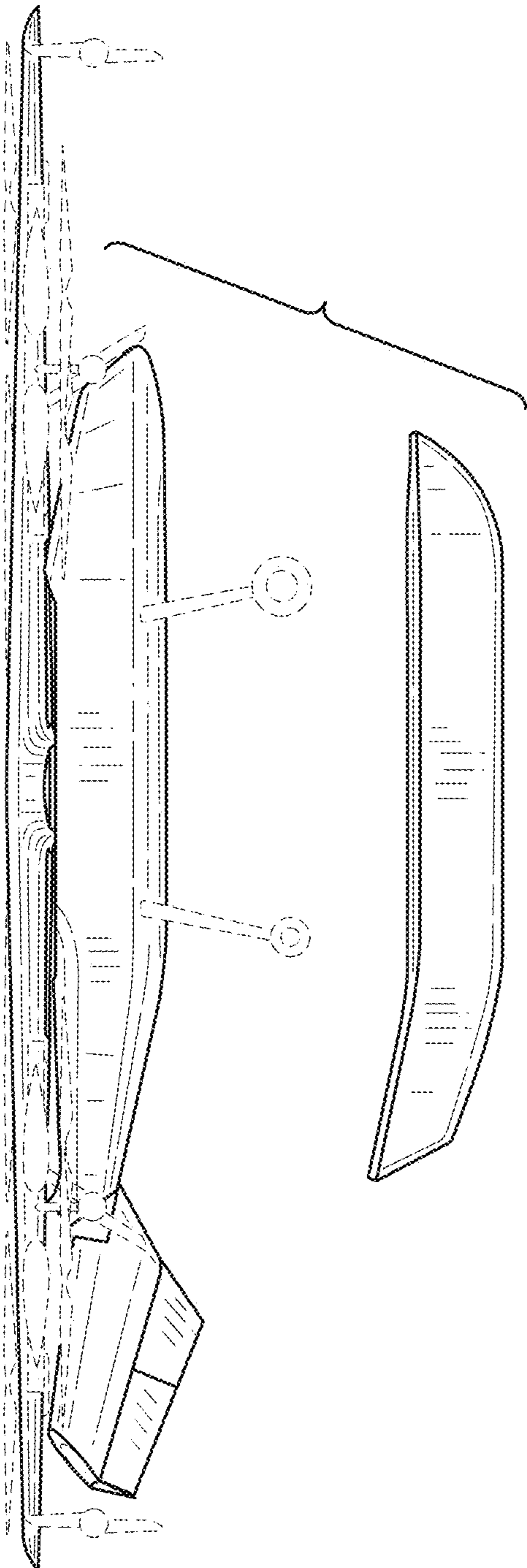

FIG.14



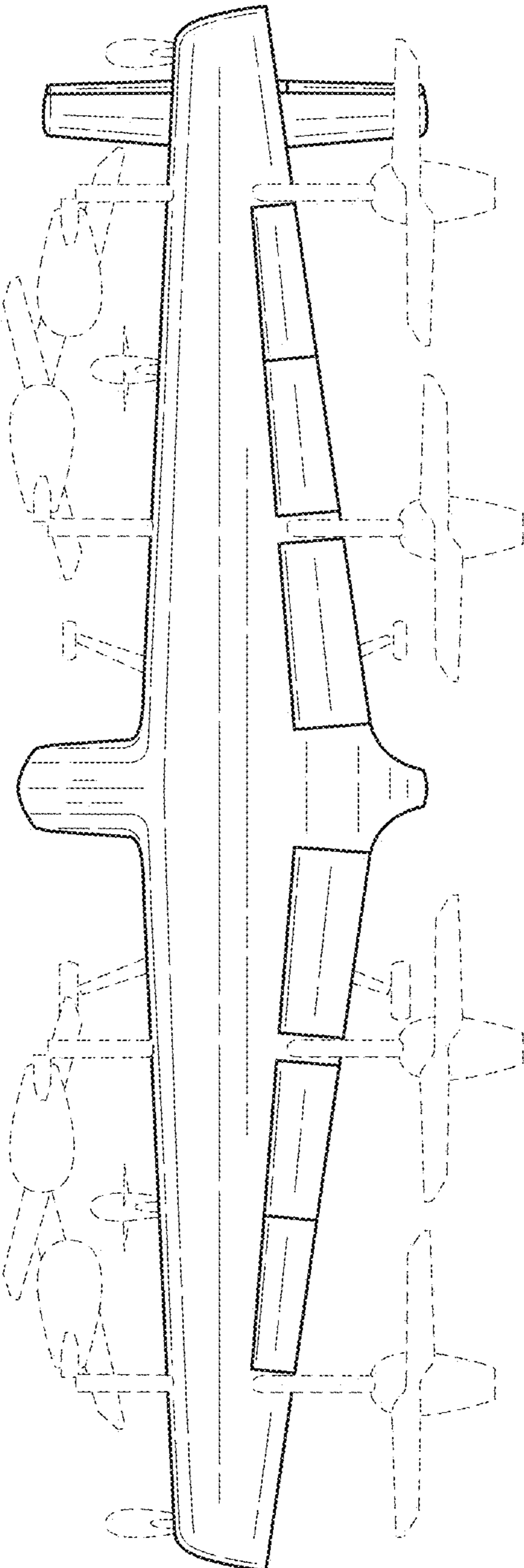

FIG.15

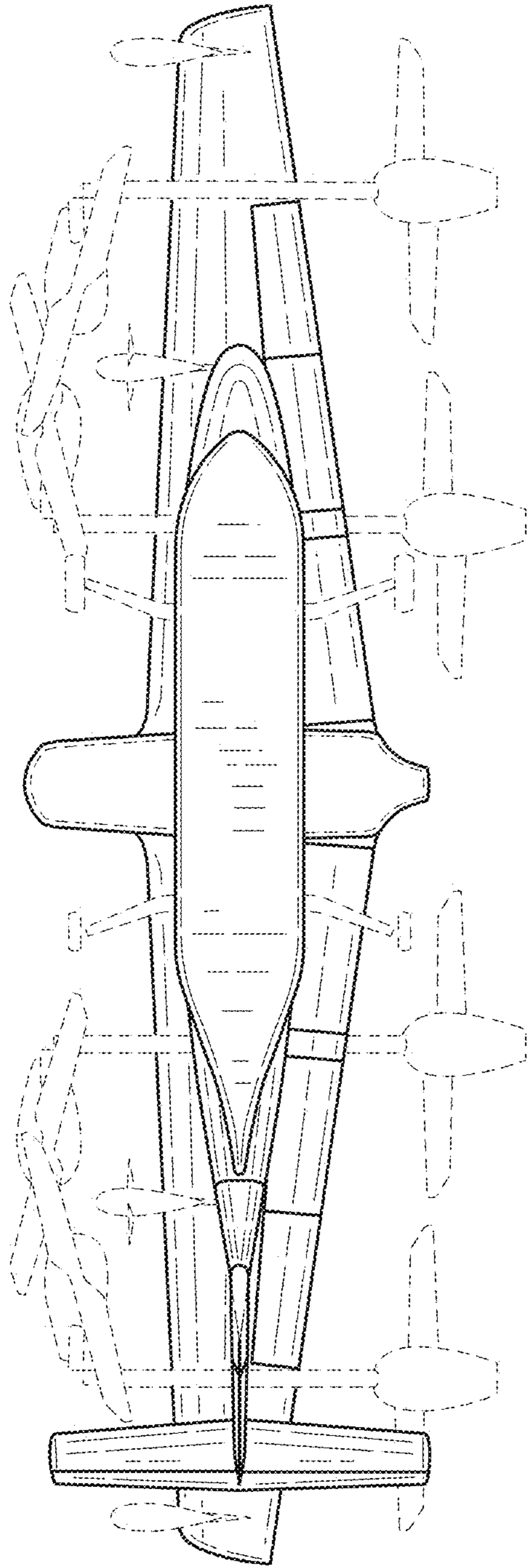

FIG.16