



US00D966144S

(12) **United States Design Patent**
Wang

(10) **Patent No.:** **US D966,144 S**
(45) **Date of Patent:** **** Oct. 11, 2022**

(54) **AERIAL VEHICLE**

FOREIGN PATENT DOCUMENTS

(71) Applicant: **Liming Wang**, Zhang Zhou (CN)

EM 007971817-0001 * 5/2020

(72) Inventor: **Liming Wang**, Zhang Zhou (CN)

OTHER PUBLICATIONS

(**) Term: **15 Years**

Lozenge. "Lozenge HJ38 GPS Drone . . ." Oldest Review: Jan. 11, 2022 [visited: Mar. 8, 2022] Amazon URL: https://www.amazon.com/Lozenge-Quadcopter-Helicopter-Wide-Angle-Photography/dp/B09HDG11PZ/ref=cm_cr_arp_d_product_top?ie=UTF8 (Year: 2022).
Dr Den. "CKRC HJ38 GPS 4K Long Range Drone—Just Released!" Posted: May 11, 2020 [visited: Mar. 4, 2022] Youtube URL: https://www.youtube.com/watch?v=sLfk_qETLto (Year: 2020).*

(21) Appl. No.: **29/735,839**

(22) Filed: **May 25, 2020**

(51) **LOC (13) Cl.** **12-07**

(52) **U.S. Cl.**
USPC **D12/16.1**

(58) **Field of Classification Search**
USPC D12/1-4, 16.1, 214, 319-345;
D21/436-454
CPC B64C 29/0025; B64C 2201/108; B64C
2201/048; B64C 2201/088; B64C 29/00;
B64C 29/0058; B64C 39/001; B64C
39/024; B64C 2201/141; B64C 2201/127;
B64C 2201/128; B64C 2201/042; B64C
2201/143

* cited by examiner

Primary Examiner — John A Voytek

See application file for complete search history.

(57) **CLAIM**

The ornamental design for an aerial vehicle, as shown and described.

DESCRIPTION

FIG. 1 is a front perspective view of an aerial vehicle showing my new design;
FIG. 2 is a rear perspective view thereof;
FIG. 3 is a front elevational view thereof;
FIG. 4 is a rear elevational view thereof;
FIG. 5 is a left side elevational view thereof;
FIG. 6 is a right side elevational view thereof;
FIG. 7 is a top plan view thereof; and,
FIG. 8 is a bottom plan view thereof.
The broken lines in the drawings depict portions of the aerial vehicle that form no part of the claimed design.

(56) **References Cited**

U.S. PATENT DOCUMENTS

D756,842 S	*	5/2016	Ashjaee	D12/16.1
D768,540 S	*	10/2016	Ji	D12/16.1
D783,727 S	*	4/2017	Xiao	D21/441
D784,201 S	*	4/2017	Goldy	D21/441
D798,962 S	*	10/2017	Xiao	D21/441
D858,353 S	*	9/2019	Gan	D12/16.1
D873,175 S	*	1/2020	Li	D12/328
D874,338 S	*	2/2020	Zhao	D21/436
D887,340 S	*	6/2020	He	D12/328
D891,298 S	*	7/2020	Zhao	D12/16.1
D944,118 S	*	2/2022	Lin	D12/16.1
2020/0086982 A1	*	3/2020	Wang	B64C 39/024

1 Claim, 8 Drawing Sheets

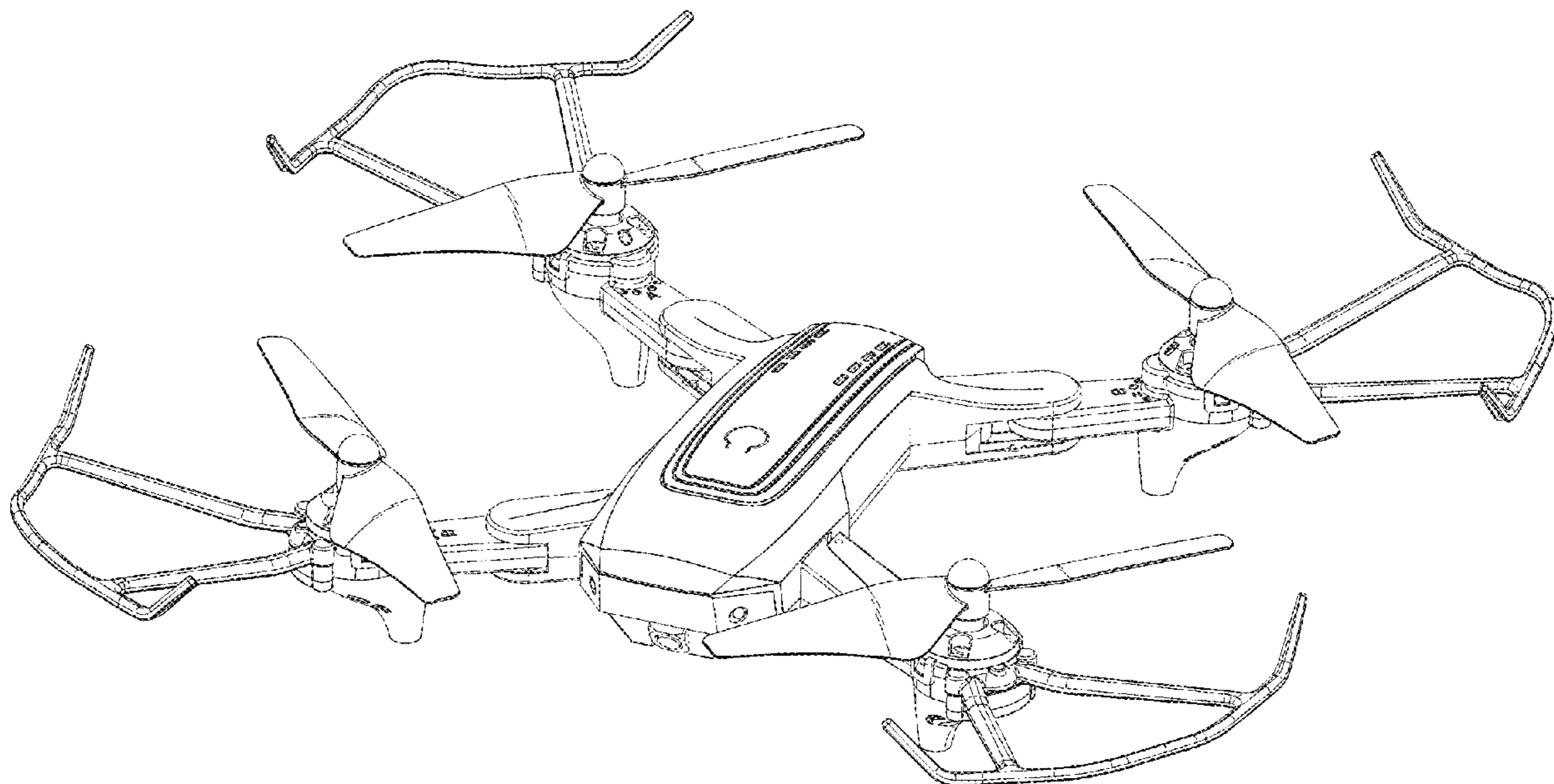

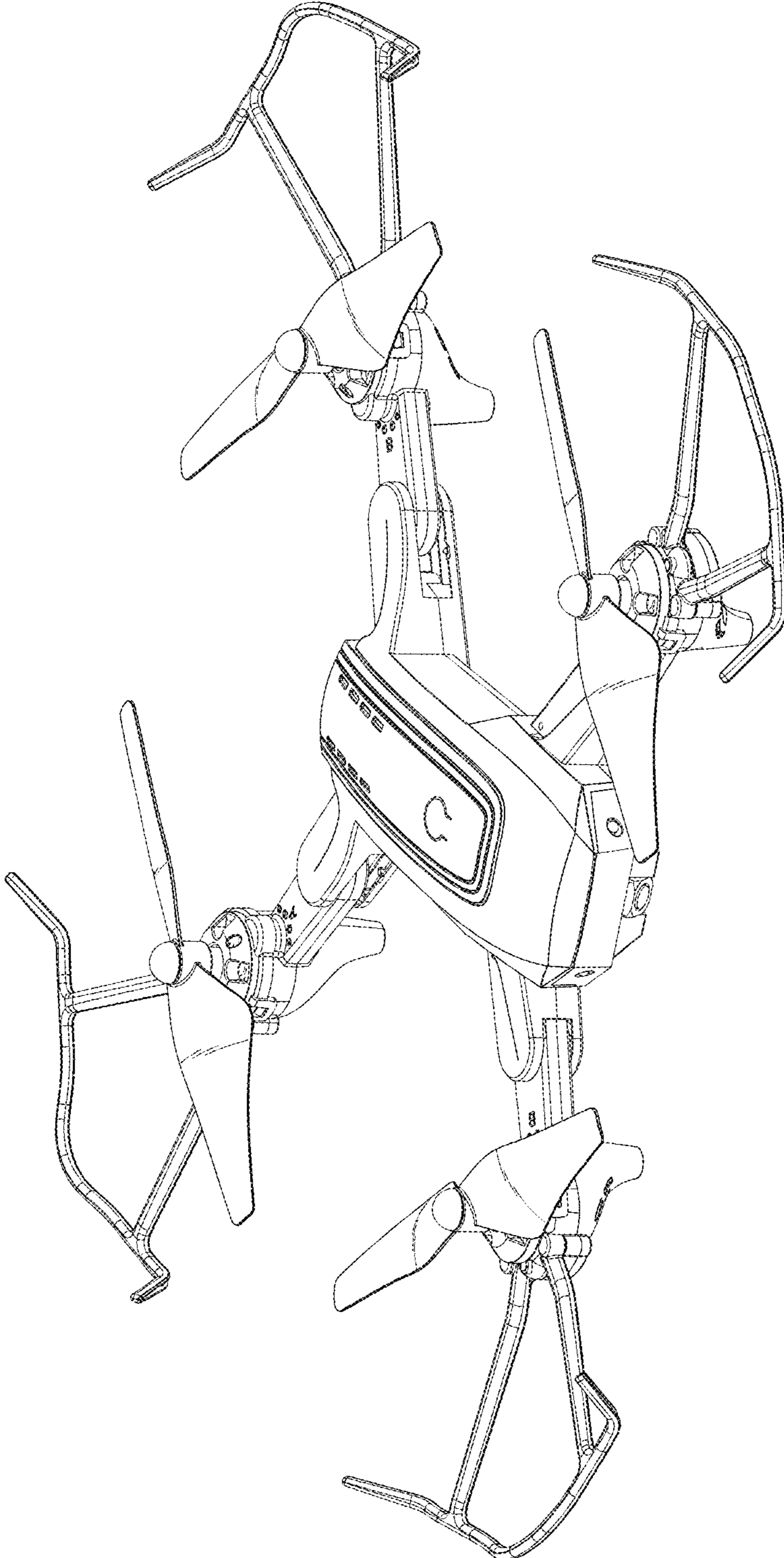

FIG.1

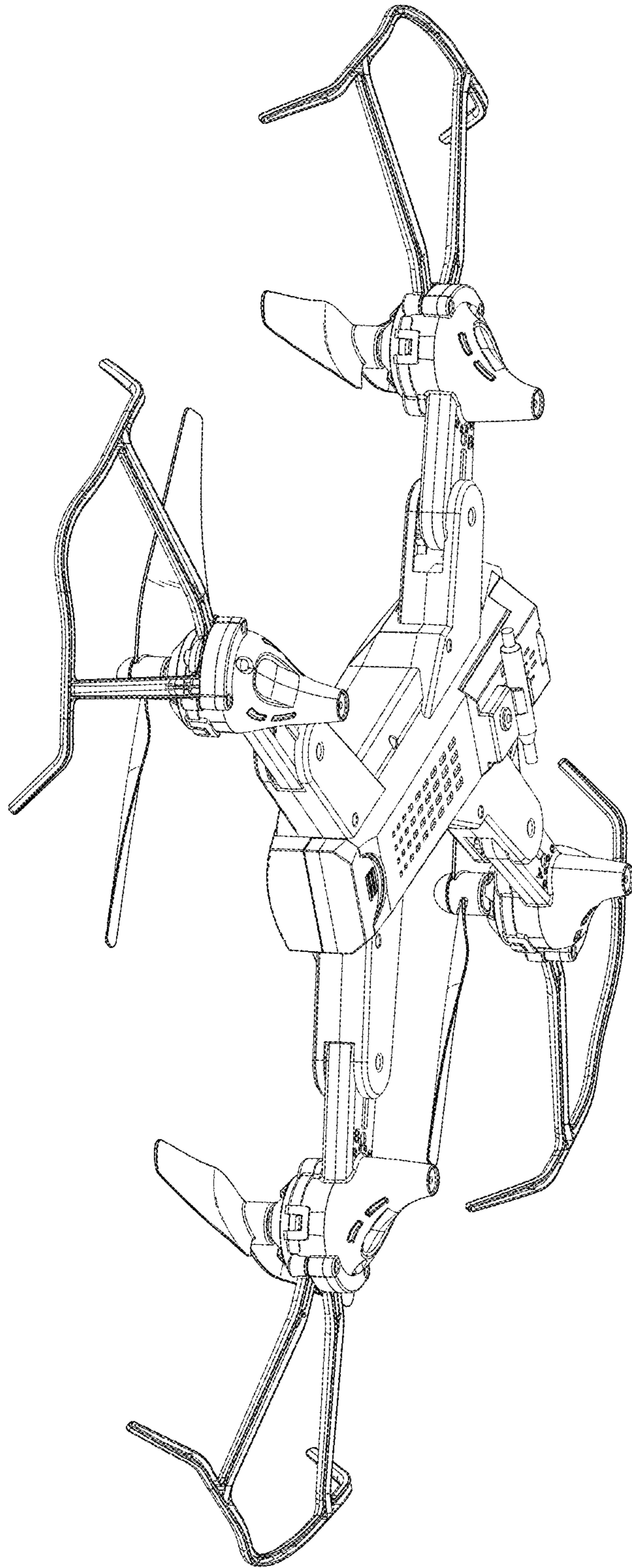

FIG.2

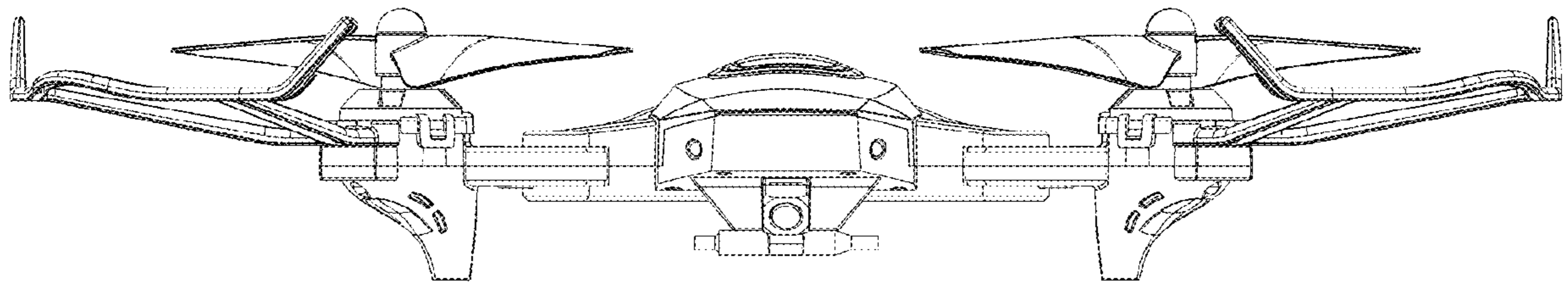

FIG.3

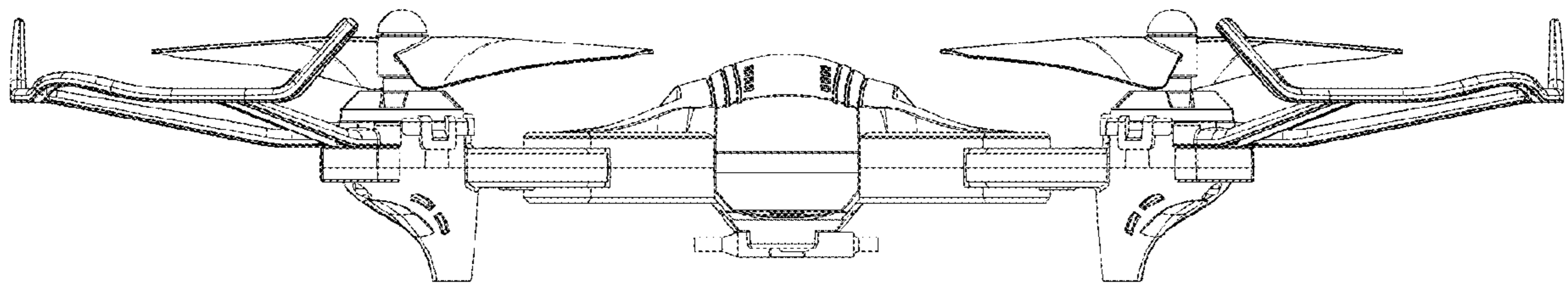

FIG.4

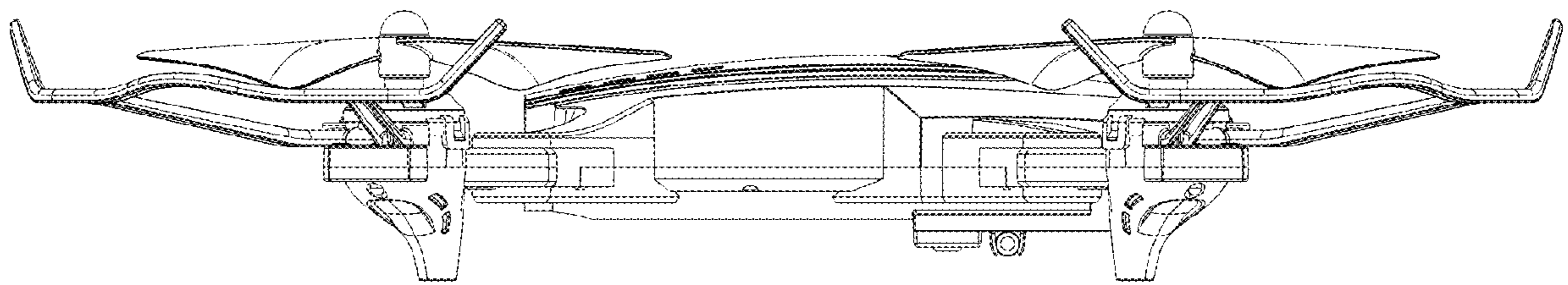

FIG.5

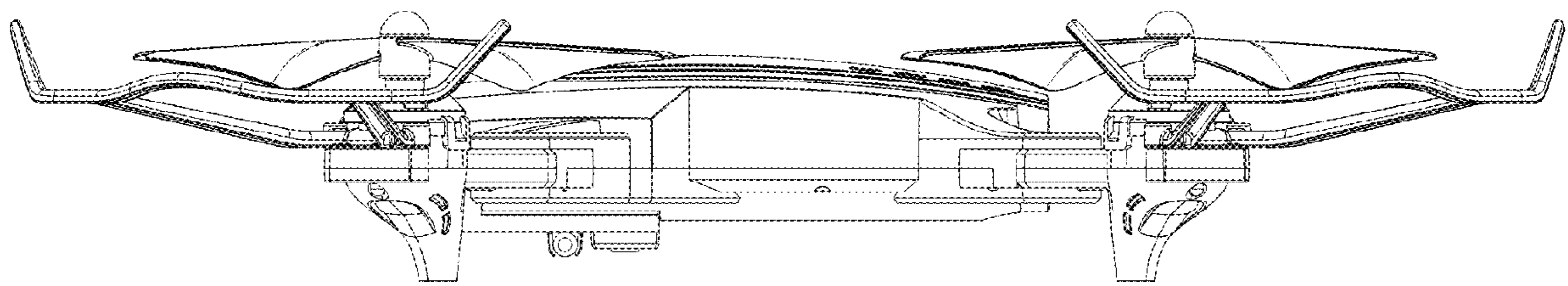

FIG.6

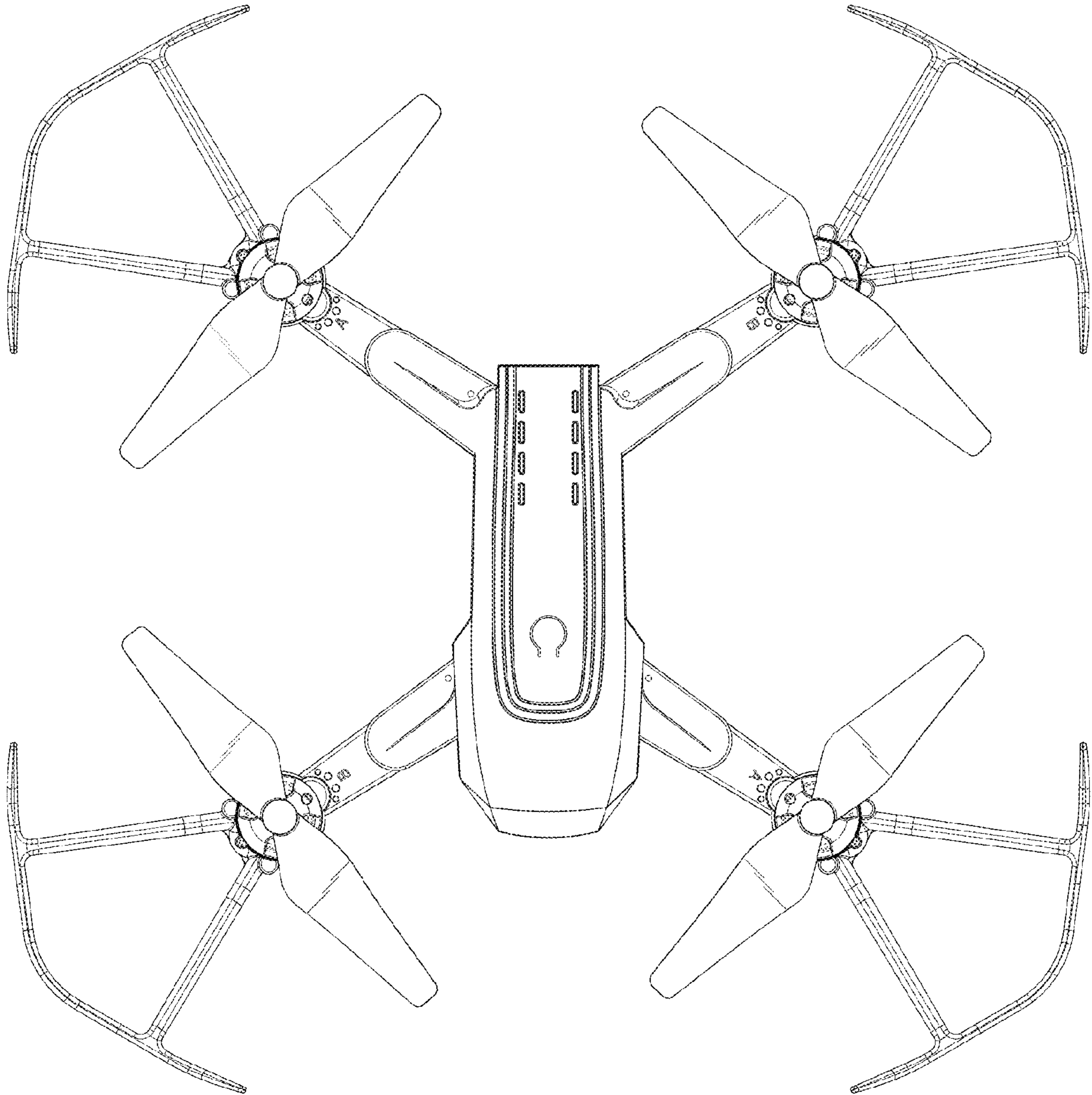

FIG.7

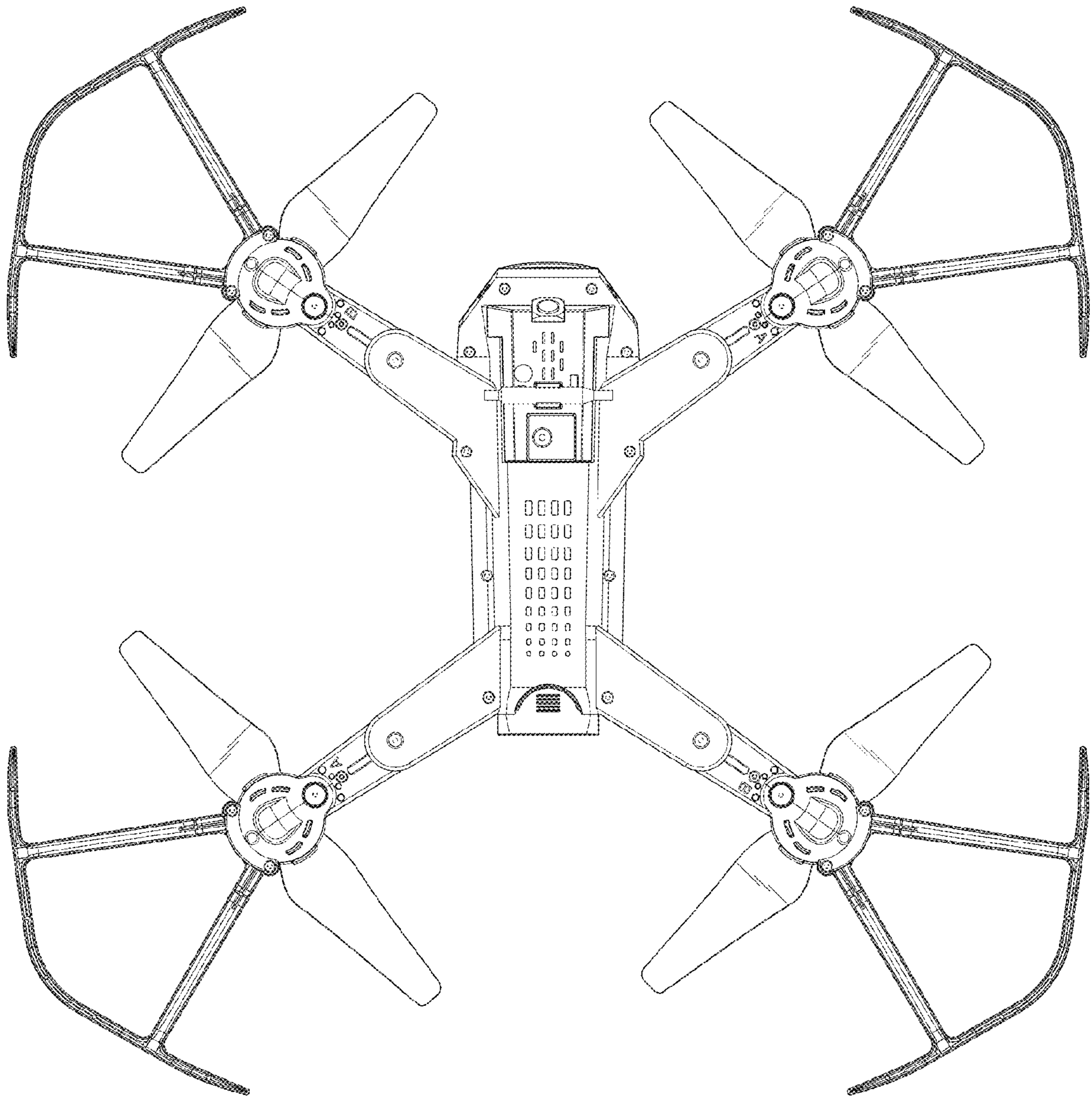

FIG.8