



US00D965542S

(12) **United States Design Patent**
Fujii

(10) **Patent No.:** **US D965,542 S**
(45) **Date of Patent:** **** Oct. 4, 2022**

(54) **BOAT OF SUBSTRATE PROCESSING APPARATUS**

(71) Applicant: **KOKUSAI ELECTRIC CORPORATION**, Tokyo (JP)

(72) Inventor: **Satoshi Fujii**, Toyama (JP)

(73) Assignee: **KOKUSAI ELECTRIC CORPORATION**, Tokyo (JP)

(**) Term: **15 Years**

(21) Appl. No.: **29/750,438**

(22) Filed: **Sep. 14, 2020**

(30) **Foreign Application Priority Data**

Mar. 19, 2020 (JP) 2020-005341 D

(51) **LOC (13) Cl.** **13-03**

(52) **U.S. Cl.**
USPC **D13/182**

(58) **Field of Classification Search**
USPC D10/8; D13/182; D16/230-234;
D24/108, 164, 169, 170, 233; D26/27
(Continued)

(56) **References Cited**

U.S. PATENT DOCUMENTS

D655,255 S * 3/2012 Takebayashi D13/182
D734,730 S * 7/2015 Yoshida D13/182
(Continued)

FOREIGN PATENT DOCUMENTS

JP 1640260 S 9/2019

Primary Examiner — Patricia A Palasik

(74) *Attorney, Agent, or Firm* — Fitch, Even, Tabin & Flannery, LLP

(57) **CLAIM**

The ornamental design for a boat of substrate processing apparatus, as shown and described.

DESCRIPTION

FIG. 1 is a front, top and right side perspective view of a boat of substrate processing apparatus showing our new design; FIG. 2 is a front elevational view thereof; FIG. 3 is a rear elevational view thereof; FIG. 4 is a left side elevational view thereof; FIG. 5 is a right side elevational view thereof; FIG. 6 is a top plan view thereof; FIG. 7 is a bottom plan view thereof; FIG. 8 is an enlarged portion view taken along line 8-8 in FIG. 2 thereof; FIG. 9 is an enlarged portion view taken along line 9-9 in FIG. 2 thereof; FIG. 10 is an enlarged portion view taken along line 10-10 in FIG. 2 thereof; FIG. 11 is an enlarged perspective view of the claimed portion indicated by the solid line FIG. 8 thereof; FIG. 12 is an enlarged front elevational view of the claimed portion indicated by the solid line in FIG. 8 thereof; FIG. 13 is an enlarged left side elevational view of the claimed portion indicated by the solid line in FIG. 8 thereof; FIG. 14 is an enlarged right side elevational view of the claimed portion indicated by the solid line in FIG. 8 thereof; FIG. 15 is an enlarged top plan view of the claimed portion indicated by the solid line in FIG. 8 thereof; FIG. 16 is an enlarged bottom plan elevational view of the claimed portion indicated by the solid line in FIG. 8 thereof; and, FIG. 17 is an enlarged rear elevational view of the claimed portion indicated by the solid line in FIG. 8. The dashed-dot-dashed lines represent the boundary lines of the claimed design. The broken lines are included for the purpose of illustrating portions of the article that form no part of the claimed design.

1 Claim, 11 Drawing Sheets

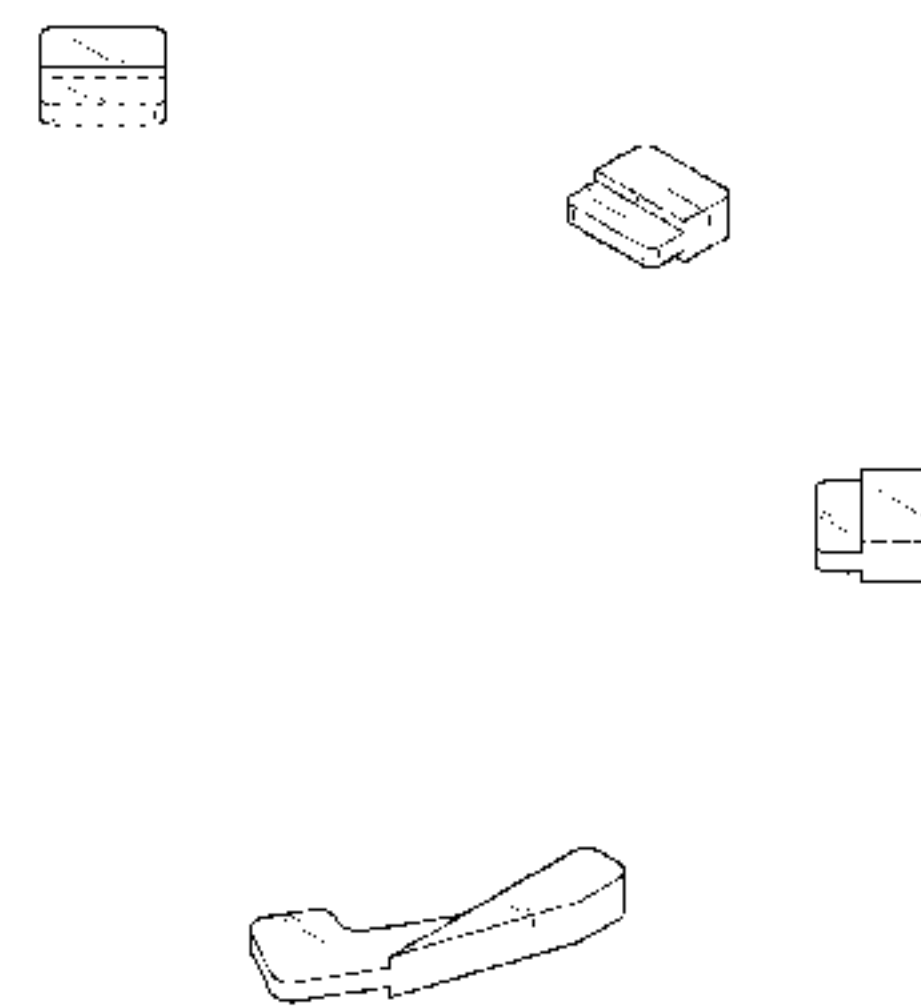
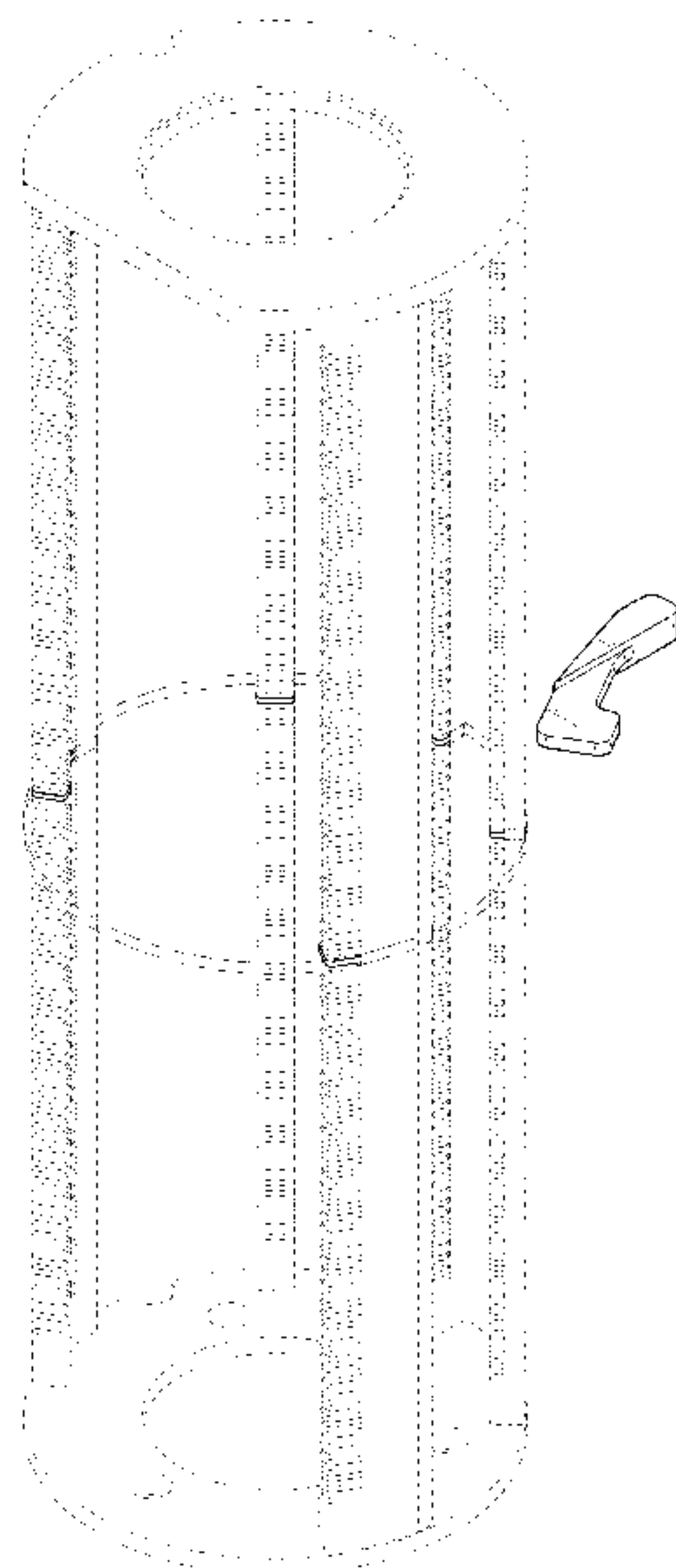

(58) **Field of Classification Search**

CPC . H01L 21/00; H01L 21/67; B65C 2009/0043;
B65C 2009/1846; B23K 26/00; B23K
26/0006; B23K 26/0096; B23K 26/08;
B23K 26/36; B23K 26/32; B23K 26/40;
H01S 5/00; H01S 5/02; H01S 5/04; H01S
5/10

See application file for complete search history.

(56) **References Cited**

U.S. PATENT DOCUMENTS

D737,785 S * 9/2015 Yoshida D13/182
D738,329 S * 9/2015 Yoshida D13/182
D739,831 S * 9/2015 Takagi D13/182
D740,769 S * 10/2015 Takagi D13/182
D747,279 S * 1/2016 Yoshida D13/182
D769,201 S * 10/2016 Kusakabe D13/182
D772,183 S * 11/2016 Kusakabe D13/182
D789,310 S * 6/2017 Kusakabe D13/182
D791,721 S * 7/2017 Kusakabe D13/182
D839,219 S * 1/2019 Yoshida D13/182
D846,514 S * 4/2019 Yoshida D13/182
D847,105 S * 4/2019 Okajima D13/182
D893,438 S * 8/2020 Hasegawa D13/182
D920,935 S * 6/2021 Sambu D13/182
D940,669 S * 1/2022 Sambu D13/182
2013/0284683 A1 * 10/2013 Jdira H01L 21/67309
211/41.18
2016/0093487 A1 * 3/2016 Huussen H01L 21/67303
438/758

* cited by examiner

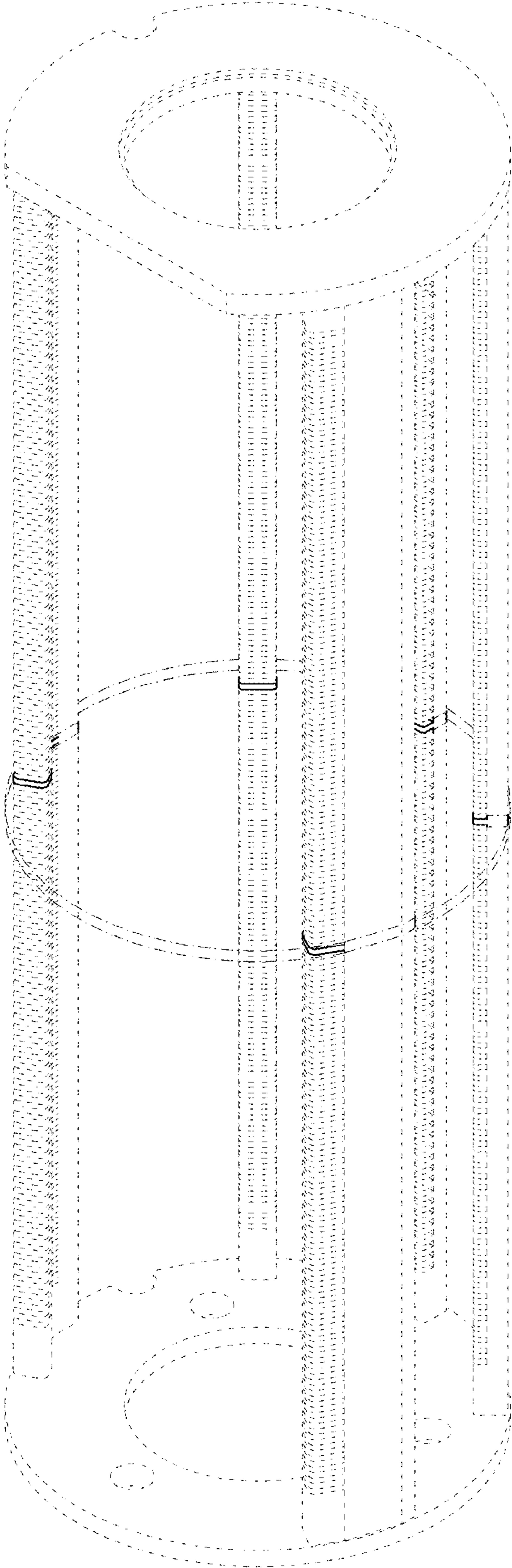

FIG. 1

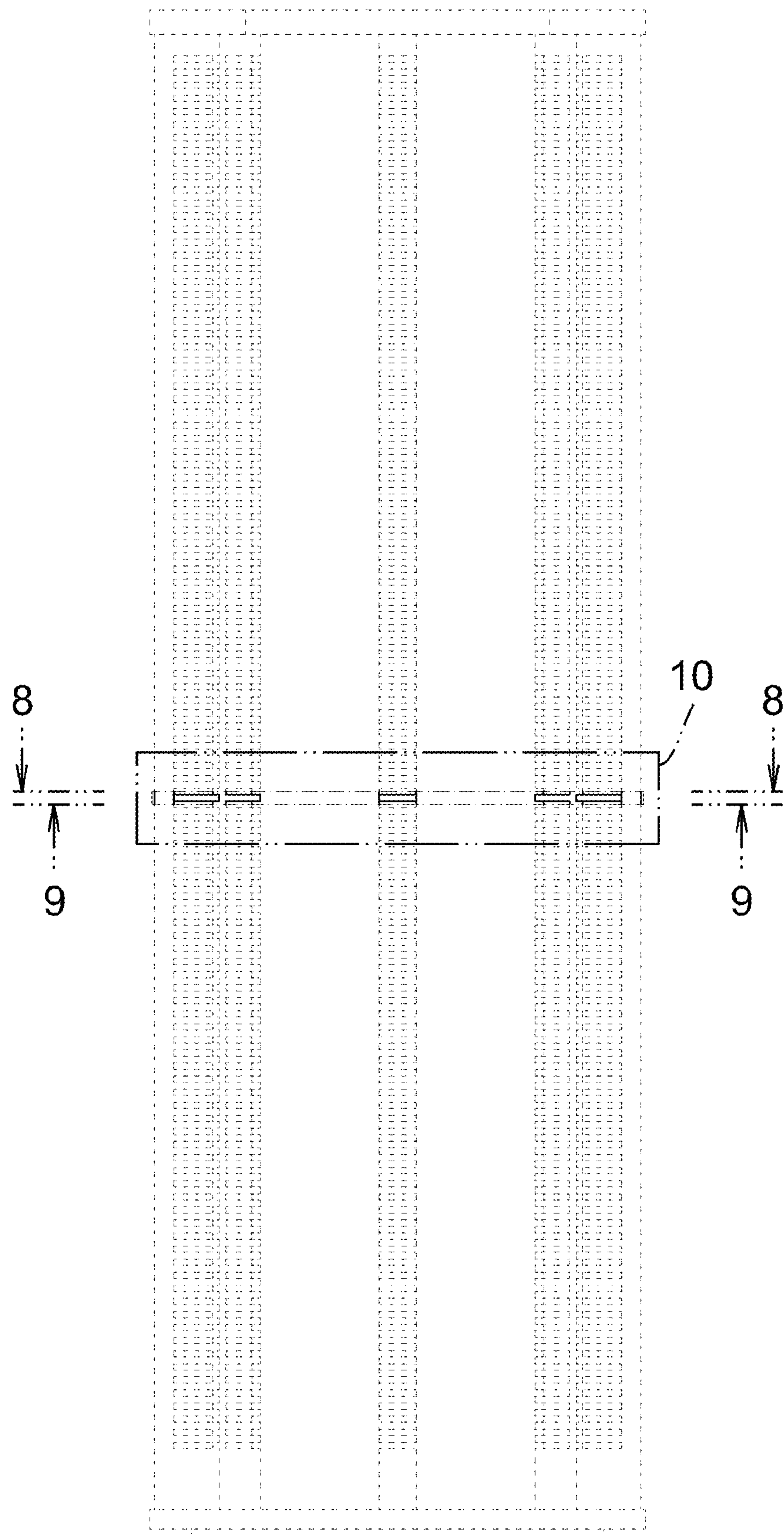

FIG. 2

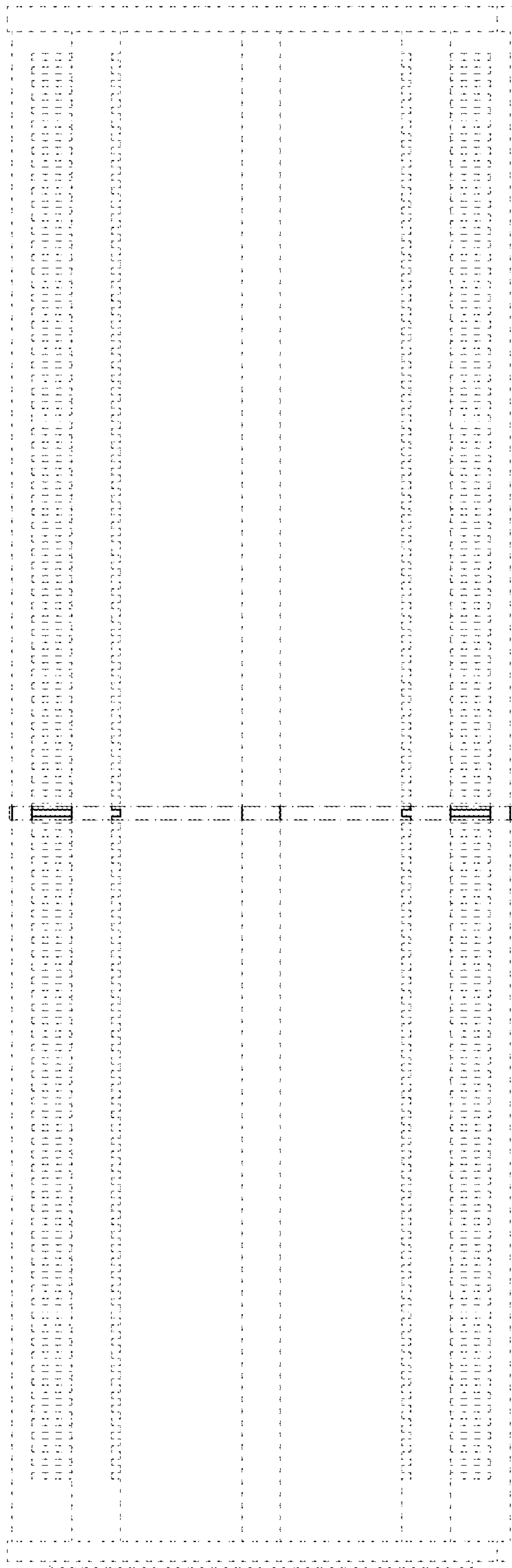

FIG. 3

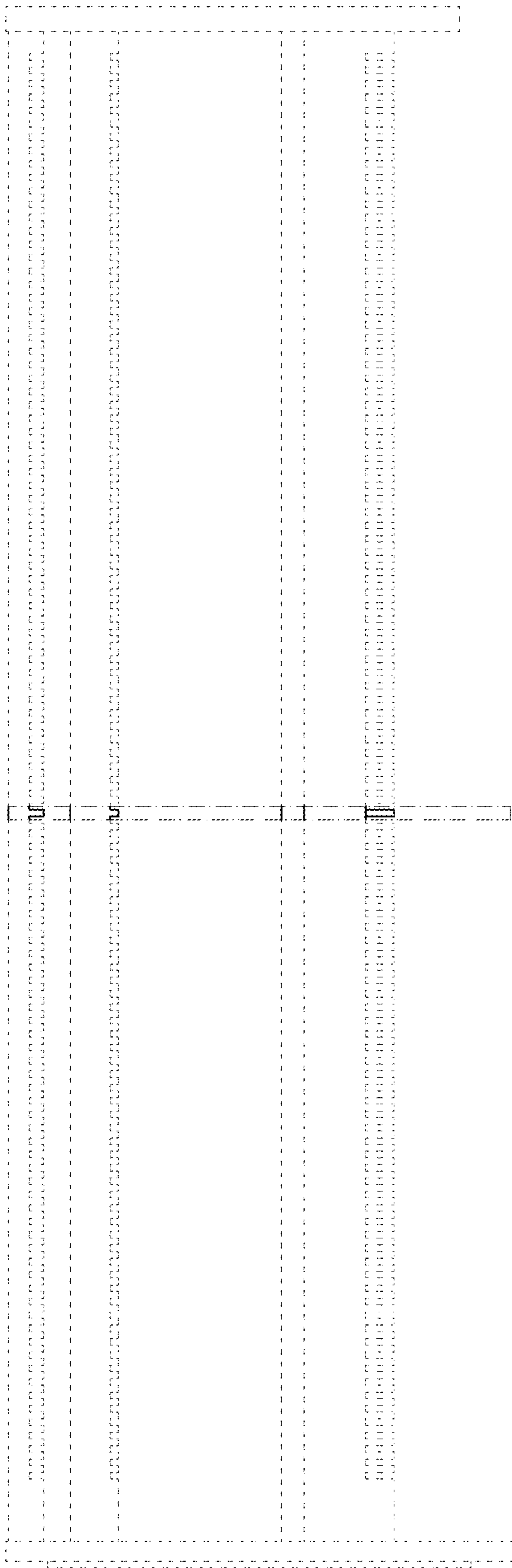

FIG. 4

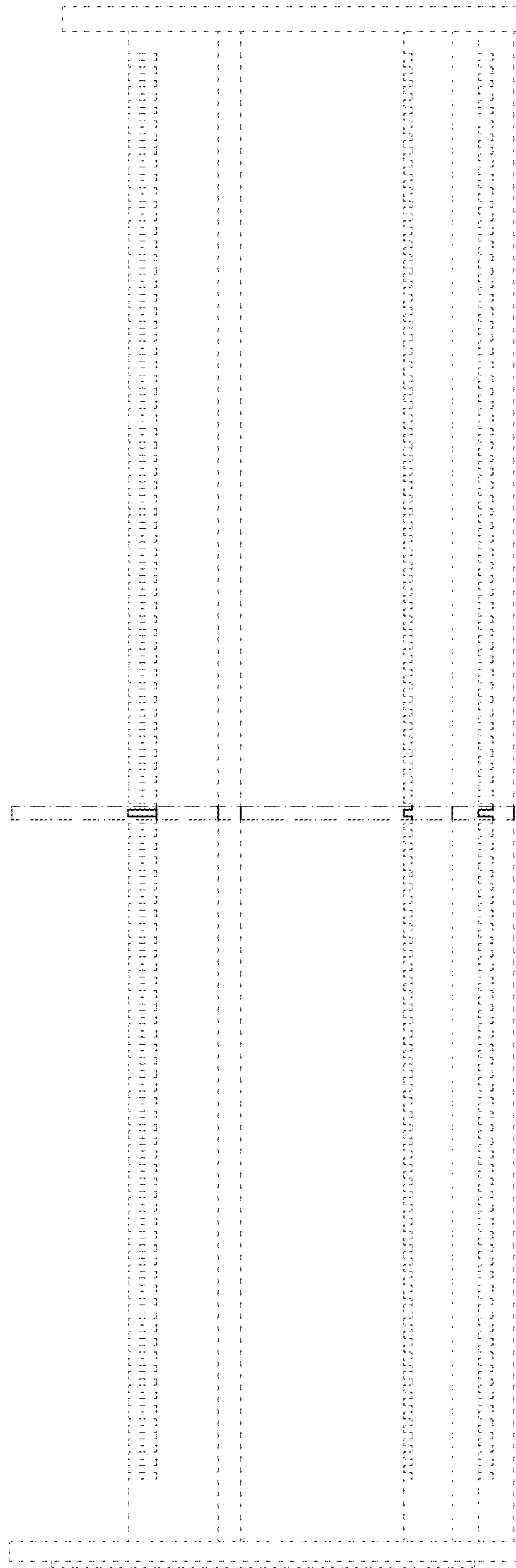

FIG. 5

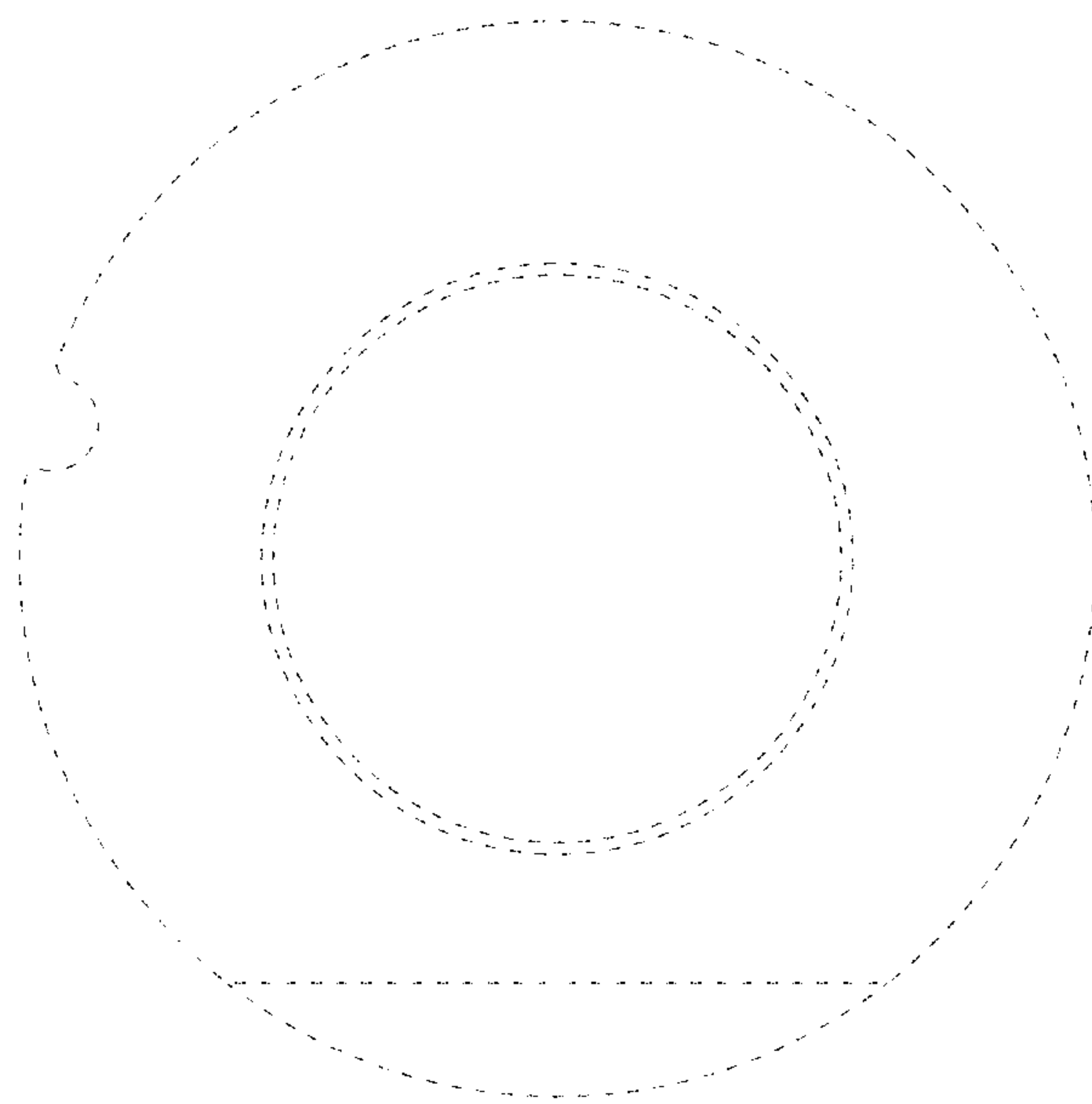

FIG. 6

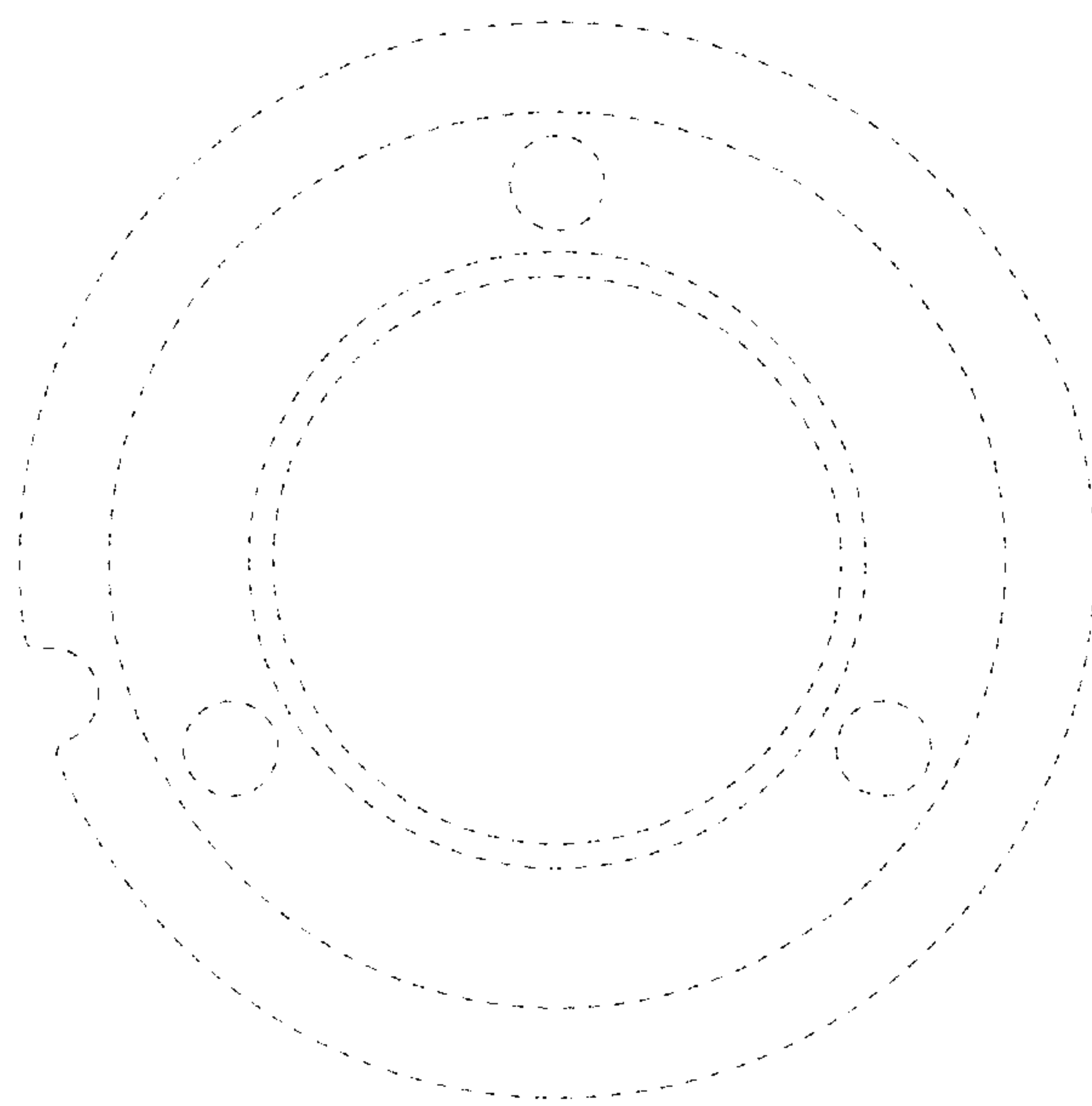

FIG. 7

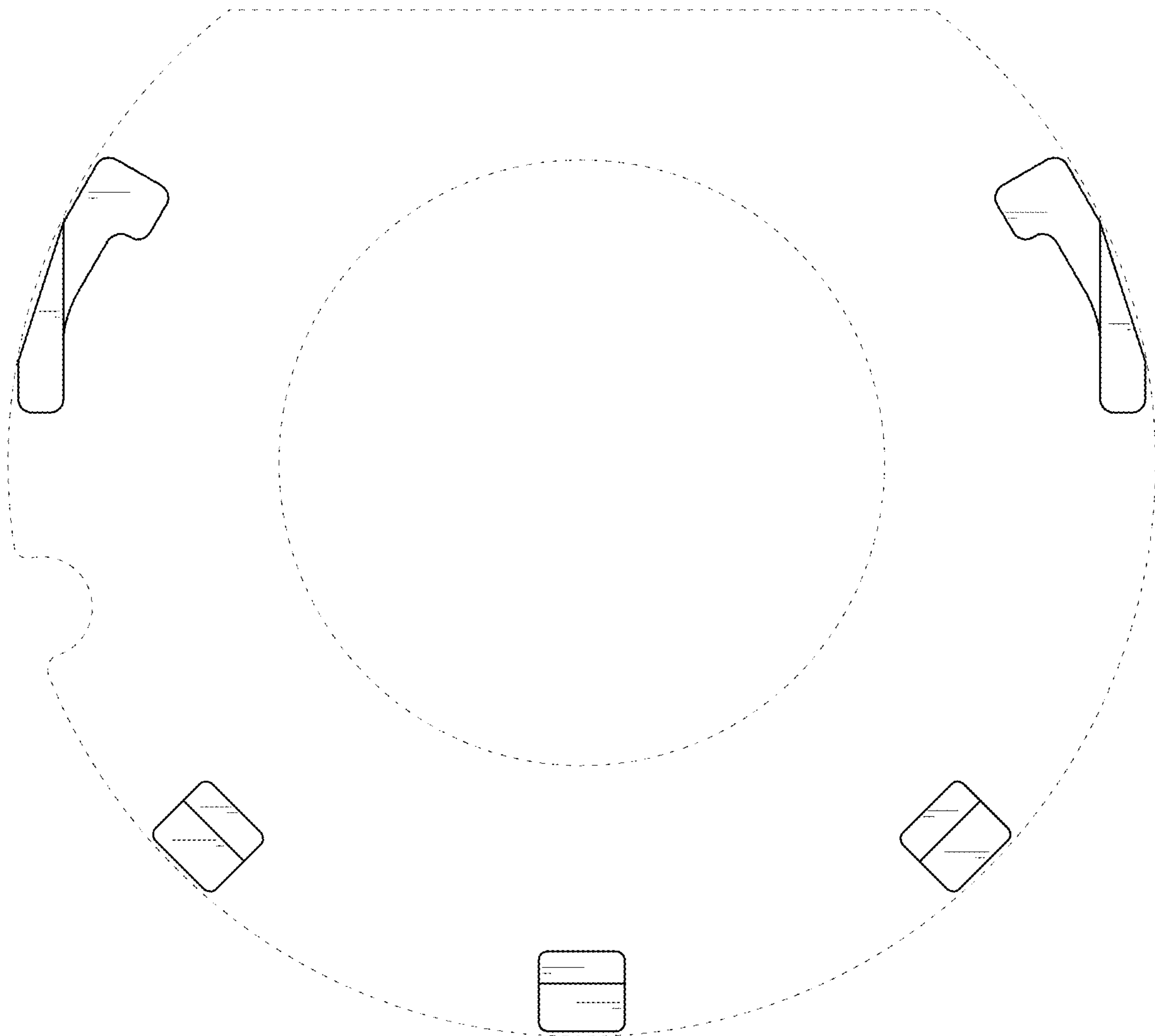

FIG. 8

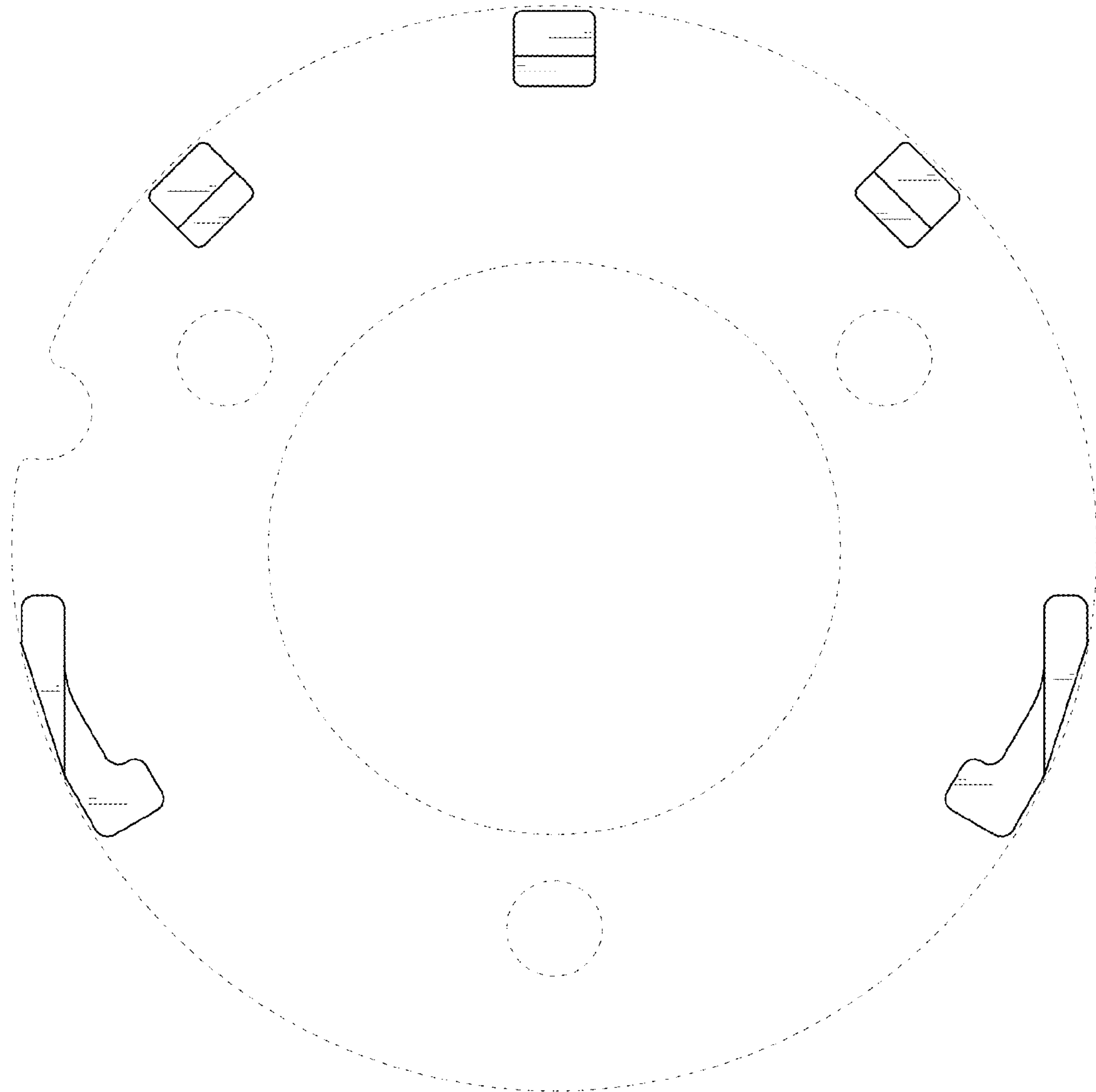

FIG. 9

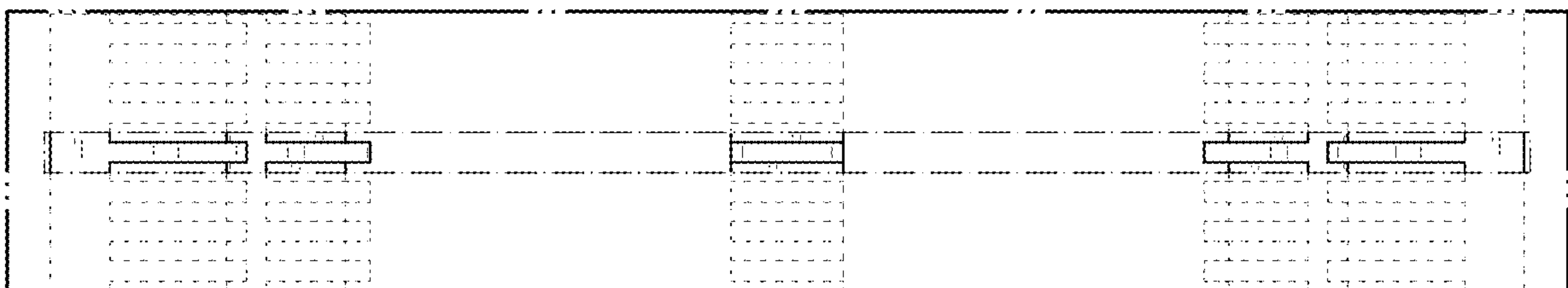

FIG. 10

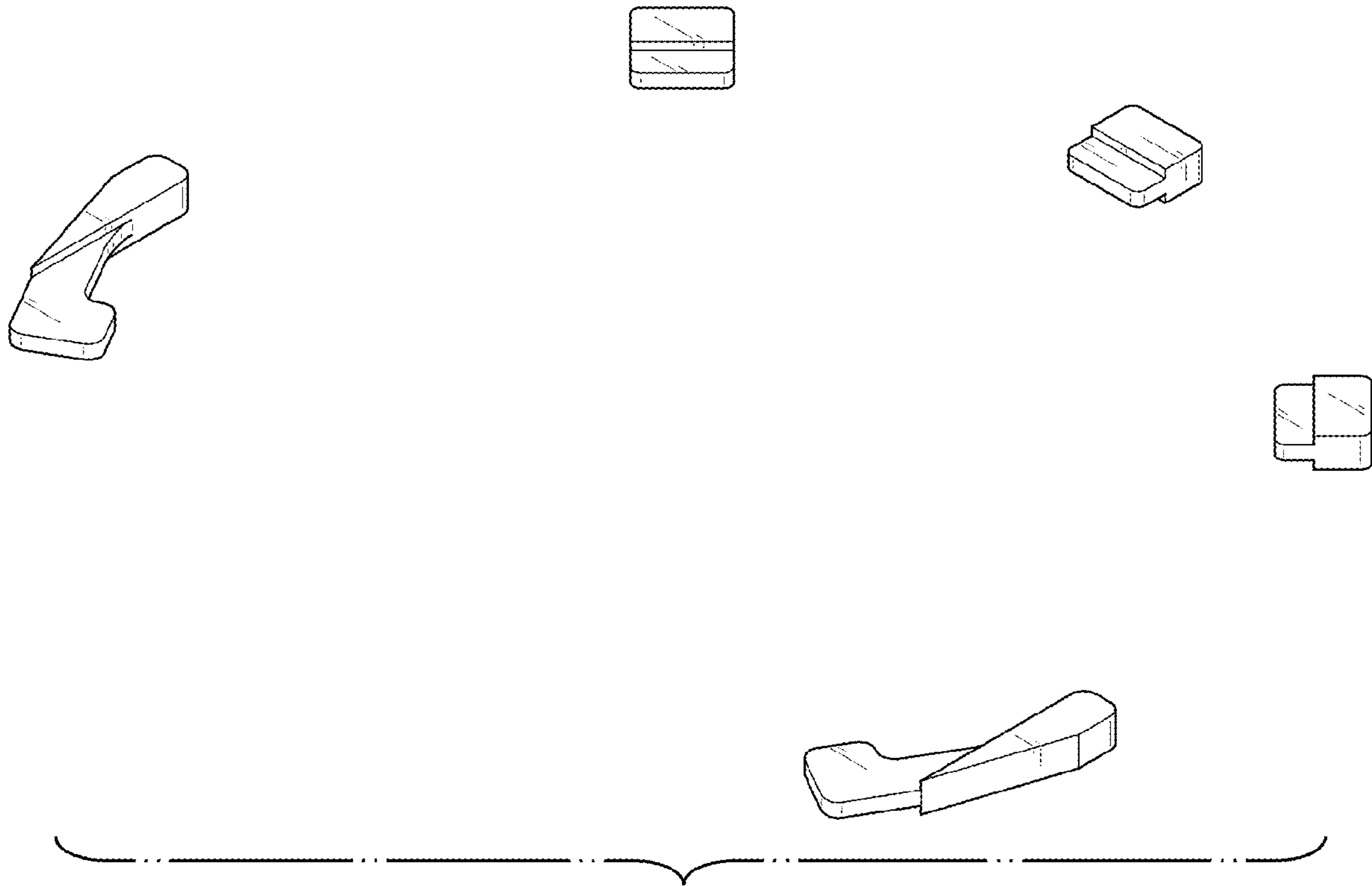

FIG. 11

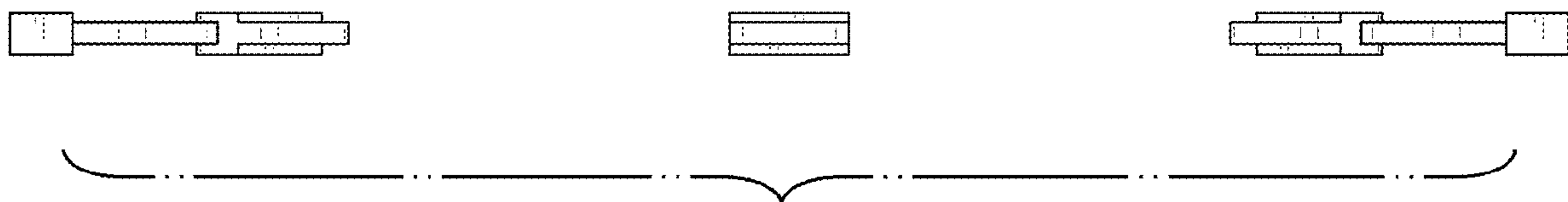

FIG. 12

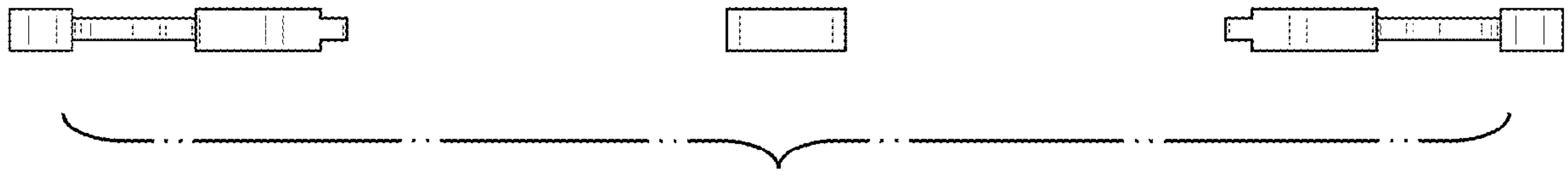

FIG. 13



FIG. 14



FIG. 15

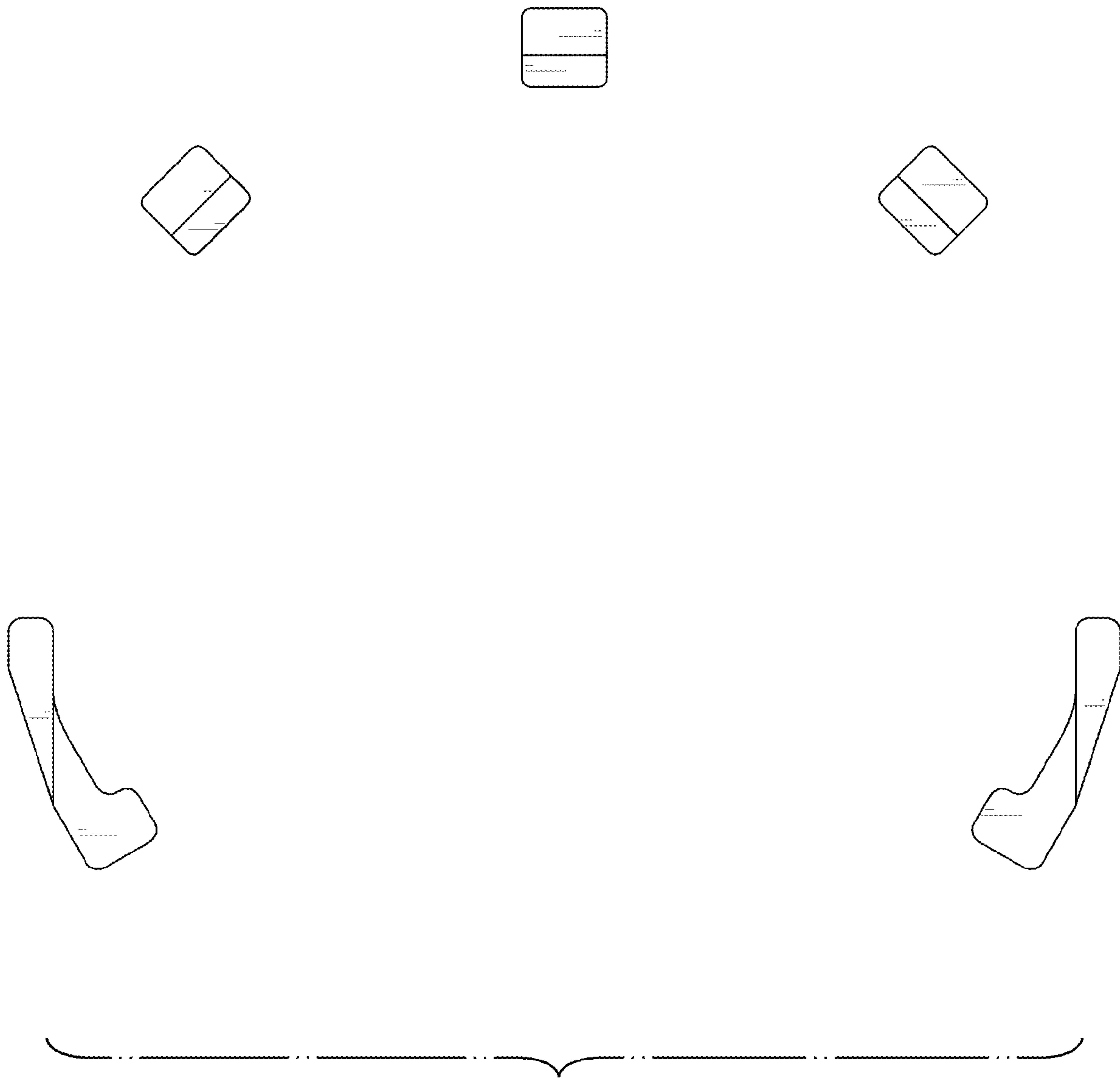

FIG. 16

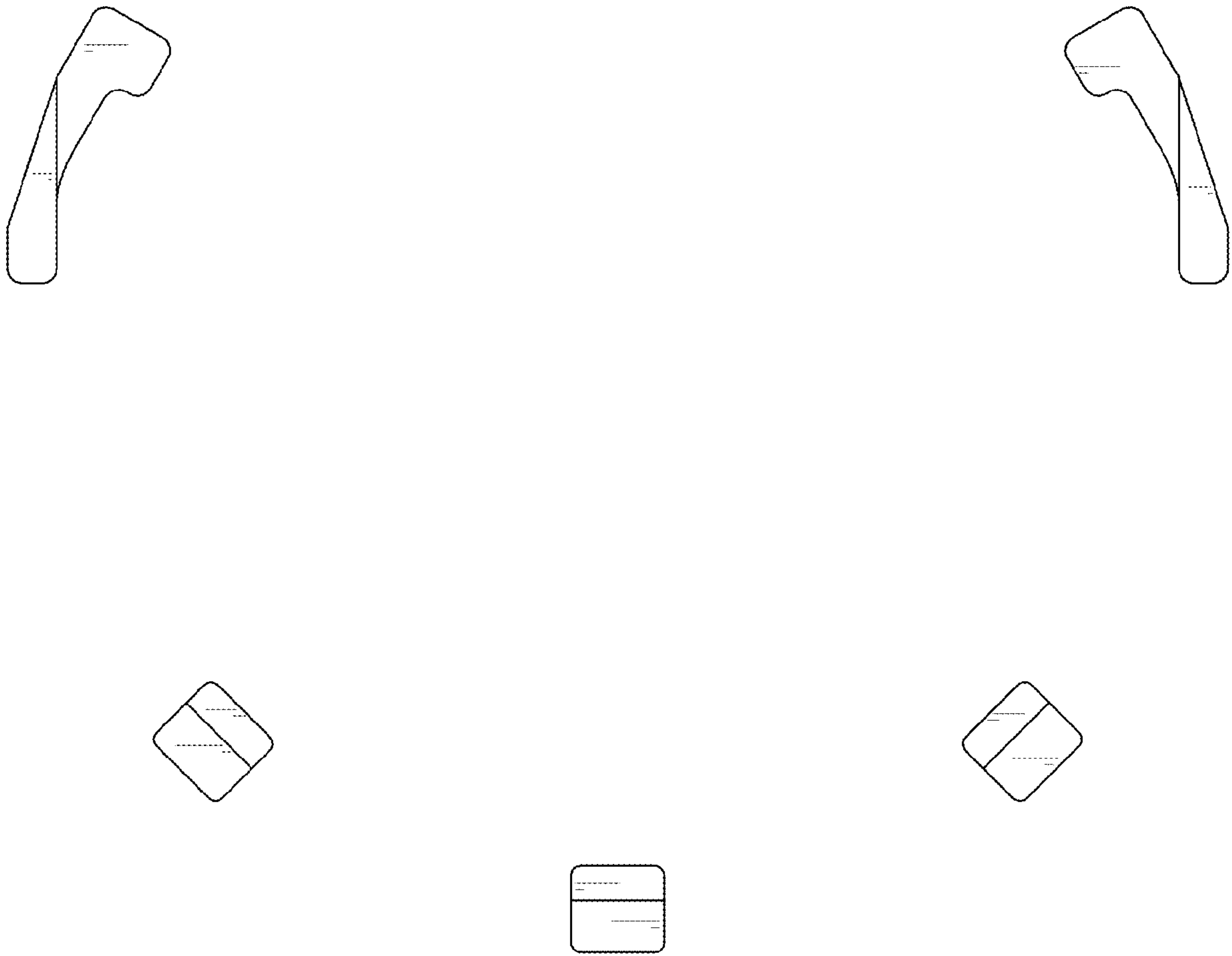

FIG. 17