



US00D965535S

(12) **United States Design Patent**
Pedoeem et al.

(10) **Patent No.:** **US D965,535 S**

(45) **Date of Patent:** **** Oct. 4, 2022**

(54) **FLIPTOP LID**

(71) Applicant: **Crestron Electronics, Inc.**, Rockleigh, NJ (US)

(72) Inventors: **Albert Pedoeem**, West Orange, NJ (US); **David Paolazzi**, North Arlington, NJ (US)

(73) Assignee: **Crestron Electronics, Inc.**, Rockleigh, NJ (US)

(**) Term: **15 Years**

(21) Appl. No.: **29/822,860**

(22) Filed: **Jan. 12, 2022**

Related U.S. Application Data

(63) Continuation-in-part of application No. 29/754,069, filed on Oct. 6, 2020, which is a continuation of application No. 16/864,923, filed on May 1, 2020, now Pat. No. 11,355,907.

(51) **LOC (13) Cl.** **13-03**

(52) **U.S. Cl.**
USPC **D13/156**

(58) **Field of Classification Search**

USPC D13/107, 108, 110, 137.1, 137.2, 137, 3, D13/137.4, 138.1, 138.2, 139.1, 139.2, D13/139.3, 139.4, 139.5, 139.6, 139.7, D13/139.8, 146, 151, 152, 153, 154, 158, D13/159, 160, 161, 162, 162.1, 163, 164, D13/165, 166, 167, 168, 169, 171, 172, D13/173, 174, 175, 176, 177, 178, 179, D13/184, 199, 156
CPC H01R 13/00; H01R 13/03; H01R 13/04; H01R 13/10; H01R 13/35; H01R 13/44; H01R 13/46; H01R 13/453; H01R 13/4534; H01R 13/502; H01R 13/506; H01R 13/514; H01R 13/518; H01R 13/6272; H01R 13/631; H01R 13/639; H01R 13/652; H01R 13/665; H01R 13/6633; H01R 13/6666; H01R 13/6675; H01R 13/7135; H01R 31/02; H01R

31/06; H01R 31/065; H01R 25/00; H01R 25/006; H01R 9/00; H01R 11/00; H01R 35/04; H01R 2201/06; H01H 2207/00; H01H 2207/022; H01H 2203/00; H05K 5/00; H05K 5/03; H02G 3/088

See application file for complete search history.

(56) **References Cited**

U.S. PATENT DOCUMENTS

6,046,405	A	4/2000	Obermann et al.	
6,162,071	A	12/2000	Muller	
D465,201	S	11/2002	Gershfeld	
D472,213	S *	3/2003	Byrne	D13/139.4
D473,525	S *	4/2003	Pincek	D13/162
6,802,577	B2	10/2004	Gershfeld	
D513,493	S	1/2006	Feldstein et al.	
D526,961	S *	8/2006	Kissinger	D13/139.4
D556,139	S *	11/2007	Gershfeld	D13/139.4
7,312,393	B2	12/2007	McCarthy et al.	
D569,863	S	5/2008	Feldstein et al.	
7,667,145	B2	2/2010	Dinh et al.	
D626,069	S *	10/2010	Byrne	D13/139.4
D626,542	S	11/2010	Libman et al.	
D628,097	S	11/2010	Libman et al.	
D628,098	S	11/2010	Libman et al.	
D628,099	S	11/2010	Libman et al.	
D638,314	S	5/2011	Libman et al.	
D638,315	S	5/2011	Libman et al.	
D639,680	S	6/2011	Libman et al.	
D639,681	S	6/2011	Rodriguez et al.	
D640,577	S	6/2011	Libman et al.	
D640,939	S	7/2011	Libman et al.	
D640,940	S	7/2011	Libman et al.	
7,989,710	B2	8/2011	Hansen et al.	
D657,315	S	4/2012	Feldstein et al.	
D664,050	S	7/2012	Rodriguez et al.	
D665,355	S *	8/2012	Byrne	D13/139.4
D678,786	S	3/2013	Rodriguez et al.	
8,469,303	B2	6/2013	Feldstein et al.	
8,469,304	B2	6/2013	Feldstein et al.	
8,469,305	B2	6/2013	Feldstein et al.	
D686,992	S	7/2013	Eisen	
8,896,656	B2	11/2014	Epstein et al.	
8,943,978	B2	2/2015	Soper et al.	
9,056,744	B2	6/2015	Feldstein et al.	
D734,729	S	7/2015	Chaloupecky et al.	
9,257,776	B2	2/2016	Kramer	
D759,596	S *	6/2016	Byrne	D13/137.2
9,407,033	B2 *	8/2016	Kong	H01R 13/5227
9,475,673	B2	10/2016	Feldstein et al.	

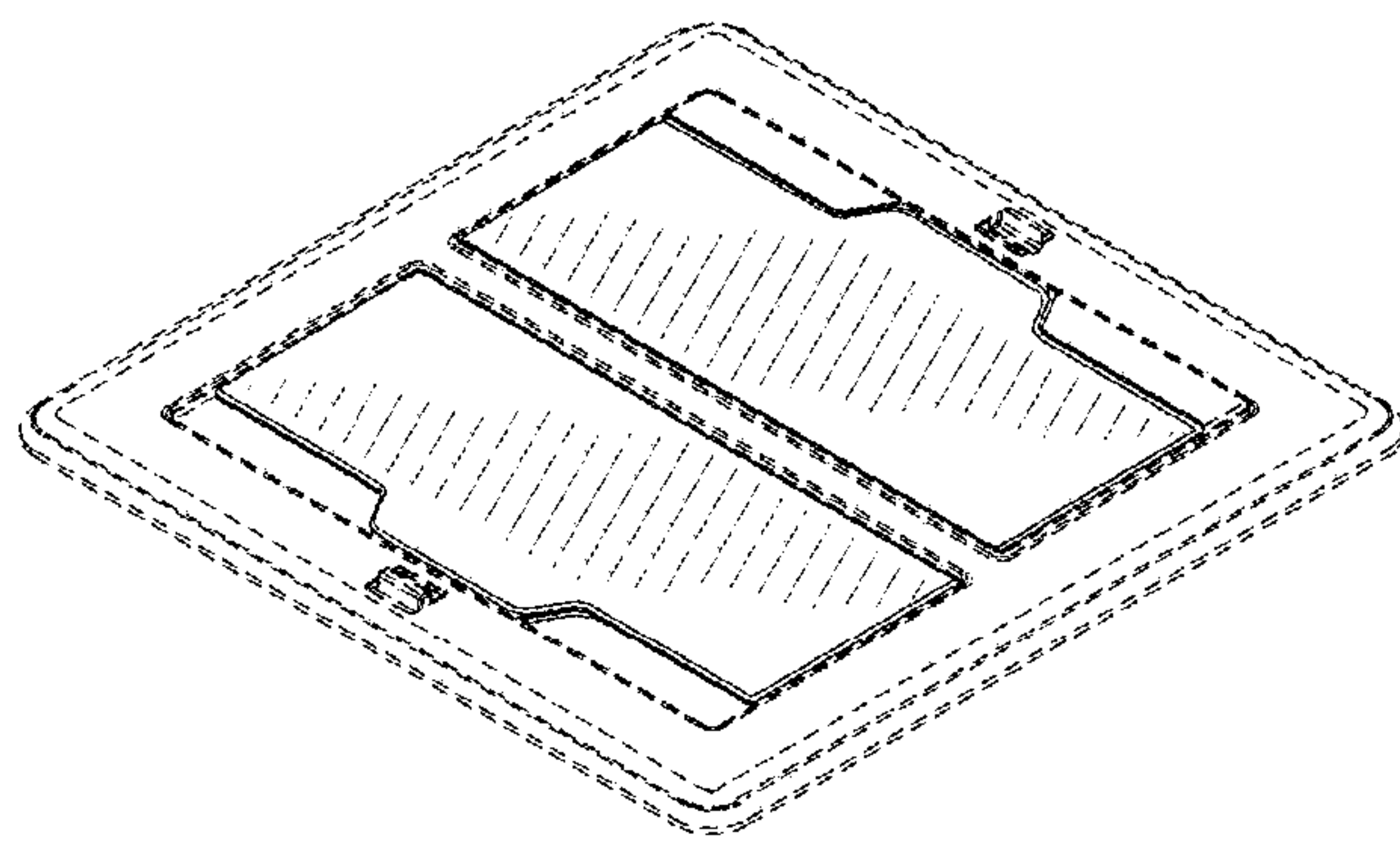
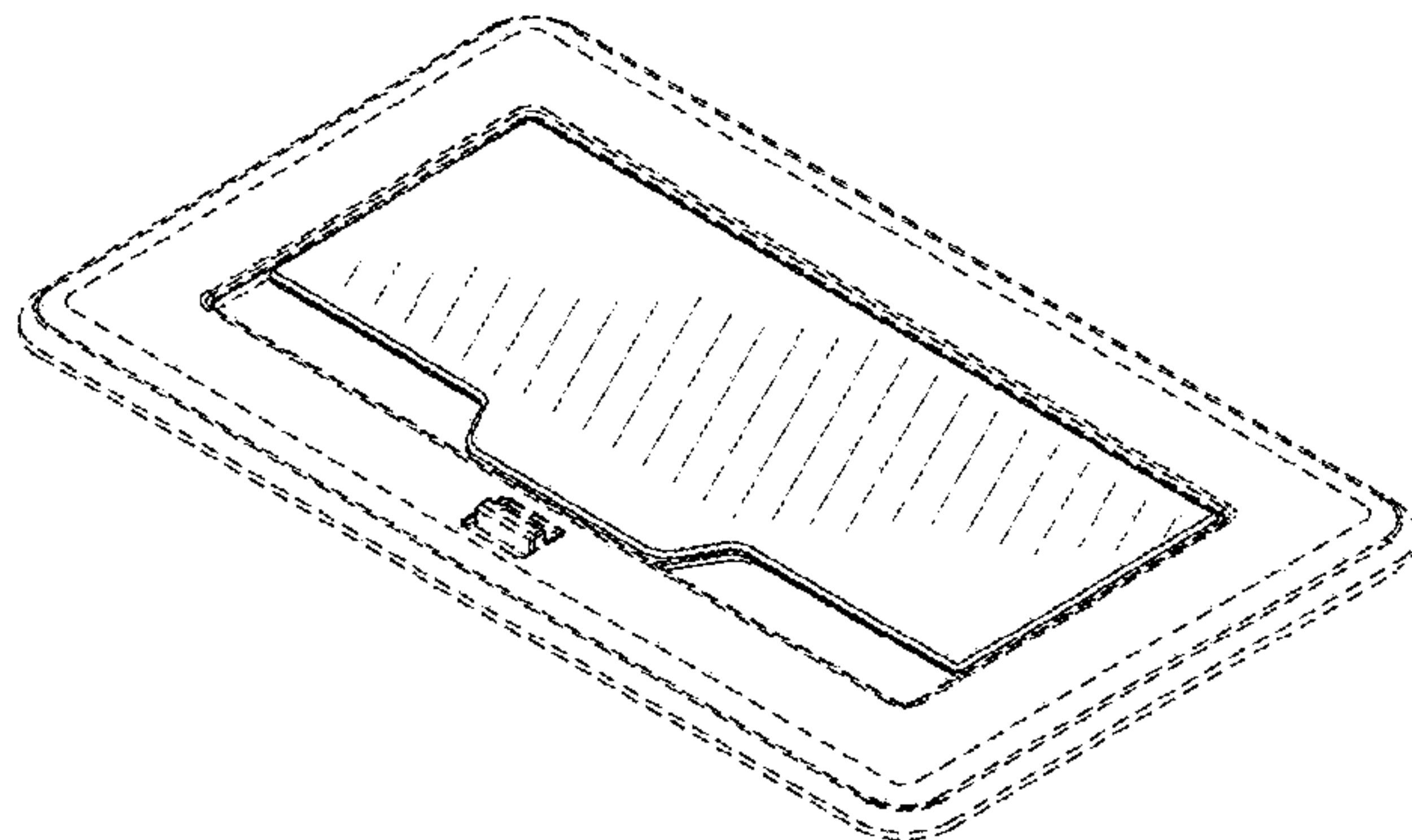

D775,080	S	12/2016	Newhouse	
9,706,833	B2	7/2017	Newhouse et al.	
D801,285	S	10/2017	Timmins et al.	
D811,337	S *	2/2018	Byrne	D13/137.2
D858,450	S *	9/2019	Jhun	D14/134
D858,451	S *	9/2019	Jhun	D14/134
D859,313	S *	9/2019	Jhun	D14/134
D859,314	S *	9/2019	Jhun	D14/134
D860,996	S *	9/2019	Jhun	D14/432
D860,997	S *	9/2019	Jhun	D14/432
D863,224	S *	10/2019	Jhun	D14/134
D863,225	S *	10/2019	Jhun	D14/134
D864,117	S *	10/2019	Byrne	D13/139.4
D887,984	S *	6/2020	Byrne	D13/184
2003/0070592	A1	4/2003	Grasse et al.	
2012/0175452	A1	7/2012	Feldstein et al.	
2013/0068870	A1	3/2013	Feldstein et al.	
2014/0265753	A1	9/2014	Soper et al.	
2014/0346268	A1	11/2014	Feldstein et al.	
2015/0166299	A1	6/2015	Feldstein et al.	
2017/0063009	A1 *	3/2017	Los	H01R 27/02
2019/0148874	A1 *	5/2019	Sorrentino	H01R 13/5213 439/136
2019/0161314	A1	5/2019	Replogle et al.	
2019/0166707	A1	5/2019	Pedoeem et al.	

OTHER PUBLICATIONS

“PUFP-CT-SS-WC”, first accessed Jul. 11, 2022. LewElectric.com [https://www.lewelectric.com/catalog/pufp-ct-ss-wc/#productShare] (Year: 2022).*

“Countertop Box Kits”, first published 2016 by Arlington Industries, Inc. (Year: 2016).*

“FT2-1200-ELEC-PTL”, first available Nov. 5, 2021. Published by Crestron Electronics, p. 1. (Year: 2021).*

“FT2-700-ELEC-PTL”, first available Nov. 4, 2021. Published by Crestron Electronics, p. 1. (Year: 2021).*

“Crestron FT2 Series FlipTops™ Revolutionize the Presentation Experience at ISE 2019”, first posted Feb. 4, 2019. Crestron.com [https://www.crestron.com/News/Press-Releases/2019/Crestron-FT2-Series-FlipTops-Revolutionize-the-Pr] (Year: 2019).*

AMX, HydraPort: Connecting the Perfect Meeting, Product Guide, Rev. V3 (Sep. 8, 2014), available at pdf.archiexpo.com/pdf/amx/hydraport/51274-177337.html.

Arthur Holm, Albiral Display Solutions SL, Catalog, EN2016-2017, available at www.arthurholm.com/wp-content/uploads/2017/03/AH_Catalogue_2017.pdf.

Bachmann Electrical Engeneering Ltd., Facility Solutions, System solutions for Office, conference and meeting rooms, Jun. 2016, available at genproel-el.gr/data/documents/2017.pdf.

Crestron, Crestron FlipTops, D4520-C_201410, 2014, available at www.crestron.com/downloads/pdf/product_brochures/crestron_fliptops_brochure.pdf.

Extron, Cable Cubby 202, 2014, available at www.extron.com/download/files/brochure/CC_202_Printable_A4.pdf.

Extron, Cable Cubby 500, 2014, available at www.extron.com/download/files/brochure/CC_500_Printable_A4.pdf.

Extron, Cable Cubby 700, 2014, available at www.extron.com/download/files/brochure/CC_700_Printable_A4.pdf.

Extron, Cable Cubby 1200, 2014, available at www.extron.com/download/files/brochure/CC_1200_Printable_letter_size.pdf.

Extron, Cable Cubby 1400, 2014, available at www.extron.com/download/files/brochure/CC_1400_Printable_letter_size.pdf.

Extron, Cable Cubby Series 2, Mar. 2016, 68-2604-01, Rev. C, available at www.extron.com/download/files/brochure/cable_cubby_series_2_verA4.pdf.

Extron Catalog, AAP—Architectural Adapter Plates, 2012 Product Catalog, available at www.extron.com/download/files/general/aaps_12cat_en.pdf.

FSR Inc., T6 Flex, LIT1434A, 2015, available at fsrinc.com/documents/spec-sheet/9187-lit1434c-t6-flex-spec-sheet-pdf/file.

FSR Inc., Table Boxes, LIT1187H, 2014, available at www.novotech.com.mx/wp-content/uploads/2016/03/1187H-Table-Box-Brochure.pdf.

Herman Miller, Inc., Logic Power Access Solutions, 2015, available at www.hermanmiller.com/content/dam/hermanmiller/documents/product_literature/product_sheets/Logic_Power_Access_Solutions_product_sheet.pdf.

Extron Electronics, “Hideaway” Family Brochure, 2002.

Extron Electronics, Extron® Hideaway Series Brochure, 2002.

Kramer Electronics LTD., K-Able/XL Box Cable Retractor, User Manual, P/N: 2900-300441 Rev 3, 2015, available at k.kramerav.com/downloads/manuals/k-able_xl_box.pdf.

Kindermann, MultiMedia connection systems, 2014, available at www.kindermann.de/fileadmin/medien/printmedien/MultiMedia_connection_systems/GB/MultiMedia_connection_systems_GB.pdf.

Legrand, Wiremold® AVIP Series Device Plates, ED1670R3—Updated Jan. 2015, available at www.legrand.us/wiremold.aspx.

Legrand, Wiremold®, Dequorum™ Flip-Up Table Boxes, ED1755 0715, 2015, available at www.middleatlantic.com.

Legrand, Wiremold® Table Boxes, Table Boxes bring technology to the point-of-use, ED1706R5—Updated Mar. 2016, available at www.legrand.us/wiremold.aspx.

Legrand, wiremold®, InteGreat™ A/V Table Box, ED1699R1 0913, 2013, available at www.legrand.us/wiremold.aspx.

Legrand, wiremold®, Meeting Room Solutions, ED1710, 2013, available at www.legrand.us/wiremold.aspx.

Legrand, wiremold® Table Boxes, ED1652R3—Updated Apr. 2016, available at www.legrand.us/wiremold.aspx.

Soltec, LCD-TFT Solutions, 2015, available at dvs.rs/wp-content/uploads/2017/07/ENGLISH-SOLTEC-CATALOGUE.pdf.

* cited by examiner

Primary Examiner — Rosemary K Tarcza

Assistant Examiner — Seth David Kumpf

(74) Attorney, Agent, or Firm — Crestron Electronics, Inc.

(57)

CLAIM

The ornamental design for a fliptop lid, as shown and described.

DESCRIPTION

FIG. 1 shows a top isometric view of a fliptop lid according to an embodiment, showing the lid mounted in a bezel and in a closed position;

FIG. 2 shows a top plan view thereof;

FIG. 3 shows a bottom isometric view thereof;

FIG. 4 shows a top isometric view thereof, showing the lid in an opened position;

FIG. 5 shows a top isometric view of a pair of fliptop lids according to another embodiment, showing the lids mounted in a bezel, each in a closed position;

FIG. 6 shows a top plan view thereof; and

FIG. 7 shows a bottom isometric view thereof; and,

FIG. 8 shows a top isometric view thereof, showing one lid in an opened position and one lid in a closed position.

The broken lines in the figures are for the purpose of illustrating portions of the fliptop lid that form no part of the claimed design.

1 Claim, 4 Drawing Sheets

Pedoeem, A.
FLIPTOP LID

ATTORNEY DOCKET NO.
CP00535-02

1/4

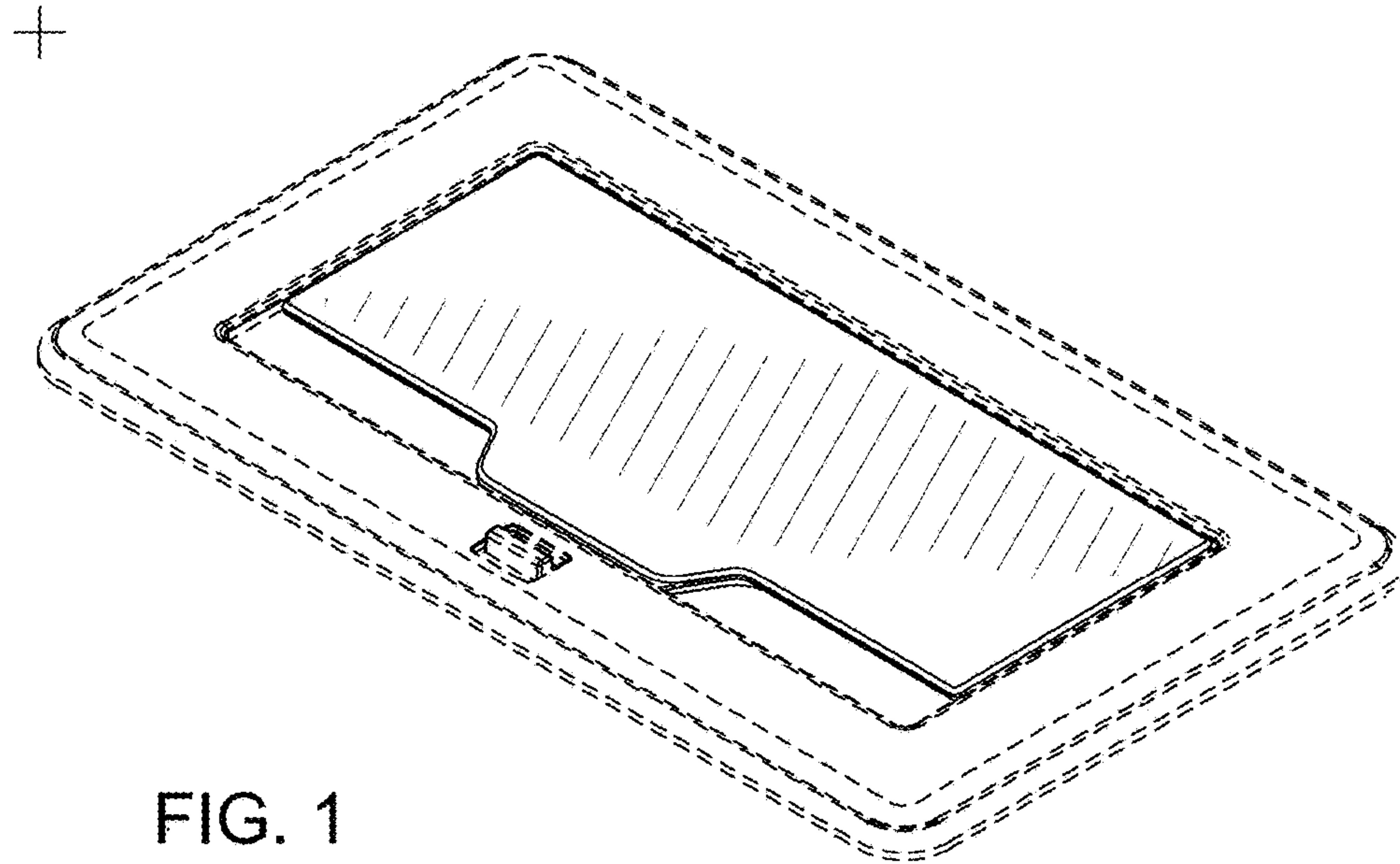

FIG. 1

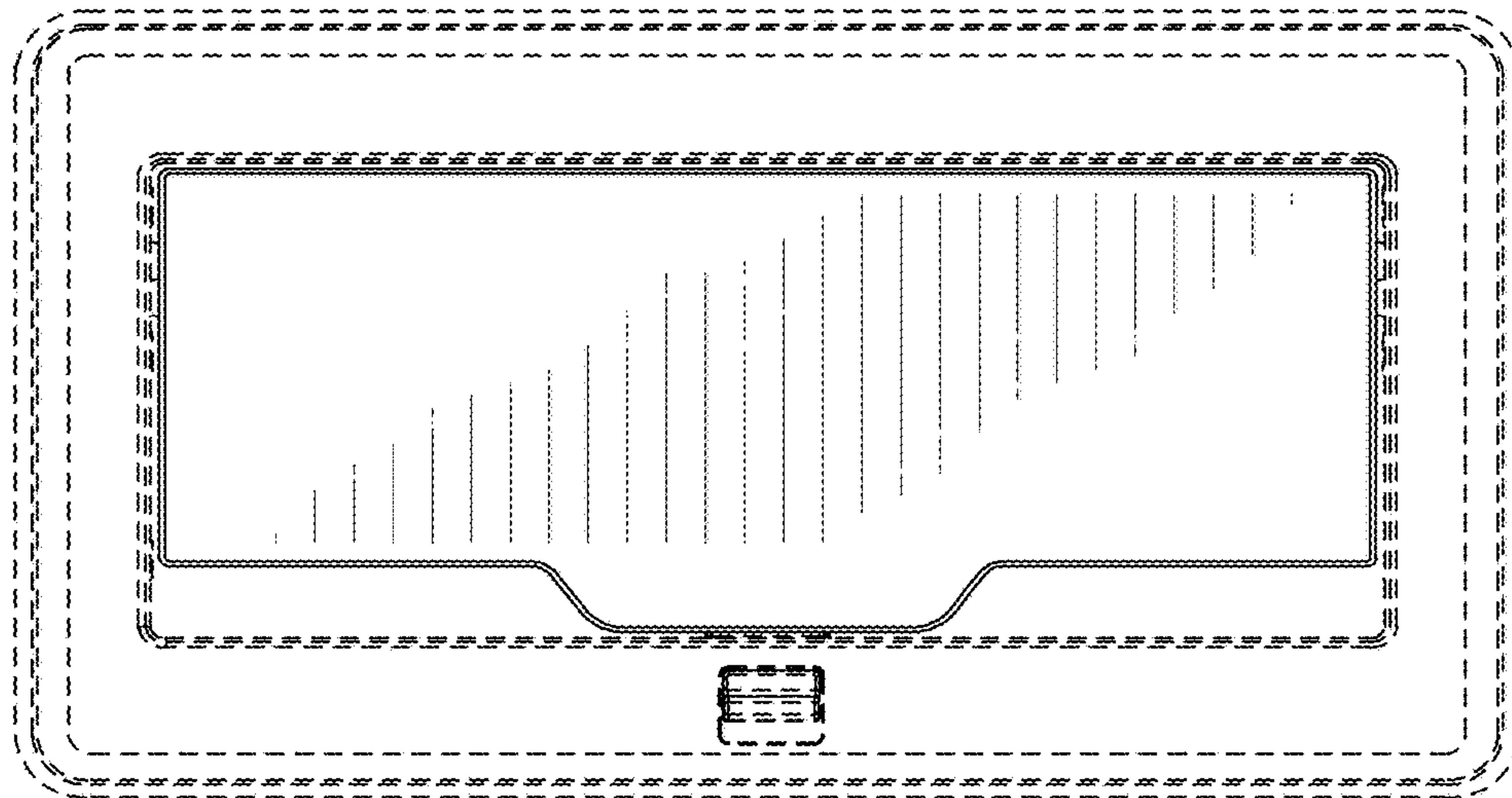

FIG. 2

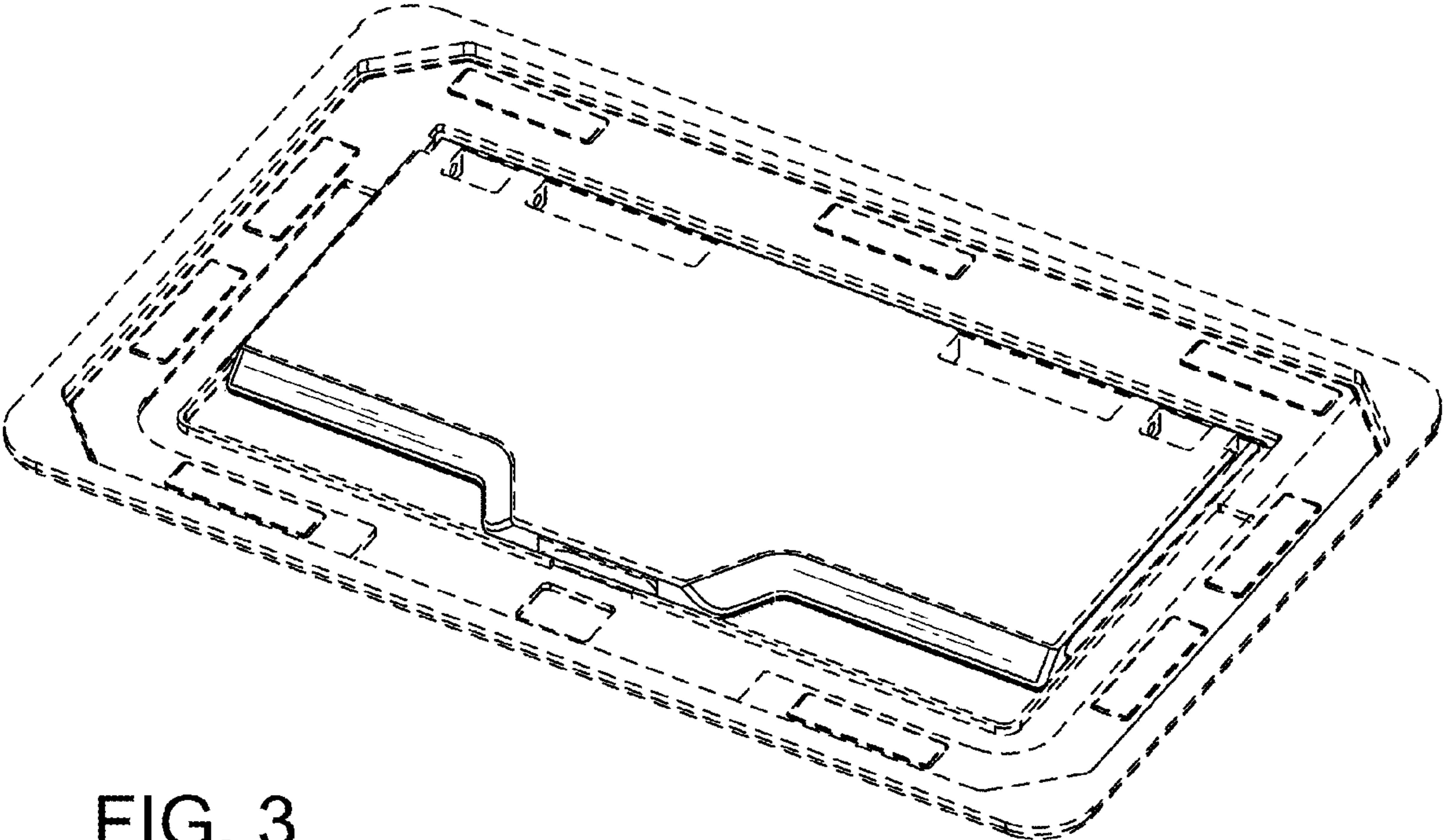

FIG. 3

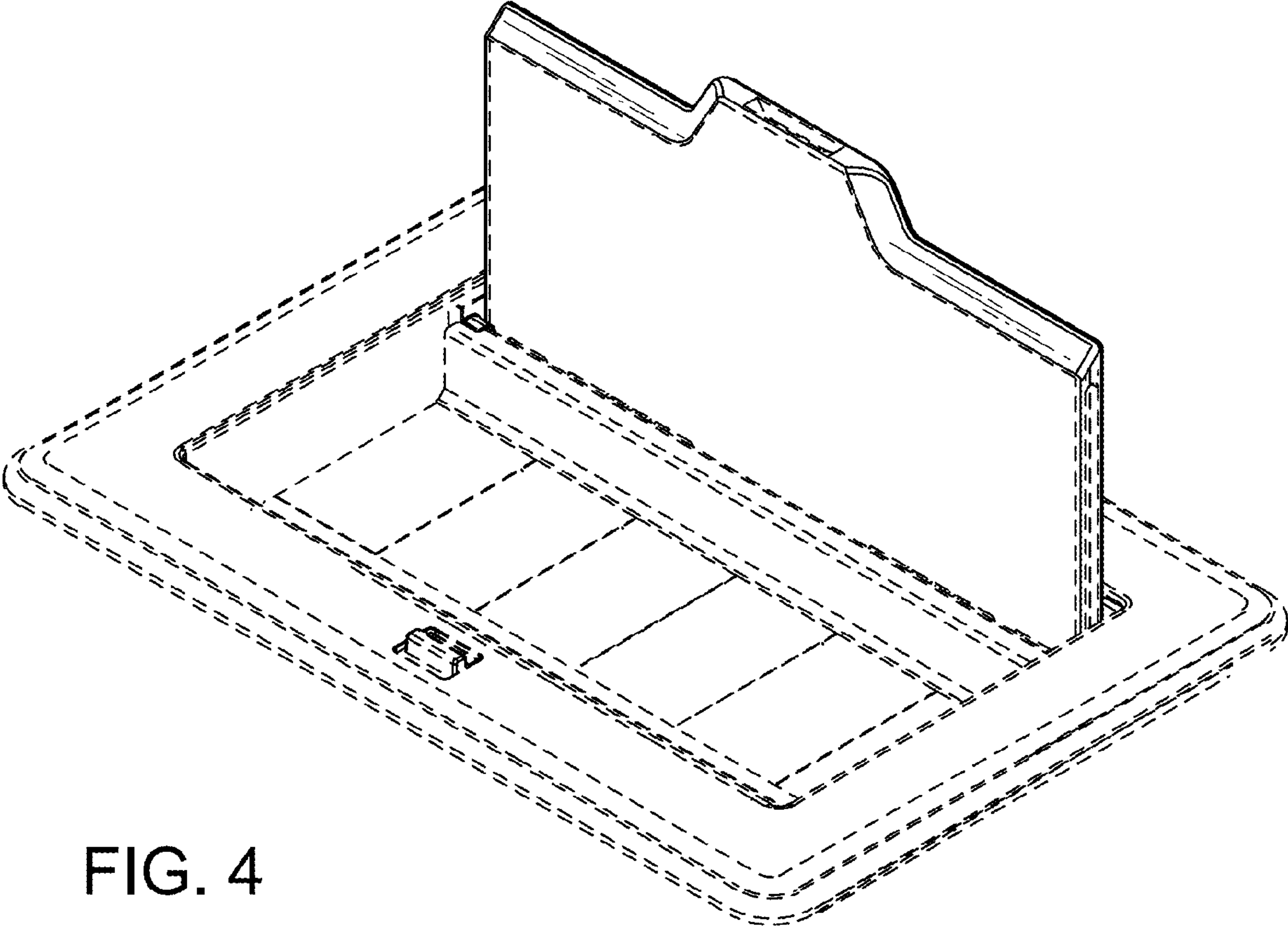

FIG. 4

Pedoeem, A.
FLIPTOP LID

ATTORNEY DOCKET NO.
CP00535-02

3/4

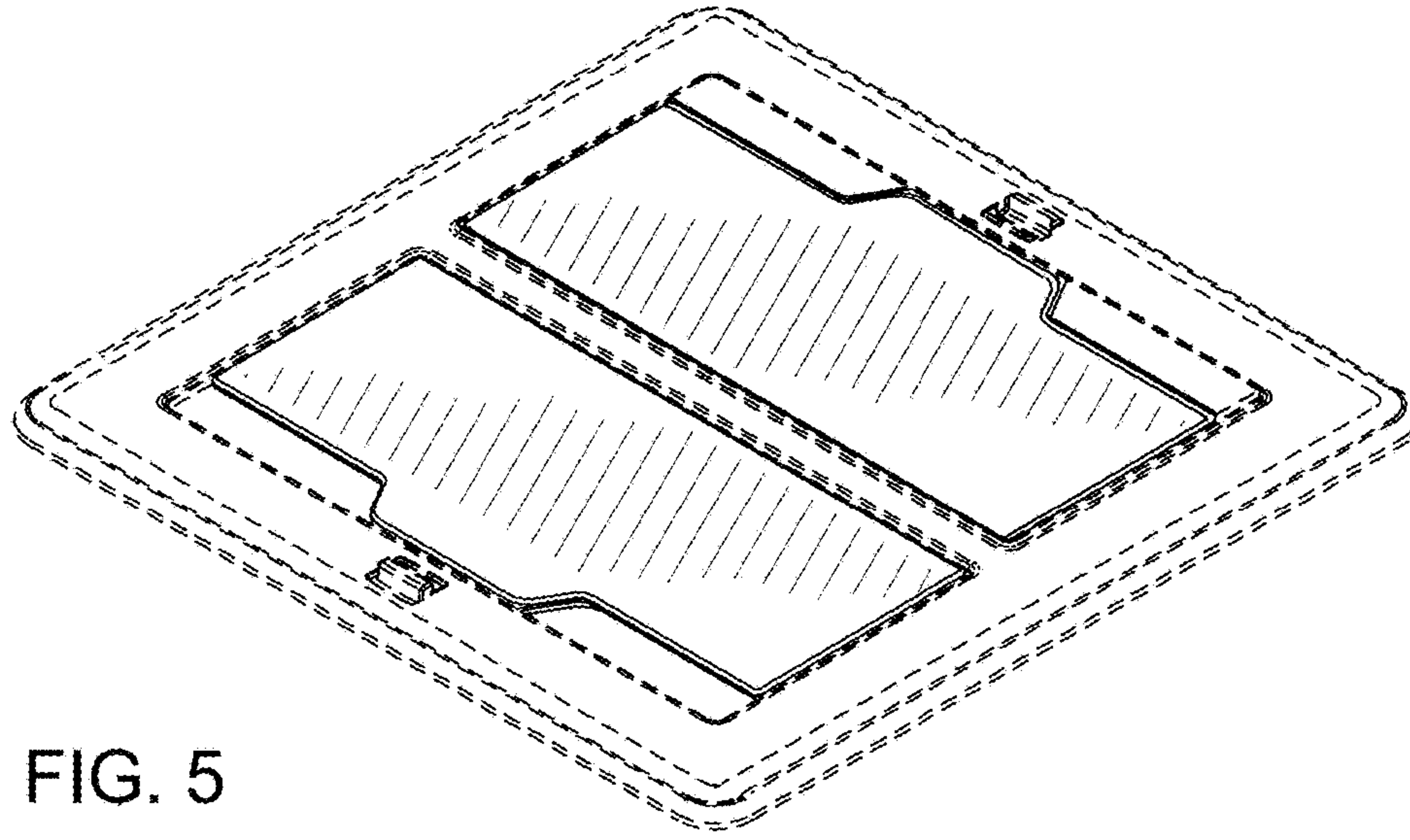

FIG. 5

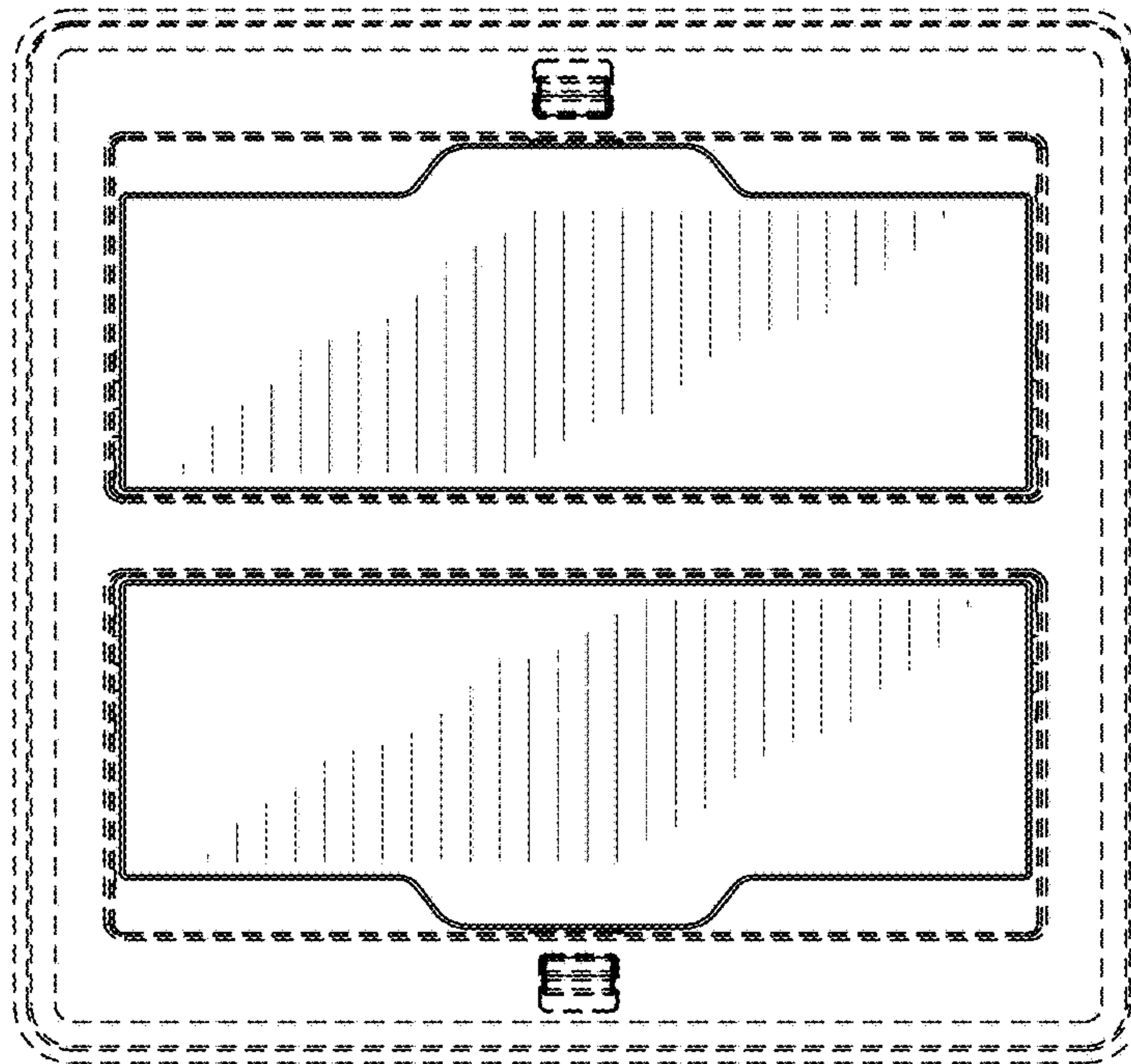

FIG. 6



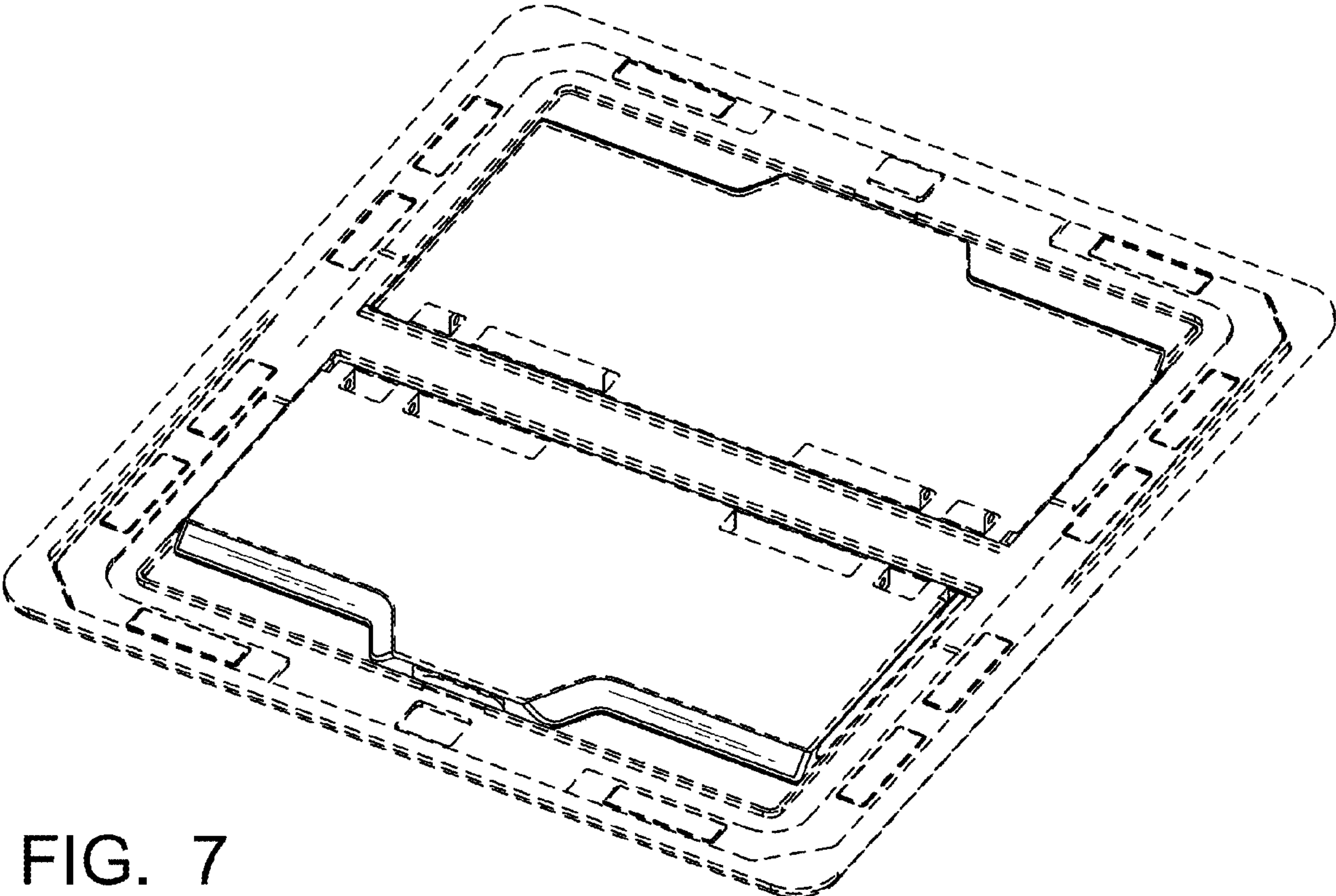

FIG. 7

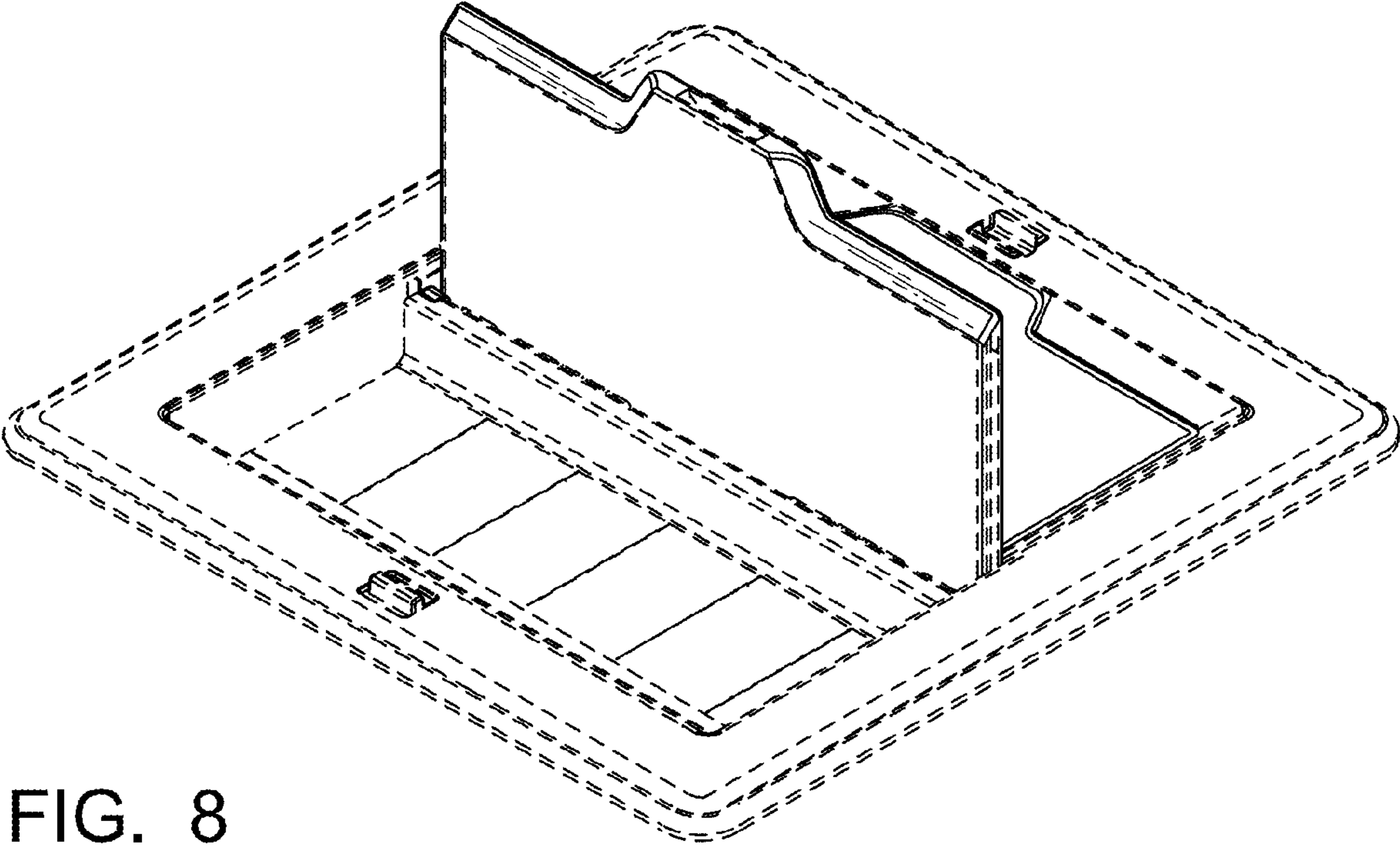

FIG. 8