



US00D965500S

(12) **United States Design Patent** (10) **Patent No.:** **US D965,500 S**  
**Tang** (45) **Date of Patent:** **\*\* Oct. 4, 2022**

(54) **TWO-DIRECTIONAL CHASE RACK FOR A VEHICLE**

(71) Applicant: **Wai Kin Tang**, City of Industry, CA (US)

(72) Inventor: **Wai Kin Tang**, City of Industry, CA (US)

(\*\*) Term: **15 Years**

(21) Appl. No.: **29/754,044**

(22) Filed: **Oct. 6, 2020**

(51) **LOC (13) Cl.** ..... **12-16**

(52) **U.S. Cl.**  
USPC ..... **D12/412**

(58) **Field of Classification Search**  
USPC ..... D12/412, 406, 413, 414, 414.1; D6/552; D3/304-306  
CPC ..... B60R 9/04; B60R 9/048; B60R 9/045  
See application file for complete search history.

(56) **References Cited**

**U.S. PATENT DOCUMENTS**

D495,654 S	9/2004	Elwell et al.	
D499,372 S	12/2004	Andersson	
D553,553 S	10/2007	Taylor	
D578,467 S	10/2008	Ohanyan	
D579,853 S	11/2008	Stark	
D669,017 S	10/2012	Robertson	
D709,818 S	7/2014	Zhang	
D717,230 S	11/2014	Fichter	
D763,170 S	8/2016	Marankie	
D810,654 S	2/2018	Dionisopoulos et al.	
D861,575 S	10/2019	Tang	
D866,447 S	11/2019	Ash	
D883,176 S	* 5/2020	Ajam	D12/222
D892,024 S	* 8/2020	Li	D12/222

(Continued)

*Primary Examiner* — Katrina A Betton

(74) *Attorney, Agent, or Firm* — Kirk A. Buhler; Buhler & Associates Patenting

(57) **CLAIM**

The ornamental design for a two-directional chase rack for a vehicle, as shown and described.

**DESCRIPTION**

FIG. 1 is a top perspective view of a two-directional chase rack for a vehicle in a first position;  
 FIG. 2 is a top perspective view in a second position thereof;  
 FIG. 3 is a top plan view in the first position thereof;  
 FIG. 4 is a top plan view in the second position thereof;  
 FIG. 5 is a rear elevation view in the second position thereof;  
 FIG. 6 is a front elevation view in the first position thereof;  
 FIG. 7 is a right-side elevation in the first position view, the left side elevation view being a mirror image thereof;  
 FIG. 8 is a right-side elevation in the second position view, the left side elevation view being a mirror image thereof;  
 FIG. 9 is a left sectional view in the second position taken along lines 9-9 from FIG. 6 thereof;  
 FIG. 10 is a bottom view in the first position thereof;  
 FIG. 11 is a bottom view in the second position thereof;  
 FIG. 12 is a bottom perspective view in the first position thereof;  
 FIG. 13 is a bottom perspective view in the second position thereof;  
 FIG. 14 is a top perspective view in a first position in an environment of use thereof; and,  
 FIG. 15 is a top perspective view in a second position in an environment of use thereof.  
 The broken lines in FIG. 1, FIG. 3, FIG. 6, FIG. 7, FIG. 9, FIG. 10, FIG. 12, FIG. 14 and FIG. 15 depict environmental subject matter and form no part of the claimed design.

**1 Claim, 11 Drawing Sheets**

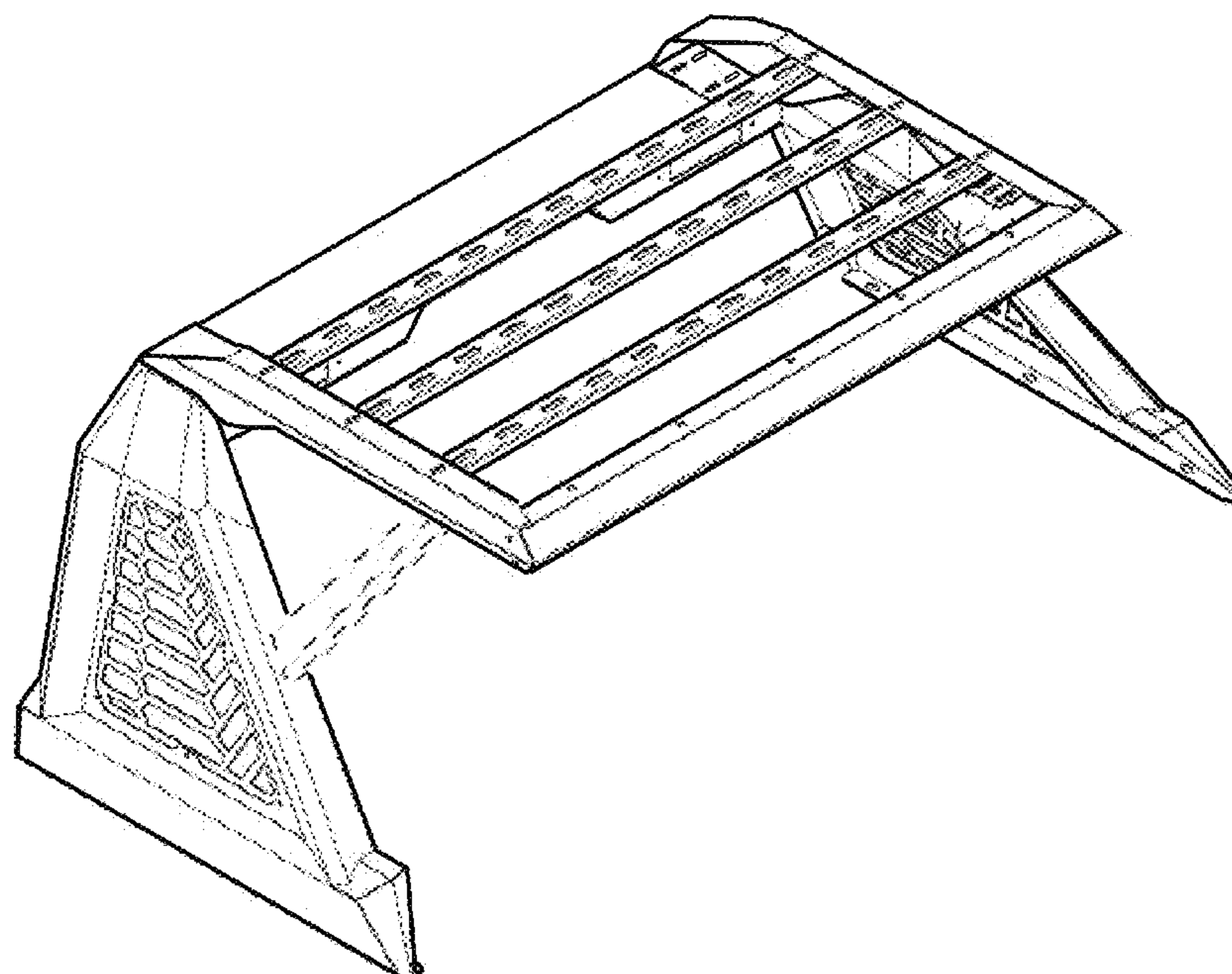

(56)

**References Cited**

U.S. PATENT DOCUMENTS

D920,883 S	*	6/2021	Yung .....	D12/222
D933,576 S	*	10/2021	Ajam .....	D12/222
D947,747 S	*	4/2022	Yung .....	D12/222

\* cited by examiner

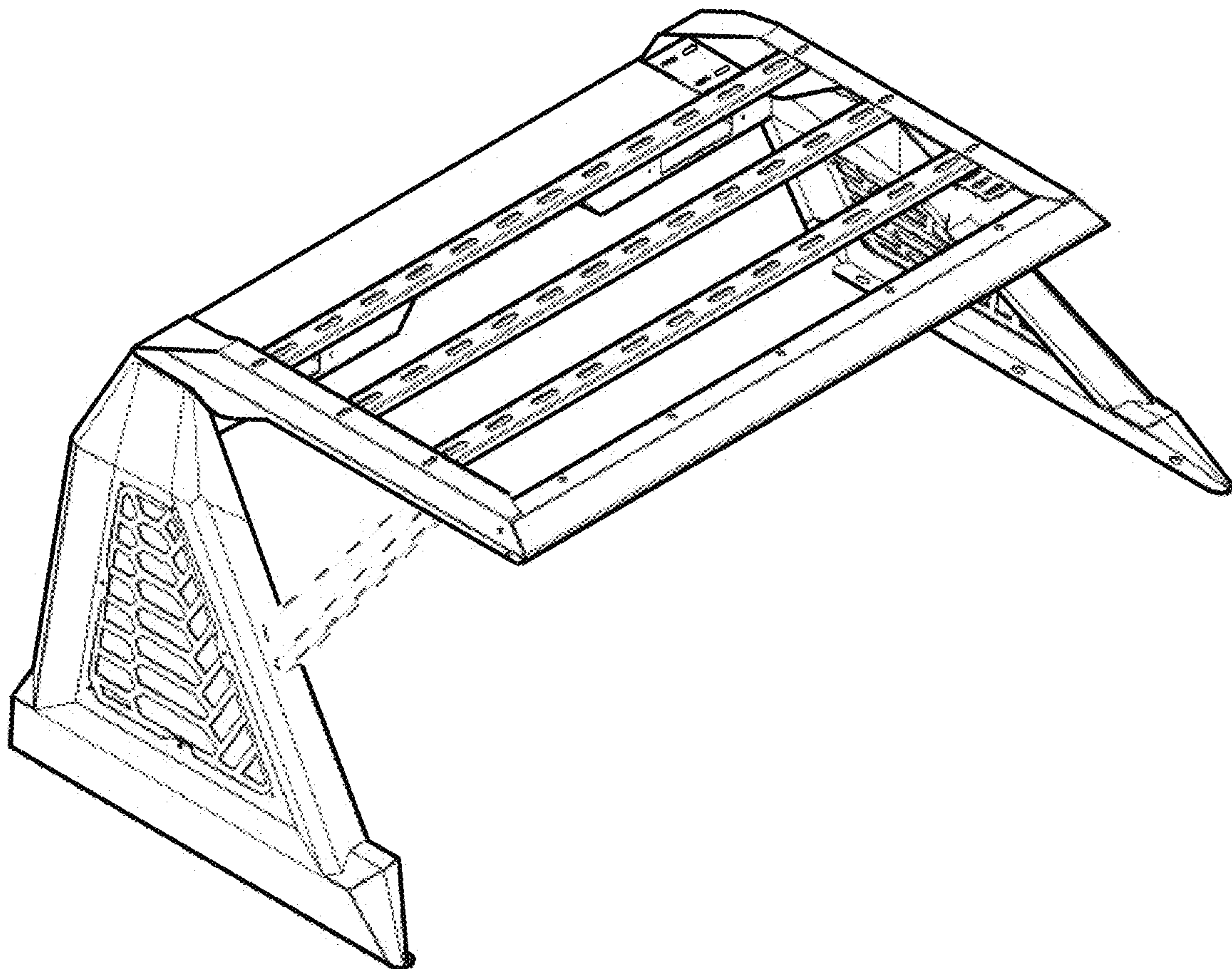

**FIG. 1**



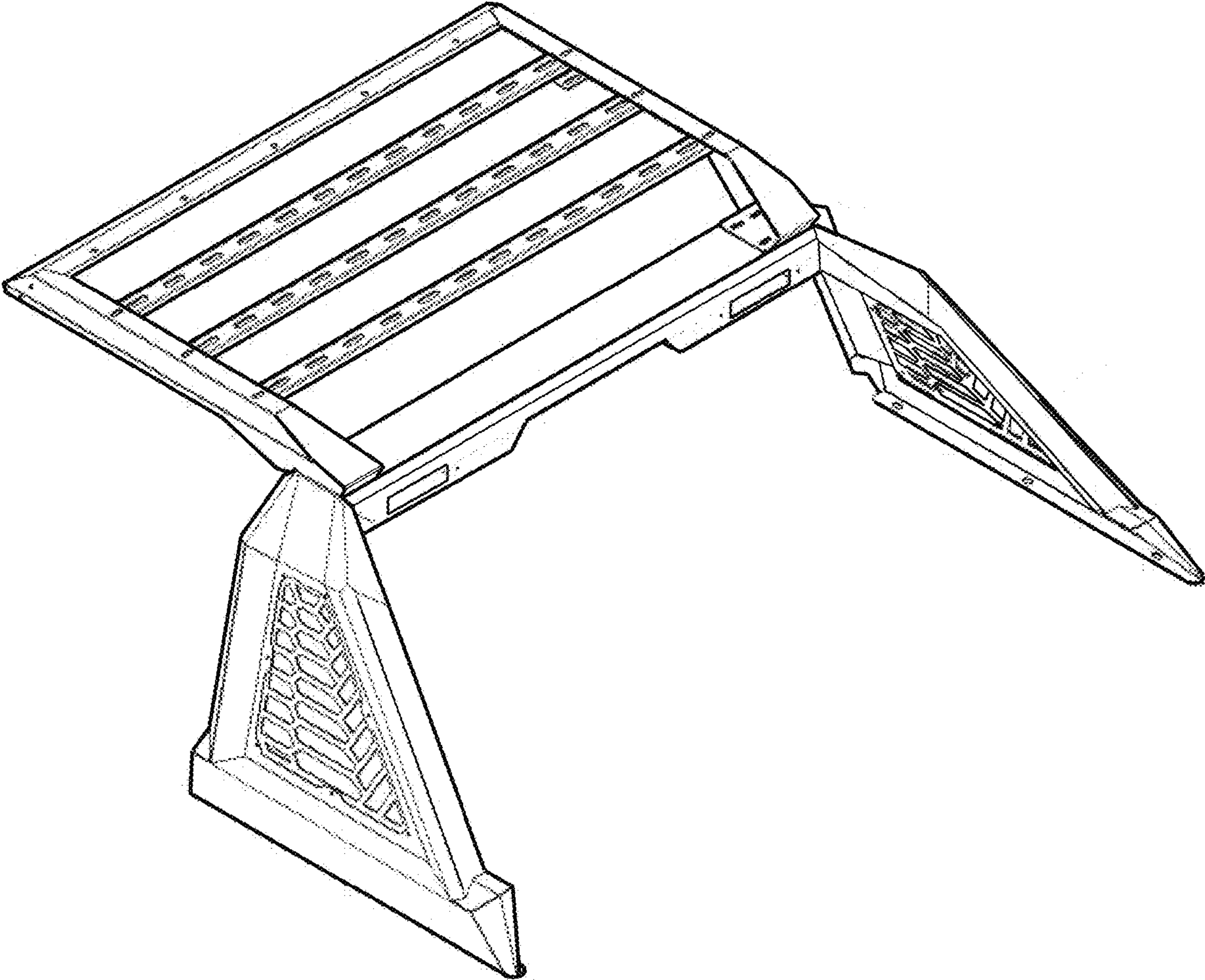

FIG. 2

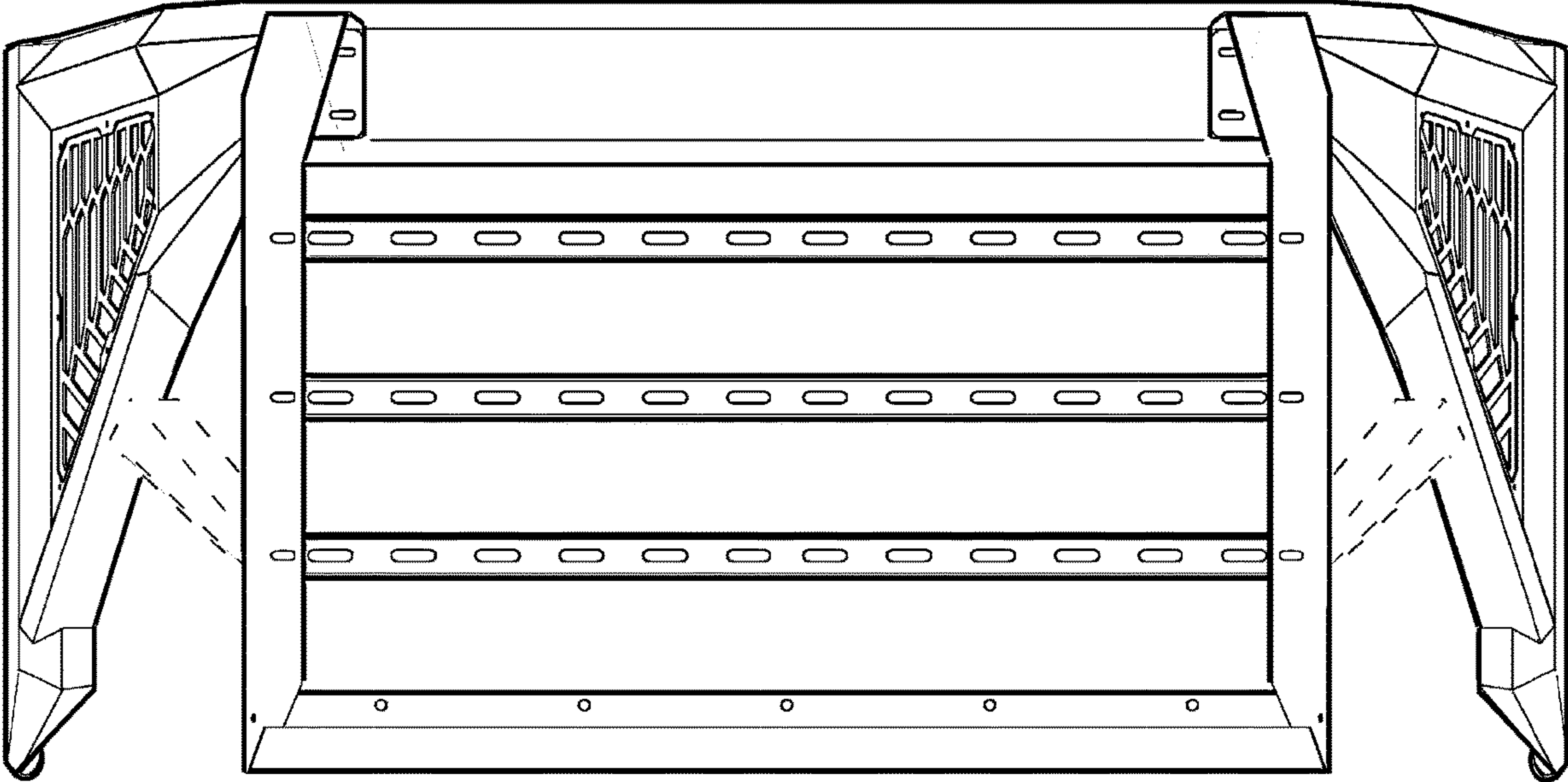

FIG. 3

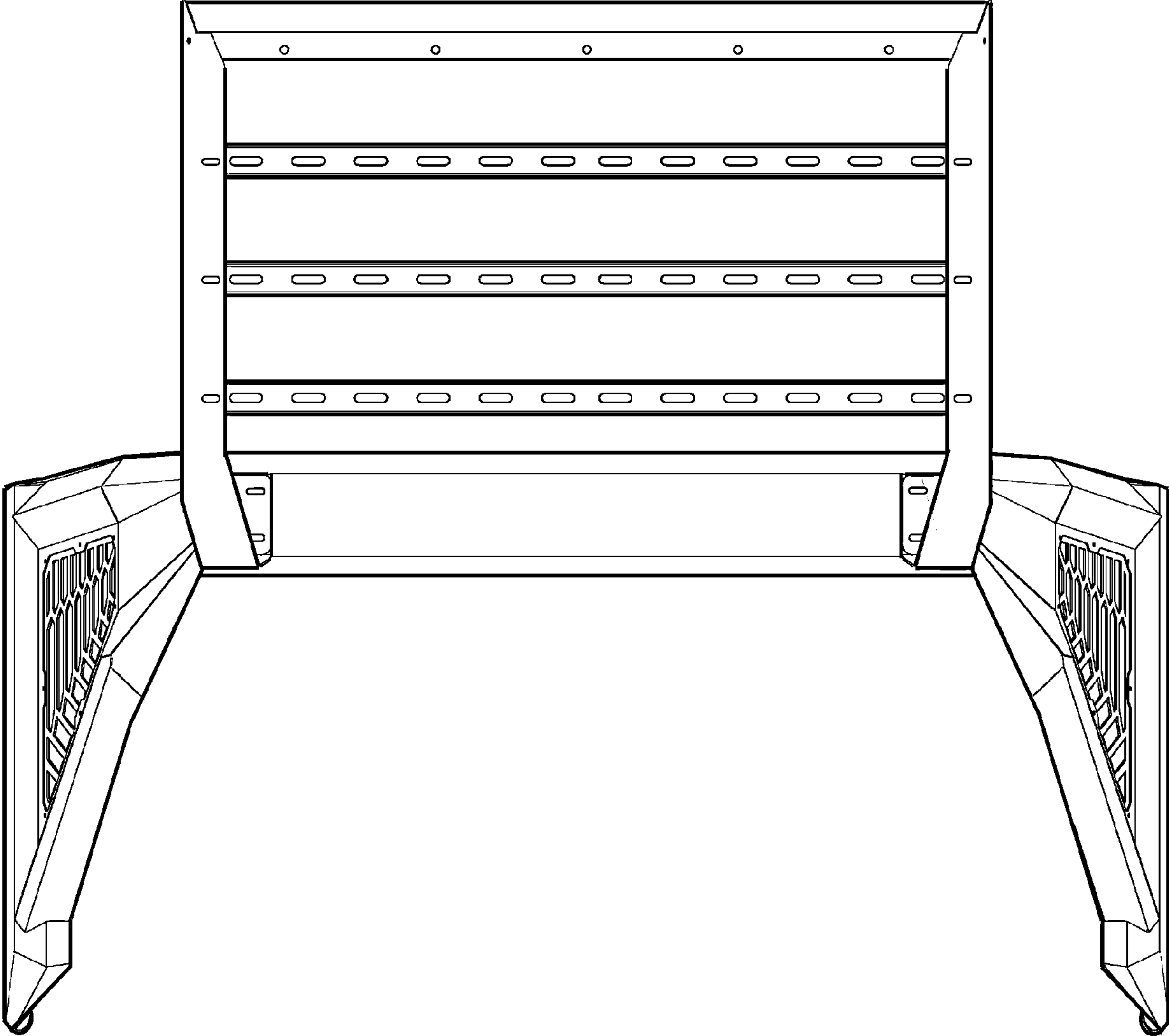
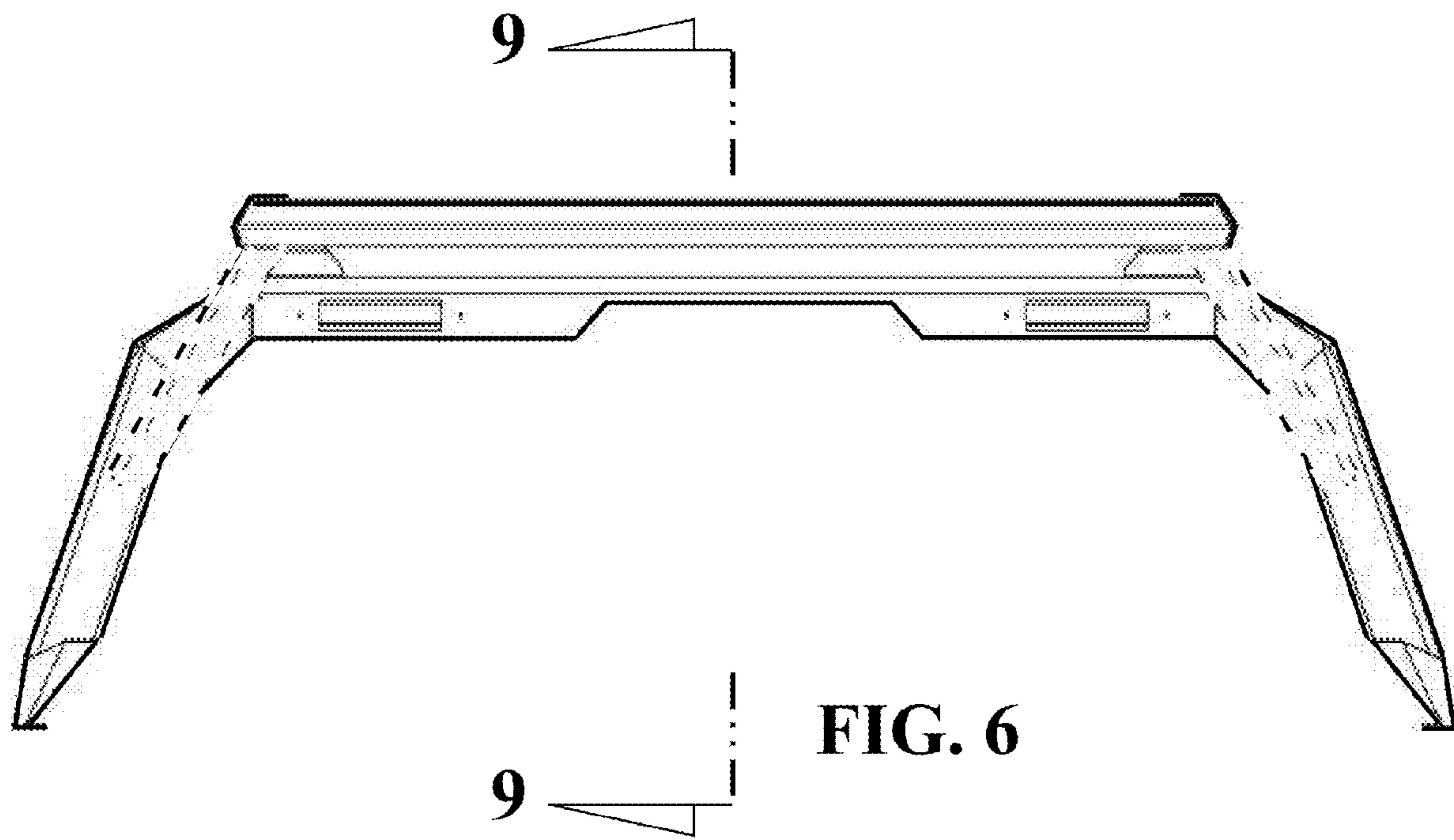
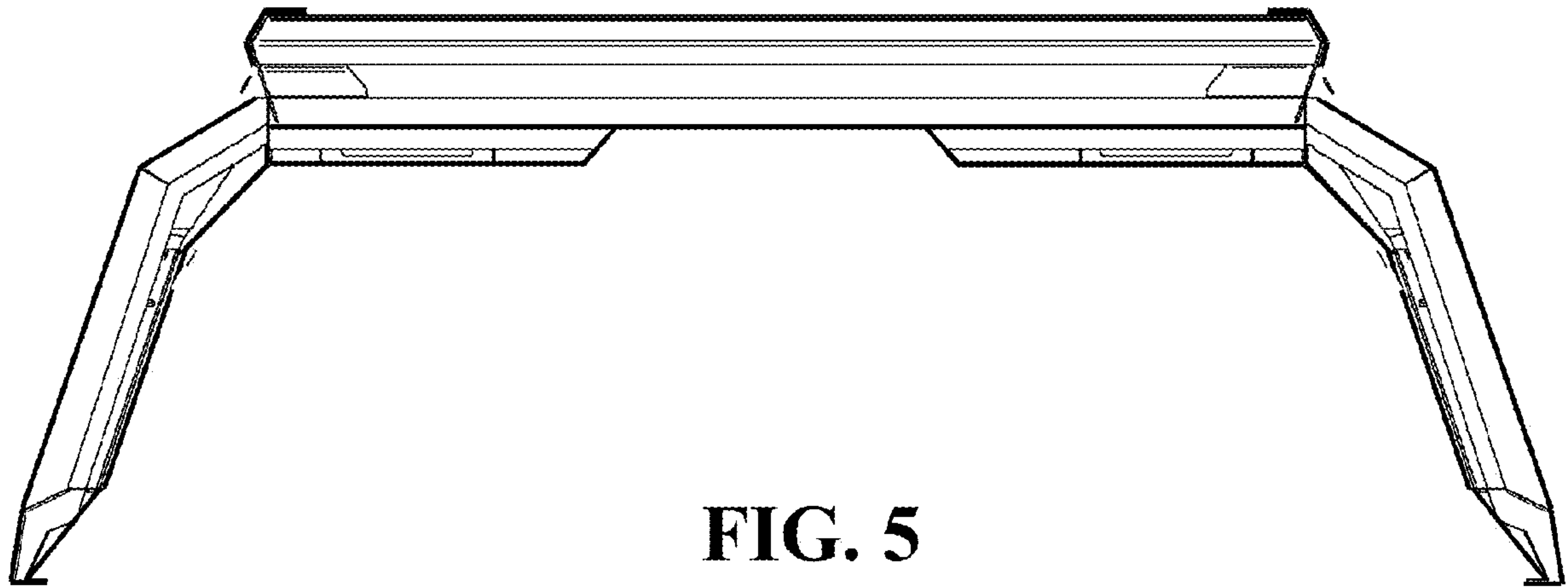
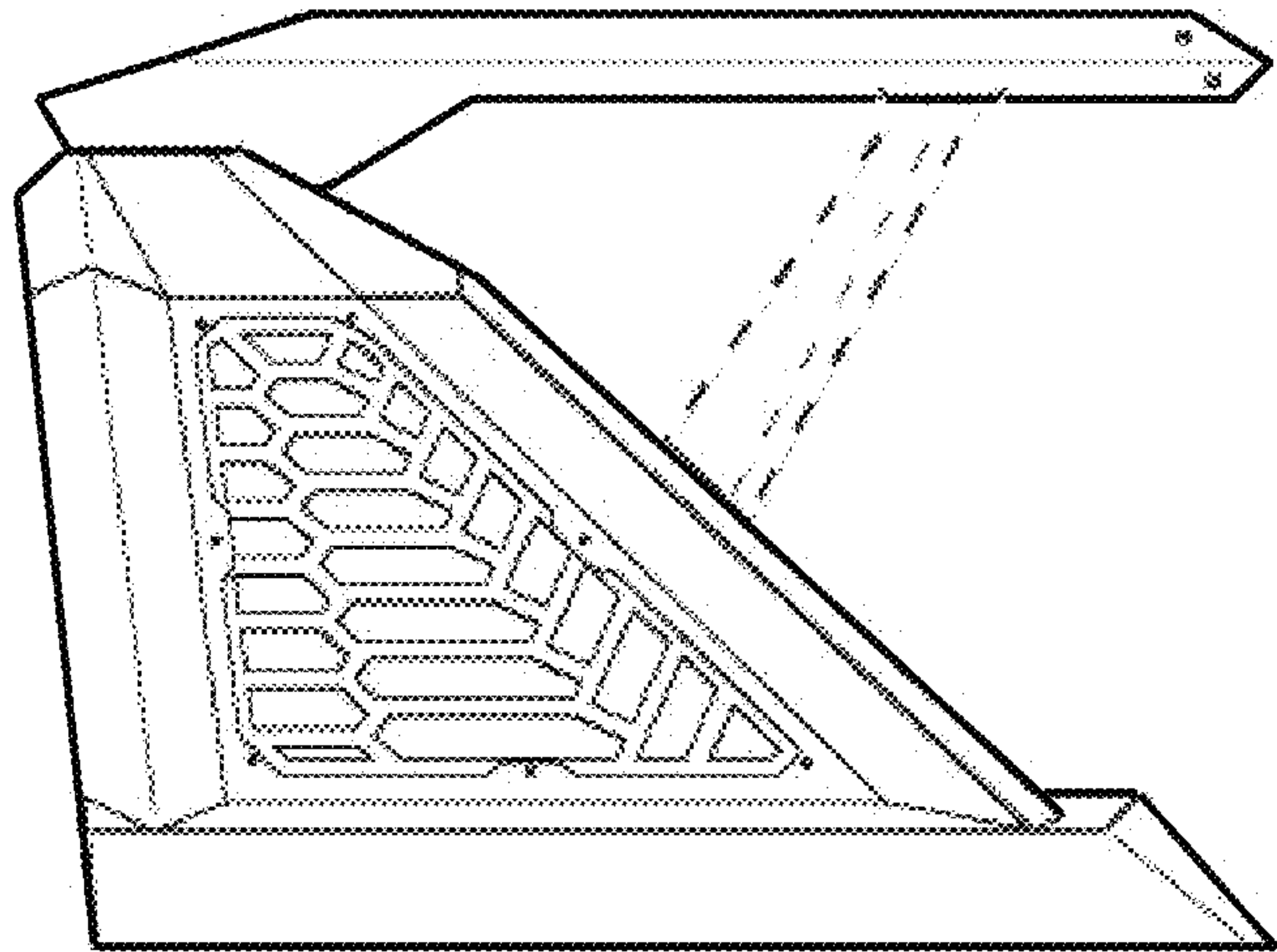
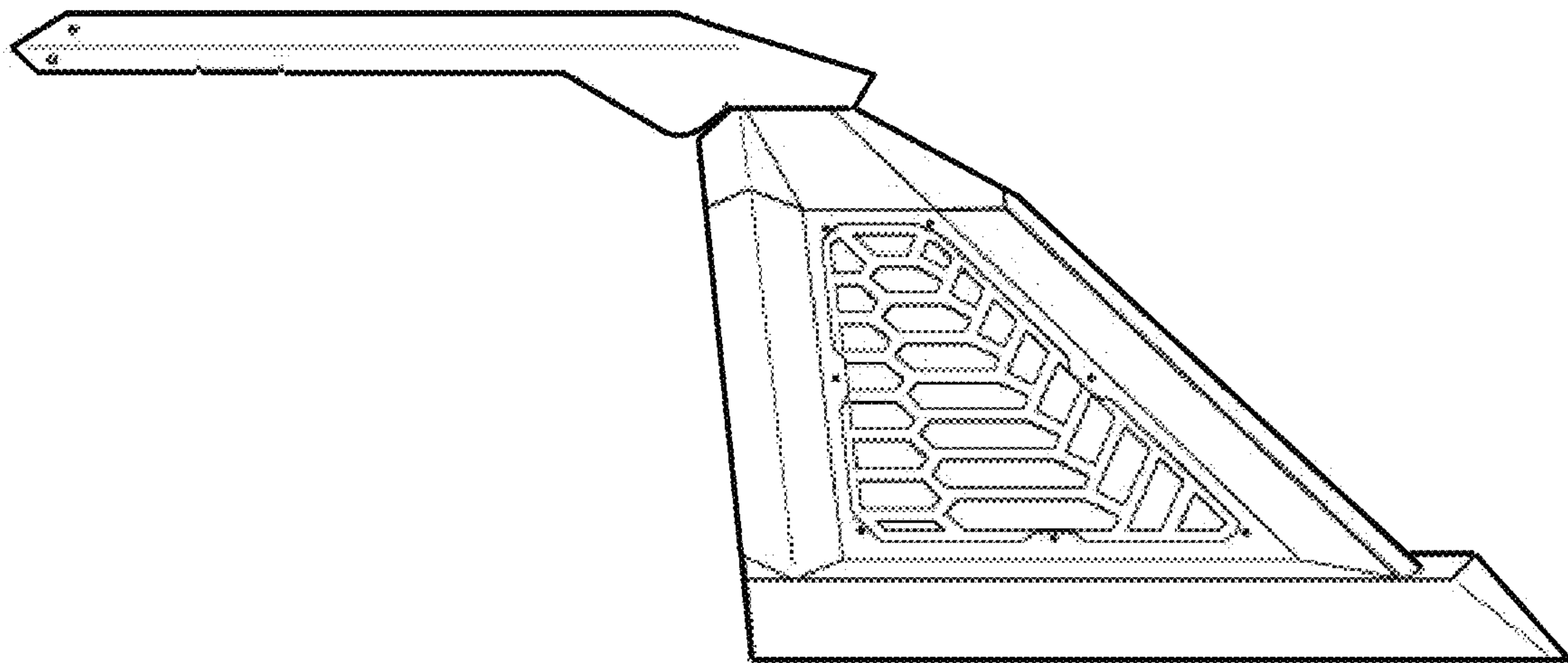

FIG. 4





**FIG. 7**



**FIG. 8**



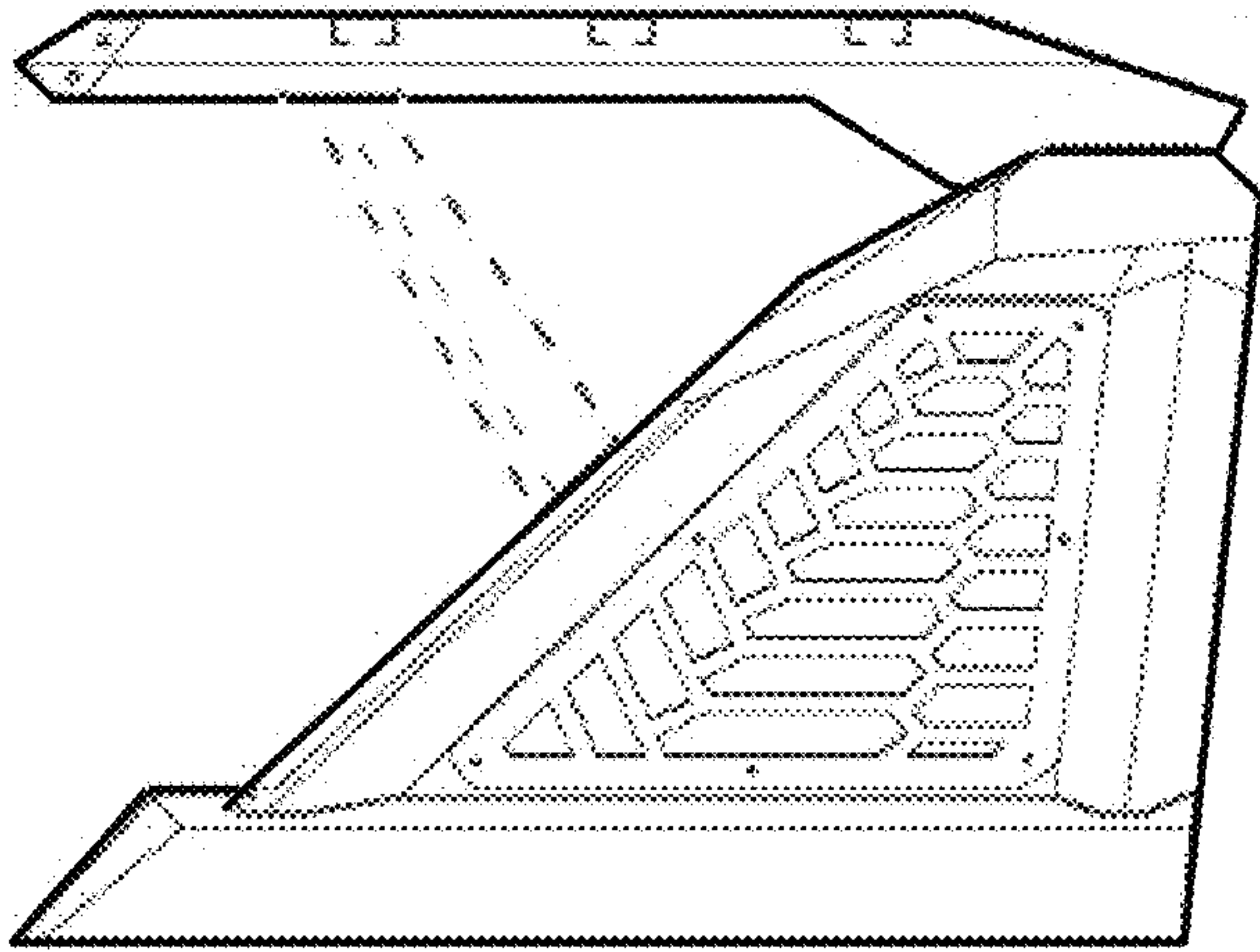

FIG. 9

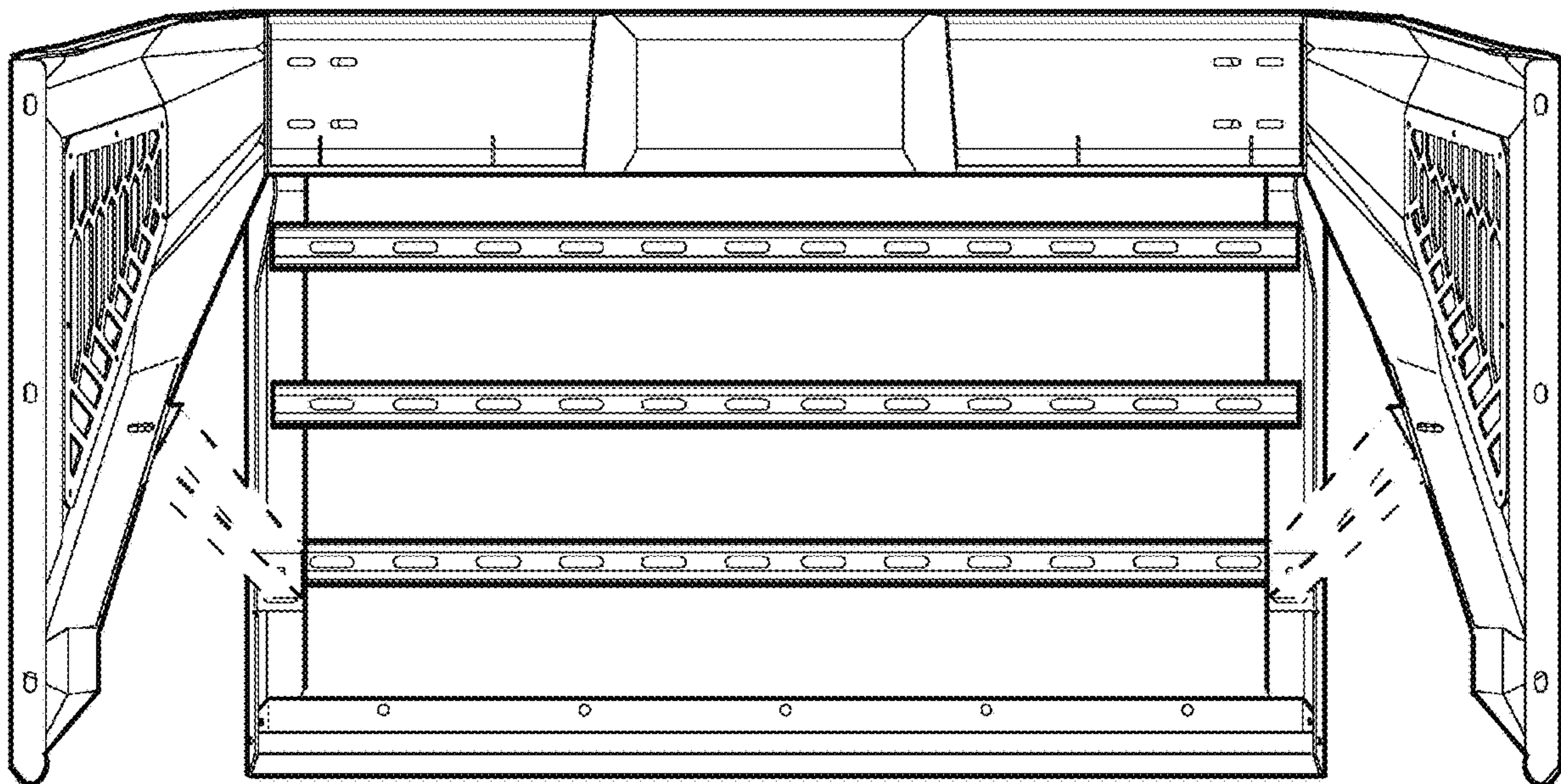

FIG. 10

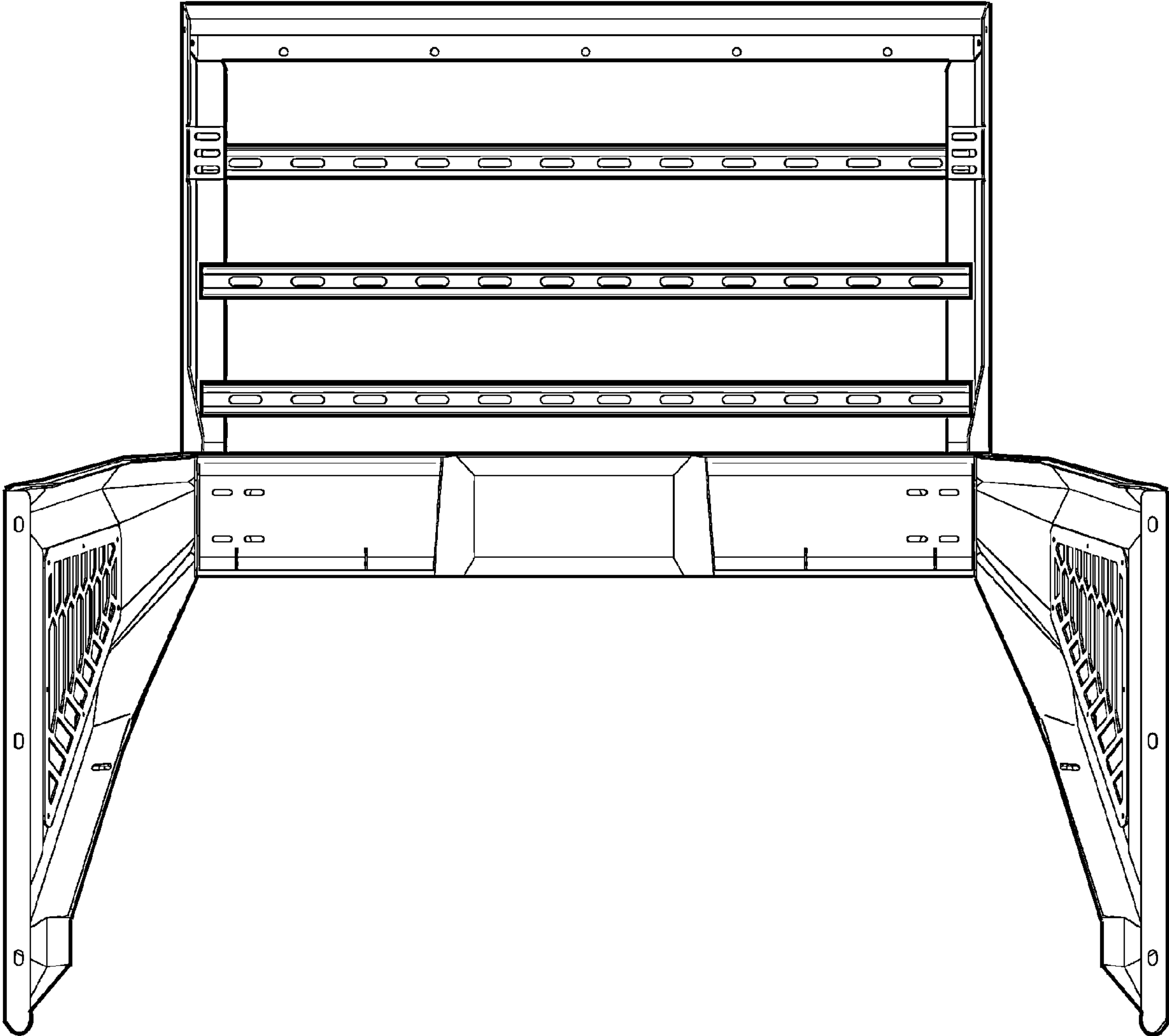
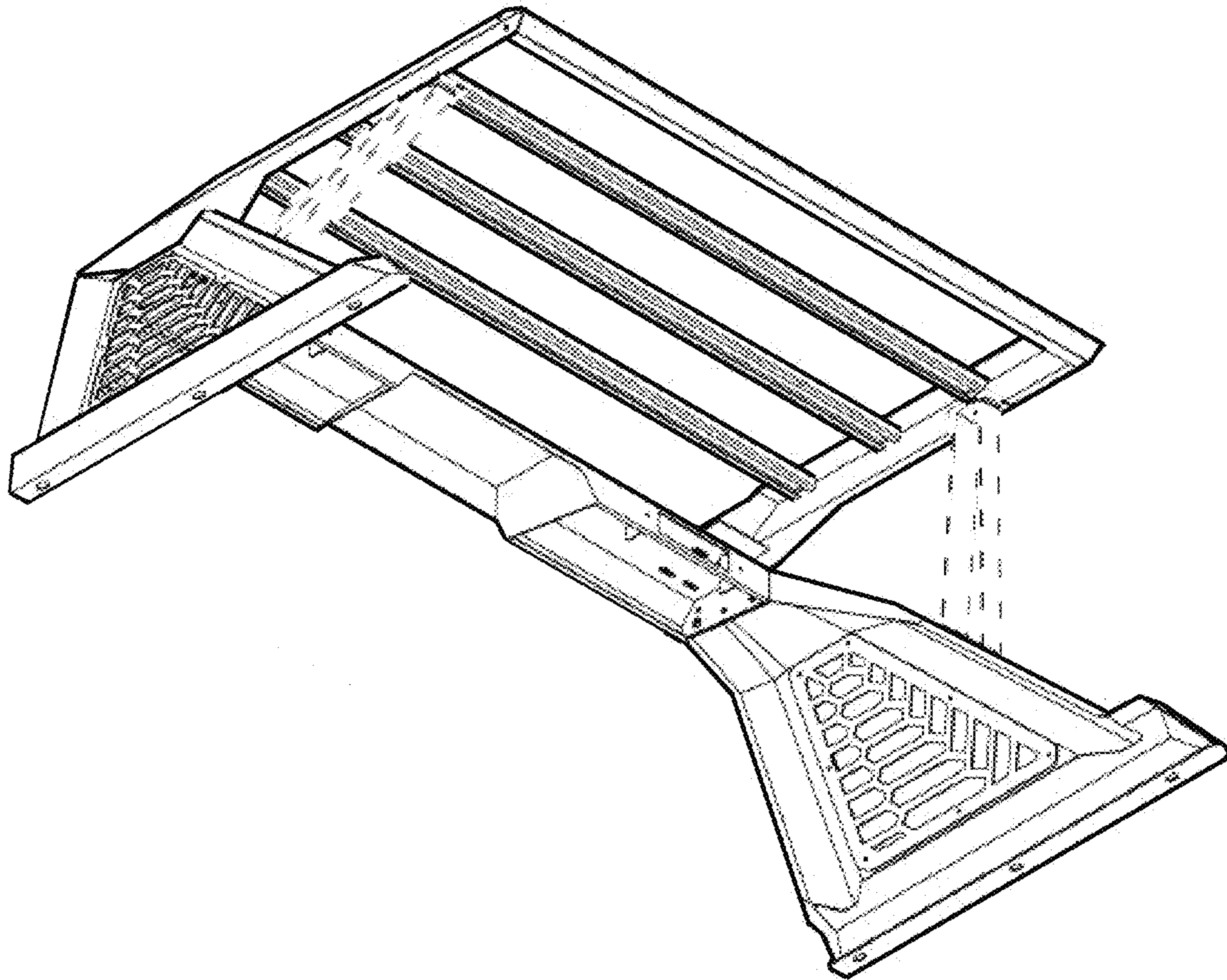

FIG. 11



**FIG. 12**

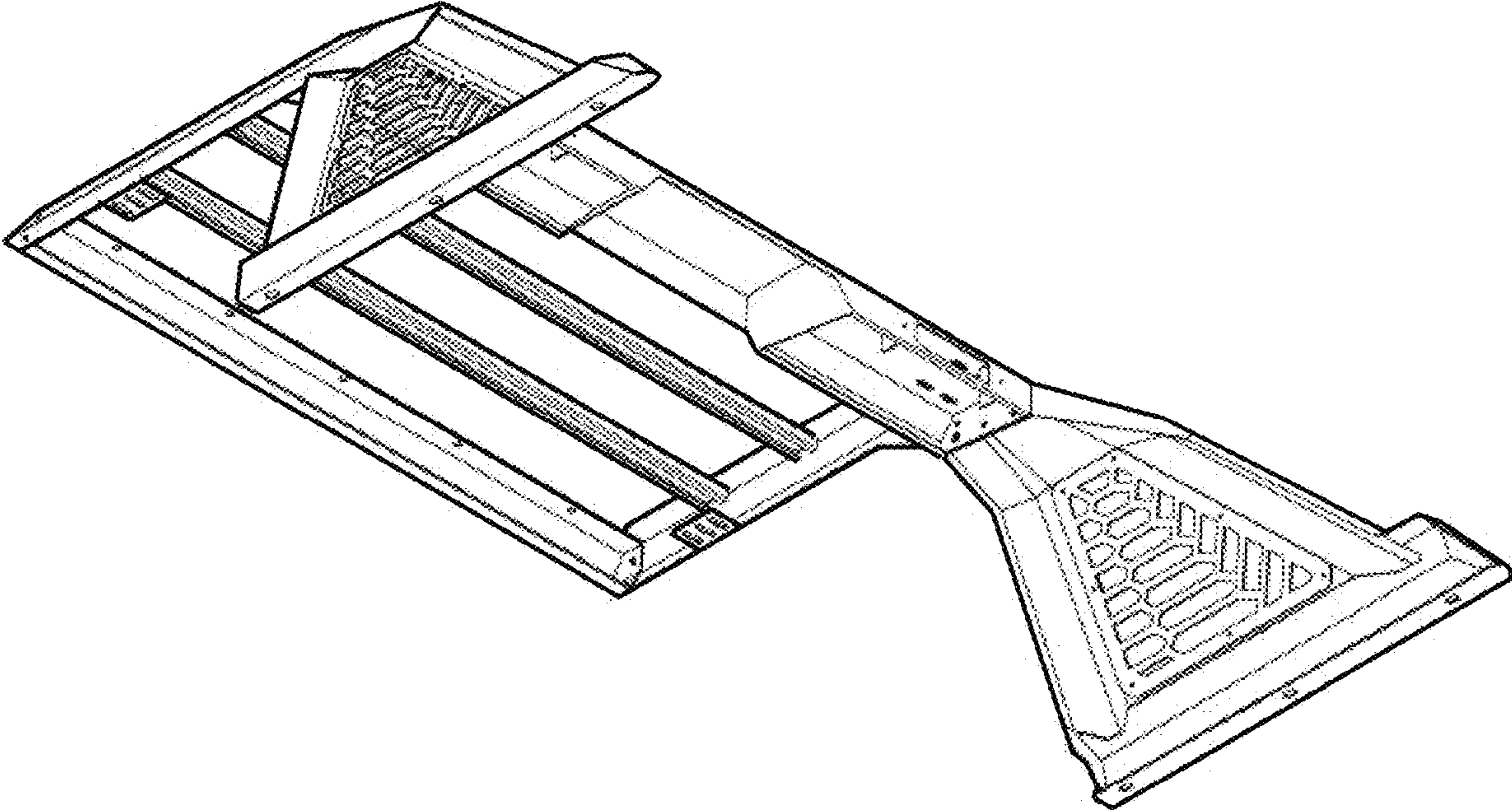
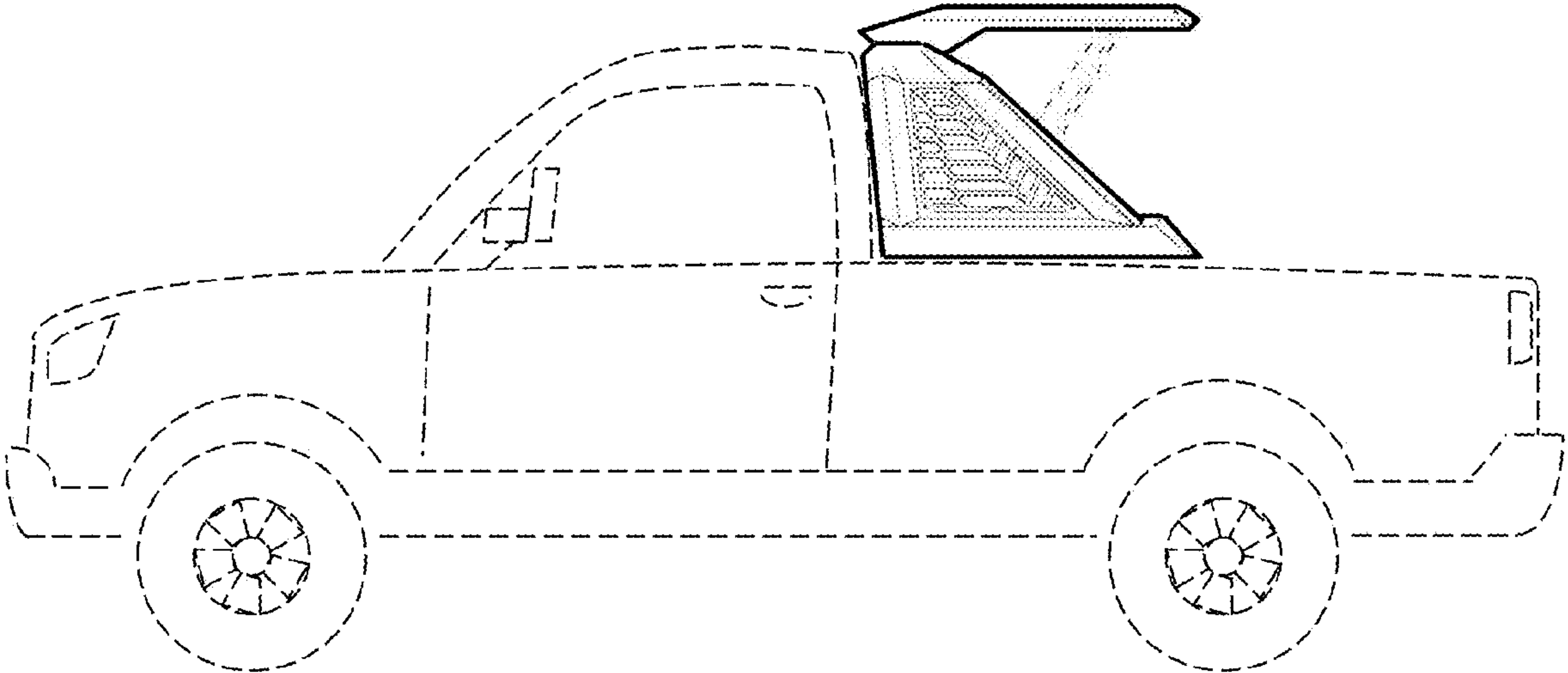
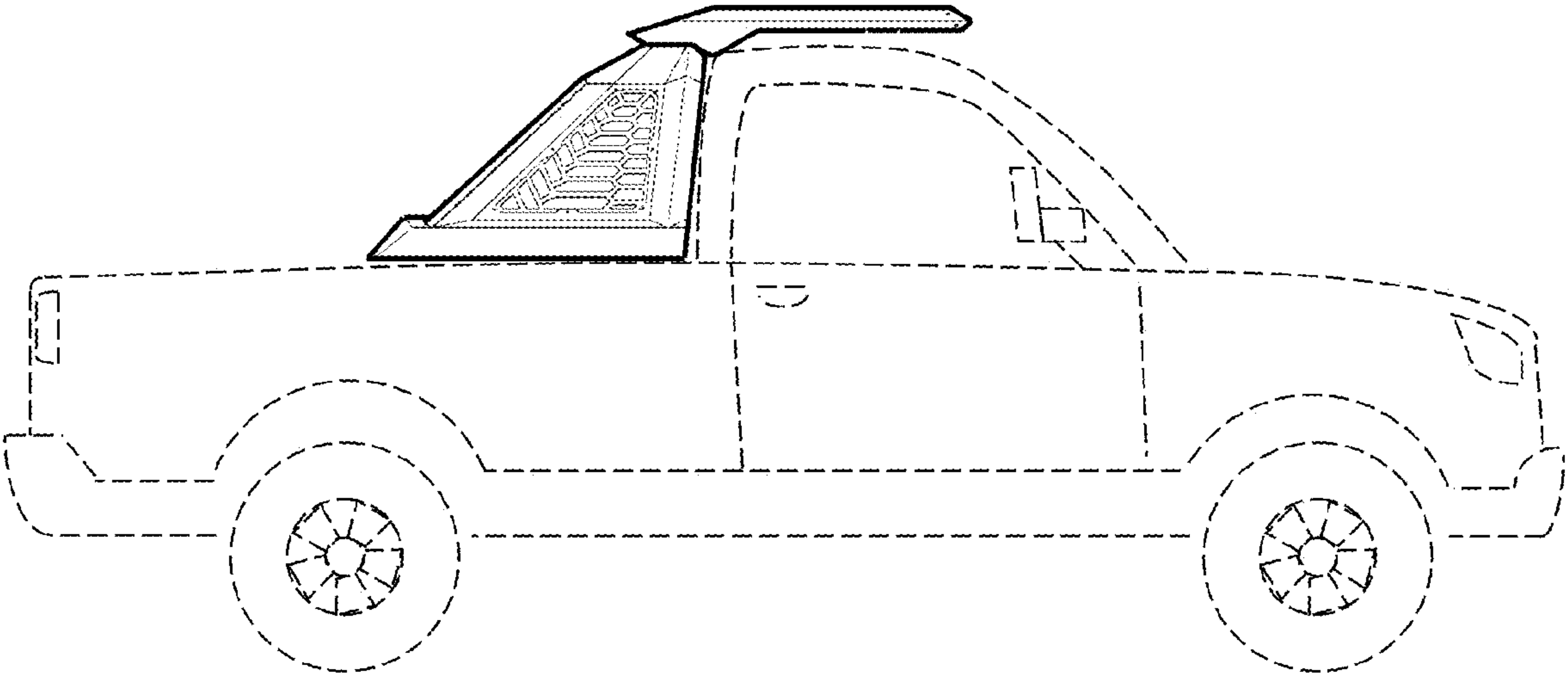

FIG. 13





**FIG. 14**



**FIG. 15**