

US00D965469S

(12) **United States Design Patent** (10) **Patent No.:** **US D965,469 S**
Nell (45) **Date of Patent:** **** Oct. 4, 2022**

(54) **FRONT COWL FOR A VEHICLE**
(71) Applicant: **Federico Nell**, Cypress, TX (US)
(72) Inventor: **Federico Nell**, Cypress, TX (US)
(73) Assignee: **296 Holding LLC**, Houston, TX (US)
(**) Term: **15 Years**

(21) Appl. No.: **29/792,116**

(22) Filed: **Mar. 4, 2022**

(51) **LOC (13) Cl.** **12-02**

(52) **U.S. Cl.**
USPC **D12/16**

(58) **Field of Classification Search**
USPC D12/1, 16, 14, 86, 87, 88, 90, 91, 92
CPC B62D 25/081; B62D 23/00; B62D 21/18;
B62D 21/183; B62D 24/02; B62D 25/00;
B62D 39/00; B62D 49/06; B62D 49/0621
See application file for complete search history.

D859,210 S 9/2019 Lyons et al.
D886,672 S 6/2020 Whitfield et al.
D953,219 S * 5/2022 Bryan-Dunaway D12/173

OTHER PUBLICATIONS

<https://bradsgolfcars.com/golf-car-bodies/> retrieved on Jun. 16, 2022 (Year: 2022).*
https://golfcartscypress.com/custom_golf_carts/2019-custom-club-car-tempo-matte-grigio-gray-agm-maintenance-free-batteries/ retrieved on Jun. 16, 2022 (Year: 2022).*
Bradshaw Club Car Brochure May 2022 (Year: 2022).*

* cited by examiner

Primary Examiner — Ania Aman
(74) *Attorney, Agent, or Firm* — Dunlap Bennett & Ludwig, PLLC

(57) **CLAIM**

I claim, the ornamental design for a front cowl for a vehicle, as shown and described.

(56) **References Cited**

U.S. PATENT DOCUMENTS

D271,008 S	10/1983	Saporito	
D292,899 S	11/1987	Samuelson et al.	
D345,717 S	4/1994	Molzon et al.	
D503,657 S *	4/2005	Katoh	D12/14
D503,905 S *	4/2005	Saito	D12/1
D571,689 S	6/2008	Andrews et al.	
D586,694 S *	2/2009	Huang	D12/14
D617,235 S	6/2010	Dai	
D617,681 S *	6/2010	Tuo	D12/16
D636,295 S *	4/2011	Eck	D12/1
D665,305 S *	8/2012	Eck	B60K 5/00 D12/14
D721,012 S	1/2015	Zhang	
D764,349 S *	8/2016	Kuramoto	D12/14
D780,627 S *	3/2017	Jhant	D12/14
D809,968 S	2/2018	Lacock et al.	
D810,620 S	2/2018	Lacock et al.	

DESCRIPTION

FIG. 1 is a top front right perspective view of a front cowl for a vehicle, showing my new design; FIG. 2 is a front elevation view thereof; FIG. 3 is a rear elevation view thereof; FIG. 4 is a left side elevation view thereof; FIG. 5 is a right side elevation view thereof; FIG. 6 is a top plan view thereof; FIG. 7 is a bottom plan view thereof; and, FIG. 8 is a right side elevation view thereof, shown in use with a vehicle. The broken lines shown in FIGS. 2-5 and 7 depict portions of the front cowl that form no part of the claimed design. The broken lines shown in FIG. 8 depict environment of a vehicle that forms no part of the claimed design.

1 Claim, 5 Drawing Sheets

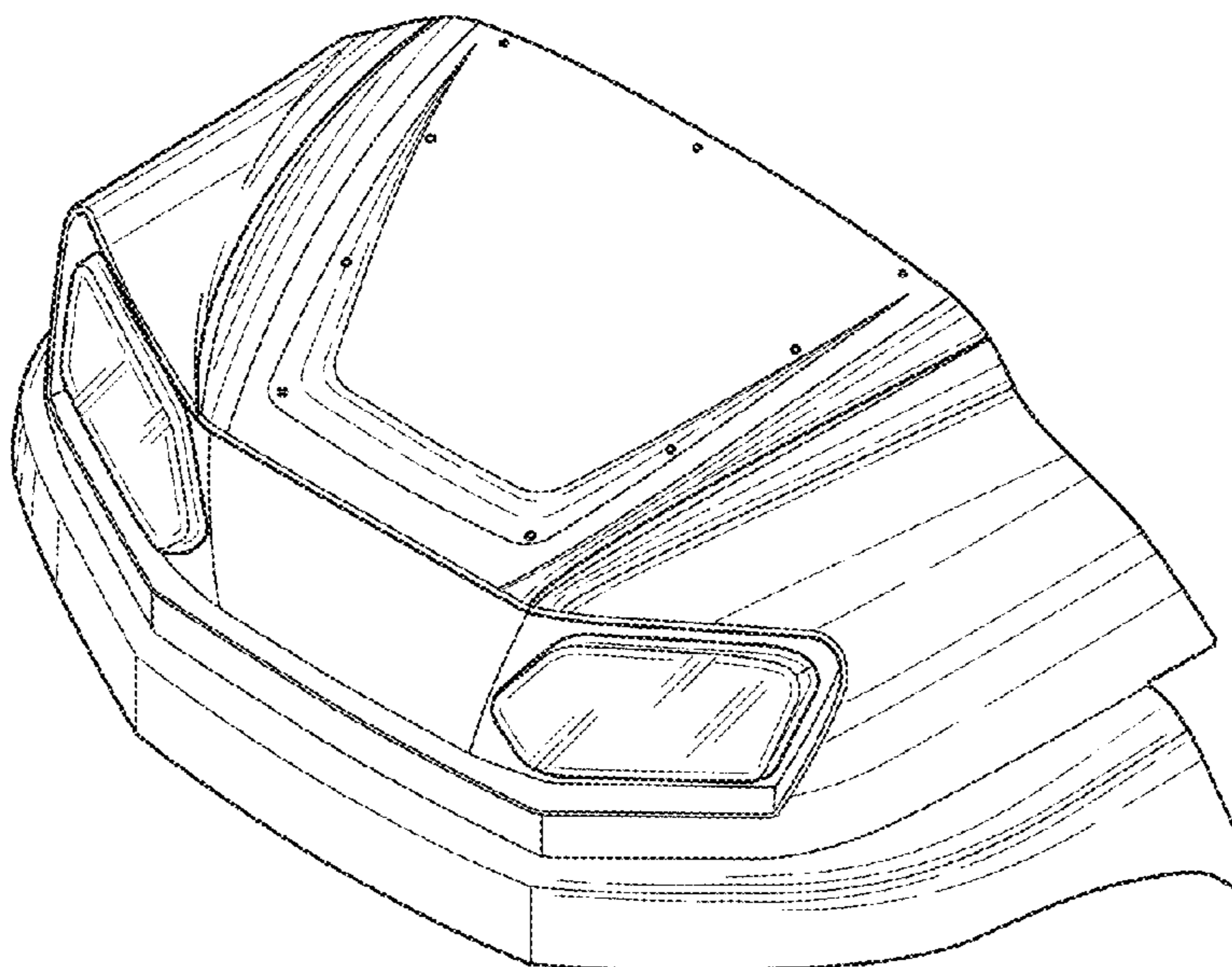

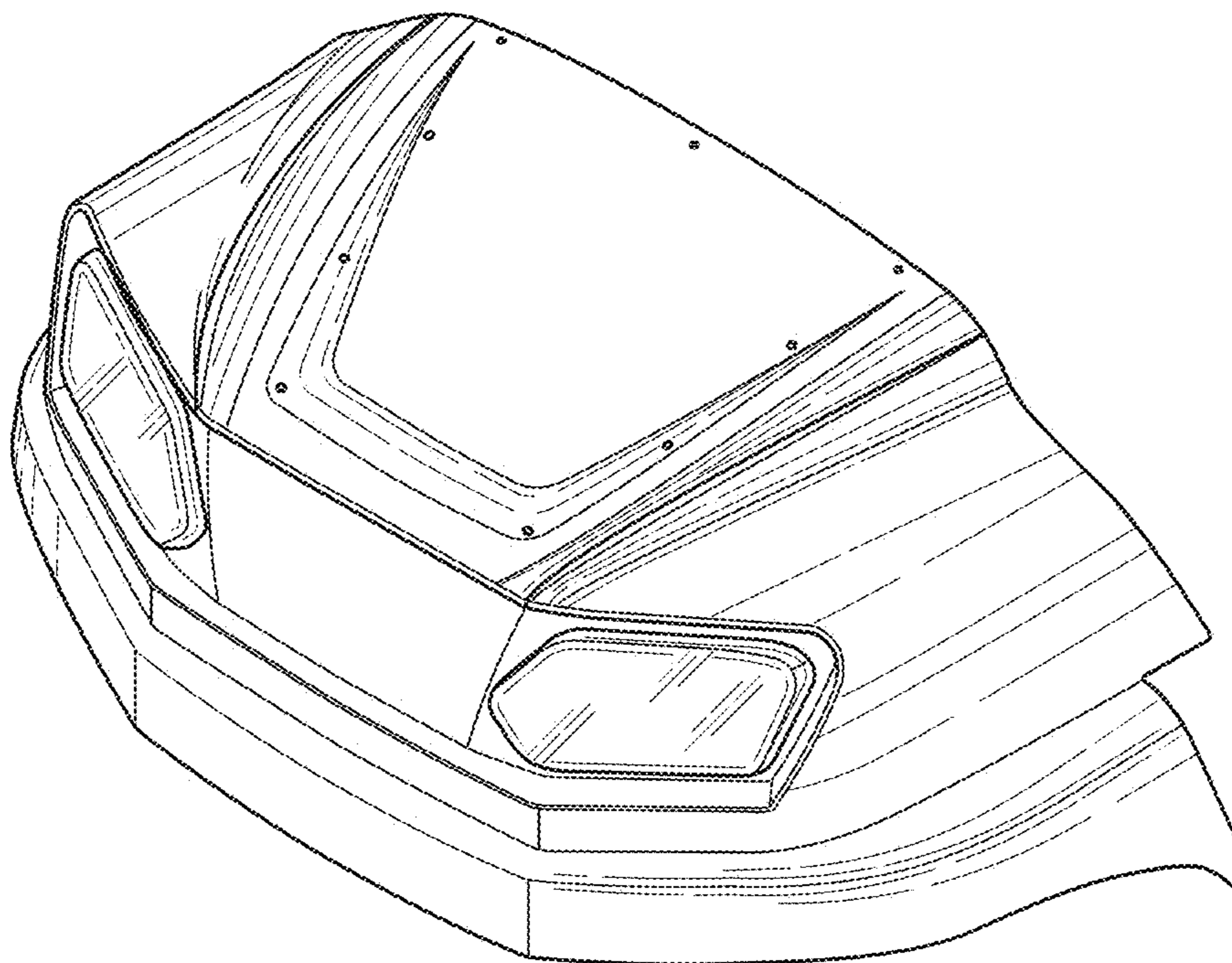

FIG. 1

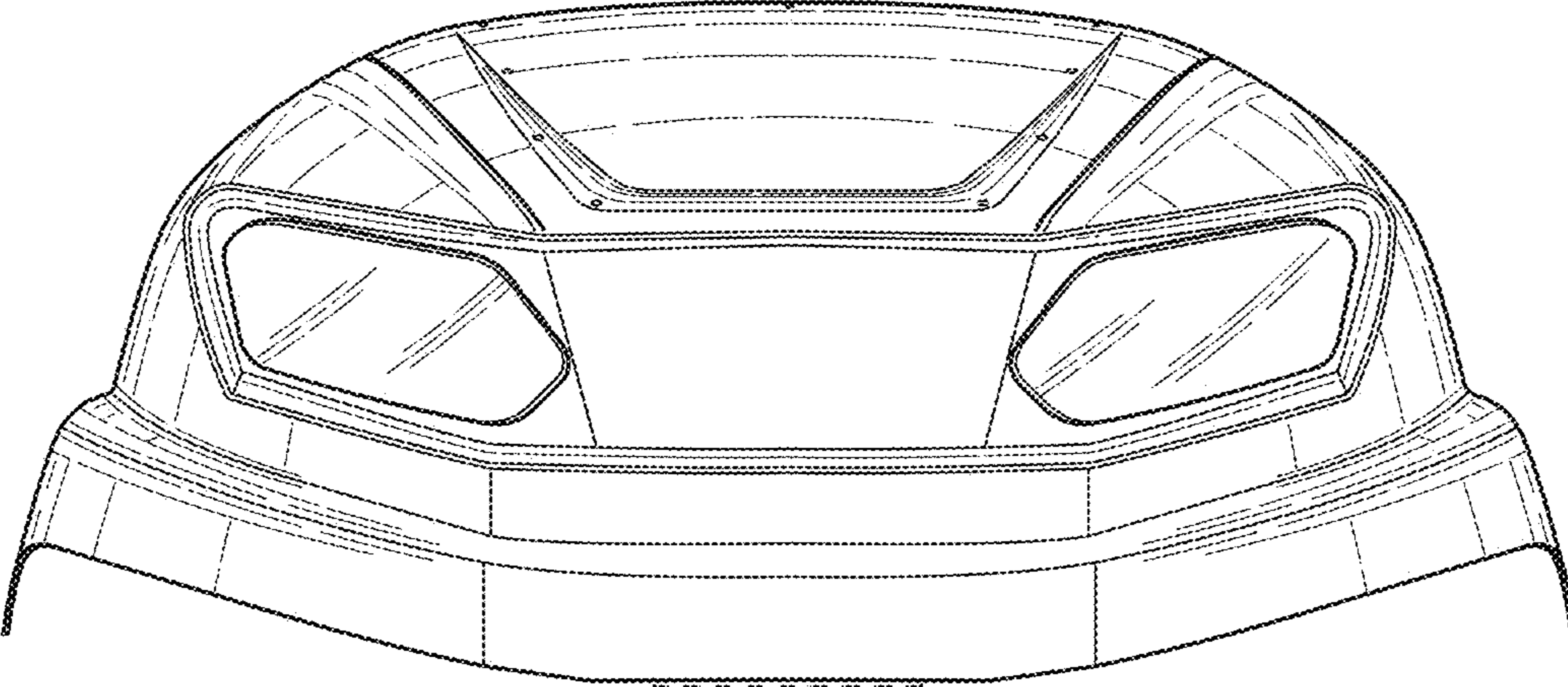

FIG. 2

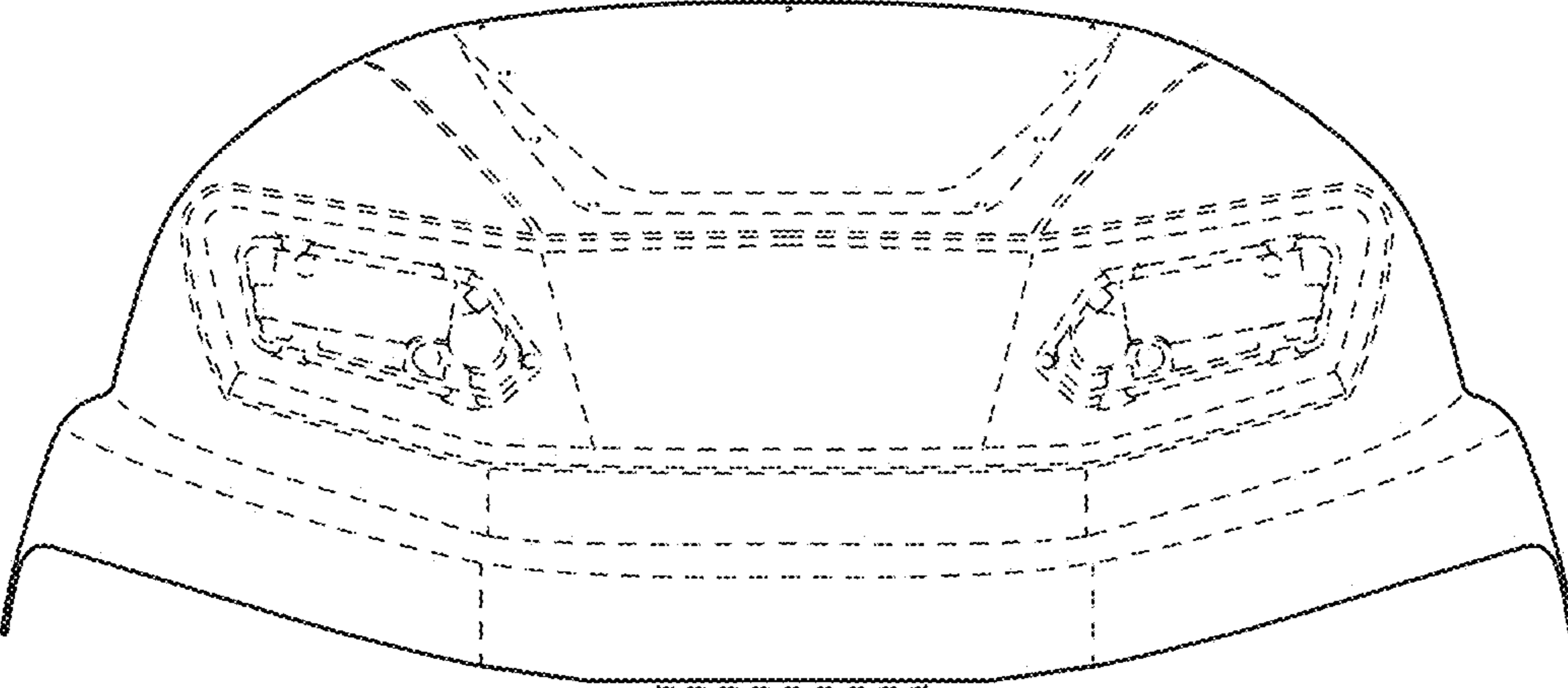

FIG. 3

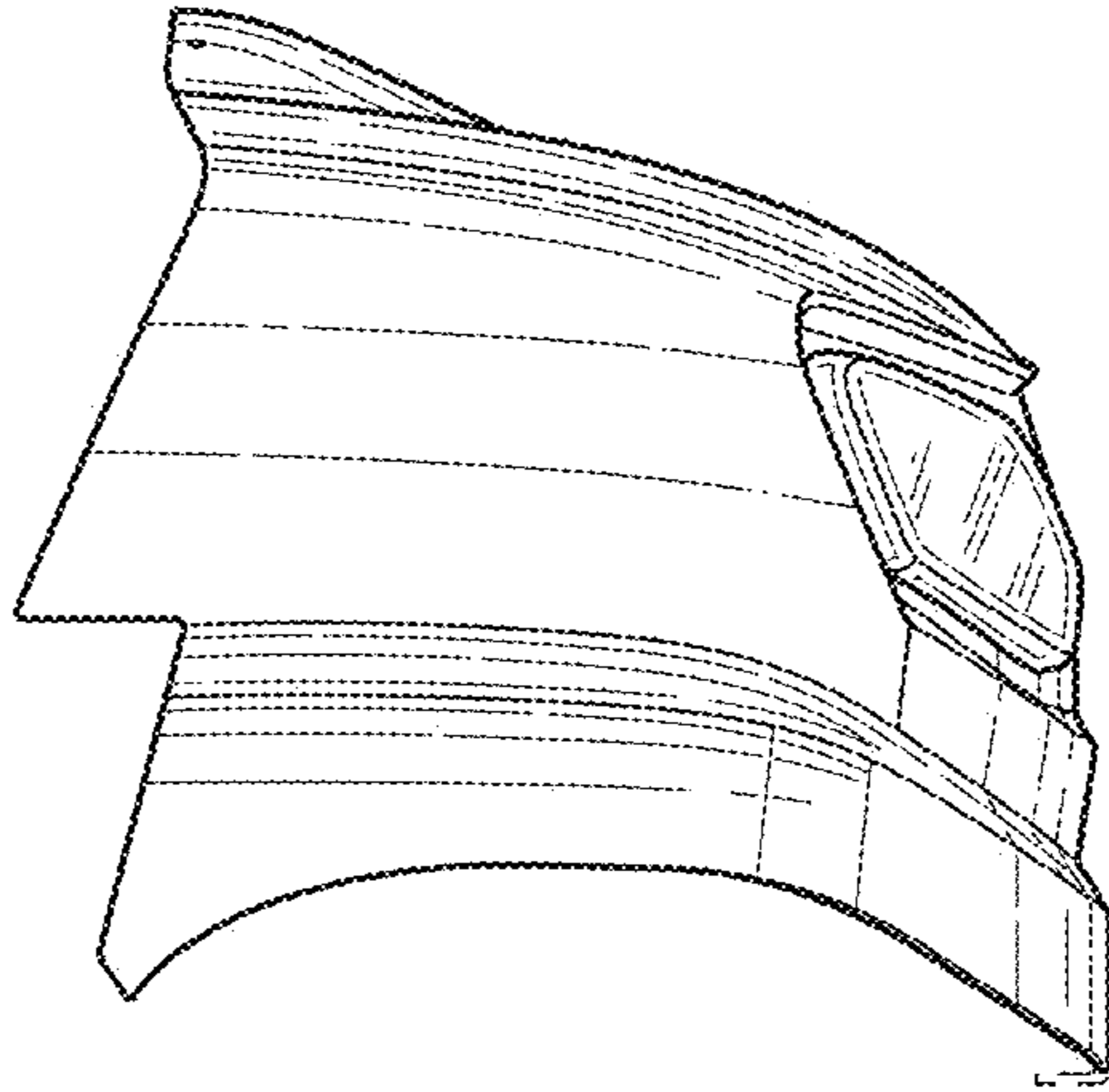

FIG. 4

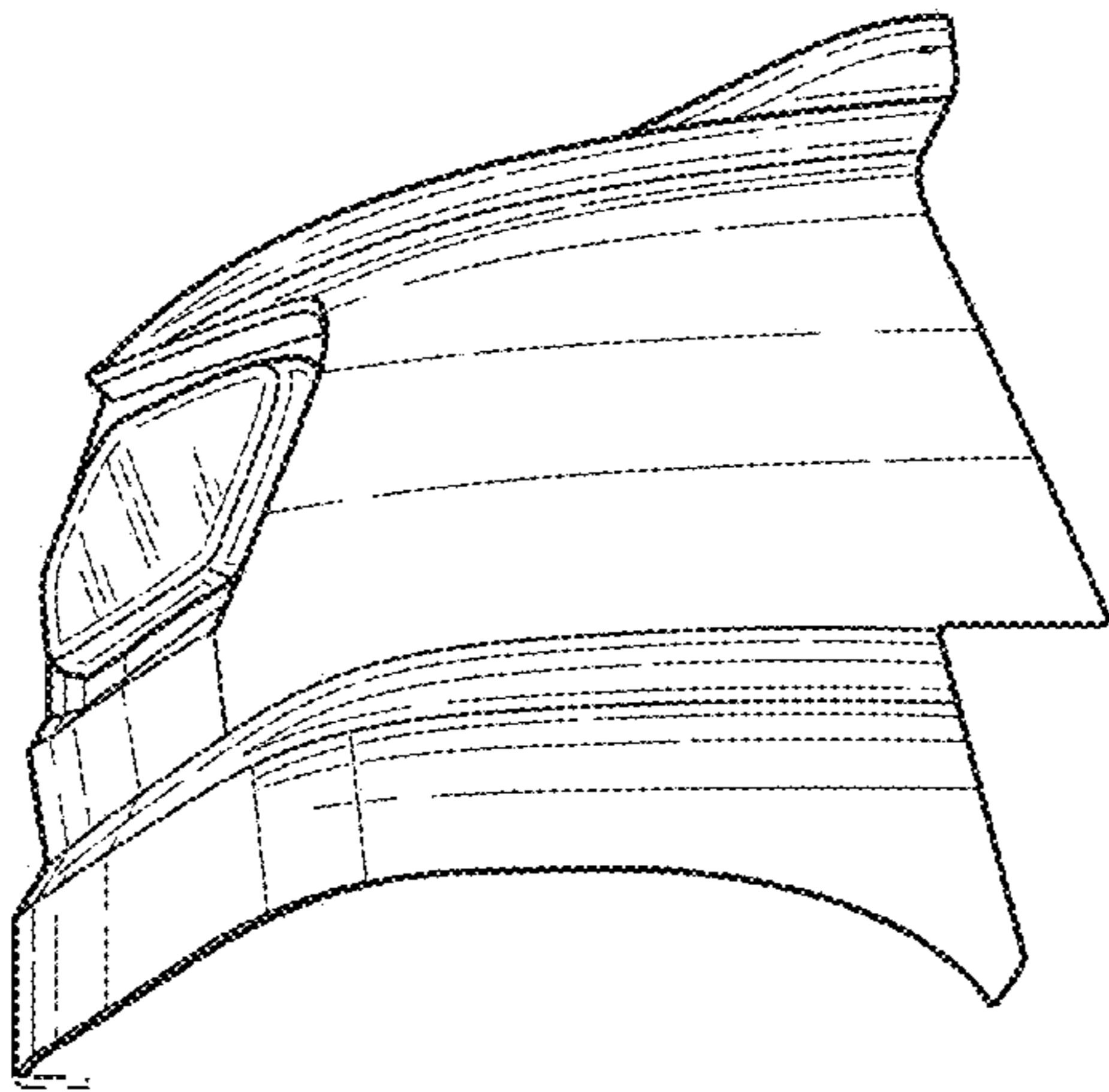

FIG. 5

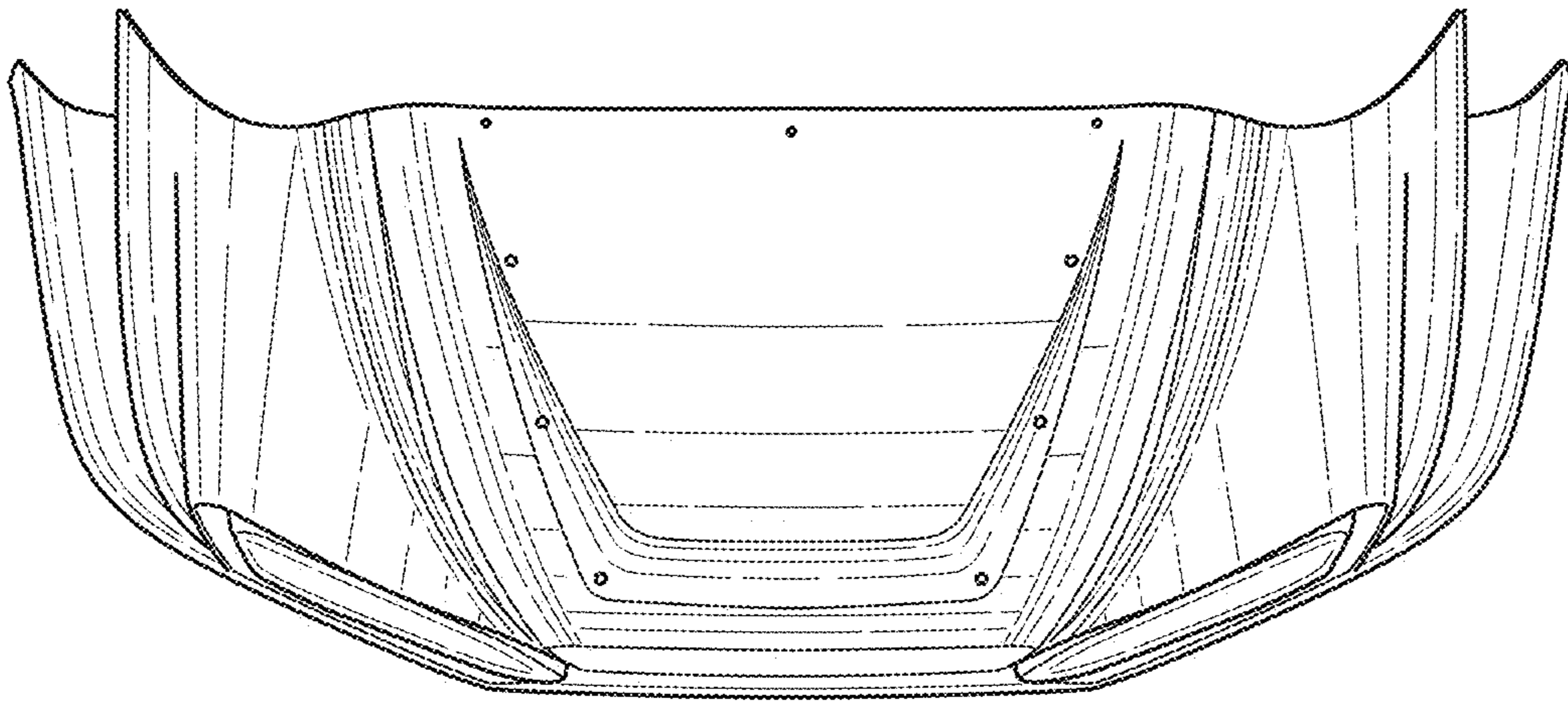

FIG. 6

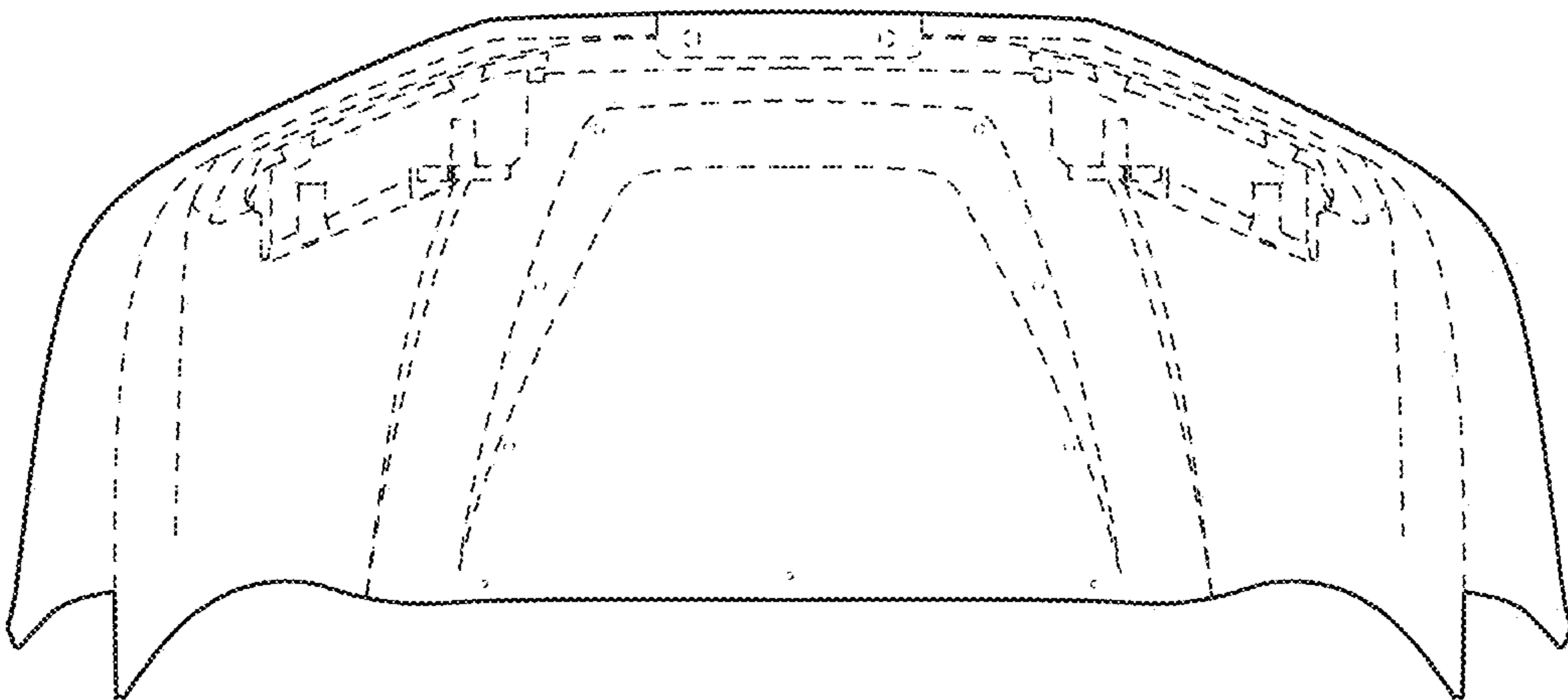

FIG. 7

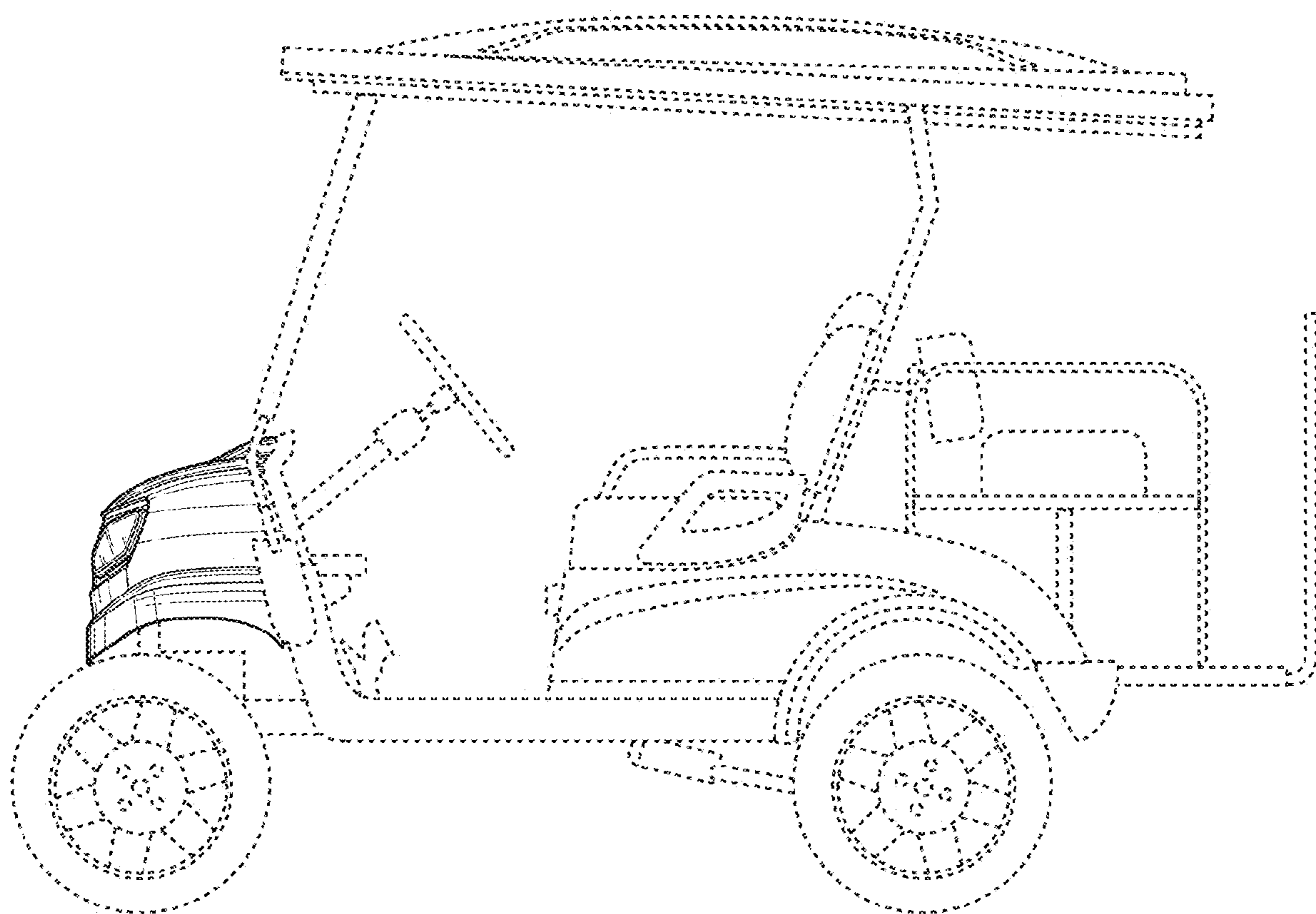

FIG. 8