

US00D965398S

(12) **United States Design Patent** (10) **Patent No.:** **US D965,398 S**
Weise (45) **Date of Patent:** **** Oct. 4, 2022**

(54) **FINGER MOUNTED WRENCH**
(71) Applicant: **Kimber C. Weise**, Elysburg, PA (US)
(72) Inventor: **Kimber C. Weise**, Elysburg, PA (US)
(**) Term: **15 Years**
(21) Appl. No.: **29/770,699**
(22) Filed: **Feb. 16, 2021**
(51) **LOC (13) Cl.** **08-05**
(52) **U.S. Cl.**
USPC **D8/24**
(58) **Field of Classification Search**
USPC D8/14, 16, 17, 21, 24-29, 51, 59, 107;
D24/133, 147; 81/57.13, 57.39, 60
CPC B25B 21/004; B25B 13/46; B25B 13/463
See application file for complete search history.

D398,493 S 9/1998 Jones
6,834,570 B2 12/2004 Risolio
7,299,721 B1 * 11/2007 Eggert B25B 13/065
81/124.2
D633,763 S * 3/2011 Pengra B25B 13/065
D8/28
8,371,190 B2 * 2/2013 Miller B25B 23/12
81/436
D751,878 S * 3/2016 Sullivan D8/25
D756,180 S * 5/2016 Chen A01K 97/18
D8/25

FOREIGN PATENT DOCUMENTS

WO WO2011149727 12/2011
* cited by examiner

Primary Examiner — Rachel A. Voorhies
Assistant Examiner — Benjamin D. Wannemacher

(57) **CLAIM**

The ornamental design for a finger mounted wrench, as shown and described.

(56) **References Cited**

U.S. PATENT DOCUMENTS

1,902,453 A * 3/1933 Kaiser A01K 97/18
172/370
2,418,638 A * 4/1947 Hoover B25F 1/02
81/436
2,543,283 A 2/1951 Frank
2,585,641 A 2/1952 Faso
2,735,321 A * 2/1956 Browne B25G 1/107
81/436
2,986,961 A * 6/1961 Faso B25G 1/107
74/665 GA
3,913,646 A * 10/1975 Grayson B25B 23/08
224/183
4,332,178 A 6/1982 Vukich
D347,983 S * 6/1994 Lee B25G 1/107
D8/25
D368,007 S * 3/1996 Macor D8/25

DESCRIPTION

FIG. 1 is a front view of a finger mounted wrench showing my new design;
FIG. 2 is a rear view of the finger mounted wrench;
FIG. 3 is a right side view of the finger mounted wrench;
FIG. 4 is a left side view of the finger mounted wrench;
FIG. 5 is a top view of the finger mounted wrench;
FIG. 6 is a bottom view of the finger mounted wrench; and,
FIG. 7 is a top front side perspective view of the finger mounted wrench.
The broken lines in FIG. 7 are illustrative of environmental structure forming no part of the claimed design.

1 Claim, 4 Drawing Sheets

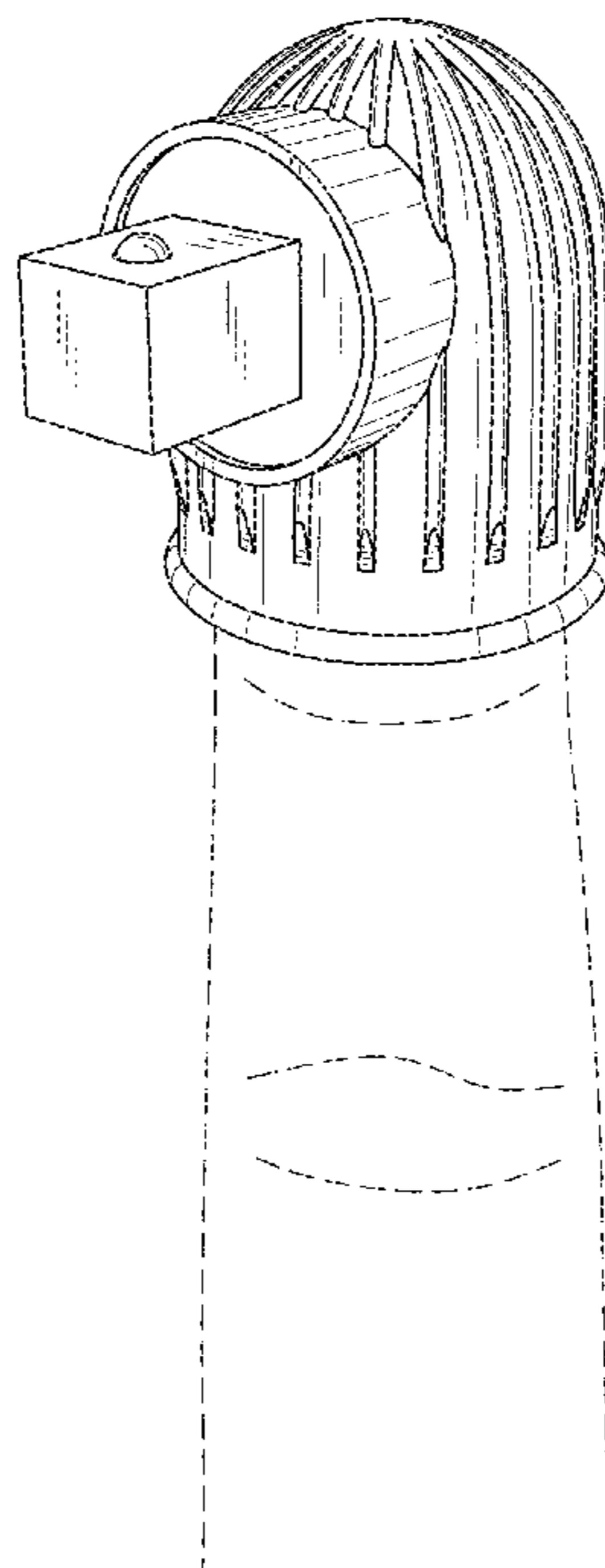

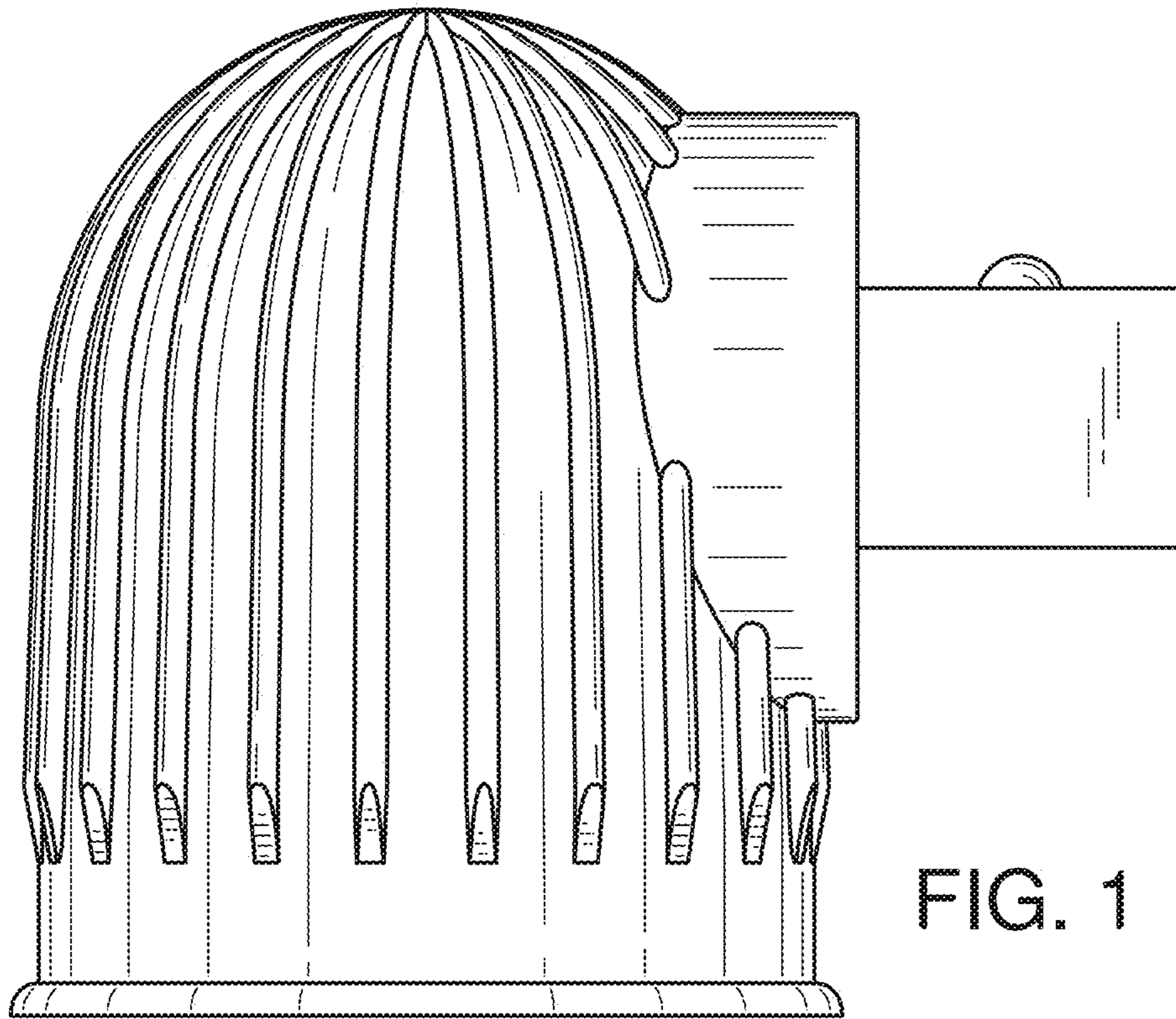

FIG. 1

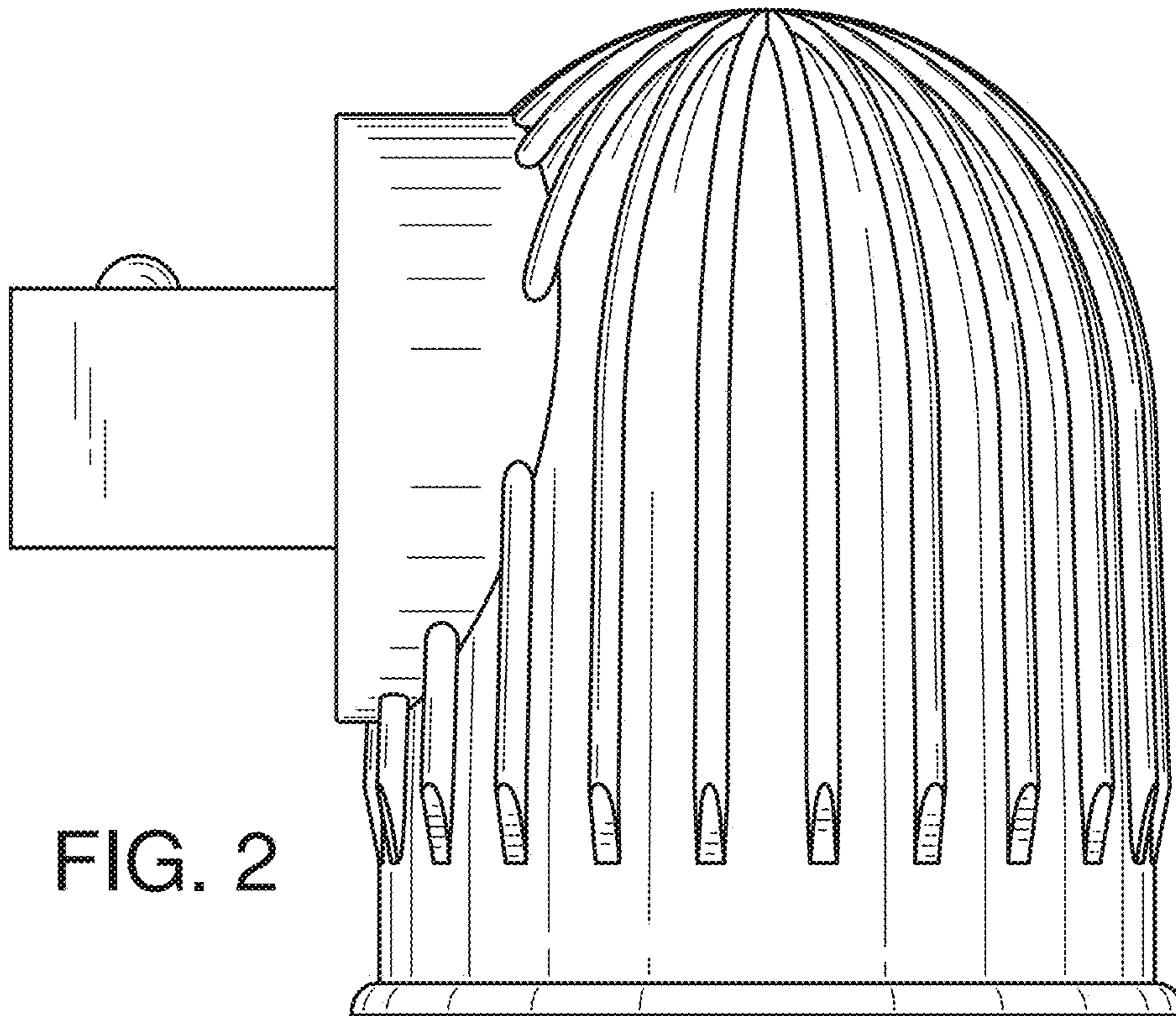

FIG. 2

FIG. 3

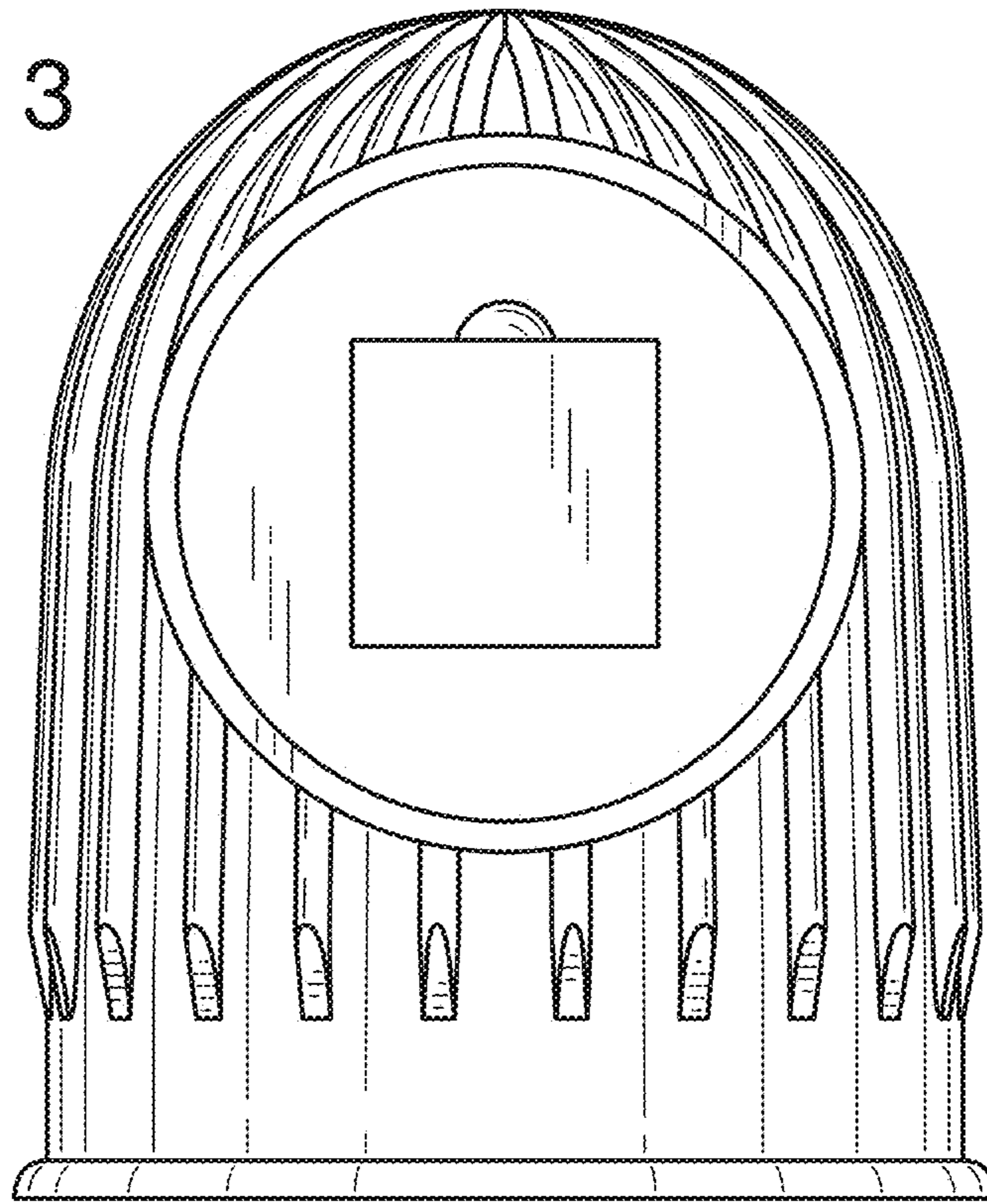

FIG. 4

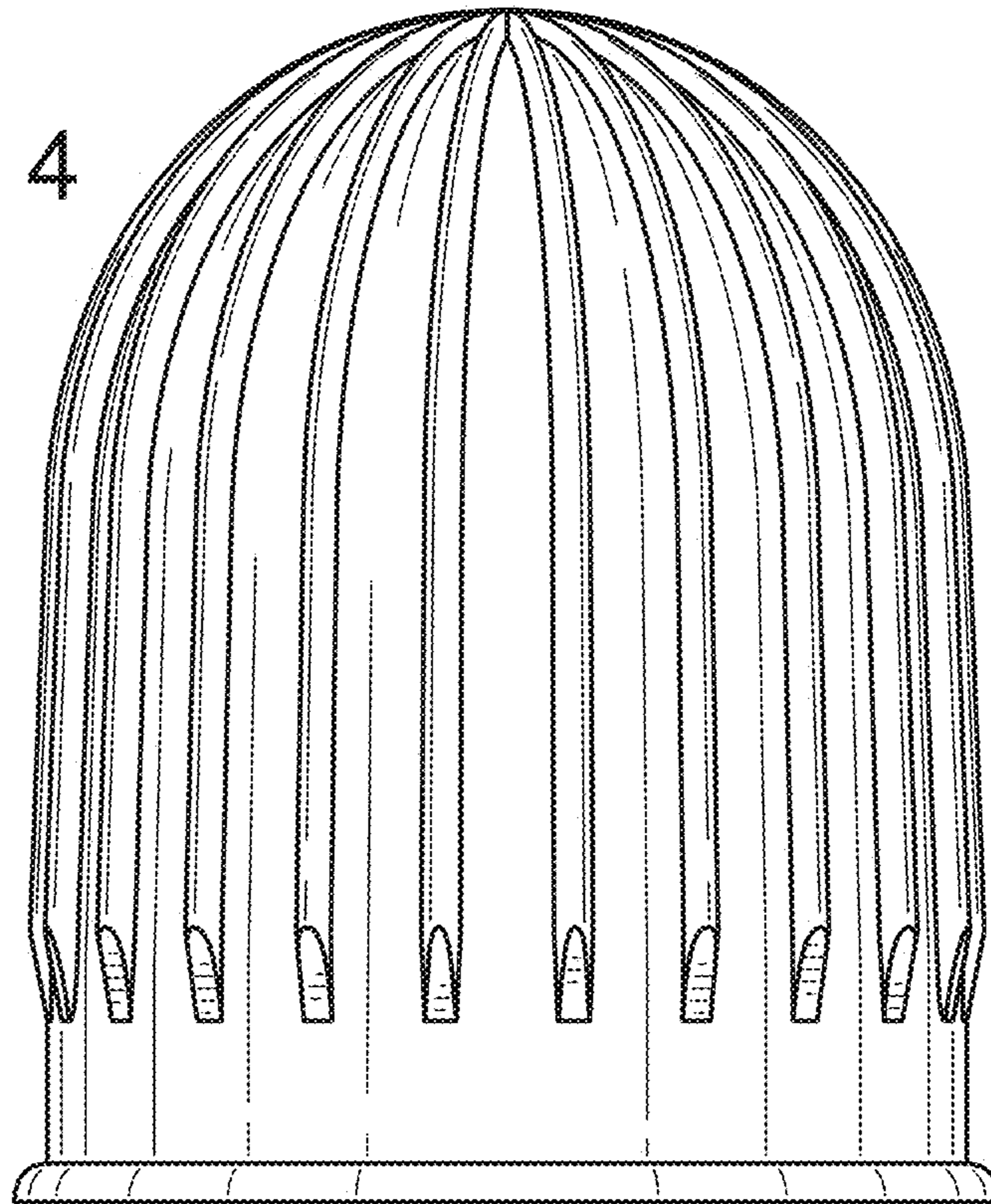

FIG. 5

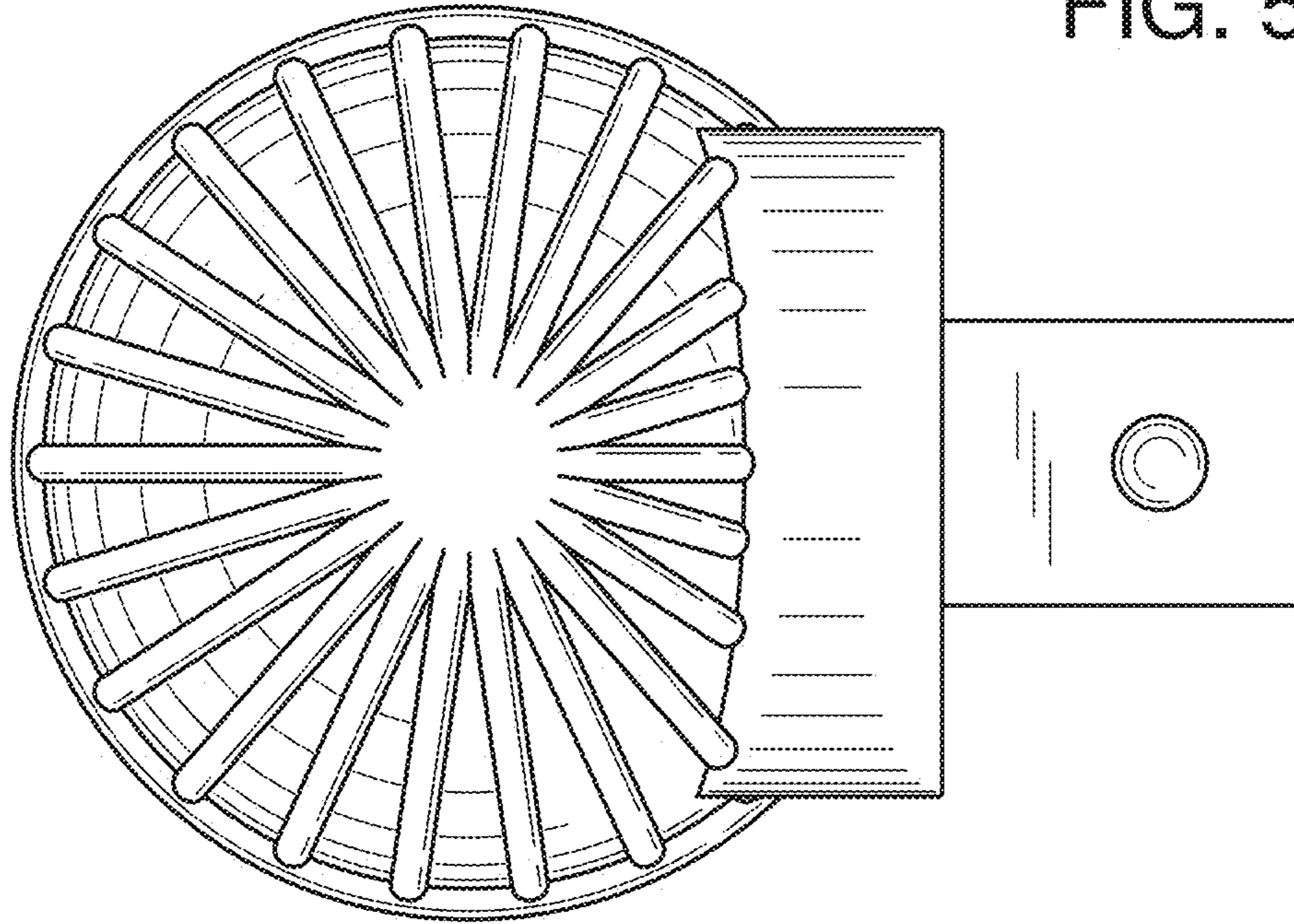

FIG. 6

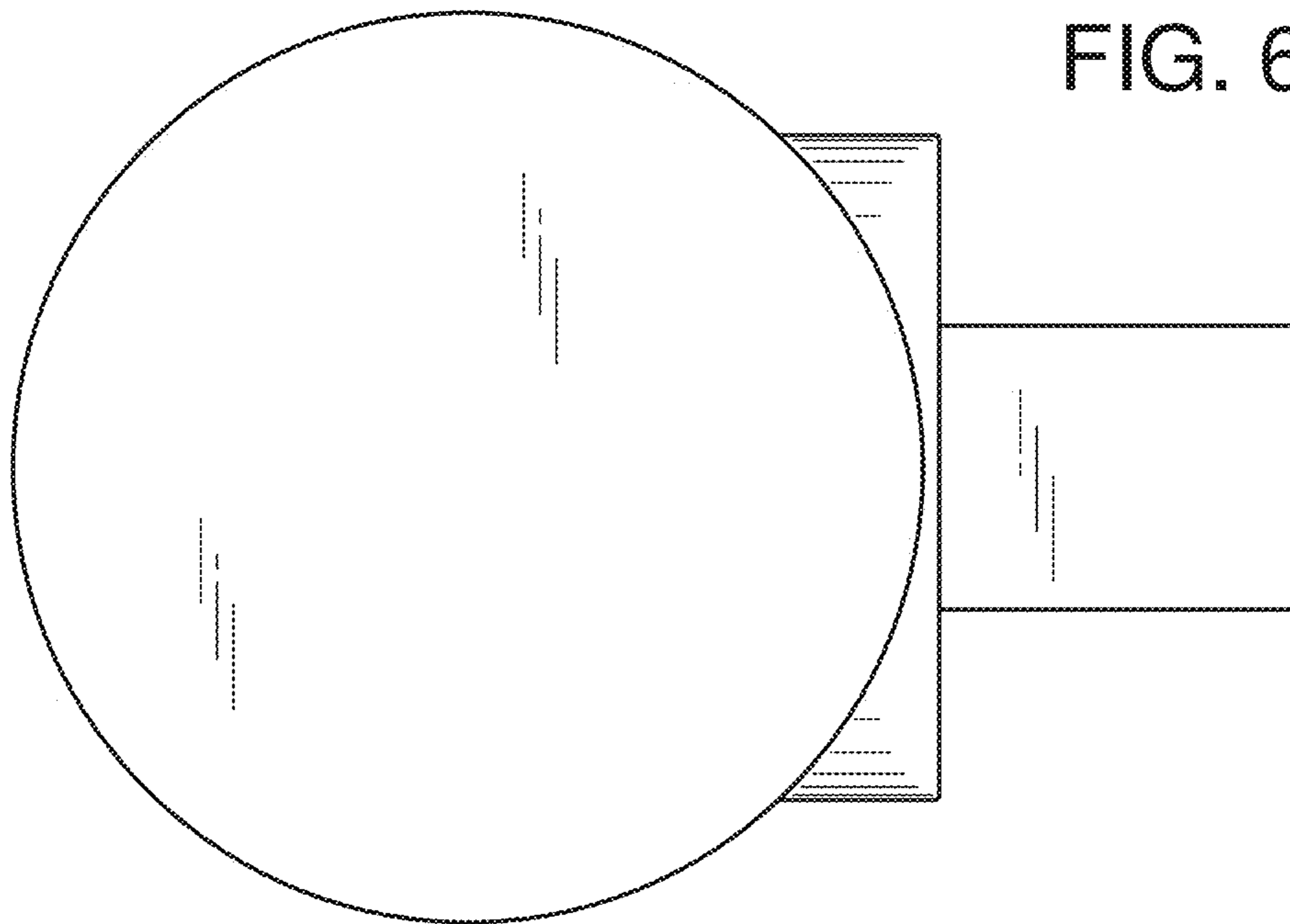

FIG. 7

