

US00D964558S

(12) **United States Design Patent** (10) **Patent No.:** **US D964,558 S**  
**Lewis** (45) **Date of Patent:** **\*\* Sep. 20, 2022**

(54) **BLOOD PRESSURE CONNECTOR**

444,054 A 1/1891 Lazarus  
465,868 A 12/1891 List  
584,008 A 6/1897 Munson  
(Continued)

(71) Applicant: **NORDSON CORPORATION**,  
Westlake, OH (US)

(72) Inventor: **Peter D. Lewis**, Loveland, CO (US)

**FOREIGN PATENT DOCUMENTS**

(73) Assignee: **Nordson Corporation**, Westlake, OH  
(US)

BE 479098 A 1/1948  
CN 1137241 A 12/1996  
(Continued)

(\*\*) Term: **15 Years**

**OTHER PUBLICATIONS**

(21) Appl. No.: **29/670,613**

U.S. Appl. filed Dec. 9, 2009, Lewis et al., U.S. Appl. No. 29/351,665.

(22) Filed: **Nov. 17, 2018**

(Continued)

**Related U.S. Application Data**

(62) Division of application No. 29/582,795, filed on Oct. 31, 2016, now Pat. No. Des. 838,366.

(51) **LOC (13) Cl.** ..... **24-02**

(52) **U.S. Cl.**  
USPC ..... **D24/129**

(58) **Field of Classification Search**  
USPC ..... D24/110.5, 110.6, 128-130, 172;  
D7/397, 387, 398; D8/363, 396  
CPC ..... A61J 1/2048; A61J 1/2013; A61J 1/2055;  
A61J 1/2089; A61J 1/2096; A61M  
16/0816

See application file for complete search history.

(56) **References Cited**

**U.S. PATENT DOCUMENTS**

113,546 A 4/1871 Laughlin  
163,261 A 5/1875 Ruppenthal  
185,896 A 1/1877 Curtis  
187,982 A 3/1877 Pirsson  
200,944 A 3/1878 Smith  
235,426 A 12/1880 Gearon  
235,580 A 12/1880 Smith et al.  
327,509 A 10/1885 Aldridge

*Primary Examiner* — Calvin E Vansant

(74) *Attorney, Agent, or Firm* — BakerHostetler

(57) **CLAIM**

The ornamental design for a blood pressure connector, as shown and described.

**DESCRIPTION**

FIG. 1 is a top perspective view of a male member of a blood pressure connector in a proximal-to-distal orientation according to a third embodiment;  
FIG. 2 is a top perspective view thereof with the male member in a distal-to-proximal orientation;  
FIG. 3 is a top view thereof with the male member in the proximal-to-distal orientation;  
FIG. 4 is a bottom view thereof with the male member in the distal-to-proximal orientation;  
FIG. 5 is a side view thereof with the male member in the proximal-to-distal orientation;  
FIG. 6 is a side view thereof with the male member in the distal-to-proximal orientation;  
FIG. 7 is a distal end view thereof; and,  
FIG. 8 is a proximal end view thereof.  
The dashed broken lines depict portions of the blood pressure connector that form no part of the claimed design.

**1 Claim, 8 Drawing Sheets**

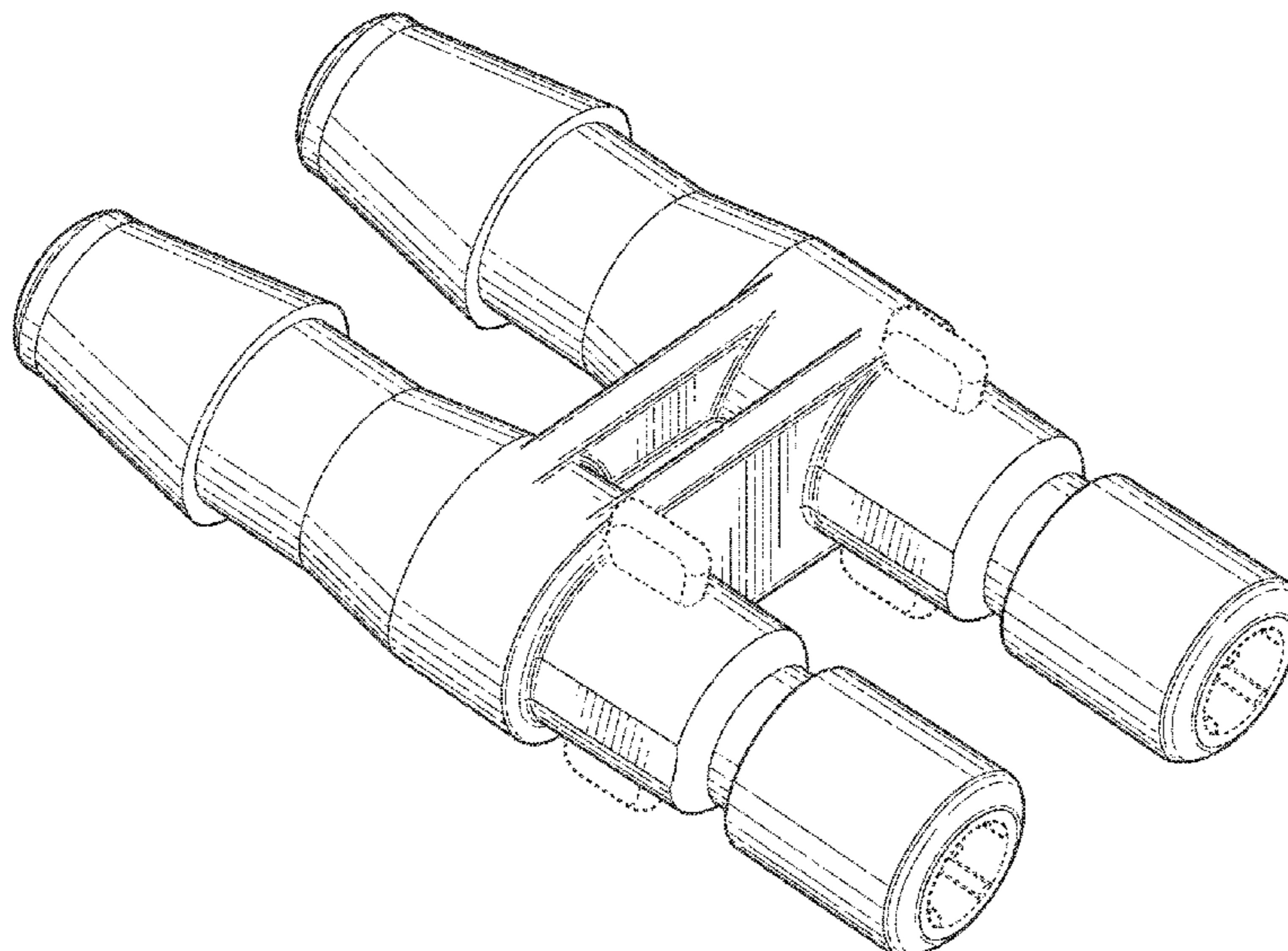

(56)

## References Cited

## U.S. PATENT DOCUMENTS

707,991 A	8/1902	Wareham	2,774,616 A	12/1956	Dodd et al.
725,421 A	4/1903	Dinkins	2,790,571 A	4/1957	Donald et al.
727,982 A	5/1903	Ludwig	2,790,671 A	4/1957	Kenworthy
874,957 A	12/1907	Godley	2,864,628 A	12/1958	Edleson
884,461 A	4/1908	Browne	D185,896 S	8/1959	Johnson
909,131 A	1/1909	Antic	2,915,325 A	12/1959	Foster
951,889 A	3/1910	Teuer	2,926,934 A	3/1960	Gill
D42,368 S	3/1912	Mossberg	2,931,668 A	4/1960	Baley
1,029,819 A	6/1912	Nylander	D187,982 S	5/1960	Pirsson et al.
1,033,187 A	7/1912	Metzger	2,935,338 A	5/1960	Mills, Jr.
1,039,354 A	9/1912	Bonadio	2,937,892 A	5/1960	Prescott, Jr.
1,077,417 A	11/1913	McCracken	2,948,553 A	8/1960	Gill et al.
1,078,112 A	11/1913	Storm	2,967,067 A	1/1961	Singer
1,115,945 A	11/1914	Kunz	2,991,090 A	7/1961	De Cenzo
1,115,989 A	11/1914	Thurman	3,017,203 A	1/1962	Macleod
1,193,446 A	8/1916	Wells	3,037,497 A	6/1962	Harter
1,239,345 A	9/1917	Brown	3,046,028 A	7/1962	Nathan
1,255,847 A	2/1918	Arkin	3,048,415 A	8/1962	Shook
1,259,684 A	3/1918	Vinten	3,073,342 A	1/1963	Magorien
1,489,310 A	4/1924	Coe	3,078,068 A	2/1963	Romney
1,526,218 A	2/1925	Johnson	D196,473 S	10/1963	Hill
1,578,504 A	3/1926	Bronson et al.	3,124,157 A	3/1964	Krzewina
1,587,079 A	6/1926	Shigetake	3,129,020 A	4/1964	Bujnowski
1,767,073 A	6/1930	Ingold	3,171,196 A	3/1965	Helitas
1,863,360 A	6/1932	Weatherhead, Jr.	3,191,628 A	6/1965	Kirkwood et al.
1,950,947 A	3/1934	Mulroyan	3,217,400 A	11/1965	Otto et al.
2,023,428 A	12/1935	Liebhardt	3,217,771 A	11/1965	Nathan et al.
2,056,524 A	10/1936	Johnson	3,227,380 A	1/1966	Pinkston
2,066,473 A	1/1937	Berg	3,237,974 A	3/1966	Press
2,066,624 A	1/1937	Hem	3,245,703 A	4/1966	Manly
2,097,628 A	11/1937	Charles	3,276,799 A	10/1966	Moore et al.
2,099,335 A	11/1937	Hansen	3,279,497 A	10/1966	Frederick et al.
2,099,336 A	11/1937	Hart	3,280,526 A	10/1966	Ambrose
2,108,714 A	2/1938	Peter et al.	3,314,696 A	4/1967	Ferguson et al.
2,116,705 A	5/1938	Franz et al.	3,317,214 A	5/1967	Durgom
2,116,706 A	5/1938	Meohas	D209,166 S	11/1967	Hunt
2,139,745 A	12/1938	Goodall	D209,168 S	11/1967	Hunt
2,139,746 A	12/1938	Hadaway	3,352,576 A	11/1967	Thorne-Thomsen
2,147,355 A	2/1939	Scholtes	3,382,892 A	5/1968	Cerbin
2,147,366 A	2/1939	Fagan et al.	3,394,954 A	7/1968	Sarns
2,159,116 A	5/1939	Zacharias	3,403,930 A	10/1968	Bernier
2,169,116 A	8/1939	Thompson	3,432,176 A	3/1969	Valenziano
2,211,147 A	8/1940	Miller	3,448,760 A	6/1969	Cranage
2,257,321 A	9/1941	Arnold	3,450,424 A	6/1969	Calisher
2,263,293 A	11/1941	Ewald	3,512,808 A	5/1970	Graham
2,264,815 A	12/1941	Alecander	3,523,701 A	8/1970	Graham
2,264,816 A	12/1941	Treanor	3,538,940 A	11/1970	Graham
2,267,321 A	12/1941	Biddlecomb et al.	3,542,338 A	11/1970	Scaramucci
2,340,119 A	1/1944	Graham	3,545,490 A	12/1970	Burrus
2,346,445 A	4/1944	Herman et al.	3,550,626 A	12/1970	Daniels et al.
2,346,446 A	4/1944	Messier	3,560,027 A	2/1971	Graham
2,352,728 A	7/1944	Herman et al.	3,563,265 A	2/1971	Graham
2,362,728 A	11/1944	Smith	3,574,314 A	4/1971	Quercia
2,429,782 A	10/1947	Versoy	3,588,149 A	6/1971	Demler et al.
2,432,946 A	12/1947	Theunissen	3,596,933 A	8/1971	Luckenbill
2,470,800 A	5/1949	Ashton	3,599,843 A	8/1971	Johnston
2,479,499 A	8/1949	Le Clair	3,600,917 A	8/1971	Krock
2,500,720 A	3/1950	Der Heem	3,649,050 A	3/1972	Woodling
2,507,536 A	5/1950	Goodson	3,666,297 A	5/1972	Marks
2,516,583 A	7/1950	Maurice	3,690,336 A	9/1972	Drum
2,535,740 A	12/1950	Knopp	3,712,583 A	1/1973	Martindale et al.
D163,261 S	5/1951	Desguin et al.	3,747,964 A	7/1973	Nilsen
2,577,009 A	12/1951	Frantz	3,750,238 A	8/1973	Tanner
2,600,720 A	6/1952	Abramson	3,815,887 A	6/1974	Curtis et al.
2,607,636 A	8/1952	Michelsen	3,817,561 A	6/1974	Kay
2,616,683 A	11/1952	Fevre, Jr.	3,829,135 A	8/1974	Forni
2,626,974 A	1/1953	Howard et al.	3,873,062 A	3/1975	Johnson et al.
2,630,131 A	3/1953	Rush	3,876,234 A	4/1975	Harms
2,636,740 A	4/1953	McNeal	D235,426 S	6/1975	Foster
2,661,018 A	12/1953	Rush	3,889,710 A	6/1975	Brost
2,677,009 A	4/1954	Mascuch	3,899,200 A	8/1975	Gamble
2,701,147 A	2/1955	Summerville	3,921,656 A	11/1975	Meisenheimer et al.
2,722,399 A	11/1955	Hans	3,948,547 A	4/1976	Gache
2,753,195 A	7/1956	Palmer	3,979,934 A	9/1976	Isenmann
2,763,196 A	9/1956	Singleton	3,990,674 A	11/1976	Schattenberg
			3,995,659 A	12/1976	Cantore
			4,025,049 A	5/1977	Schmidt
			4,039,213 A	8/1977	Walters
			4,072,330 A	2/1978	Brysch



(56)

## References Cited

## U.S. PATENT DOCUMENTS

4,099,748 A	7/1978	Kavick	4,776,067 A	10/1988	Sorensen
4,113,627 A	9/1978	Leason	4,790,567 A	12/1988	Kawano et al.
4,116,476 A	9/1978	Porter et al.	4,790,569 A	12/1988	Chaffee
4,129,145 A	12/1978	Wynn	4,792,115 A	12/1988	Jindra et al.
4,139,222 A	2/1979	Loland	4,793,637 A	12/1988	Laipply et al.
4,142,546 A	3/1979	Sandau	4,806,123 A	2/1989	Konishi et al.
D252,470 S	7/1979	Pawlak	D300,361 S	3/1989	Tokarz
4,181,149 A	1/1980	Cox	4,824,148 A	4/1989	Grabowski
4,182,519 A	1/1980	Wilson	4,827,921 A	5/1989	Rugheimer
D254,505 S	3/1980	Parsons et al.	4,832,237 A	5/1989	Hurford, Jr.
4,200,605 A	4/1980	Imamura et al.	4,834,423 A	5/1989	Deland
D255,145 S	5/1980	Nederman	4,844,512 A	7/1989	Gahwiler
4,220,360 A	9/1980	Jacek et al.	4,863,201 A	9/1989	Carstens
D258,526 S	3/1981	Nederman	4,863,202 A	9/1989	Oldford
4,253,687 A	3/1981	Maples	4,896,402 A	1/1990	Jansen et al.
D259,278 S	5/1981	McCaw et al.	4,900,065 A	2/1990	Houck
4,271,865 A	6/1981	Galloway et al.	4,903,995 A	2/1990	Blenkush et al.
4,282,175 A	8/1981	Volgstadt et al.	4,923,228 A	5/1990	Laipply
4,287,644 A	9/1981	Durand	4,928,859 A	5/1990	Krahn et al.
4,290,434 A	9/1981	Jewett	4,928,999 A	5/1990	Landriault et al.
4,294,285 A	10/1981	Joslyn	4,934,655 A	6/1990	Blenkush et al.
4,296,949 A	10/1981	Muetterties et al.	4,935,992 A	6/1990	Due
4,319,774 A	3/1982	Kavick	4,946,200 A	8/1990	Blenkush et al.
4,330,010 A	5/1982	Drescher et al.	4,946,204 A	8/1990	Boticki
4,330,142 A	5/1982	Paini	4,949,745 A	8/1990	McKeon
4,331,175 A	5/1982	Brake et al.	4,966,398 A	10/1990	Peterson
4,331,177 A	5/1982	Makishima	4,969,879 A	11/1990	Lichte
4,340,200 A	7/1982	Stegmeier	D313,067 S	12/1990	Kotake et al.
4,345,786 A	8/1982	Egert	D313,277 S	12/1990	Haining
4,346,703 A	8/1982	Dennehey et al.	D314,050 S	1/1991	Yoshihisa
4,351,351 A	9/1982	Flory et al.	D314,233 S	1/1991	Medvick
4,366,816 A	1/1983	Bayard et al.	4,982,736 A	1/1991	Schneider
4,393,548 A	7/1983	Herb	4,991,880 A	2/1991	Bernart
4,397,442 A	8/1983	Larkin	5,009,252 A	4/1991	Faughn
4,407,526 A	10/1983	Cicenas	5,015,014 A	5/1991	Sweeney
4,431,031 A	2/1984	Ettlinger	5,029,908 A	7/1991	Belisaire
4,431,218 A	2/1984	Paul et al.	5,033,777 A	7/1991	Blenkush
4,434,121 A	2/1984	Schaeper	D319,312 S	8/1991	Schneider
4,436,125 A	3/1984	Blenkush	5,052,725 A	10/1991	Meyer et al.
4,437,689 A	3/1984	Goebel et al.	5,074,601 A	12/1991	Spors et al.
4,439,188 A	3/1984	Dennehey et al.	5,076,615 A	12/1991	Sampson
4,458,719 A	7/1984	Strybel	5,078,429 A	1/1992	Braut et al.
4,489,914 A	12/1984	Stevenson et al.	5,085,472 A	2/1992	Guest
4,489,961 A	12/1984	Laidig	5,090,448 A	2/1992	Truchet
4,500,118 A	2/1985	Blenkush	5,090,747 A	2/1992	Kotake
4,501,280 A	2/1985	Hood, Jr.	5,094,482 A	3/1992	Petty et al.
4,527,745 A	7/1985	Butterfield et al.	5,104,158 A	4/1992	Meyer et al.
4,541,457 A	9/1985	Blenkush	5,106,127 A	4/1992	Briet
4,541,657 A	9/1985	Smyth	D326,155 S	5/1992	Boehringer et al.
4,553,587 A	11/1985	Traylor	5,110,163 A	5/1992	Benson et al.
D282,962 S	3/1986	Gerber	5,112,084 A	5/1992	Washizu
4,576,359 A	3/1986	Oetiker	5,114,250 A	5/1992	Usui
4,580,816 A	4/1986	Campbell et al.	D326,715 S	6/1992	Schmidt
4,603,888 A	8/1986	Goodall et al.	D327,509 S	6/1992	Leblanc
4,603,890 A	8/1986	Huppee	5,123,677 A	6/1992	Kreczko et al.
4,613,112 A	9/1986	Philipot et al.	5,143,381 A	9/1992	Temple
4,616,859 A	10/1986	Brunet	5,160,177 A	11/1992	Washizu
4,626,001 A	12/1986	Lee	5,160,474 A	11/1992	Huff
4,630,847 A	12/1986	Blenkush	5,165,733 A	11/1992	Sampson
4,632,436 A	12/1986	Kimura	5,169,161 A	12/1992	Jones
4,635,972 A	1/1987	Lyll	D332,482 S	1/1993	Petty et al.
4,645,245 A	2/1987	Cunningham	5,176,406 A	1/1993	Straghan
4,658,326 A	4/1987	Clark et al.	5,178,303 A	1/1993	Blenkush et al.
4,659,116 A	4/1987	Cameron	5,181,752 A	1/1993	Benson et al.
4,694,544 A	9/1987	Chapman	D333,178 S	2/1993	Novy
4,698,027 A	10/1987	Vandame	5,190,224 A	3/1993	Hamilton
4,699,298 A	10/1987	Grant et al.	5,201,552 A	4/1993	Hohmann et al.
4,700,926 A	10/1987	Hansen	5,219,185 A	6/1993	Oddenino
4,703,957 A	11/1987	Blenkush	5,222,279 A	6/1993	Franco et al.
4,706,847 A	11/1987	Sankey et al.	5,228,724 A	7/1993	Godeau
4,712,280 A	12/1987	Fildan	5,232,020 A	8/1993	Mason et al.
4,733,890 A	3/1988	Vyse	D339,417 S	9/1993	Sampson et al.
4,738,401 A	4/1988	Filicicchia	5,251,025 A	10/1993	Cooper et al.
4,753,268 A	6/1988	Palau	5,273,053 A	12/1993	Pohndorf
4,768,558 A	9/1988	Weber	5,297,820 A	3/1994	Martin
			5,297,826 A	3/1994	Percebois et al.
			5,316,041 A	5/1994	Ramacier et al.
			5,318,332 A	6/1994	Hohmann et al.
			5,330,235 A	7/1994	Wagner et al.



(56)

## References Cited

## U.S. PATENT DOCUMENTS

5,341,773 A	8/1994	Schulte et al.	5,957,898 A	9/1999	Jepson et al.
5,348,051 A	9/1994	Kallenbach	5,961,157 A	10/1999	Baron et al.
5,348,354 A	9/1994	Badoureaux	5,964,485 A	10/1999	Hame et al.
5,353,836 A	10/1994	Decler et al.	5,965,077 A	10/1999	Rowley et al.
5,356,183 A	10/1994	Cole	5,975,489 A	11/1999	Decler et al.
5,374,088 A	12/1994	Moretti et al.	5,984,378 A	11/1999	Ostrander et al.
5,385,311 A	1/1995	Morikawa et al.	5,988,704 A	11/1999	Ryhman
5,385,331 A	1/1995	Allread et al.	6,012,743 A	1/2000	Godeau et al.
D357,307 S	4/1995	Ramacier, Jr. et al.	6,015,171 A	1/2000	Schorn
5,405,333 A	4/1995	Richmond	D419,861 S	2/2000	Khokhar
5,405,339 A	4/1995	Kohnen et al.	6,019,348 A	2/2000	Powell
5,405,340 A	4/1995	Fageol et al.	6,024,124 A	2/2000	Braun et al.
5,411,300 A	5/1995	Mitsui	6,029,701 A	2/2000	Chaffardon et al.
5,417,442 A	5/1995	Joernhagen	6,032,691 A	3/2000	Powell et al.
5,421,622 A	6/1995	Godeau	6,041,805 A	3/2000	Gydesen et al.
5,437,650 A	8/1995	Larkin et al.	D422,487 S	4/2000	Khokhar
5,440,792 A	8/1995	Ida	6,050,297 A	4/2000	Ostrowski et al.
5,462,313 A	10/1995	Rea et al.	6,076,234 A	6/2000	Khokhar et al.
5,494,074 A	2/1996	Ramacier et al.	6,077,245 A	6/2000	Heinrich et al.
D369,409 S	4/1996	Salter	6,077,259 A	6/2000	Caizza et al.
5,507,733 A	4/1996	Larkin et al.	6,082,401 A	7/2000	Braun et al.
5,511,527 A	4/1996	Lorraine et al.	6,086,044 A	7/2000	Guest
D372,093 S	7/1996	Sampson et al.	6,089,540 A	7/2000	Heinrichs et al.
5,533,996 A	7/1996	Murphey et al.	6,095,983 A	8/2000	Wawro
5,536,258 A	7/1996	Folden	6,099,045 A	8/2000	Pirona
5,542,712 A	8/1996	Klinger et al.	6,112,855 A	9/2000	Camacho et al.
5,547,166 A	8/1996	Engdahl	6,123,690 A	9/2000	Mejslov
5,547,230 A	8/1996	Bank et al.	6,129,390 A	10/2000	Ohlsson
5,553,895 A	9/1996	Karl et al.	6,135,150 A	10/2000	Powell et al.
D375,160 S	10/1996	Sampson et al.	6,135,992 A	10/2000	Wang
5,568,946 A	10/1996	Jackowski	6,142,538 A	11/2000	Volgstadt et al.
5,595,217 A	1/1997	Gillen et al.	6,145,896 A	11/2000	Vitel et al.
5,601,317 A	2/1997	Crouse et al.	6,152,914 A	11/2000	Van et al.
5,607,087 A	3/1997	Wery et al.	6,155,610 A	12/2000	Godeau et al.
5,607,190 A	3/1997	Exandier et al.	6,161,578 A	12/2000	Braun et al.
5,617,609 A	4/1997	Bently	6,176,523 B1	1/2001	Winslett
5,620,025 A	4/1997	Lewin	6,182,694 B1	2/2001	Sievers et al.
5,628,726 A	5/1997	Cotter	6,189,560 B1	2/2001	Reynolds
D380,262 S	6/1997	Van Funderburk et al.	6,199,915 B1	3/2001	Becker
5,639,064 A	6/1997	Decler et al.	6,199,919 B1	3/2001	Kawasaki et al.
D382,639 S	8/1997	Musgrave et al.	6,199,920 B1	3/2001	Neustadtl
D384,731 S	10/1997	Ramacier, Jr. et al.	6,206,028 B1	3/2001	Holden et al.
5,681,062 A	10/1997	Fukao et al.	6,221,064 B1	4/2001	Nadal
5,682,662 A	11/1997	Coules et al.	6,231,089 B1	5/2001	Decler et al.
5,683,117 A	11/1997	Corbett et al.	D444,054 S	6/2001	Bernard et al.
D387,147 S	12/1997	Vandermast et al.	6,250,688 B1	6/2001	Kirby
5,692,783 A	12/1997	Watanabe et al.	6,257,626 B1	7/2001	Campau
5,695,223 A	12/1997	Boticki	6,260,851 B1	7/2001	Baron
D388,876 S	1/1998	Sampson	6,261,282 B1	7/2001	Jepson et al.
5,709,244 A	1/1998	Patriquin et al.	6,293,596 B1	9/2001	Kinder
5,725,258 A	3/1998	Kujawski	6,296,508 B1	10/2001	Kuwahara et al.
5,737,810 A	4/1998	Krauss	6,296,796 B1	10/2001	Gordon
5,745,957 A	5/1998	Khokhar et al.	6,302,147 B1	10/2001	Rose et al.
5,746,414 A	5/1998	Weldon et al.	6,318,764 B1	11/2001	Trede et al.
5,762,646 A	6/1998	Cotter	6,344,033 B1	2/2002	Jepson et al.
5,784,750 A	7/1998	Sankovic et al.	6,382,593 B1	5/2002	Decler et al.
5,799,987 A	9/1998	Sampson	D459,206 S	6/2002	Caveney et al.
5,820,614 A	10/1998	Erskine et al.	6,402,207 B1	6/2002	Segal
5,837,180 A	11/1998	Linder et al.	6,422,574 B1	7/2002	Mooklar
5,845,943 A	12/1998	Ramacier et al.	6,423,053 B1	7/2002	Lee
5,855,568 A	1/1999	Battiato et al.	6,439,620 B1	8/2002	Guest
5,879,033 A	3/1999	Haensel et al.	6,454,314 B1	9/2002	Grosspietsch et al.
5,882,047 A	3/1999	Ostrander et al.	D465,868 S	11/2002	Gaskins et al.
5,884,531 A	3/1999	Koenig	6,474,698 B2	11/2002	Dobler et al.
D407,803 S	4/1999	Redman	6,481,758 B1	11/2002	Andre et al.
5,897,142 A	4/1999	Kulevsky	6,481,759 B1	11/2002	Kawasaki et al.
5,911,367 A	6/1999	McInerney	6,485,064 B1	11/2002	Davidson
5,911,403 A	6/1999	Decler et al.	6,485,483 B1	11/2002	Fujii
5,911,404 A	6/1999	Cheng	6,497,433 B1	12/2002	Ketcham
5,930,424 A	7/1999	Heimberger et al.	6,505,866 B1	1/2003	Nakamura et al.
5,937,501 A	8/1999	Imgram	6,508,807 B1	1/2003	Peters
5,938,244 A	8/1999	Meyer	6,520,546 B2	2/2003	Szabo
5,941,577 A	8/1999	Musellec	D471,261 S	3/2003	Kozu
5,942,730 A	8/1999	Schwarz et al.	6,540,263 B1	4/2003	Sausner
D413,967 S	9/1999	Yuen	6,543,745 B1	4/2003	Enerson
			6,595,964 B2	7/2003	Finley et al.
			6,609,696 B2	8/2003	Enerson
			6,612,634 B1	9/2003	Zoppas
			6,626,419 B2	9/2003	Decler et al.



(56)

## References Cited

## U.S. PATENT DOCUMENTS

6,626,465 B2	9/2003	Lacroix et al.	7,343,931 B2	3/2008	Packham
D481,125 S	10/2003	Hayamizu	D567,340 S	4/2008	Tiberghien
6,641,177 B1	11/2003	Pinciario	7,352,771 B2	4/2008	Garber
6,649,829 B2	11/2003	Garber et al.	D569,507 S	5/2008	Blanchard
6,652,007 B1	11/2003	Hwang	D569,955 S	5/2008	Chen
D484,241 S	12/2003	Peters et al.	7,377,553 B2	5/2008	Takayanagi
6,669,681 B2	12/2003	Jepson et al.	D570,457 S	6/2008	Brown
6,676,172 B2	1/2004	Alksnis	7,390,029 B2	6/2008	Matsubara
6,682,547 B2	1/2004	McEwen et al.	7,393,019 B2	7/2008	Taga et al.
D486,909 S	2/2004	Cise et al.	7,394,375 B2	7/2008	Johnson
6,688,654 B2	2/2004	Romero	7,401,820 B2	7/2008	Niki
6,692,038 B2	2/2004	Braun	7,434,842 B2	10/2008	Schmidt
6,695,817 B1	2/2004	Fangrow, Jr.	7,434,846 B2	10/2008	Baumgartner
6,705,591 B2	3/2004	Decler	7,448,653 B2	11/2008	Jensen et al.
D488,866 S	4/2004	O'Dell	D584,008 S	12/2008	Juhlin
6,722,705 B2	4/2004	Korkor	7,464,970 B2	12/2008	Yamada et al.
6,722,708 B2	4/2004	Morohoshi et al.	7,467,813 B2	12/2008	Gunderson
6,762,365 B2	7/2004	Inoue et al.	7,469,472 B2	12/2008	Decler et al.
6,767,017 B2	7/2004	Crapart et al.	7,478,840 B2	1/2009	Yousseffifar
D495,050 S	8/2004	Guala	7,488,446 B2	2/2009	Meyer et al.
6,783,520 B1	8/2004	Candray et al.	7,494,156 B2	2/2009	Okada
D497,428 S	10/2004	Hayamizu	7,503,595 B2	3/2009	McKay
6,799,747 B1	10/2004	Lai	7,516,990 B2	4/2009	Jamison et al.
D498,533 S	11/2004	Hayamizu	7,546,857 B2	6/2009	Chadbourne et al.
6,814,726 B1	11/2004	Lauer	7,547,047 B2	6/2009	Decler et al.
6,840,277 B1	1/2005	Nimberger	D595,845 S	7/2009	Mros et al.
6,846,021 B2	1/2005	Rohde et al.	D595,846 S	7/2009	Racz et al.
6,848,602 B2	2/2005	Decler et al.	D596,288 S	7/2009	Racz et al.
6,848,723 B2	2/2005	Lamich	D596,739 S	7/2009	Ng et al.
6,863,314 B2	3/2005	Guest	7,562,906 B2	7/2009	Schmidt
6,871,669 B2	3/2005	Meyer et al.	7,566,077 B2	7/2009	Tsurumi
6,871,878 B2	3/2005	Miros	D601,248 S	9/2009	Mros et al.
D503,778 S	4/2005	Wicks	7,581,763 B2	9/2009	Salomon-Bahls
6,886,803 B2	5/2005	Mikiya et al.	D602,128 S	10/2009	Williams et al.
6,897,374 B2	5/2005	Garber et al.	7,614,666 B2	11/2009	Eggert et al.
6,899,315 B2	5/2005	Maiville et al.	7,631,660 B2	12/2009	Decler et al.
6,902,144 B2	6/2005	Decler	7,647,954 B2	1/2010	Garber et al.
D507,647 S	7/2005	Beck et al.	7,666,178 B2	2/2010	McMichael
6,916,007 B2	7/2005	Decler et al.	D612,019 S	3/2010	Williams et al.
6,916,050 B2	7/2005	Milhas	D612,021 S	3/2010	Schmidt
6,926,311 B2	8/2005	Chang et al.	7,677,608 B2	3/2010	Takayanagi
6,929,246 B2	8/2005	Arzenton et al.	D613,853 S	4/2010	Ng et al.
6,945,273 B2	9/2005	Reid	7,695,020 B2	4/2010	Schmidt
6,949,084 B2	9/2005	Marggi et al.	7,708,025 B2	5/2010	Johnson
6,962,275 B2	11/2005	Decler et al.	7,731,244 B2	6/2010	Miros et al.
6,978,800 B2	12/2005	Decler et al.	D619,706 S	7/2010	Schon et al.
6,981,547 B2	1/2006	Maguire et al.	7,753,415 B2	7/2010	Tiberghien et al.
6,997,486 B2	2/2006	Milhas	7,770,939 B2	8/2010	Jensen et al.
6,997,919 B2	2/2006	Olsen et al.	7,802,822 B2	9/2010	Poder et al.
7,005,581 B2	2/2006	Burnette	7,806,139 B2	10/2010	Packham et al.
7,011,342 B2	3/2006	Guivarc et al.	7,841,357 B2	11/2010	Rankin
7,014,214 B2	3/2006	Kaneko	D629,894 S	12/2010	Lombardi et al.
D522,109 S	5/2006	White et al.	7,849,877 B2	12/2010	Tan et al.
7,040,670 B2	5/2006	Madden	7,857,359 B2	12/2010	Zeitlinger et al.
7,044,161 B2	5/2006	Tiberghien	D630,320 S	1/2011	Lombardi et al.
7,044,506 B2	5/2006	Dong	D632,783 S	2/2011	Maesarapu
D523,553 S	6/2006	Beck et al.	7,878,553 B2	2/2011	Wicks et al.
7,080,665 B2	7/2006	Whall	D634,840 S	3/2011	Lombardi et al.
7,081,223 B2	7/2006	Khoury	D639,398 S	6/2011	Wilhelm
7,108,297 B2	9/2006	Takayanagi et al.	7,954,374 B2	6/2011	Rankin
7,118,138 B1	10/2006	Rowley et al.	7,954,515 B2	6/2011	Gerst
7,128,348 B2	10/2006	Kawamura et al.	D642,244 S	7/2011	Wilhelm
7,137,654 B2	11/2006	Segal et al.	7,976,071 B2	7/2011	Bibby
7,140,592 B2	11/2006	Phillips	D645,547 S	9/2011	Lombardi et al.
7,147,252 B2	12/2006	Teuscher et al.	D649,240 S	11/2011	Lewis et al.
7,150,478 B2	12/2006	Poirier et al.	D650,478 S	12/2011	Lewis
7,153,296 B2	12/2006	Mitchell	D652,510 S	1/2012	Lombardi et al.
7,163,022 B2	1/2007	Whall	D652,511 S	1/2012	Lombardi et al.
D540,944 S	4/2007	Guala	D654,573 S	2/2012	Lombardi et al.
7,210,917 B2	5/2007	Lai et al.	8,113,546 B2	2/2012	Jensen et al.
D547,446 S	7/2007	Racz et al.	D655,393 S	3/2012	Whitaker
D550,355 S	9/2007	Racz et al.	D659,393 S	5/2012	Hermann
D557,409 S	12/2007	Veliss et al.	D663,022 S	7/2012	Lombardi et al.
7,316,428 B2	1/2008	Takayanagi et al.	8,235,426 B2	8/2012	Pisula et al.
D564,660 S	3/2008	Hayashi	8,397,756 B2	3/2013	Packham et al.
			8,397,758 B2	3/2013	Hillesheim et al.
			D699,840 S	2/2014	Lombardi et al.
			D701,304 S	3/2014	Lair et al.
			8,678,446 B2	3/2014	Nakamura



(56)

## References Cited

## U.S. PATENT DOCUMENTS

D707,355 S 6/2014 Bow  
 D709,612 S 7/2014 Lewis  
 D725,421 S 3/2015 Lee  
 D727,982 S 4/2015 Renski et al.  
 D728,780 S 5/2015 Pieroni et al.  
 9,157,560 B2 10/2015 Rehder et al.  
 D749,723 S 2/2016 Chauvette  
 D756,512 S 5/2016 Oberlaender et al.  
 9,388,929 B2 7/2016 Lewis et al.  
 9,464,741 B2 10/2016 Lewis et al.  
 D771,806 S 11/2016 Steele  
 D773,043 S 11/2016 Ingram et al.  
 D773,658 S 12/2016 Bow  
 D773,659 S 12/2016 Cain et al.  
 D783,815 S 4/2017 Lewis et al.  
 D785,790 S 5/2017 Lewis et al.  
 D791,724 S 7/2017 Becker  
 9,695,966 B2 7/2017 Lombardi et al.  
 10,001,236 B2 6/2018 Lewis et al.  
 10,156,307 B2 12/2018 Lewis et al.  
 D838,366 S 1/2019 Lewis  
 2001/0017466 A1 8/2001 Braun  
 2002/0022762 A1 2/2002 Beane et al.  
 2002/0036406 A1 3/2002 Parker  
 2002/0070547 A1 6/2002 Guertin  
 2002/0093192 A1 7/2002 Matkovich  
 2002/0140172 A1 10/2002 Platusich  
 2002/0156344 A1 10/2002 Pasricha et al.  
 2002/0185861 A1 12/2002 Inoue et al.  
 2003/0004397 A1 1/2003 Kameya et al.  
 2003/0067162 A1 4/2003 Welsh et al.  
 2003/0193188 A1 10/2003 Miros  
 2003/0230894 A1 12/2003 Cleveland et al.  
 2004/0021318 A1 2/2004 Fritze et al.  
 2004/0056484 A1 3/2004 Kwon et al.  
 2004/0094903 A1 5/2004 Sutherland  
 2004/0183300 A1 9/2004 Iwasaki et al.  
 2004/0195830 A1 10/2004 Gilmour  
 2004/0199143 A1 10/2004 Lauer  
 2004/0227346 A1 11/2004 Jamison et al.  
 2004/0232696 A1 11/2004 Andre  
 2005/0033237 A1 2/2005 Fentress et al.  
 2005/0046184 A1 3/2005 Chang et al.  
 2005/0056121 A1 3/2005 Lyman  
 2005/0057042 A1 3/2005 Wicks  
 2005/0082828 A1 4/2005 Wicks et al.  
 2005/0087981 A1 4/2005 Yamada et al.  
 2005/0197000 A1 9/2005 Tiberghien et al.  
 2005/0209583 A1 9/2005 Powers et al.  
 2005/0217265 A1 10/2005 Popp et al.  
 2005/0242579 A1 11/2005 Bright et al.  
 2005/0275220 A1 12/2005 Shu  
 2006/0066100 A1 3/2006 Nakashima et al.  
 2006/0118066 A1 6/2006 Martins  
 2006/0128180 A1 6/2006 Gammons  
 2006/0135666 A1 6/2006 Bueno et al.  
 2006/0152003 A1 7/2006 Slunick et al.  
 2006/0202146 A1 9/2006 Doyle  
 2006/0264814 A1 11/2006 Sage  
 2006/0293629 A1 12/2006 Cote et al.  
 2007/0025811 A1 2/2007 Wilhelm  
 2007/0029795 A1 2/2007 Moner et al.  
 2007/0029796 A1 2/2007 Bibby  
 2007/0106213 A1 5/2007 Spera et al.  
 2007/0137718 A1 6/2007 Rushlander et al.  
 2007/0169825 A1 7/2007 Packham et al.  
 2007/0209716 A1 9/2007 Rankin  
 2007/0251376 A1 11/2007 Toulouse et al.  
 2007/0284875 A1 12/2007 Salomon-Bahls et al.  
 2008/0007051 A1 1/2008 Jensen et al.  
 2008/0011703 A1 1/2008 Schmeisser et al.  
 2008/0012314 A1 1/2008 Harger et al.  
 2008/0018105 A1 1/2008 Le Bars  
 2008/0048442 A1 2/2008 Kerin et al.  
 2008/0048448 A1 2/2008 Jamison et al.

2008/0078464 A1 4/2008 Loewe  
 2008/0111371 A1 5/2008 Feger et al.  
 2008/0111372 A1 5/2008 Trede et al.  
 2008/0129047 A1 6/2008 Blivet et al.  
 2008/0164694 A1 7/2008 Zdroik et al.  
 2008/0191466 A1 8/2008 Knipple et al.  
 2008/0200901 A1 8/2008 Rasmussen et al.  
 2008/0277923 A1 11/2008 Brandt et al.  
 2008/0277924 A1 11/2008 Jensen et al.  
 2008/0284167 A1 11/2008 Lim et al.  
 2008/0287920 A1 11/2008 Fangrow et al.  
 2009/0079187 A1 3/2009 Malone  
 2009/0127847 A1 5/2009 Hagen et al.  
 2009/0129047 A1 5/2009 Park et al.  
 2009/0140519 A1 6/2009 Pavnaskar et al.  
 2009/0167018 A1 7/2009 Lien  
 2009/0187166 A1 7/2009 Young  
 2009/0188575 A1 7/2009 Williams et al.  
 2009/0256355 A1 10/2009 Wicks et al.  
 2009/0261582 A1 10/2009 Gaudin  
 2010/0001516 A1 1/2010 Pisula et al.  
 2010/0019487 A1 1/2010 Decler et al.  
 2010/0056975 A1 3/2010 Dale et al.  
 2010/0078934 A1 4/2010 Matsunaga  
 2010/0127492 A1 5/2010 Poder et al.  
 2010/0185040 A1 7/2010 Uber et al.  
 2010/0194100 A1 8/2010 Koch  
 2010/0276922 A1 11/2010 Rehder et al.  
 2010/0295295 A1 11/2010 Schmidt  
 2010/0301599 A1 12/2010 Jensen et al.  
 2010/0319796 A1 12/2010 Whitaker  
 2011/0012340 A1 1/2011 Packham et al.  
 2011/0127767 A1 6/2011 Wicks et al.  
 2011/0204621 A1 8/2011 Whitaker et al.  
 2011/0204622 A1 8/2011 Lewis et al.  
 2011/0210541 A1 9/2011 Lewis et al.  
 2012/0031515 A1 2/2012 Whitaker  
 2012/0068457 A1 3/2012 Pisula et al.  
 2012/0299290 A1 11/2012 Pisula et al.  
 2012/0299296 A1 11/2012 Lombardi, III  
 2016/0102791 A1 4/2016 Johnson et al.  
 2017/0036007 A1 2/2017 Hallisey et al.  
 2019/0117951 A1 4/2019 Fujieda et al.

## FOREIGN PATENT DOCUMENTS

CN 1644974 A 7/2005  
 CN 101311603 A 11/2008  
 CN 201170406 Y 12/2008  
 DE 1868896 U 3/1963  
 DE 3439522 A1 8/1985  
 DE 3533000 A1 3/1987  
 DE 4122455 A1 1/1993  
 DE 4138064 C1 5/1993  
 DE 19800050 A1 7/1998  
 DE 102005015343 A1 10/2006  
 EP 0267067 A1 5/1988  
 EP 0360634 A1 3/1990  
 EP 0390746 A2 10/1990  
 EP 0482277 A1 4/1992  
 EP 0592823 A1 4/1994  
 EP 0715111 A1 6/1996  
 EP 0865779 A1 9/1998  
 EP 0877891 A1 11/1998  
 EP 0890054 A1 1/1999  
 EP 0982525 A1 3/2000  
 EP 1497582 A1 1/2005  
 EP 1564469 A1 8/2005  
 EP 1843074 A1 10/2007  
 EP 2848280 A1 3/2015  
 FR 2031965 A5 11/1970  
 FR 2429370 A1 1/1980  
 FR 2808071 A1 10/2001  
 FR 2853043 A1 10/2004  
 FR 2870921 A1 12/2005  
 FR 2903164 A1 1/2008  
 FR 2919372 A1 1/2009  
 GB 0583459 A 12/1946  
 GB 0890775 A 3/1962



(56)

## References Cited

## FOREIGN PATENT DOCUMENTS

GB	2177769	A	1/1987
GB	2218166	A	11/1989
GB	2271157	A	4/1994
GB	2379253	A	3/2003
JP	53-006918	A	1/1978
JP	57-145734	A	9/1982
JP	05-223189	A	8/1993
JP	07-145889	A	6/1995
JP	10-169869	A	6/1998
JP	11-030373	A	2/1999
JP	11-082849	A	3/1999
JP	2003-042363	A	2/2003
JP	2003-042368	A	2/2003
JP	2005-140164	A	6/2005
JP	2006-512540	A	4/2006
JP	2009-180336	A	8/2009
JP	2010-509553	A	3/2010
JP	5223189	B2	6/2013
WO	93/17270	A1	9/1993
WO	95/08732	A1	3/1995
WO	98/23891	A1	6/1998
WO	98/23892	A1	6/1998
WO	00/79172	A1	12/2000
WO	2003/091616	A1	11/2003
WO	2004/027269	A2	4/2004
WO	2004/104466	A1	12/2004
WO	2005/064216	A2	7/2005
WO	2006/031958	A1	3/2006
WO	2006/073778	A1	7/2006
WO	2006/084171	A2	8/2006
WO	2006/135666	A2	12/2006
WO	2007/038222	A2	4/2007
WO	2007/116387	A2	10/2007
WO	2007/120620	A2	10/2007
WO	2008/023021	A1	2/2008
WO	2009/026441	A1	2/2009
WO	2011/079226	A1	6/2011
WO	2018/200914	A1	11/2018

## OTHER PUBLICATIONS

U.S. Appl. filed Sep. 29, 2010, Packham et al., Published., U.S. Appl. No. 12/893,432.

U.S. Appl. filed Nov. 30, 2010, Lombardi et al., Pending, copy attached., U.S. Appl. No. 29/380,098.

U.S. Appl. filed Jan. 28, 2011, Wicks et al., Pending, copy attached., U.S. Appl. No. 13/016,636.

U.S. Appl. filed Feb. 11, 2011, Lombardi et al., Pending, copy attached., U.S. Appl. No. 29/385,363.

U.S. Appl. filed Feb. 11, 2011, Lombardi et al., Pending, copy attached., U.S. Appl. No. 29/385,360.

U.S. Appl. filed Feb. 11, 2011, Lombardi et al., Pending, copy attached., U.S. Appl. No. 29/385,357.

U.S. Appl. filed Dec. 23, 2010, Williams et al., Pending, copy attached., U.S. Appl. No. 12/818,973.

U.S. Appl. filed Dec. 23, 2010, Lewis et al., Pending, copy attached., U.S. Appl. No. 12/976,943.

U.S. Appl. filed Dec. 23, 2010, Lewis et al., Pending, copy attached., U.S. Appl. No. 12/976,894.

U.S. Appl. filed Dec. 22, 2010, Cairns et al., Pending, copy attached., U.S. Appl. No. 12/976,921.

U.S. Appl. filed Aug. 9, 2010, Jensen et al., Published., U.S. Appl. No. 12/853,063.

Stainless Steel Overview: History [online], Stainless Steel Industry of North America, retrieved on Apr. 9, 2010, retrieved from the Internet: <URL: <http://www.ssina.com/overview/history.html>>, 1 page.

Stackable Hose Barb Elbow—1/2" CTS x 1/2 ID Barb, <http://www.freshwatersystems.com/p-1714-stackable-hose-barb-elbow-12-cts-x-12-id-barb.aspx?affiliated=10052&utm.sub.-source=shopzilla>

&utm.sub.-m-edium=Feed&utm.sub.-campaign=Product&utm.sub.-term=3512-1008, date accessed Sep. 14, 2009, 1 page.

Stackable Hose Barb Elbow—1/2" CTS x 1/2 ID Barb, <http://www.freshwatersystems.com/p-1714-stackable-hose-barb-elbow-12-cts-x-12-id-barb.aspx?affiliated=10052&utm.sub.-source=shopzilla&utm.sub.-m-edium=Feed&utm.sub.-campaign=Product&utm.sub.-term=3512-1008>, date accessed Sep. 14, 2009, 1 page.

Stackable Hose Barb Elbow—1/2" CTS x 1/2 ID Barb, [http://www.freshwatersystems.com/p-1714-stackable-hose-barb-elbow-12-cts-x-12-id-barb.aspx?affiliated=10052&utm\\_source=shopzilla&utm\\_medium=Feed&utm\\_campaign=Product&utm\\_term=3512-1008](http://www.freshwatersystems.com/p-1714-stackable-hose-barb-elbow-12-cts-x-12-id-barb.aspx?affiliated=10052&utm_source=shopzilla&utm_medium=Feed&utm_campaign=Product&utm_term=3512-1008), date accessed Sep. 14, 2009, 1 page.

Singapore Office Action dated Oct. 16, 2014, Application No. 2014/350822389P, 11 pages.

Science of Hose Barbs, Colder Products Company, <http://www.pddnet.com/articlethe-science-of-hose-barbs/>, date accessed Sep. 4, 2009, 6 page.

Science of Hose Barbs, Colder Products Company, <http://www.pddnet.com/articlethe-science-of-hose-barbs/>, date accessed Sep. 4, 2009, 6 page.

Nylon, Polypropylene Kynar (PVDF) Plastic Fittings for Flexible Tubing & Hose, <http://www.omega.com/pdf/tubing/fittings.sub.--tubing.sub.-hose/ny-lon.sub.-poly.sub.-kynar/nylon.asp>; date accessed Sep. 14, 2009, 2 pages.

Mills, The Process of Vacuum-forming Plastic Parts, IPFrontline.com [online], retrieved on Apr. 9, 2010, retrieved from the Internet: <URL: <http://www.ipfrontline.com/depts/article.asp?id=453&deptid=2>>, 3 pages.

Mills, The Process of Vacuum-forming Plastic Parts, IPFrontline.com [online], retrieved on Apr. 9, 2010, retrieved from the Internet: <URL: <http://www.ipfrontline.com/depls/article.asp?id=453&deplid=2>>, 3 pages.

Japanese Patent Office, "Decision of Refusal dated Jul. 15, 2015", Japanese Patent Application No. 2012-546210, 6 pages.

Japanese Application No. 2012-546210: Office Action dated Aug. 25, 2016, 2 pages.

Japanese Application No. 2012-54621: Office Action dated Jul. 9, 2014, 13 pages.

International Search Report and Written Opinion dated May 23, 2011, PCT/US2010/061896, 11 pages.

International Search Report and Written Opinion dated Apr. 7, 2011, PCT/US2010/061903, 11 pages.

International Patent Application No. PCT/US2017/058663; Int'l Search Report and the Written Opinion; dated Mar. 29, 2018; 18 pages.

Intellectual Property Office of Singapore, Invitation to Respond to Written Opinion and Written Opinion, Singapore Patent Application No. 201204718-9, 6 pages.

High-Flow Quick Disconnect Couplings; <http://www.coleparmer.com/catalog/product.sub.-view.asp?sku=3130355>; date accessed Sep. 14, 2009, 3 pages.

High-Flow Quick Disconnect Couplings; <http://www.coleparmer.com/catalog/product.sub.-view.asp?sku=3130355>; date accessed Sep. 14, 2009, 3 pages.

Flojet "Quick Connect" Port System Adapter 90 Elbow Type Quad Port X 1/2" Hose Barb, <http://www.amazon.com/Quick-Connect-Port-System-Quad-Barb-90/dp/B0000AZ77-1/ref=sr.sub.--1.sub.-16?s=sporting-goods&ie=UTF8&qid=1300220596&sr=1-16>, date accessed Sep. 14, 2009; 3 pages.

Flojel "Quick Connect" Port System Adapter 90 Elbow Type Quad Port X 1/2" Hose Barb, <http://www.amazon.com/Quick-Connect-Port-System-Quad-Barb-90/dp/B0000AZ77-1/ref=sr.sub.--1.sub.-16?s=sporting-goods&ie=UTF8&qid=1300220596&sr=1-16>, date accessed Sep. 14, 2009; 3 pages.

EP Search Report dated Jul. 25, 2014 for Application No. 10803324.2-1662, 5 pages.

Chinese State Intellectual Property Office (SIPO); Office Action dated May 14, 2015; Chinese Patent Application No. 201080063938.8; 11 pages.

Capabilities [online], Jay Manufacturing Corp., retrieved on Apr. 9, 2010, retrieved from the Internet: <URL: <http://www.jaymfg.com/capabilities.htm>>, 2 pages.

(56)

**References Cited**

OTHER PUBLICATIONS

Capabilities [online], Jay Manufacturing Corp., retrieved on Apr. 9, 2010, retrieved from the Internet: <URL: <http://www.jaymfg.com/capabilities.htm>>, 2 pages.

Brochure, "Precision Components", Value Plastics, Inc., 2002.

Barbed Tee Adapter, 1/2 in to 3/8 in to 1/2 in [Item # F1728], <http://www.horticulturesource.com/product.sub--info.php/products.sub-i-d/4016/language/en>; dated accessed Sep. 14, 2009, 3 pages.

About Us [online], Thuro Metal Products [retrieved on Apr. 9, 2010], retrieved from the Internet: <URL: <http://www.thurometal.com/about.html>>, 2 pages.

About Us [online], Thuro Metal Products [retrieved on Apr. 9, 2010], retrieved from the Internet: <URL: <http://www.thurometal.com/about.html>>, 2 pages.

English Translation of CN Office Action dated Apr. 29, 2019 for CN Application No. 201611020248.

IPEA/409—International Preliminary Report on Patentability dated May 9, 2019 for WO Application No. PCT/US17/058663.



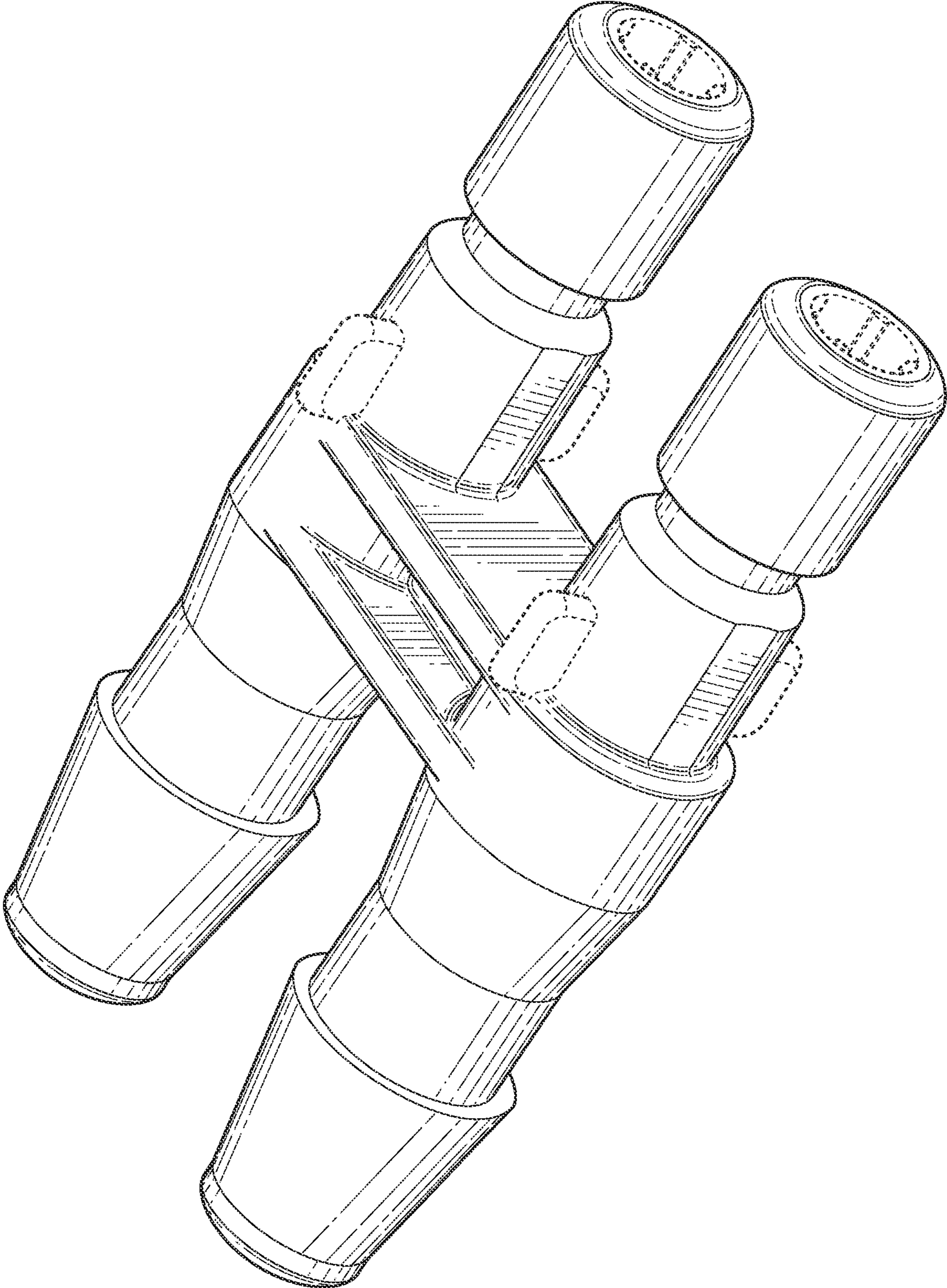

FIG. 1



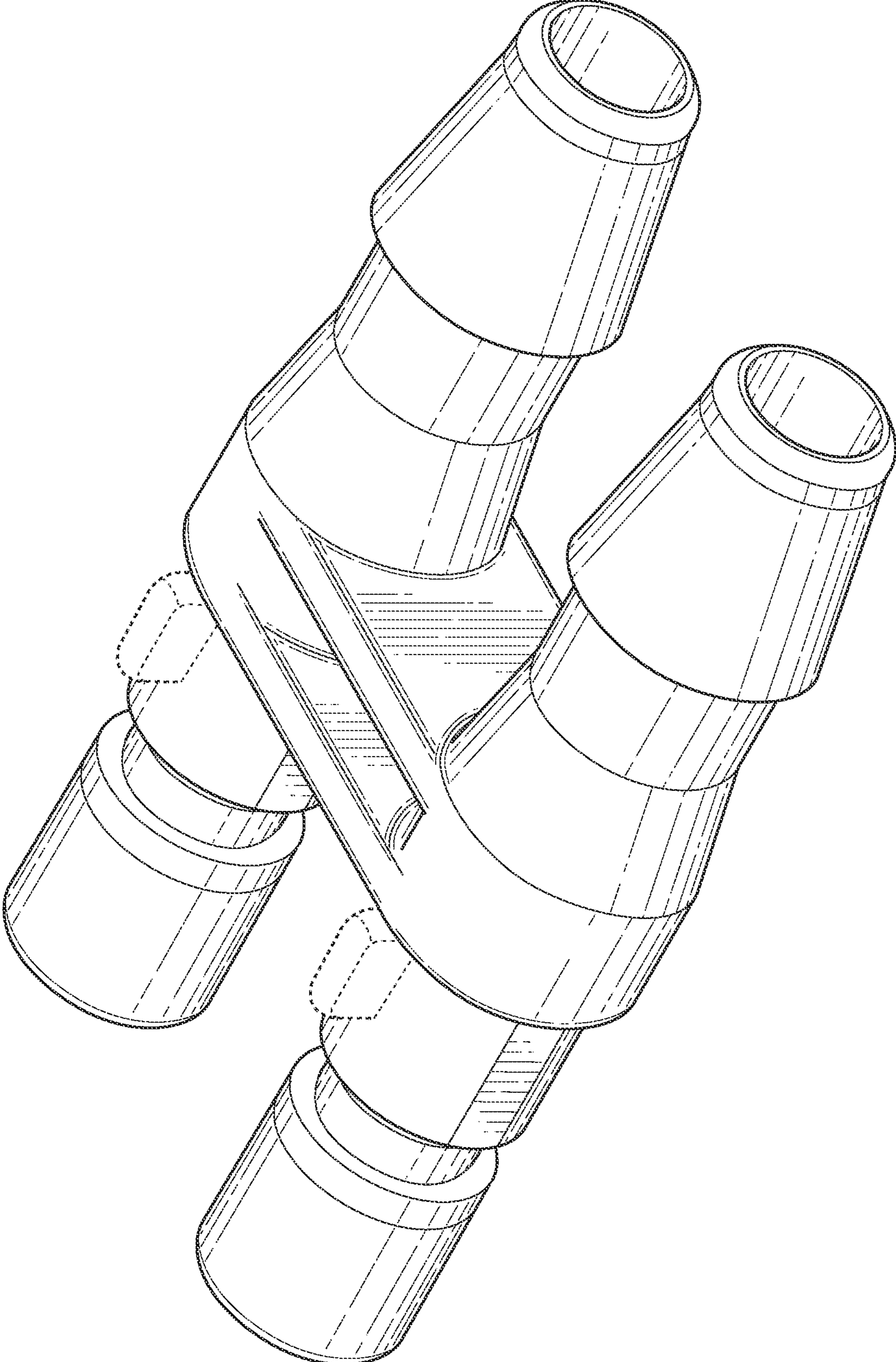

FIG. 2



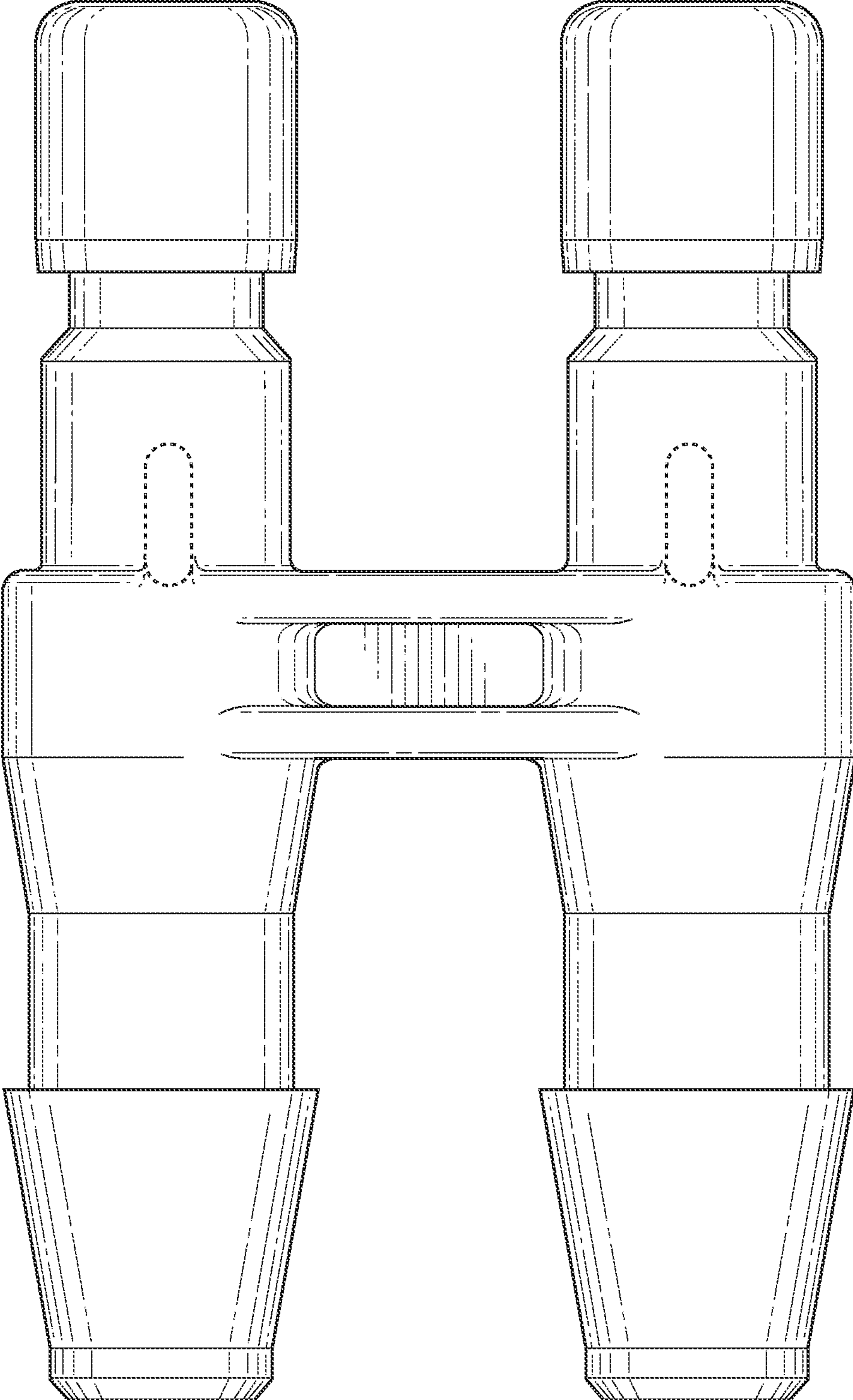

FIG. 3



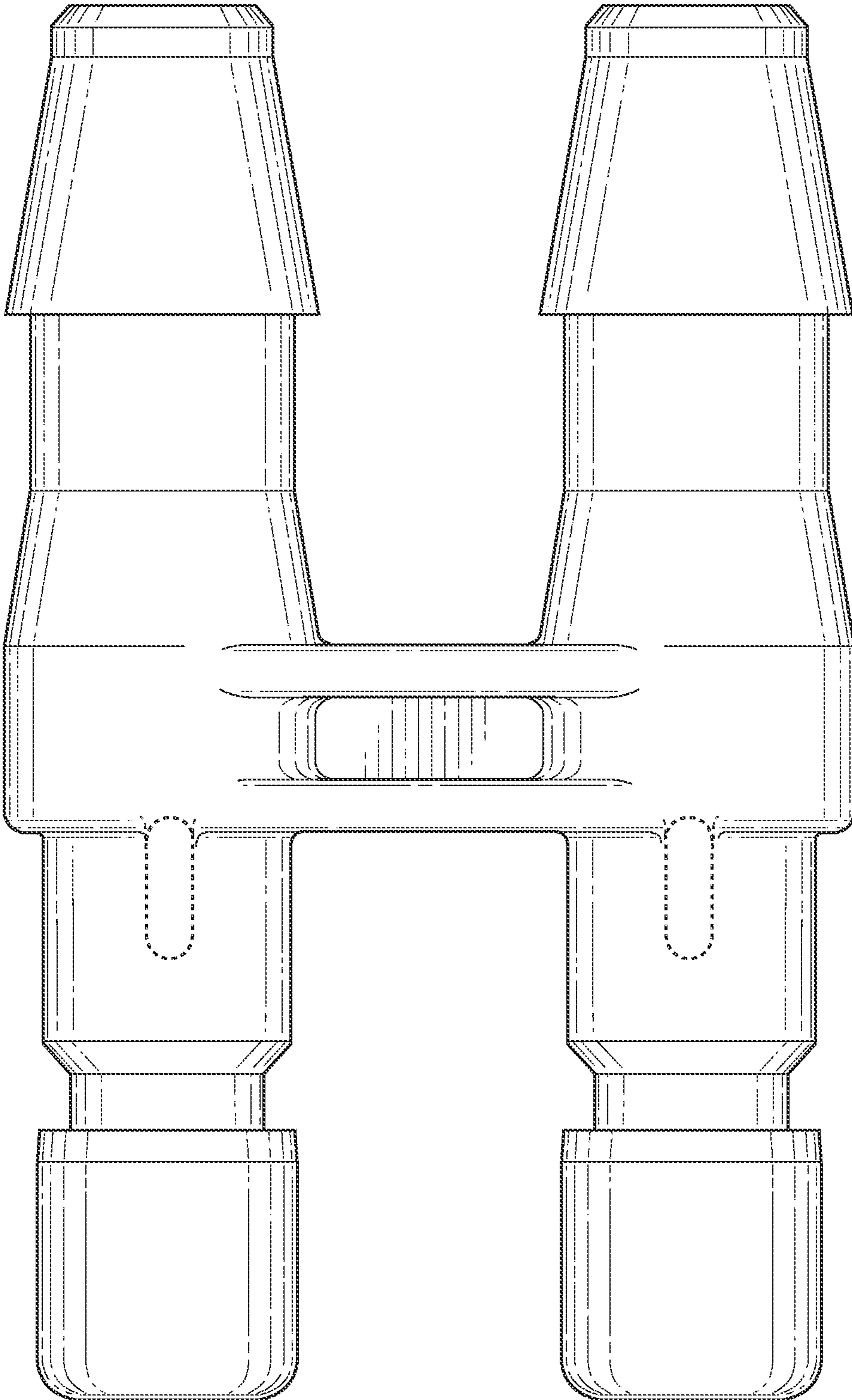

FIG. 4

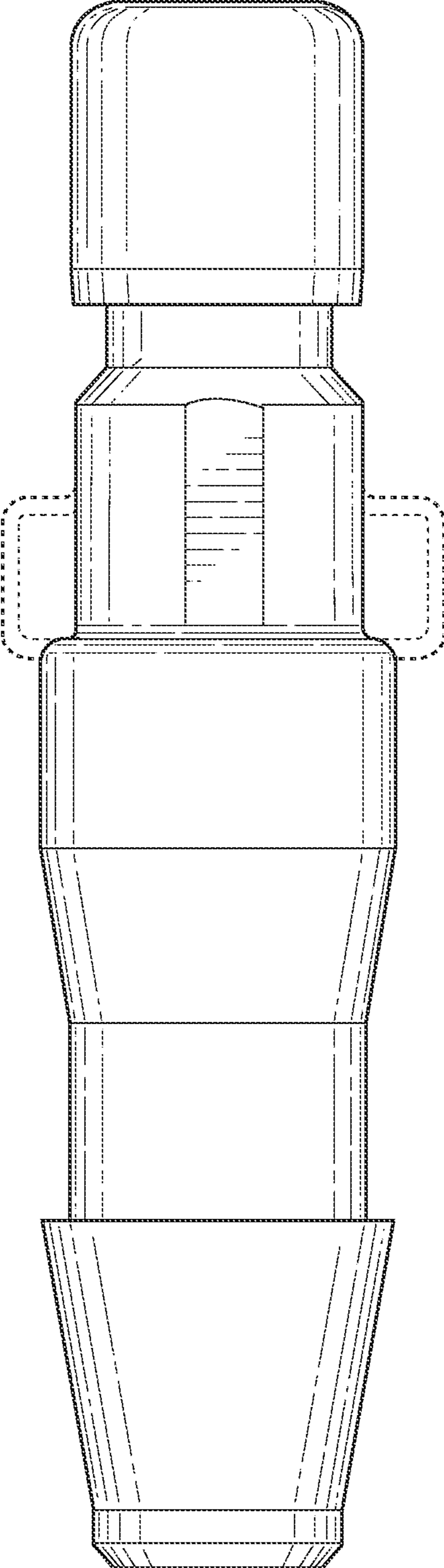

FIG. 5



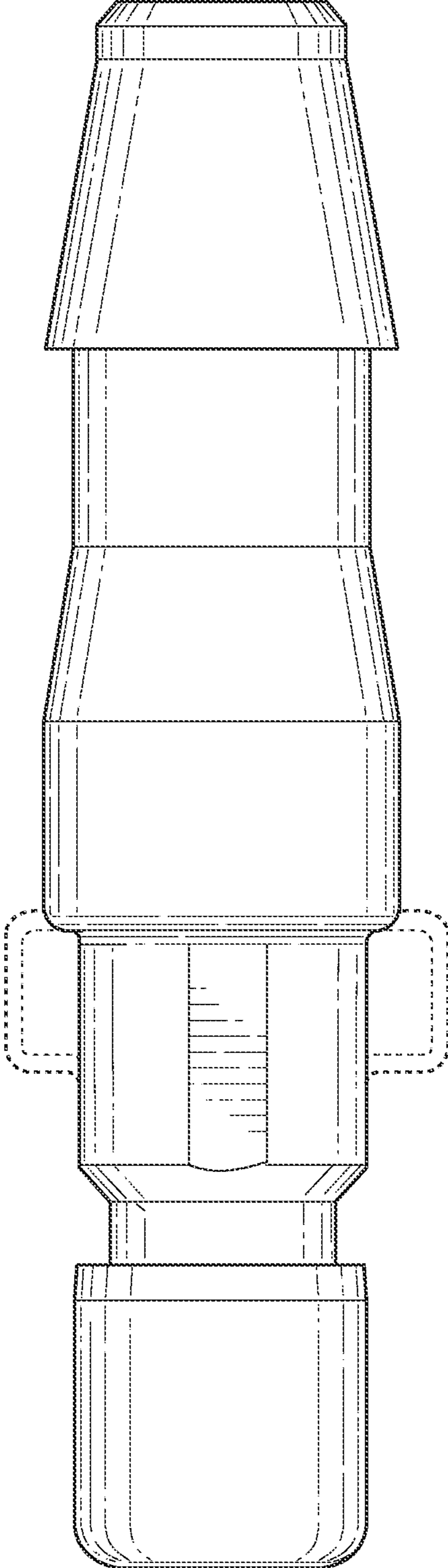

FIG. 6

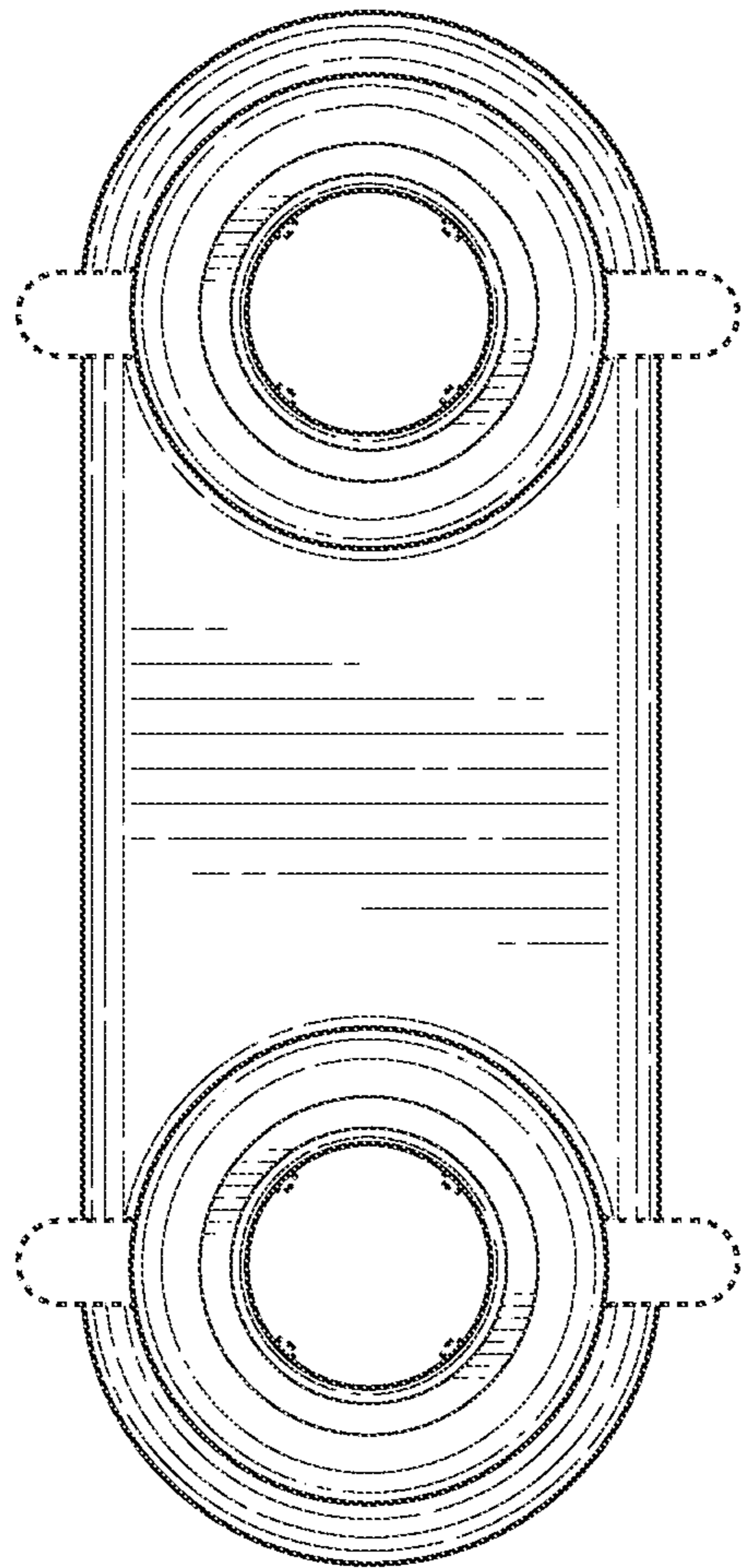

FIG. 7



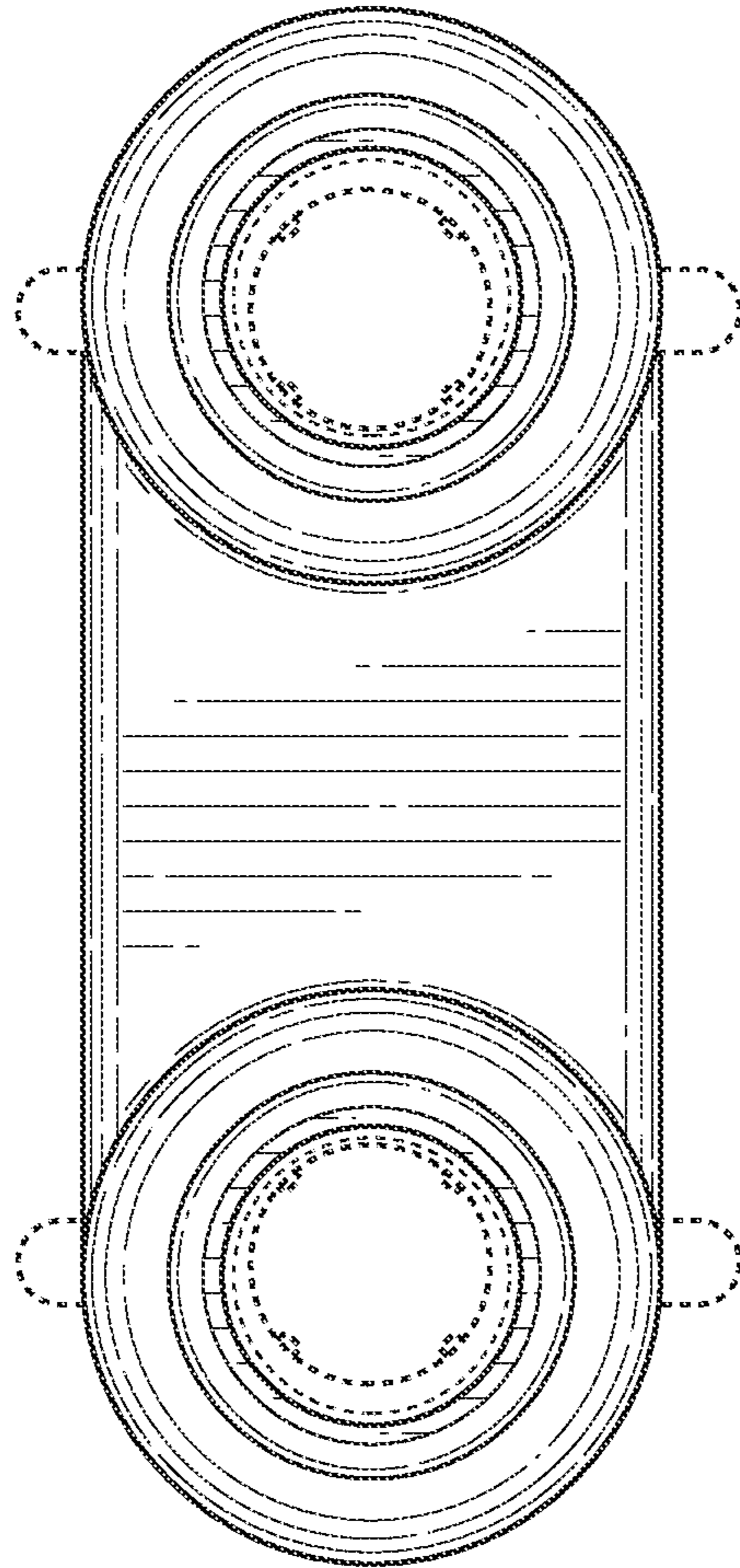

FIG. 8