



US00D964191S

(12) **United States Design Patent** (10) **Patent No.:** **US D964,191 S**
Aramaki et al. (45) **Date of Patent:** **** Sep. 20, 2022**

(54) **CAPACITIVE SENSOR**
(71) Applicant: **Mitsubishi Electric Corporation**,
Tokyo (JP)
(72) Inventors: **Toru Aramaki**, Tokyo (JP); **Tomokazu Ogomi**, Tokyo (JP); **Hideki Matsui**, Tokyo (JP); **Hiroshi Koike**, Tokyo (JP)
(73) Assignee: **Mitsubishi Electric Corporation**,
Tokyo (JP)
(**) Term: **15 Years**
(21) Appl. No.: **29/677,446**
(22) Filed: **Jan. 21, 2019**
(30) **Foreign Application Priority Data**
Aug. 21, 2018 (JP) 2018-018130
(51) **LOC (13) Cl.** **10-04**
(52) **U.S. Cl.**
USPC **D10/70**
CPC **G06F 3/16** (2013.01)
(58) **Field of Classification Search**
USPC D10/65, 70, 75, 81, 46; D13/133,
D13/153-156, 184, 199; D14/433, 434,
D14/484.1; 73/514, 335, 34 C; 324/688,
324/662, 689, 690, 687, 686
CPC . G06F 3/16; G08B 3/00; H04M 11/00; H04N
7/14; H04N 7/26
See application file for complete search history.

(56) **References Cited**
U.S. PATENT DOCUMENTS
D225,333 S * 12/1972 Adams D13/163
D261,738 S * 11/1981 Shumway D10/79
4,439,647 A * 3/1984 Calandrello H01H 13/702
200/86 R
4,929,426 A * 5/1990 Bodai G01N 33/4925
422/403

5,231,380 A * 7/1993 Logan G06F 3/0213
361/679.18
D344,030 S * 2/1994 Kerschner D10/80
5,448,511 A * 9/1995 Paurus H01L 25/0657
361/749
6,400,162 B1 * 6/2002 Mallory G01B 7/003
324/688
6,724,366 B2 * 4/2004 Crawford G06F 3/03549
345/157
D704,578 S * 5/2014 Chen D10/70
8,824,136 B1 * 9/2014 Interian, III G05G 9/08
D14/251
D753,108 S * 4/2016 Kuwabara D14/344
10,013,058 B2 * 7/2018 Puskarich H01L 41/0986
10,120,446 B2 * 11/2018 Pance G06F 3/041
10,684,728 B2 * 6/2020 Wingate G06F 3/044
(Continued)

Primary Examiner — Richard E Chilcot
(74) *Attorney, Agent, or Firm* — Studebaker & Brackett
PC

(57) **CLAIM**
The ornamental design for a capacitive sensor, as shown and described.

DESCRIPTION
FIG. 1 is a perspective view of the front, right, and top sides of a capacitive sensor showing our new design;
FIG. 2 is a front view thereof;
FIG. 3 is a rear view thereof;
FIG. 4 is a right side view thereof, a left side view being a mirror image thereof;
FIG. 5 is a top plan view thereof;
FIG. 6 is a bottom plan view thereof; and,
FIG. 7 is an enlarged view of a part 7-7.
The broken lines shown represent unclaimed subject matter of the capacitive sensor and form no part of the claimed design.
The dash-dot lines represent the boundary between the claimed design and unclaimed design and form no part of the claimed design.

1 Claim, 7 Drawing Sheets

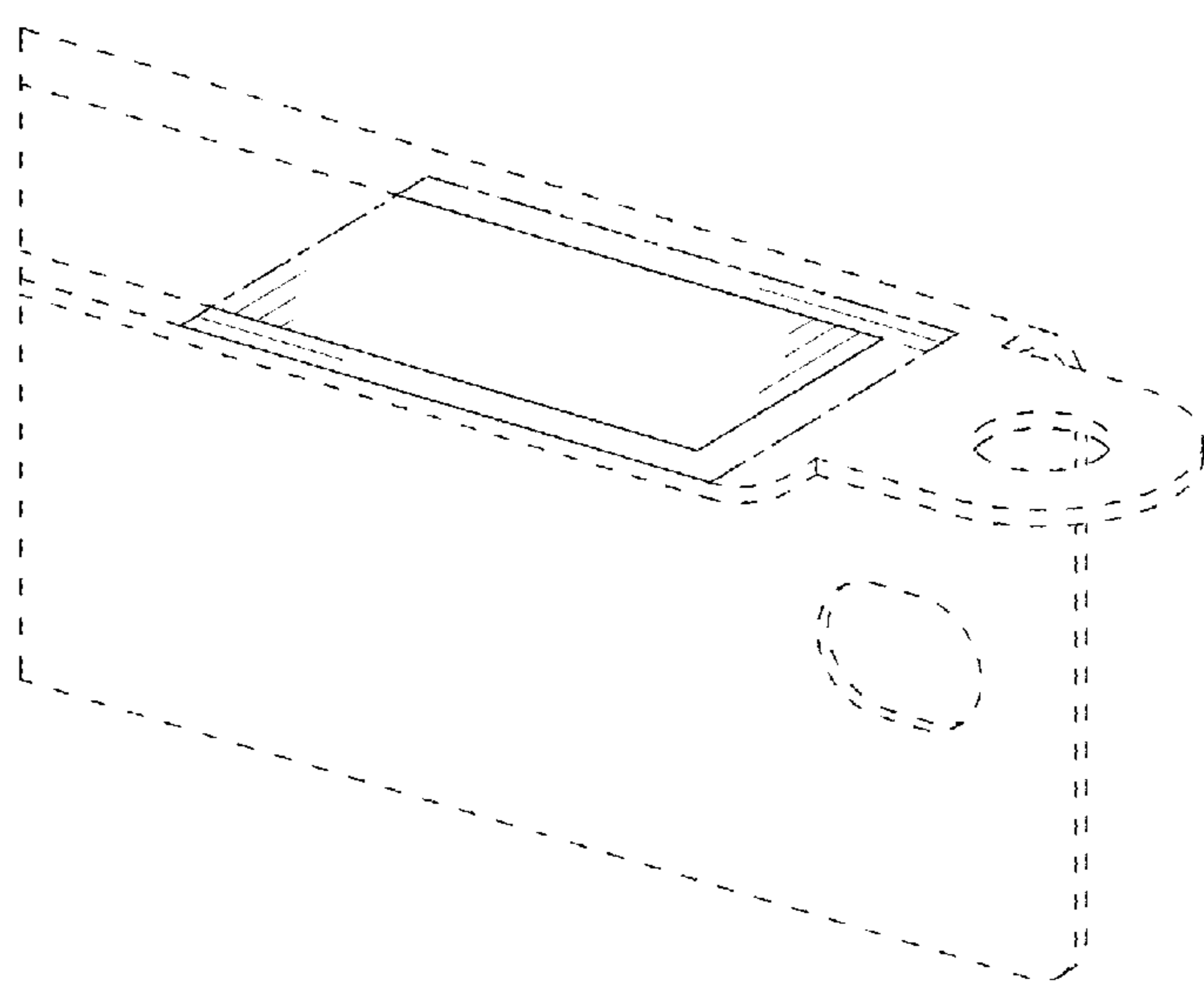

(56)

References Cited

U.S. PATENT DOCUMENTS

D949,030 S * 4/2022 Timmerman D10/70
2019/0056759 A1 * 2/2019 Wang G06F 3/038

* cited by examiner

Fig.1

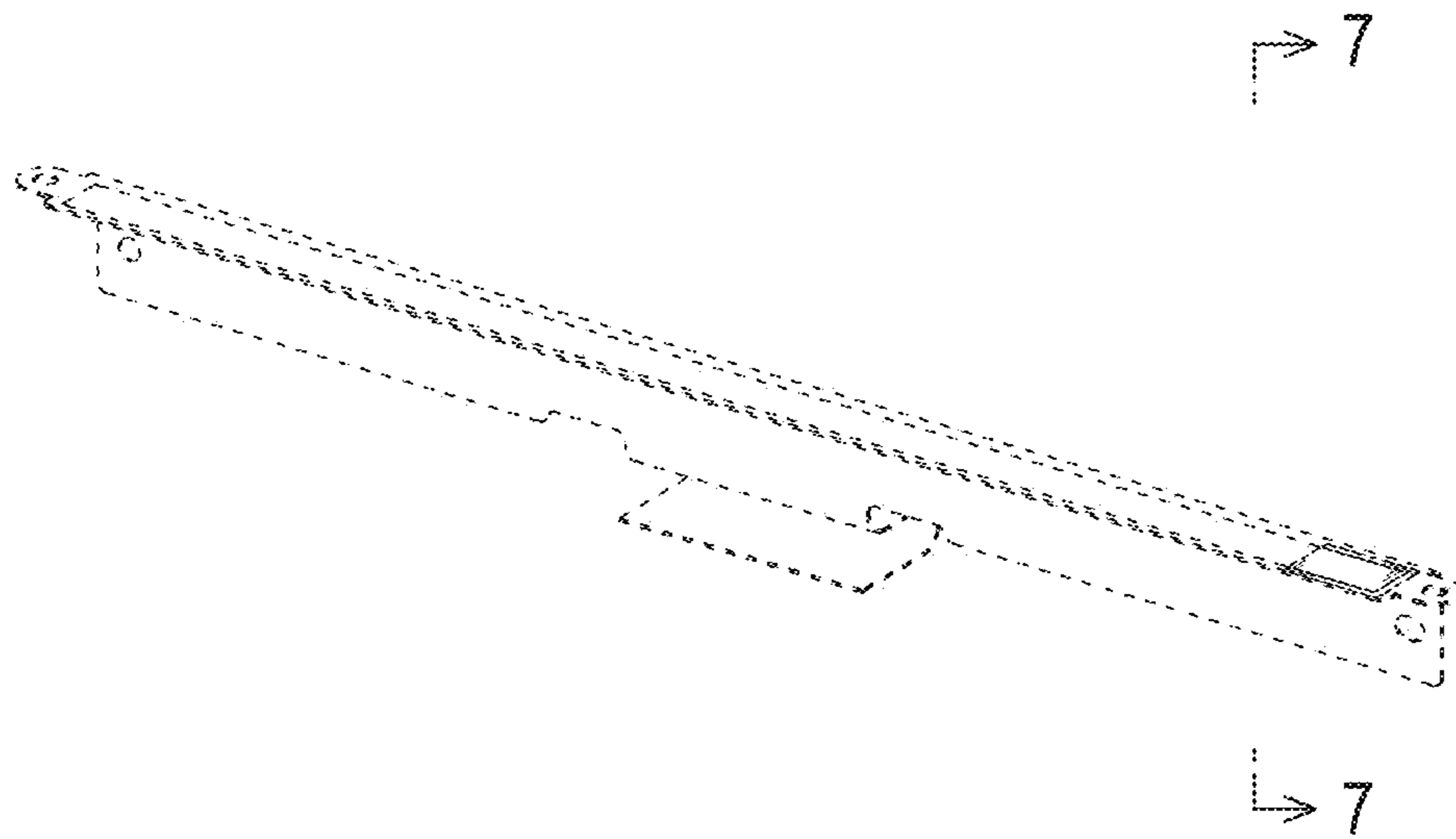

Fig.2

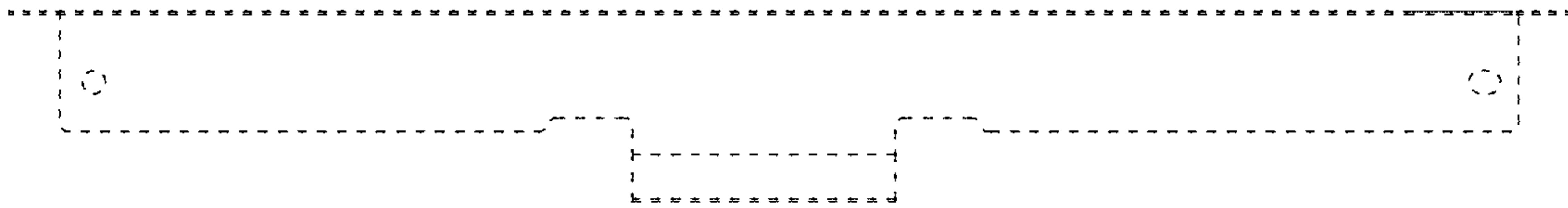

Fig.3

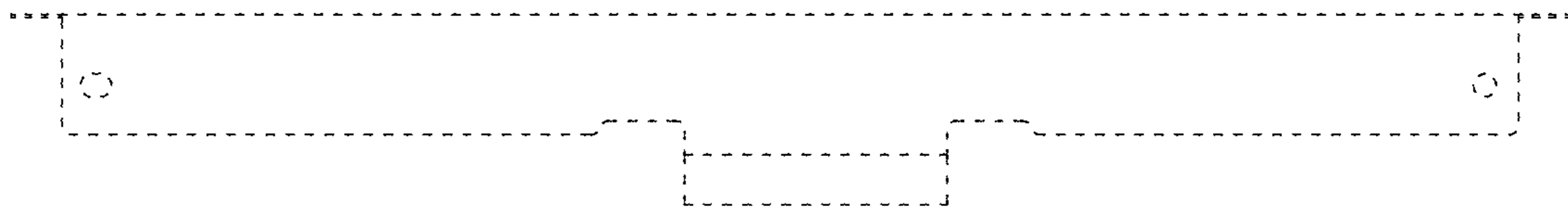

Fig.4

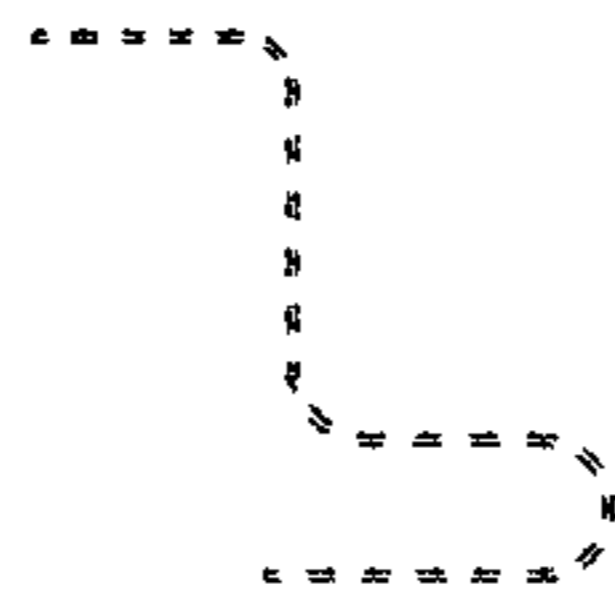

Fig.5

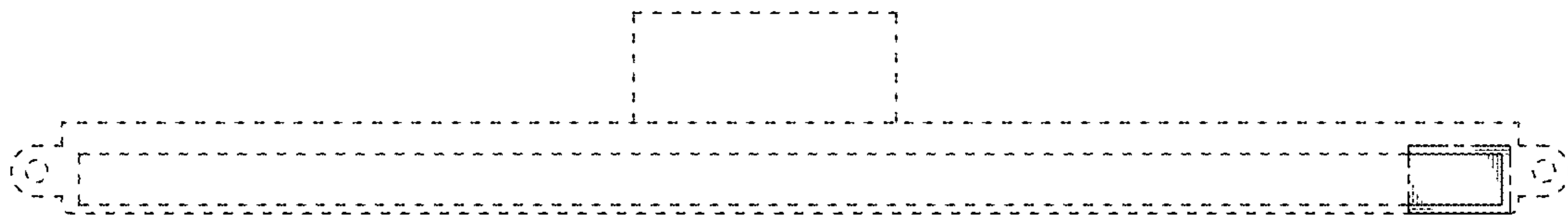

Fig.6

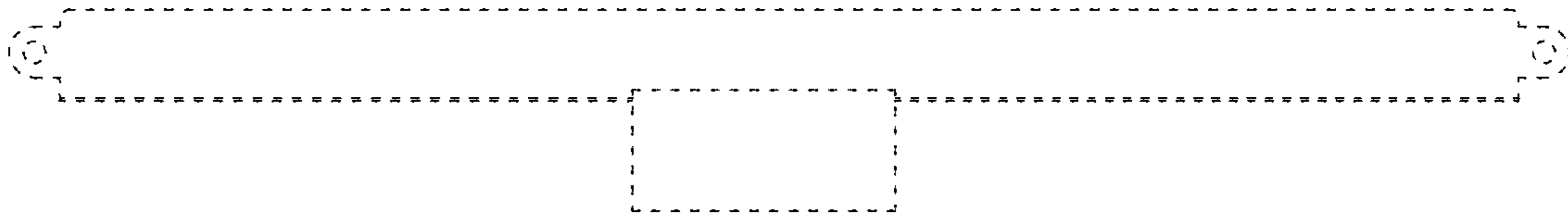

Fig.7

