



US00D963834S

(12) **United States Design Patent**  
**Daniels**

(10) **Patent No.:** **US D963,834 S**

(45) **Date of Patent:** **\*\* Sep. 13, 2022**

(54) **ROOF VENT WITH A CIRCULAR INTEGRATED FAN**

(71) Applicant: **Gregory S. Daniels**, Santa Rosa, CA (US)

(72) Inventor: **Gregory S. Daniels**, Santa Rosa, CA (US)

(\*\*) Term: **15 Years**

(21) Appl. No.: **29/756,329**

(22) Filed: **Oct. 27, 2020**

(51) **LOC (13) Cl.** ..... **23-03**

(52) **U.S. Cl.**  
USPC ..... **D23/393**

(58) **Field of Classification Search**  
USPC ..... D23/259, 260, 354, 355, 370, 371, 373, D23/381, 382, 385, 386, 387, 388, 389, D23/390, 392, 393  
CPC ..... E04D 13/152; E04F 17/026; F24F 7/02; F24F 7/025; F24F 7/065; F24F 13/00; F24F 13/02; F24F 13/0209; F24F 13/06; F24F 13/0604; F24F 13/08; F24F 13/082; F24F 13/084; F24F 13/10; F24F 13/12; F24F 13/14; F24F 13/15; F24F 13/16; F24F 13/18; F24F 13/20

See application file for complete search history.

(56) **References Cited**

U.S. PATENT DOCUMENTS

D30,059 S 1/1899 Tracy  
1,114,459 A \* 10/1914 Fritts ..... F04D 29/703 416/247 R  
1,310,537 A 7/1919 Merkel  
2,115,527 A \* 4/1938 Hueglin ..... F04D 29/646 417/362  
2,299,317 A 10/1942 Fink  
D134,477 S 12/1942 Leslie

(Continued)

FOREIGN PATENT DOCUMENTS

DE 28 04 301 2/1979  
DE 198 23 356 11/1999

(Continued)

OTHER PUBLICATIONS

TFCFL Explosion Proof Fan, Oct. 1, 2020, Amazon, site visited Dec. 12, 2021: <https://www.amazon.com/dp/B08T5YX8RJ/> (Year: 2020).\*

(Continued)

*Primary Examiner* — Jack Reickel

*Assistant Examiner* — Bobby W Jones, II

(74) *Attorney, Agent, or Firm* — Knobbe Martens Olson & Bear LLP

(57) **CLAIM**

I claim the ornamental design for roof vent with a circular integrated fan, as shown and described.

**DESCRIPTION**

FIG. 1 is a top perspective view of a roof vent with a circular integrated fan, including an upper and a lower screen; FIG. 2 is a bottom perspective view of the vent of FIG. 1; FIG. 3 is a top view of the vent of FIG. 1; FIG. 4 is a bottom view of the vent of FIG. 1; FIG. 5 is a right side view of the vent of FIG. 1; FIG. 6 is a left side view of the vent of FIG. 1; FIG. 7 is a front view of the vent of FIG. 1; FIG. 8 is a rear view of the vent of FIG. 1; FIG. 9 is a top view of another embodiment of the vent of FIG. 1, with the only difference being the lack of the upper screen; and, FIG. 10 is a bottom view of another embodiment of the vent of FIG. 1, with the only difference being the lack of the lower screen.

**1 Claim, 10 Drawing Sheets**

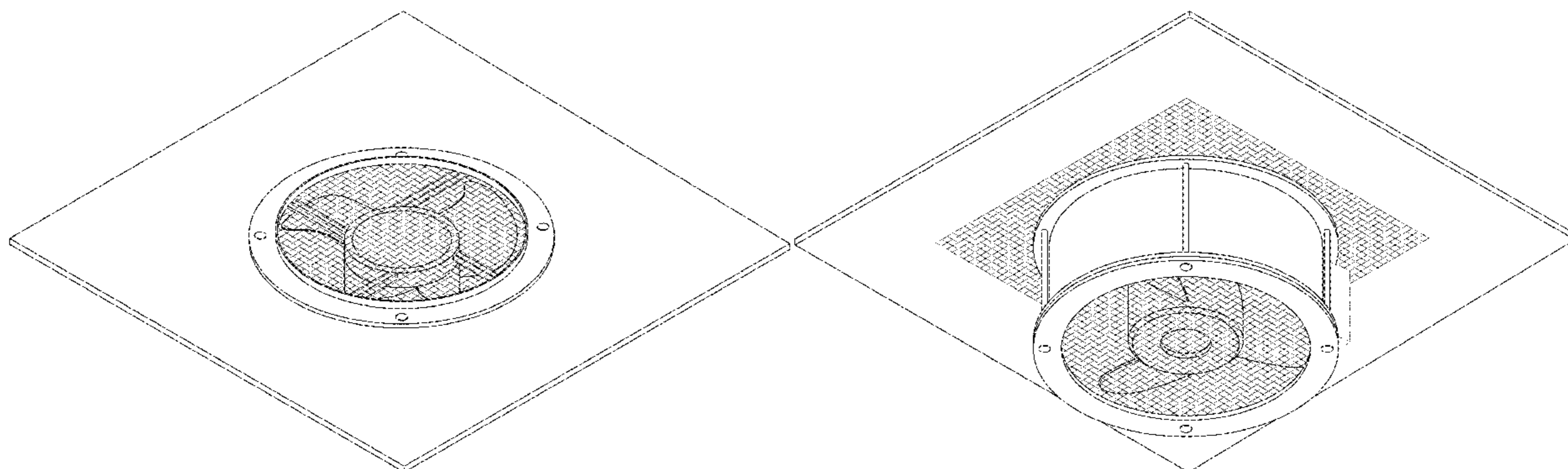

(56)

## References Cited

## U.S. PATENT DOCUMENTS

2,551,223 A	5/1951	Schneider	5,078,047 A	1/1992	Wimberly
2,638,835 A	5/1953	Strawsine	5,078,574 A	1/1992	Olsen
2,692,548 A	10/1954	Knorr	5,092,939 A	3/1992	Nath et al.
D176,891 S *	2/1956	Theisen ..... D23/385	5,094,697 A	3/1992	Takabayashi et al.
2,733,649 A	2/1956	Le Barron	5,121,583 A	6/1992	Hirai et al.
3,027,090 A	3/1962	Zerhan, Jr.	5,131,200 A	7/1992	McKinnon
3,083,633 A	4/1963	Hochberg	5,131,888 A	7/1992	Adkins, II
D204,715 S	5/1966	Martin	5,133,810 A	7/1992	Morizane et al.
3,376,164 A	4/1968	Bachwansky	D332,139 S	12/1992	Courchesne
3,459,597 A	8/1969	Baron	5,176,758 A	1/1993	Nath et al.
D215,940 S	11/1969	Kahn	5,228,925 A	7/1993	Nath et al.
D217,610 S	5/1970	Stoop	5,232,518 A	8/1993	Nath et al.
3,553,030 A	1/1971	Lebrun	5,238,519 A	8/1993	Nath et al.
3,658,596 A	4/1972	Osborne	D342,129 S	12/1993	Goetz et al.
D225,460 S *	12/1972	Altobello ..... D25/36	5,273,608 A	12/1993	Nath
3,769,091 A	10/1973	Leinkram et al.	5,296,043 A	3/1994	Kawakami et al.
3,888,697 A	6/1975	Bogus et al.	5,316,592 A	5/1994	Dinwoodie
3,895,467 A	7/1975	Clement	5,326,318 A	7/1994	Rotter
3,942,422 A	3/1976	Kawai	5,333,783 A	8/1994	Catan
3,951,336 A	4/1976	Miller et al.	5,364,026 A	11/1994	Kundert
4,040,867 A	8/1977	Forestieri et al.	5,385,848 A	1/1995	Grimmer
4,051,999 A	10/1977	Granger et al.	5,391,235 A	2/1995	Inoue
D247,510 S	3/1978	Kujawa, Jr.	5,409,549 A	4/1995	Mori
4,083,097 A	4/1978	Anagnostou et al.	5,419,781 A	5/1995	Hamakawa et al.
4,097,308 A	6/1978	Klein et al.	5,437,735 A	8/1995	Younan et al.
D249,158 S	8/1978	Morrow	5,480,494 A	1/1996	Inoue
4,108,580 A	8/1978	Felter	5,486,238 A	1/1996	Nakagawa et al.
4,189,881 A	2/1980	Hawley	5,505,788 A	4/1996	Dinwoodie
D254,442 S	3/1980	Cervone	5,528,229 A	6/1996	Mehta
4,201,121 A	5/1980	Brandenburg, Jr.	5,549,513 A	8/1996	Thomas et al.
4,224,081 A	9/1980	Kawanura et al.	D374,927 S	10/1996	Chabot et al.
4,228,729 A	10/1980	Messick	5,575,861 A	11/1996	Younan et al.
4,239,555 A	12/1980	Scharkack et al.	5,591,080 A	1/1997	Ward
4,251,026 A	2/1981	Siegel et al.	5,602,457 A	2/1997	Anderson et al.
D259,138 S	5/1981	Giles	5,620,368 A	4/1997	Bates et al.
D261,803 S	11/1981	Bohanon, Jr.	5,636,481 A	6/1997	De Zen
4,314,548 A	2/1982	Hanson	D380,823 S	7/1997	LaZar
4,382,435 A	5/1983	Brill-Edwards	5,651,226 A	7/1997	Archibald
4,383,129 A	5/1983	Gupta et al.	5,672,101 A	9/1997	Thomas
4,404,958 A	9/1983	Boettcher	5,697,192 A	12/1997	Inoue
4,418,685 A	12/1983	Frazier	5,697,842 A	12/1997	Donnelly
4,432,273 A	2/1984	Devitt	5,706,617 A	1/1998	Hirai et al.
4,433,200 A	2/1984	Jester et al.	5,722,887 A	3/1998	Wolfson et al.
4,441,651 A	4/1984	Dill	5,738,581 A	4/1998	Rickert et al.
D276,261 S	11/1984	Shaftner	5,740,636 A	4/1998	Archard
4,485,264 A	11/1984	Izu et al.	5,746,653 A	5/1998	Palmer et al.
4,498,267 A	2/1985	Beck	5,746,839 A	5/1998	Dinwoodie
4,501,194 A	2/1985	Brown	5,766,071 A	6/1998	Kirkwood
4,510,851 A	4/1985	Sarnosky et al.	D397,431 S	8/1998	Meyer
4,534,276 A	8/1985	Allison	5,800,631 A	9/1998	Yamada et al.
4,574,160 A	3/1986	Cull et al.	5,816,909 A	10/1998	Wunder
4,594,940 A	6/1986	Wolbrink et al.	D403,755 S	1/1999	Liang
4,602,739 A	6/1986	Sutton, Jr.	5,879,232 A	3/1999	Luter, II et al.
D285,829 S	9/1986	Lock	D408,514 S	4/1999	Hornig
4,625,469 A	12/1986	Gentry et al.	5,890,322 A	4/1999	Fears
4,633,769 A	1/1987	Milks	D409,741 S *	5/1999	Yuen-Ming ..... D23/370
4,651,805 A	3/1987	Bergeron, Jr.	5,968,287 A	10/1999	Nath
4,677,903 A	7/1987	Mathews, III	5,990,414 A	11/1999	Posnansky
4,692,557 A	9/1987	Samuelson et al.	6,005,236 A	12/1999	Phelan et al.
4,759,272 A	7/1988	Zaniewski	6,008,450 A	12/1999	Ohtsuka et al.
4,803,816 A	2/1989	Klober	6,036,102 A	3/2000	Pearson
4,830,791 A	5/1989	Muderlak	6,045,176 A	4/2000	Shoup
4,843,794 A	7/1989	Holtgreve	6,050,039 A	4/2000	O'Hagin
4,850,166 A	7/1989	Taylor	6,051,774 A	4/2000	Yoshida et al.
4,860,509 A	8/1989	Laaly et al.	D424,186 S	5/2000	Dodson
4,928,204 A *	5/1990	Wang ..... F24F 13/00	D424,672 S	5/2000	Nanjo
		16/443	6,057,769 A	5/2000	Stevenson
D310,874 S *	9/1990	Utley, Jr. .... D13/102	6,061,977 A	5/2000	Toyama et al.
4,965,971 A	10/1990	Jean-Jacques et al.	6,061,978 A	5/2000	Dinwoodie et al.
4,977,818 A	12/1990	Taylor et al.	6,077,159 A	6/2000	Clayton
4,986,469 A	1/1991	Sutton, Jr.	6,105,317 A	8/2000	Tomiuchi et al.
5,048,255 A	9/1991	Gonzales	6,129,628 A	10/2000	O'Hagin et al.
5,049,801 A	9/1991	Potter	6,155,006 A	12/2000	Mimura et al.
5,060,444 A	10/1991	Paquette	6,220,956 B1	4/2001	Kilian et al.
5,070,771 A	12/1991	Mankowski	D442,273 S	5/2001	Pestell
			6,241,602 B1	6/2001	Allen
			6,242,685 B1	6/2001	Mizukami et al.
			6,243,995 B1	6/2001	Reeves et al.
			D444,869 S	7/2001	Yip



(56)

References Cited

U.S. PATENT DOCUMENTS

6,294,724 B1	9/2001	Sasaoka et al.	7,507,151 B1	3/2009	Parker et al.
6,306,030 B1	10/2001	Wilson	7,509,775 B2	3/2009	Flaherty et al.
D450,378 S	11/2001	Minakuchi	7,517,465 B2	4/2009	Guha et al.
6,311,436 B1	11/2001	Mimura et al.	7,531,740 B2	4/2009	Flaherty et al.
6,336,304 B1	1/2002	Mimura et al.	D593,193 S	5/2009	Jackson
6,340,403 B1	1/2002	Carey et al.	D595,402 S	6/2009	Miyake
6,354,051 B1	3/2002	O'Hagin	7,578,102 B2	8/2009	Banister
6,365,824 B1	4/2002	Nakazima et al.	D601,237 S	9/2009	Nishio et al.
6,380,477 B1	4/2002	Curtin	7,587,864 B2	9/2009	McCaskill et al.
D457,234 S	5/2002	O'Hagin et al.	7,618,310 B2	11/2009	Daniels
D458,391 S	6/2002	O'Haqin et al.	7,642,449 B2	1/2010	Korman et al.
D458,392 S	6/2002	O'Haqin et al.	D610,245 S	2/2010	Daniels
6,415,559 B1	7/2002	Reeves et al.	D612,040 S	3/2010	Daniels
6,418,678 B2	7/2002	Rotter	7,678,990 B2	3/2010	McCaskill et al.
6,439,466 B2	8/2002	Fikes	D618,780 S	6/2010	Williams, Sr.
6,443,834 B1 *	9/2002	Berger ..... F24F 13/06	7,736,940 B2	6/2010	Basol
		454/353	7,757,440 B2	7/2010	Austin et al.
6,447,390 B1	9/2002	O'Hagin	D625,800 S	10/2010	Daniels
6,453,629 B1	9/2002	Nakazima et al.	7,901,278 B2	3/2011	O'Hagin
6,459,032 B1	10/2002	Luch	8,079,898 B1	12/2011	Stevenson
6,491,579 B1	12/2002	O'Hagin	D654,161 S	2/2012	Holland et al.
6,501,013 B1	12/2002	Dinwoodie	8,167,216 B2	5/2012	Schultz et al.
6,541,693 B2	4/2003	Takada et al.	8,186,111 B2	5/2012	Flaherty
6,553,729 B1	4/2003	Nath et al.	8,292,707 B2	10/2012	Grisham et al.
6,606,830 B2	8/2003	Nagao et al.	8,316,592 B2	11/2012	Lanza
D479,885 S	9/2003	O'Hagin et al.	D685,112 S	6/2013	Henriquez
6,695,692 B1	2/2004	York	D685,113 S	6/2013	Henriquez
D489,834 S	5/2004	Weston	8,479,458 B2	7/2013	Morita et al.
6,729,081 B2	5/2004	Nath et al.	8,535,128 B2	9/2013	Chwala
6,730,841 B2	5/2004	Heckeroth	D696,392 S	12/2013	Funnell, II
6,767,762 B2	7/2004	Guha	8,607,510 B2	12/2013	Daniels
6,799,742 B2	10/2004	Nakamura et al.	8,608,533 B2	12/2013	Daniels
D503,156 S	3/2005	Provenzano	D702,827 S	4/2014	Mase et al.
6,870,087 B1	3/2005	Gallagher	D703,305 S	4/2014	Stollenwerk et al.
D503,790 S	4/2005	Dodge et al.	8,701,360 B2	4/2014	Ressler
D504,172 S	4/2005	O'Hagin	8,740,678 B2	6/2014	Railkar et al.
6,875,914 B2	4/2005	Guha et al.	8,776,455 B2	7/2014	Azoulay
D505,195 S	5/2005	Snyder	8,782,967 B2	7/2014	Daniels
6,928,775 B2	8/2005	Banister	8,793,943 B2	8/2014	Daniels
6,941,706 B2	9/2005	Austin et al.	D713,953 S	9/2014	Jepson
D512,774 S	12/2005	O'Hagin et al.	D719,253 S	12/2014	Francescon
D518,158 S	3/2006	Cho et al.	9,011,221 B2	4/2015	Daniels
D519,219 S	4/2006	Dodge et al.	D731,047 S	6/2015	Leonard
D520,149 S	5/2006	Dodge et al.	9,074,781 B2	7/2015	Daniels
7,044,852 B2	5/2006	Horton	9,121,619 B2 *	9/2015	Potter ..... F24F 7/025
7,053,294 B2	5/2006	Tuttle et al.	D748,239 S	1/2016	Daniels
7,097,557 B2	8/2006	Kutschman	D755,944 S *	5/2016	Daniels ..... D23/373
D527,813 S	9/2006	Dodge et al.	9,394,693 B2	7/2016	Daniels
D527,836 S	9/2006	O'Hagin	D766,413 S	9/2016	Zhou et al.
7,101,279 B2	9/2006	O'Hagin et al.	D768,276 S	10/2016	Kim et al.
D536,778 S	2/2007	O'Hagin	D779,650 S	2/2017	Poehlman et al.
D537,519 S	2/2007	Sigillo	D788,281 S *	5/2017	Daniels ..... D23/373
7,176,543 B2	2/2007	Beernink	D788,902 S *	6/2017	Daniels ..... D23/373
7,178,295 B2	2/2007	Dinwoodie	D796,661 S	9/2017	Oswald
D538,422 S	3/2007	Hooijaijers et al.	D804,628 S	12/2017	Fiser
7,250,000 B2	7/2007	Daniels, II	9,869,093 B2	1/2018	Daniels
D549,316 S	8/2007	O'Hagin et al.	D810,257 S	2/2018	Lai
D555,237 S	11/2007	O'Hagin	D812,211 S *	3/2018	Daniels ..... D23/371
7,320,774 B2	1/2008	Simmons et al.	D812,213 S	3/2018	Langford
D562,440 S	2/2008	Negrao et al.	D812,216 S	3/2018	Langford
D562,993 S	2/2008	Shepherd et al.	D820,968 S	6/2018	Daniels
7,365,266 B2	4/2008	Heckeroth	D827,874 S	9/2018	Menton
7,381,129 B2	6/2008	Avedon	D841,797 S	2/2019	Daniels
D574,947 S	8/2008	Grisham	10,312,854 B2	6/2019	Daniels
D578,633 S	10/2008	Schluter et al.	D867,571 S	11/2019	Mok
D579,096 S	10/2008	Guzorek	10,465,930 B2	11/2019	Daniels
D580,542 S	11/2008	Miyake	D875,233 S *	2/2020	Sykes ..... D23/371
D582,905 S	12/2008	Takisawa et al.	D882,057 S	4/2020	Rizo
7,469,508 B2	12/2008	Ceria	D891,604 S *	7/2020	Daniels ..... D23/393
7,470,179 B1	12/2008	Ritter et al.	D899,577 S *	10/2020	Daniels ..... D23/373
D588,255 S	3/2009	Daniels	D903,089 S	11/2020	Holland
D588,256 S	3/2009	Daniels	10,830,464 B1	11/2020	Stevenson
D589,134 S	3/2009	O'Hagin et al.	2001/0027804 A1	10/2001	Inoue et al.
7,497,774 B2	3/2009	Stevenson et al.	2001/0040201 A1	11/2001	Paxton
7,506,477 B2	3/2009	Flaherty et al.	2002/0036010 A1	3/2002	Yamawaki et al.
			2002/0104562 A1	8/2002	Emoto et al.
			2003/0000158 A1	1/2003	Borges
			2003/0159802 A1	8/2003	Steneby et al.
			2004/0031219 A1	2/2004	Banister



(56)

References Cited

U.S. PATENT DOCUMENTS

2004/0098932 A1 5/2004 Broatch  
 2005/0074915 A1 4/2005 Tuttle et al.  
 2005/0127379 A1 6/2005 Nakata  
 2005/0130581 A1 6/2005 Dodge  
 2005/0144963 A1 7/2005 Peterson et al.  
 2005/0176270 A1 8/2005 Luch  
 2005/0178429 A1 8/2005 McCaskill et al.  
 2005/0191957 A1 9/2005 Demetry et al.  
 2005/0202776 A1\* 9/2005 Avedon ..... F04D 29/547  
 454/230  
 2005/0233691 A1 10/2005 Horton  
 2005/0239393 A1 10/2005 Reese  
 2005/0263178 A1 12/2005 Montello et al.  
 2005/0263179 A1 12/2005 Gaudiana et al.  
 2005/0263180 A1 12/2005 Montello et al.  
 2005/0274408 A1 12/2005 Li et al.  
 2006/0017154 A1 1/2006 Eguchi et al.  
 2006/0032527 A1 2/2006 Stevens et al.  
 2006/0052047 A1 3/2006 Daniels, II  
 2006/0052051 A1 3/2006 Daniels  
 2006/0086384 A1 4/2006 Nakata  
 2006/0124827 A1 6/2006 Janus et al.  
 2006/0199527 A1 9/2006 Peters  
 2006/0223437 A1 10/2006 O'Hagin  
 2007/0049190 A1 3/2007 Singh  
 2007/0066216 A1 3/2007 McIntire  
 2007/0067063 A1 3/2007 Ahmed  
 2007/0072541 A1 3/2007 Daniels et al.  
 2007/0084501 A1 4/2007 Kalberlah et al.  
 2007/0094953 A1 5/2007 Galeazzo et al.  
 2007/0173191 A1 7/2007 Daniels  
 2007/0178827 A1 8/2007 Erni  
 2007/0184775 A1 8/2007 Perkins  
 2007/0207725 A1 9/2007 O'Hagin  
 2007/0243820 A1 10/2007 O'Hagin  
 2007/0246095 A1 10/2007 Schaefer  
 2008/0040990 A1 2/2008 Vendig et al.  
 2008/0098672 A1 5/2008 O'Hagin et al.  
 2008/0220714 A1 9/2008 Caruso et al.  
 2008/0287053 A1 11/2008 Carlson et al.  
 2008/0287054 A1 11/2008 Carlson et al.  
 2008/0299892 A1 12/2008 Robinson  
 2009/0253368 A1 10/2009 Rotter  
 2009/0286463 A1 11/2009 Daniels  
 2009/0311959 A1 12/2009 Shepherd  
 2010/0064605 A1 3/2010 Corvaglia et al.  
 2010/0068985 A1 3/2010 Park  
 2010/0229940 A1 9/2010 Basol  
 2010/0287852 A1 11/2010 Bortoletto  
 2010/0300128 A1 12/2010 Chen  
 2010/0330898 A1\* 12/2010 Daniels ..... E04D 13/17  
 454/365  
 2011/0294412 A1 12/2011 Vagedes  
 2012/0014813 A1 1/2012 Foreman  
 2012/0110924 A1 5/2012 Makin  
 2012/0151856 A1 6/2012 Azoulay  
 2012/0178357 A1\* 7/2012 Rheume ..... F24F 7/025  
 454/343  
 2012/0190288 A1 7/2012 Willen  
 2012/0252348 A1 10/2012 Rheume  
 2012/0322359 A1 12/2012 Chen et al.  
 2013/0019548 A1 1/2013 Daniels  
 2013/0040553 A1 2/2013 Potter  
 2013/0078903 A1 3/2013 Mantyla et al.  
 2013/0247480 A1 9/2013 Ridgway  
 2014/0065944 A1 3/2014 Chamness  
 2014/0248834 A1 9/2014 Kolt et al.

2015/0099454 A1\* 4/2015 Hikmet ..... F24F 7/04  
 454/284  
 2015/0143760 A1 5/2015 Daniels  
 2015/0253021 A1\* 9/2015 Daniels ..... F24F 13/32  
 454/341  
 2016/0025361 A1 1/2016 Daniels  
 2017/0284688 A1 10/2017 Langford  
 2018/0112670 A1\* 4/2018 Trucke ..... E04H 7/24  
 2018/0216845 A1 8/2018 Whitehead  
 2019/0341879 A1 11/2019 Daniels  
 2019/0368966 A1\* 12/2019 Mizrahi ..... G01M 3/022  
 2020/0173674 A1 6/2020 Danielas  
 2020/0263905 A1 8/2020 Daniels  
 2021/0048205 A1 2/2021 Stocker  
 2021/0270475 A1\* 9/2021 Haubrich ..... F24F 11/88

FOREIGN PATENT DOCUMENTS

GB 2183819 6/1987  
 GB 2279453 1/1995  
 GB 2345536 7/2000  
 JP 59-060138 4/1984  
 JP 06-13304 U 2/1994  
 JP 06-241517 8/1994  
 JP 06-272920 9/1994  
 JP 09-158428 6/1997  
 JP 10-061133 3/1998  
 JP 11-044035 2/1999  
 JP 11-229576 8/1999  
 JP 2000-274032 10/2000  
 JP 2002-357344 12/2002  
 JP 2004-092298 3/2004  
 JP 2007-534924 11/2007  
 WO WO 05/108708 11/2005  
 WO WO 13/106882 7/2013

OTHER PUBLICATIONS

DERNORD Sanitary Gasket, Apr. 15, 2015, Amazon, site visited Dec. 12, 2021: <https://www.amazon.com/dp/B07CSXPMYC/> (Year: 2015).\*

Industrial Exhaust and Ventilation Fan, Aug. 29, 2007, Amazon, site visited Dec. 12, 2021: <https://www.amazon.com/dp/B000IJV7Y6/> (Year: 2007).\*

Flat-Type Vent. Formfonts.com[online] 1 page. Designed/built 2008 [retrieved on Feb. 12, 2015]. <[https://www.formfonts.com/3D-Model/11030/1/b3020-roof-openings/b3020-roof-openings/b3020-roof-openings/ohagins-concrete-tile-vent-type-flat/](https://www.formfonts.com/3D-Model/11030/1/b3020-roof-openings/b3020-roof-openings/b3020-roof-openings/b3020-roof-openings/ohagins-concrete-tile-vent-type-flat/)>.

Roof Vents. (1/8-Designs—© Questel). orbit.com [online PDF] 27 pages. Uploaded 2014 [retrieved on Feb. 12, 2015]. Retrieved from Internet: <<http://sobjprd.questel.fr/export/QPTUJ214/pdf2/5f7850eaf617-4548-bc47-08c3edb41caO-222833.pdf>>.

S-Type Vent. Formfonts.com[online] 1 page. Designed/built 2008 [retrieved on Feb. 12, 2015]. <<http://www.formfonts.com/3D-Model/11032/shell/b30-roofing/b3010-roof-coverings/b3020-roof-openings/ohagins-concrete-tile-vent-type/>>.

M-Type Vent. Formfonts.com[online] 1 page. Designed/built 2008 [retrieved on Feb. 12, 2015]. <<https://www.formfonts.com/3D-Model/111031/1/shell/b30-roofing/b3010-roof-coverings/b3020-roof-openings/ohagins-concrete-tile-vent-type-config/>>.

Air Vent RVG55000, Feb. 17, 2007, Amazon, site visited Dec. 12, 2021: <https://www.amazon.com/dp/B000BQPDDB/> (Year: 2007).

Dumble RV Exterior Vent, Aug. 25, 2019, Amazon, site visited Dec. 12, 2021: <https://www.amazon.com/dp/B07VWCW963/> (Year: 2019).

\* cited by examiner

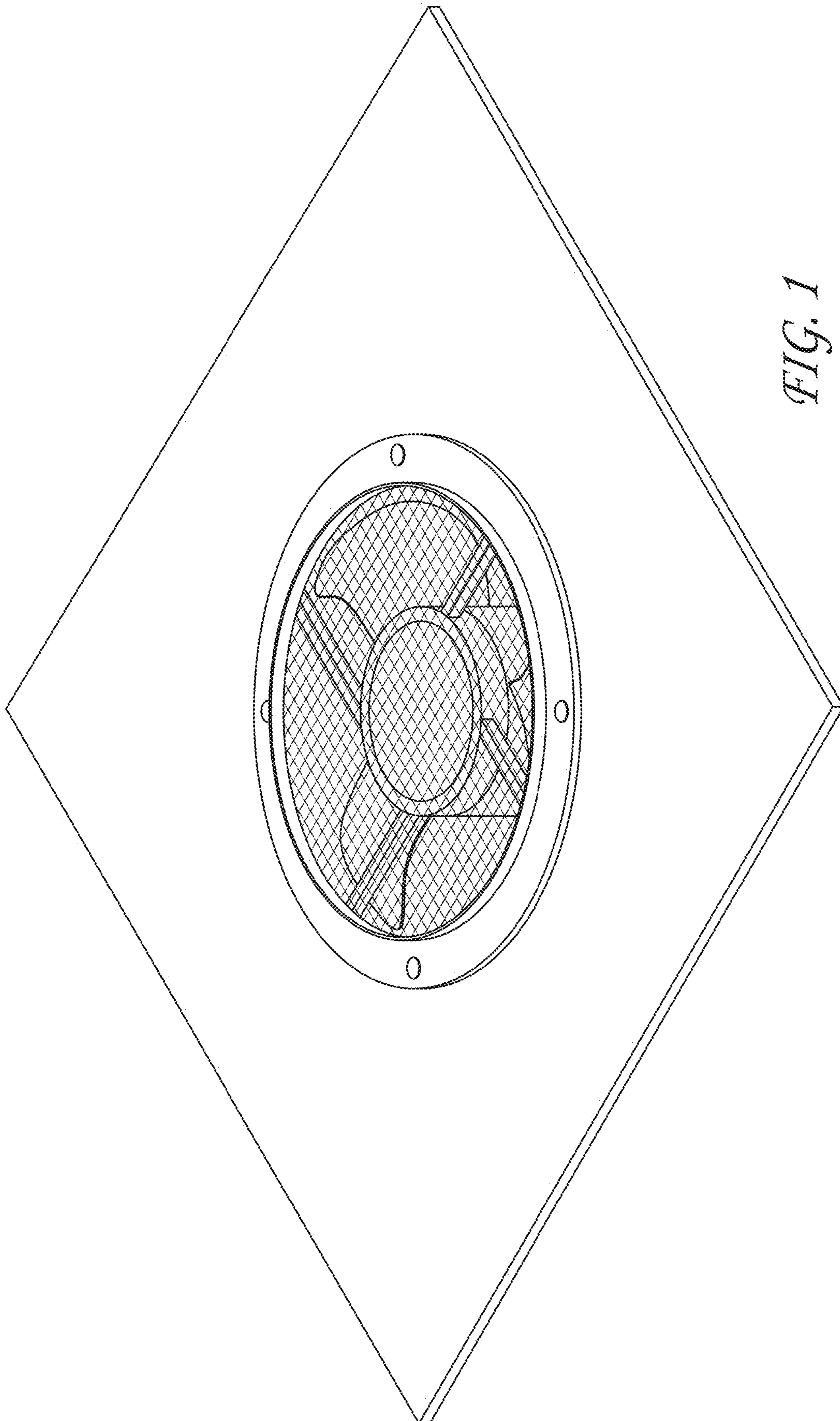

*FIG. 1*



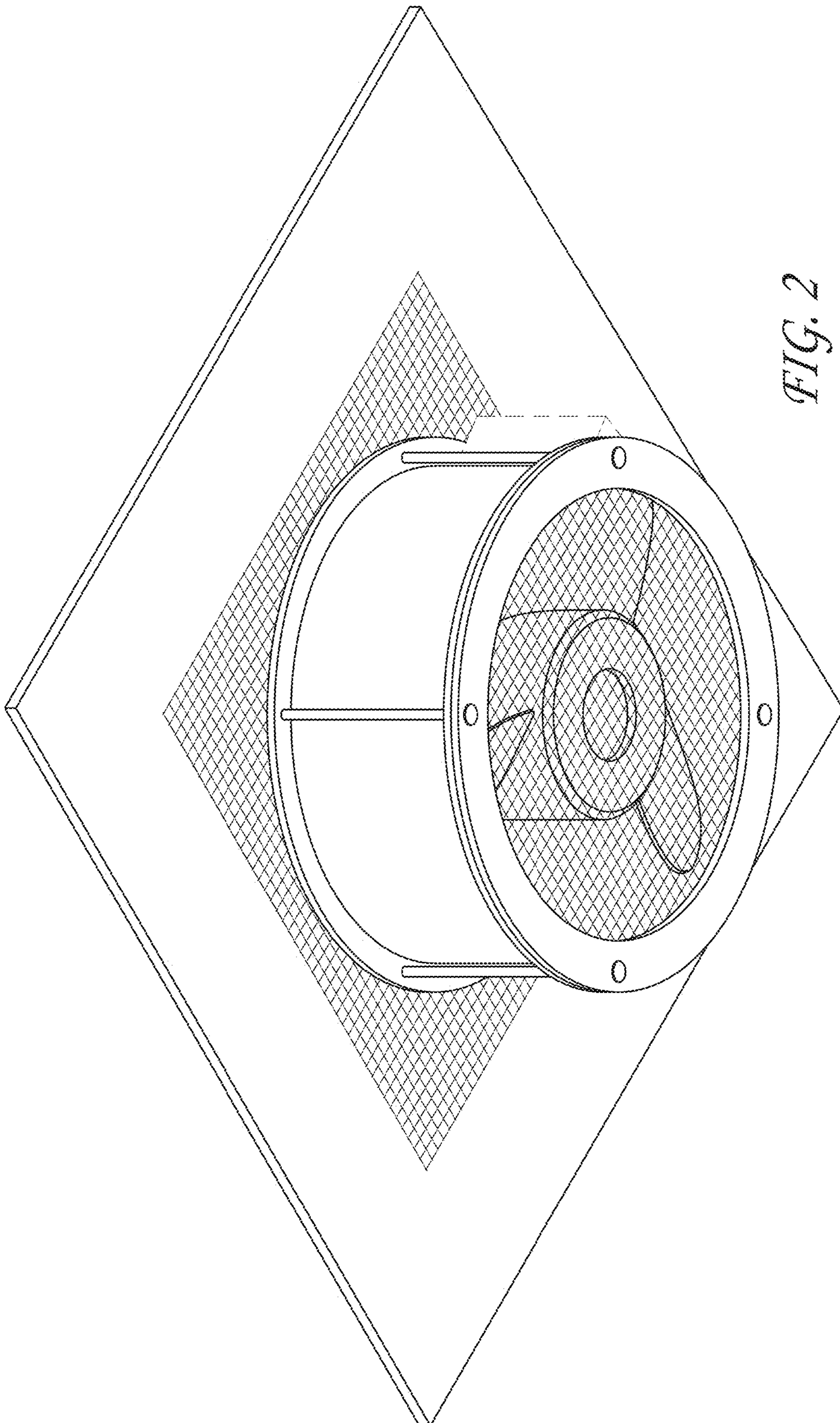
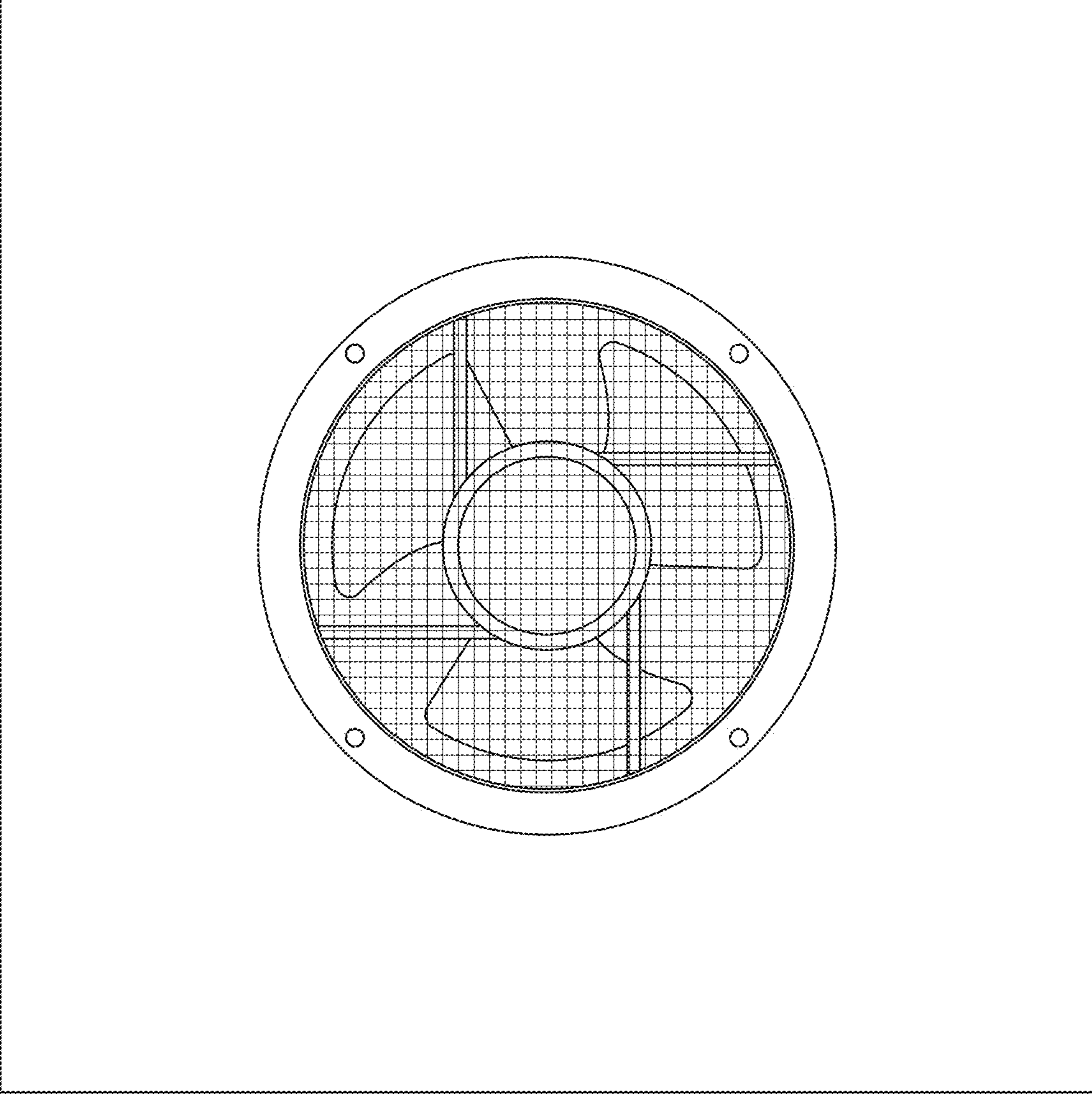
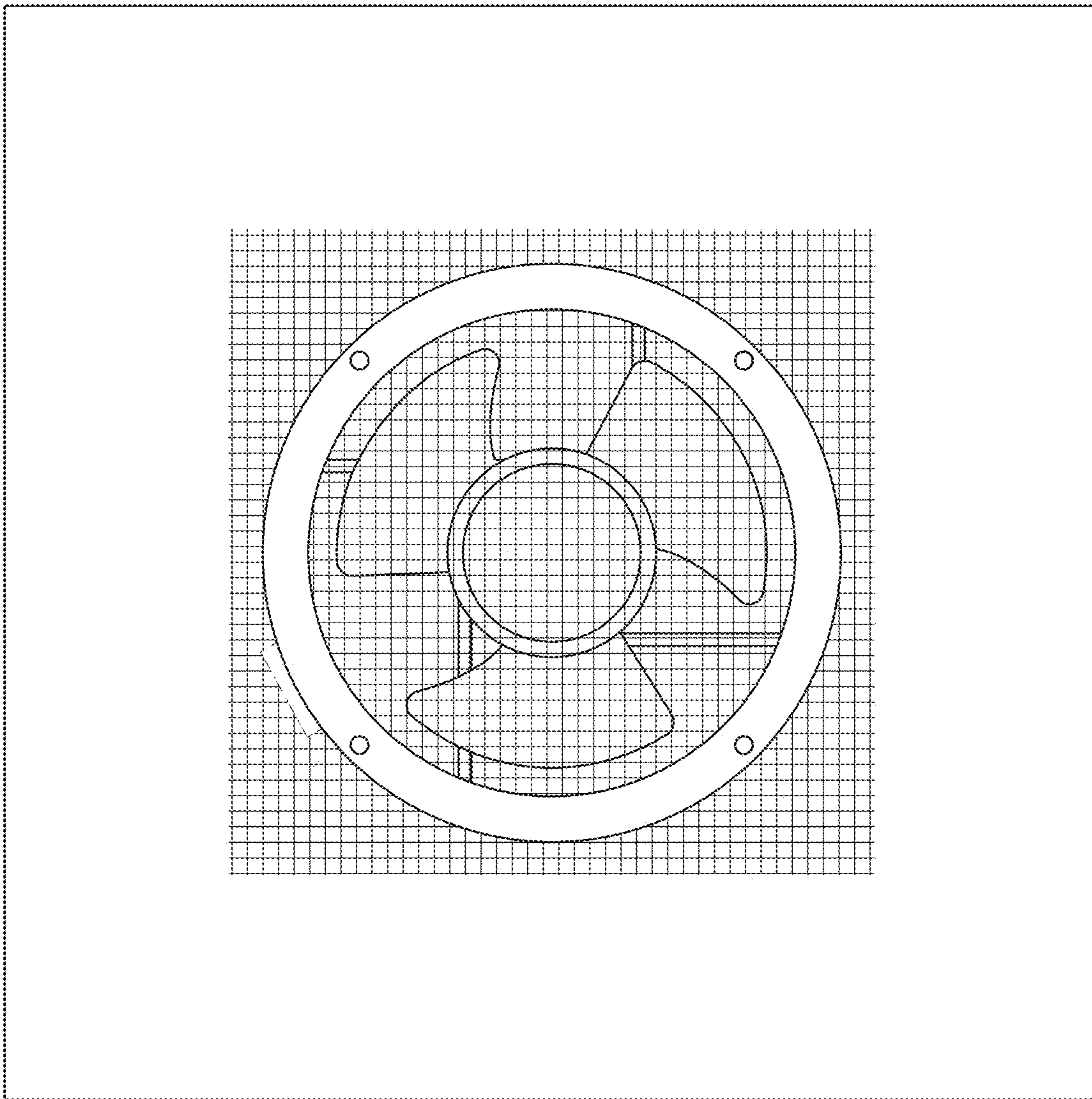

FIG. 2

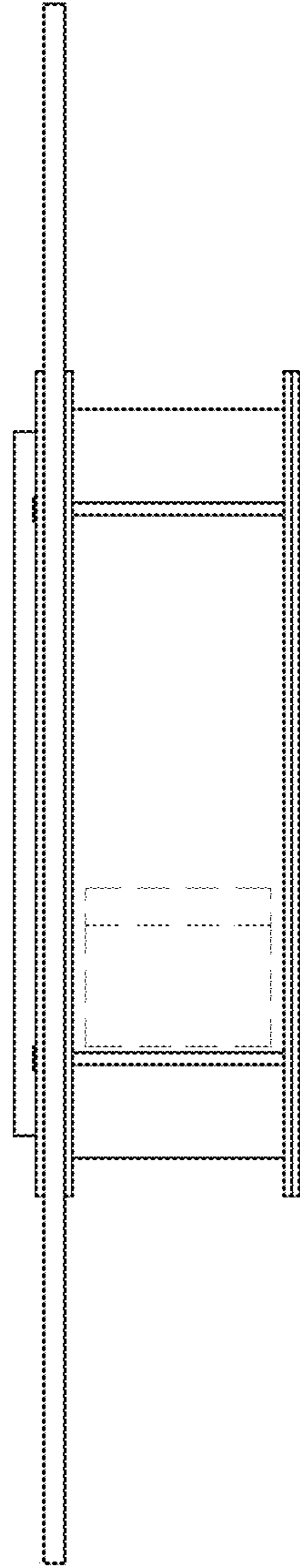

*FIG. 3*

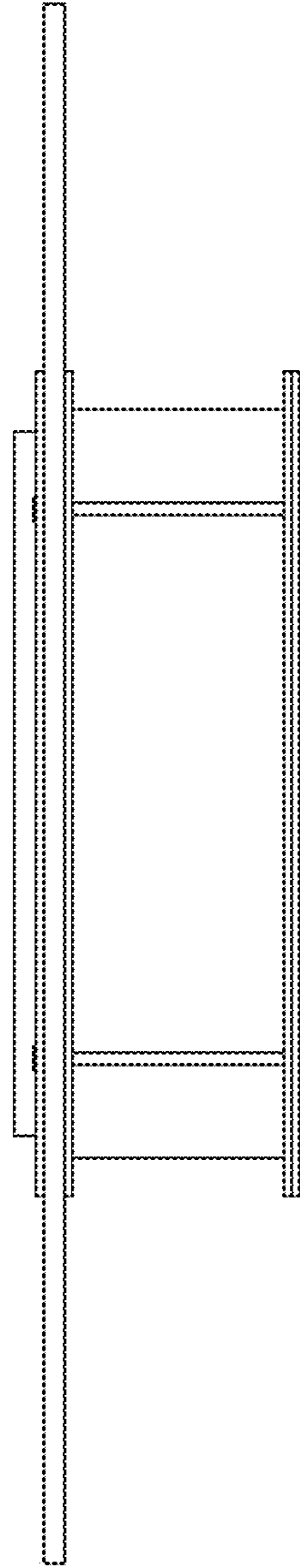

*FIG. 4*



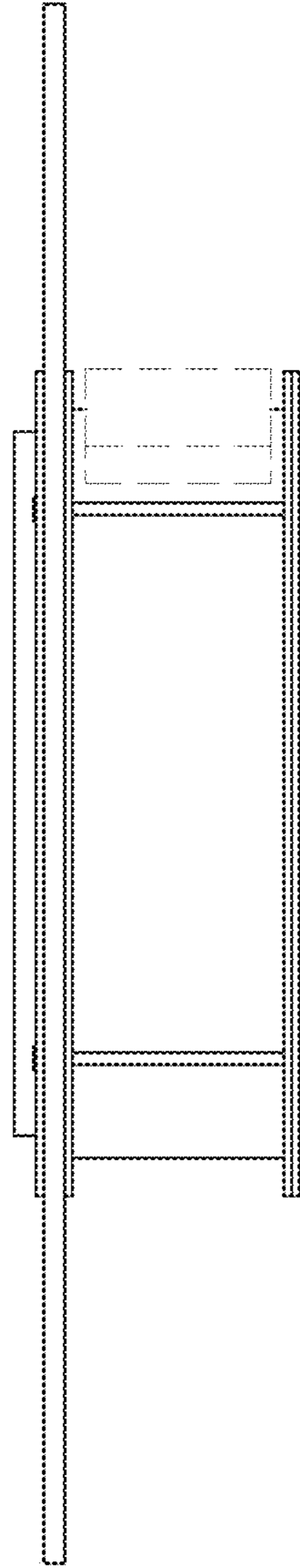

*FIG. 5*

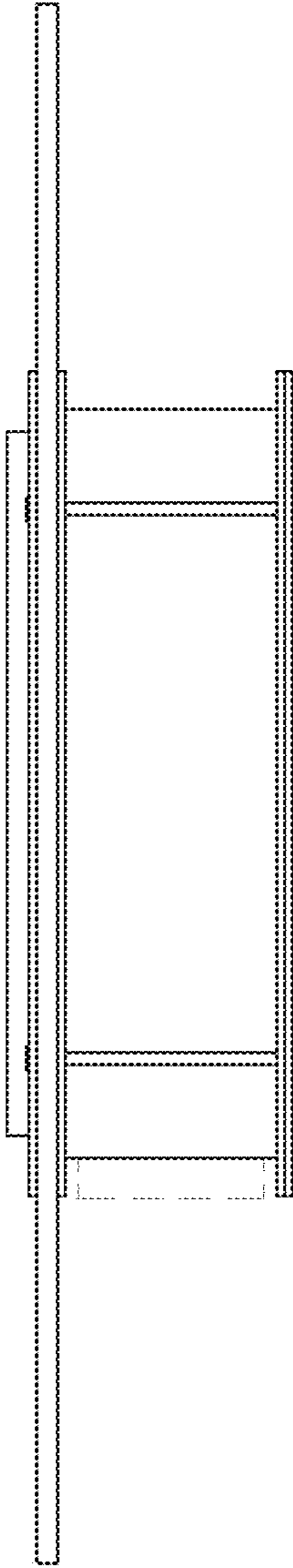

*FIG. 6*





*FIG. 7*



*FIG. 8*



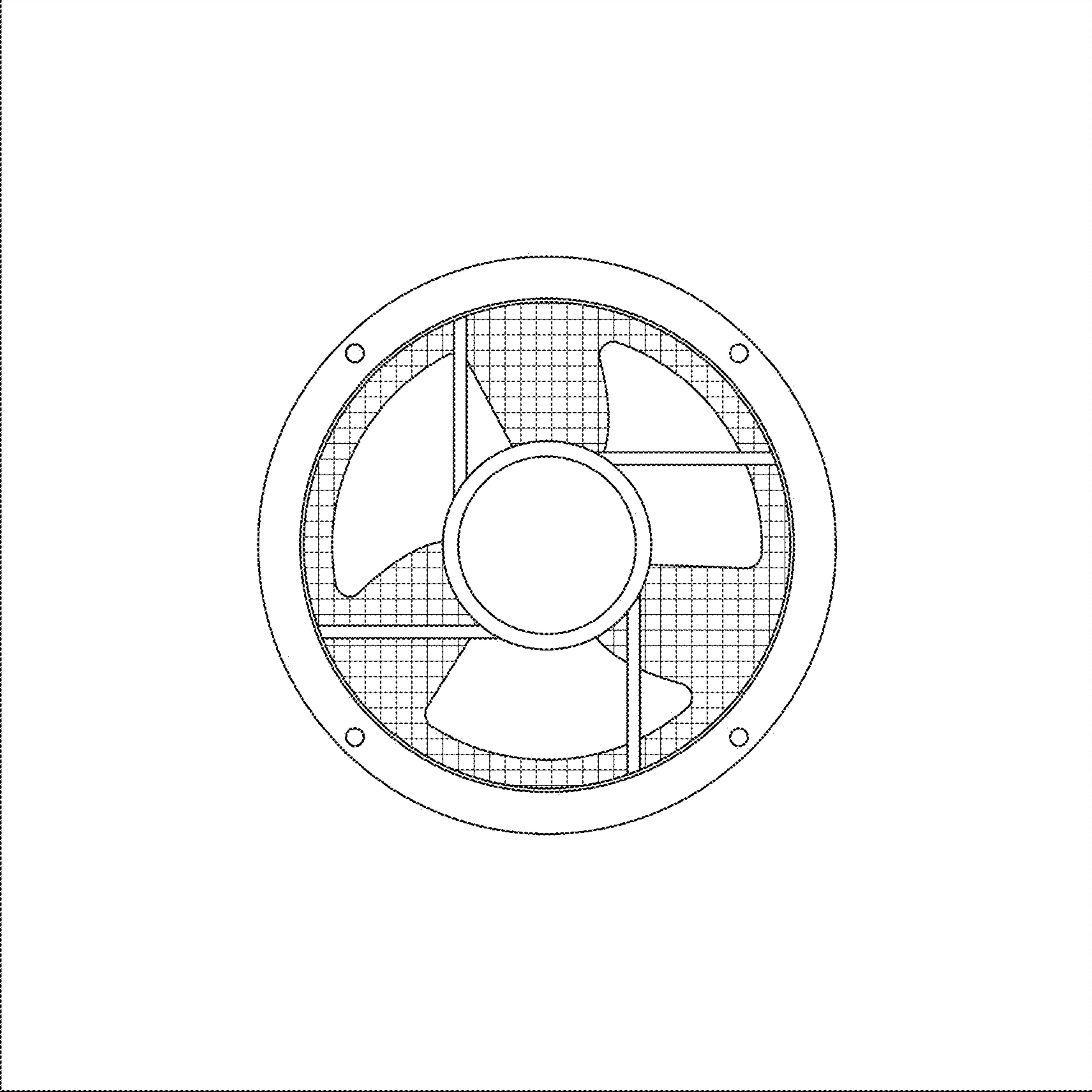
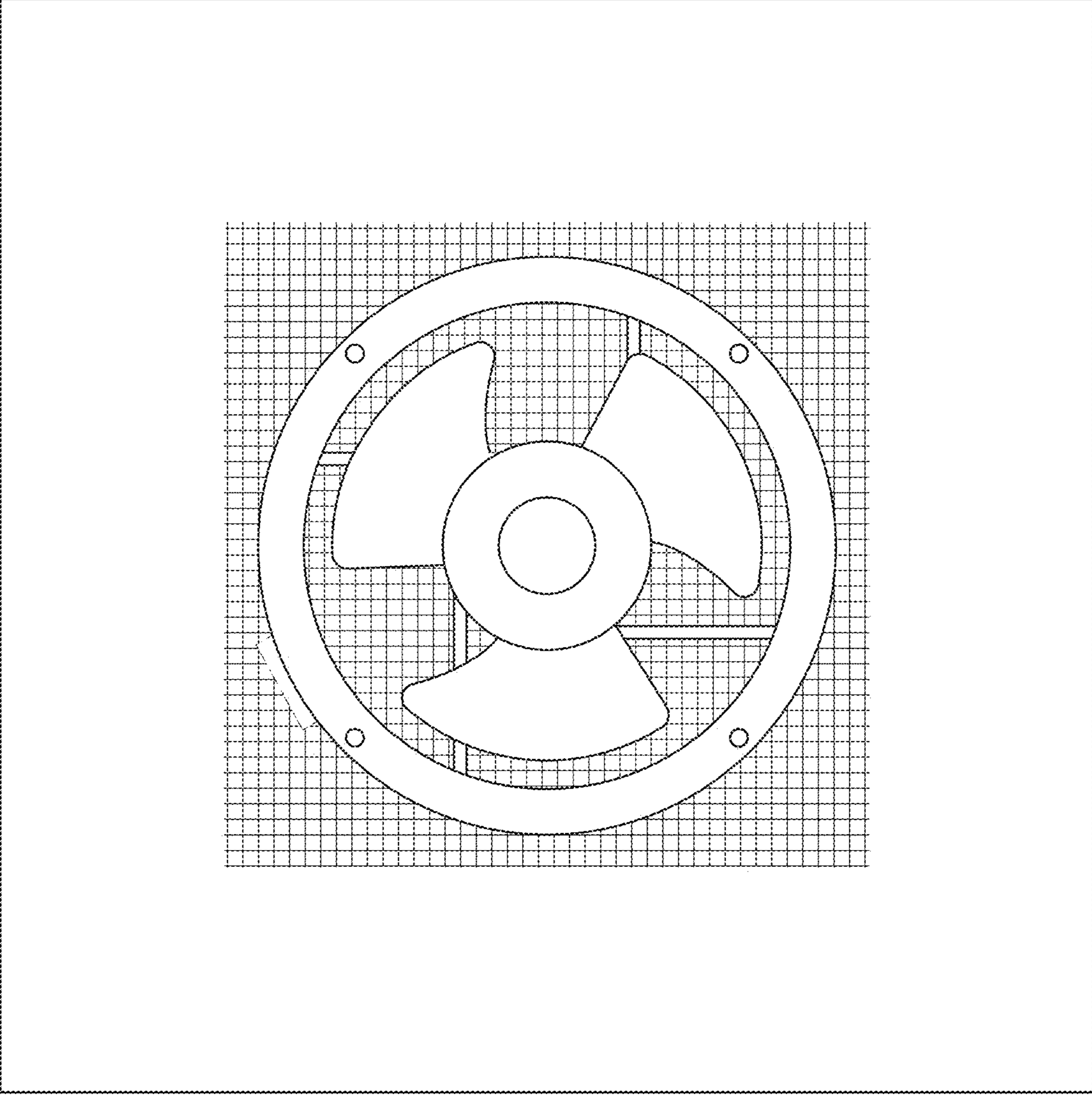

FIG. 9



*FIG. 10*