



US00D963730S

(12) **United States Design Patent**
Takano

(10) **Patent No.:** **US D963,730 S**
(45) **Date of Patent:** **** Sep. 13, 2022**

(54) **INTERCHANGEABLE LENS FOR CAMERA**

7,819,592 B2 * 10/2010 Matsuzawa H04N 5/232941
396/529

(71) Applicant: **CANON KABUSHIKI KAISHA,**
Tokyo (JP)

D665,005 S * 8/2012 Asano D16/219

D705,335 S 5/2014 Oikawa et al.

D726,240 S 4/2015 Oikawa et al.

(72) Inventor: **Seishiro Takano,** Tokyo (JP)

D745,590 S * 12/2015 Oh D16/219

D771,731 S * 11/2016 Yoshiyama D16/219

(73) Assignee: **Canon Kabushiki Kaisha,** Tokyo (JP)

(Continued)

(**) Term: **15 Years**

FOREIGN PATENT DOCUMENTS

(21) Appl. No.: **29/744,757**

JP 1456035 11/2012

JP 1456461 11/2012

(22) Filed: **Jul. 31, 2020**

(Continued)

Related U.S. Application Data

Primary Examiner — Bao-Yen T Nguyen

(74) *Attorney, Agent, or Firm* — Venable LLP

(62) Division of application No. 35/507,100, filed on Nov. 14, 2018 (U.S. filing date under 35 U.S.C. 384), and having an international filing date of Nov. 14, 2018, now abandoned.

(57) **CLAIM**

The ornamental design for an interchangeable lens for camera, as shown and described.

(30) **Foreign Application Priority Data**

May 15, 2018 (JP) 2018-010514

DESCRIPTION

(51) **LOC (13) Cl.** **16-05**

(52) **U.S. Cl.**
USPC **D16/219**

(58) **Field of Classification Search**
USPC D16/134, 136, 200, 202–205, 218, 219,
D16/235, 242

CPC G03B 17/02; G03B 19/04; G03B 17/56;
G03B 17/04; G03B 15/03; G03B 17/14;
H04N 5/2251; H04N 5/2252; H04N
5/2253; H04N 5/2254; G02B 7/02; G02B
7/04; G02B 7/14

See application file for complete search history.

FIG. 1 is a Front view of an interchangeable lens for camera showing my new design;

FIG. 2 is a Back view thereof;

FIG. 3 is a Top view thereof;

FIG. 4 is a Bottom view thereof;

FIG. 5 is a Left side view thereof;

FIG. 6 is a Right side view thereof;

FIG. 7 is a Front Perspective view thereof;

FIG. 8 is a Front view thereof;

FIG. 9 is an enlarged partial view thereof; and,

FIG. 10 is an enlarged sectional view thereof.

The dashed broken lines show portions of the interchangeable lens for camera that form no part of the claimed design.

The dashed-dotted broken lines define a boundary of the design that forms no part of the claimed design.

(56) **References Cited**

U.S. PATENT DOCUMENTS

D412,922 S * 8/1999 Sekine D16/134

D420,029 S * 2/2000 Kimura D16/134

1 Claim, 10 Drawing Sheets

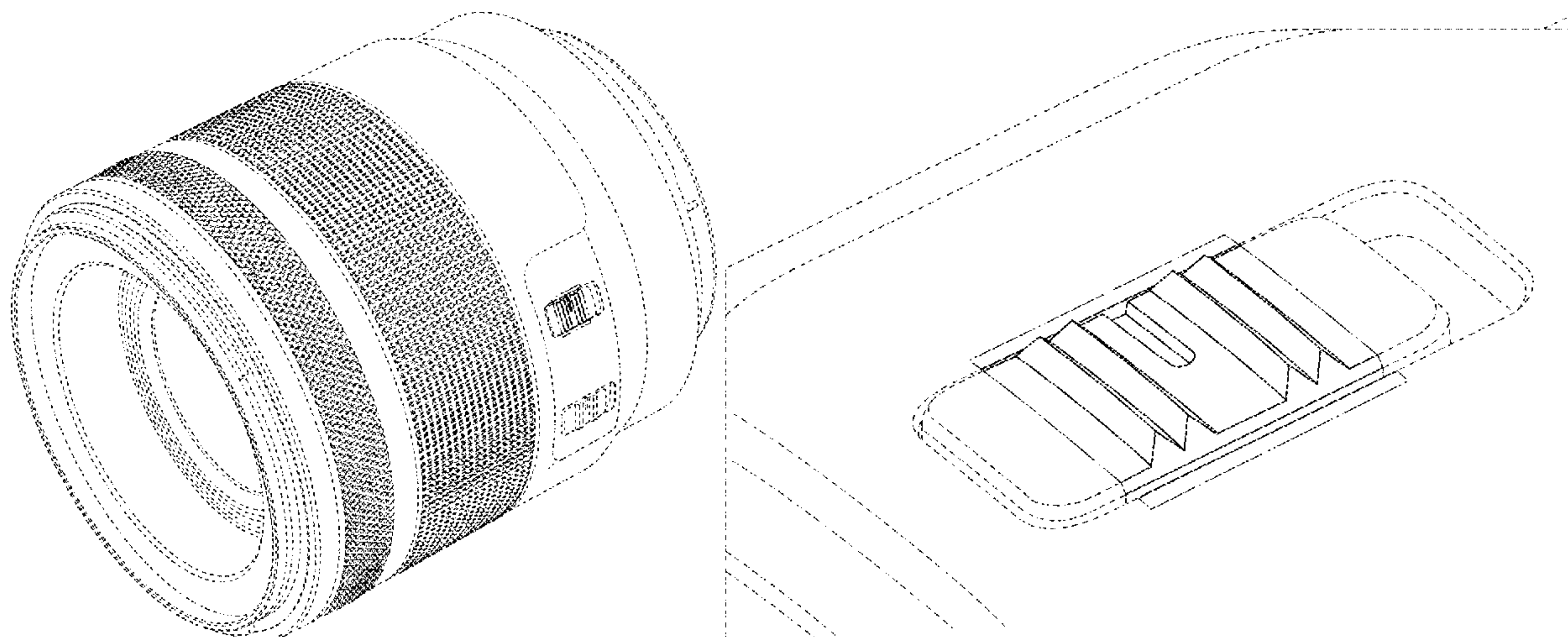

(56)

References Cited

U.S. PATENT DOCUMENTS

D775,680	S	*	1/2017	Yoshiyama	D16/219
D783,700	S		4/2017	Tagawa et al.	
D786,954	S	*	5/2017	Tagawa	D16/219
D794,107	S	*	8/2017	Tagawa	D16/219
D801,409	S	*	10/2017	Tsuge	D16/219
D823,924	S	*	7/2018	Ikegame	D16/219
D836,152	S	*	12/2018	Ikegame	D16/219
D837,277	S	*	1/2019	Ikegame	D16/219
D867,430	S	*	11/2019	Ikegame	D16/219
D868,134	S	*	11/2019	Kamei	D16/219
D881,261	S	*	4/2020	Ikegame	D16/219
D915,491	S	*	4/2021	Isozaki	D16/219

FOREIGN PATENT DOCUMENTS

JP	1456462	11/2012
JP	1456463	11/2012
JP	1456464	11/2012
JP	1456465	11/2012
JP	1555184	8/2016
JP	2016-126069 A	7/2017

* cited by examiner

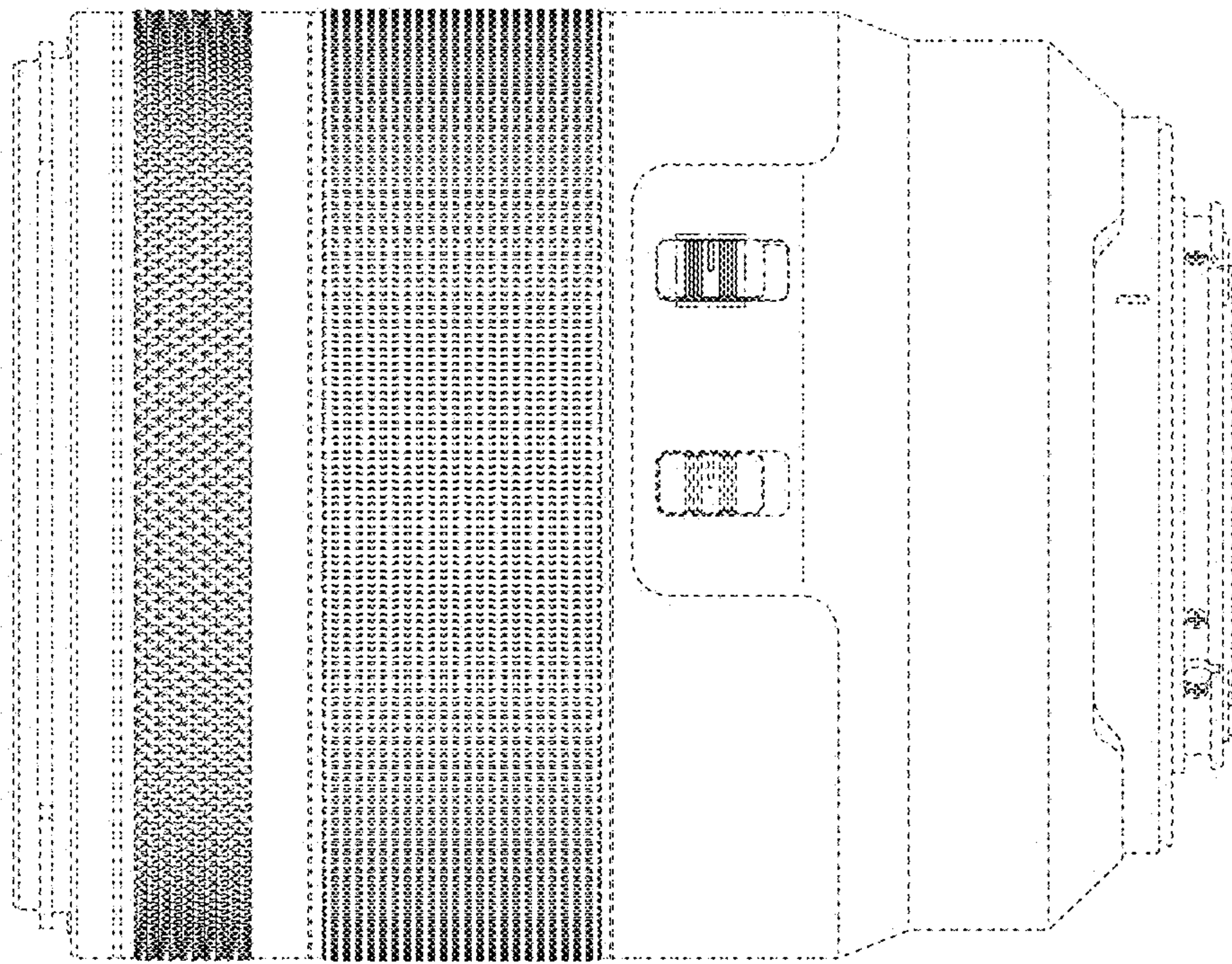

FIG. 1

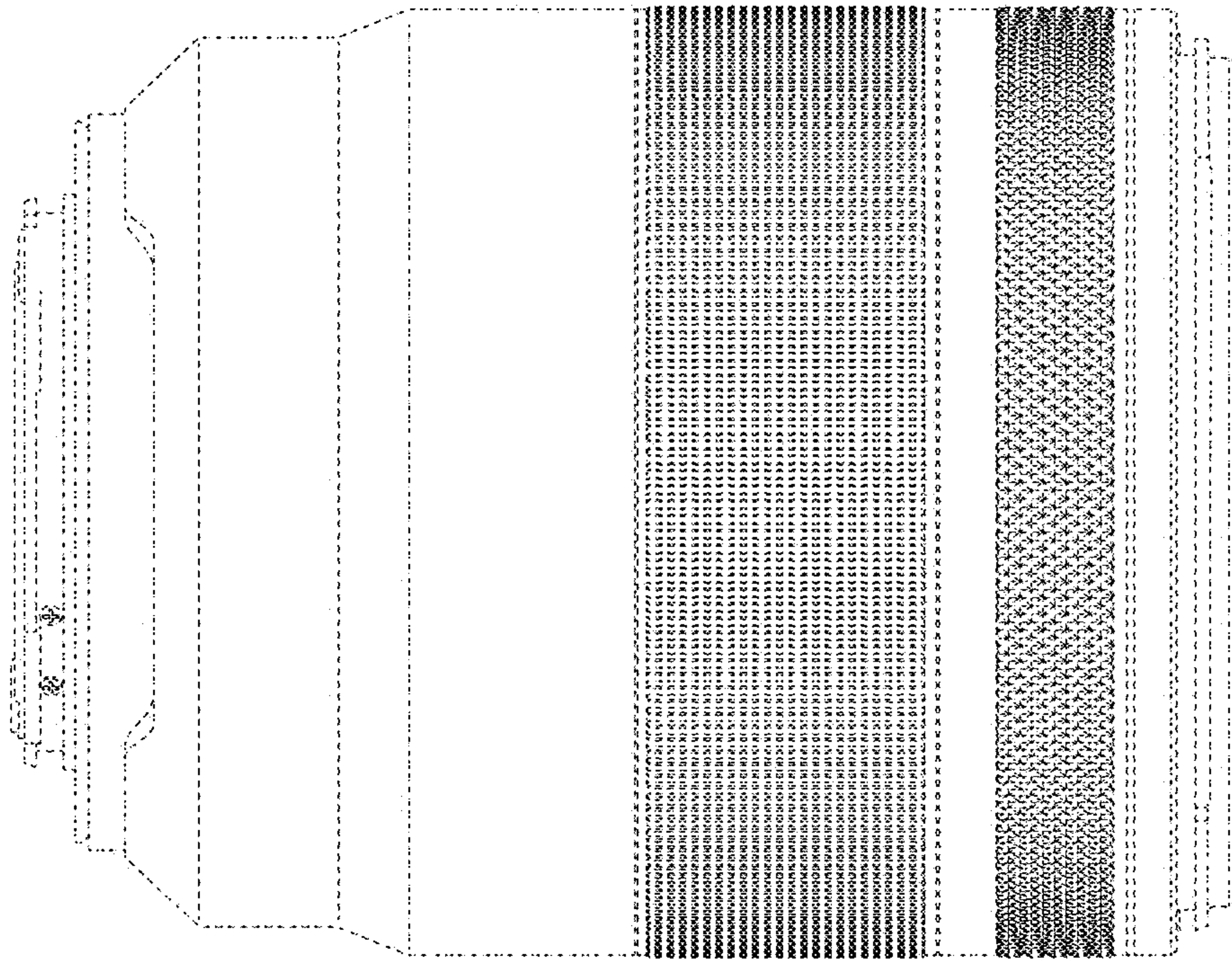

FIG. 2

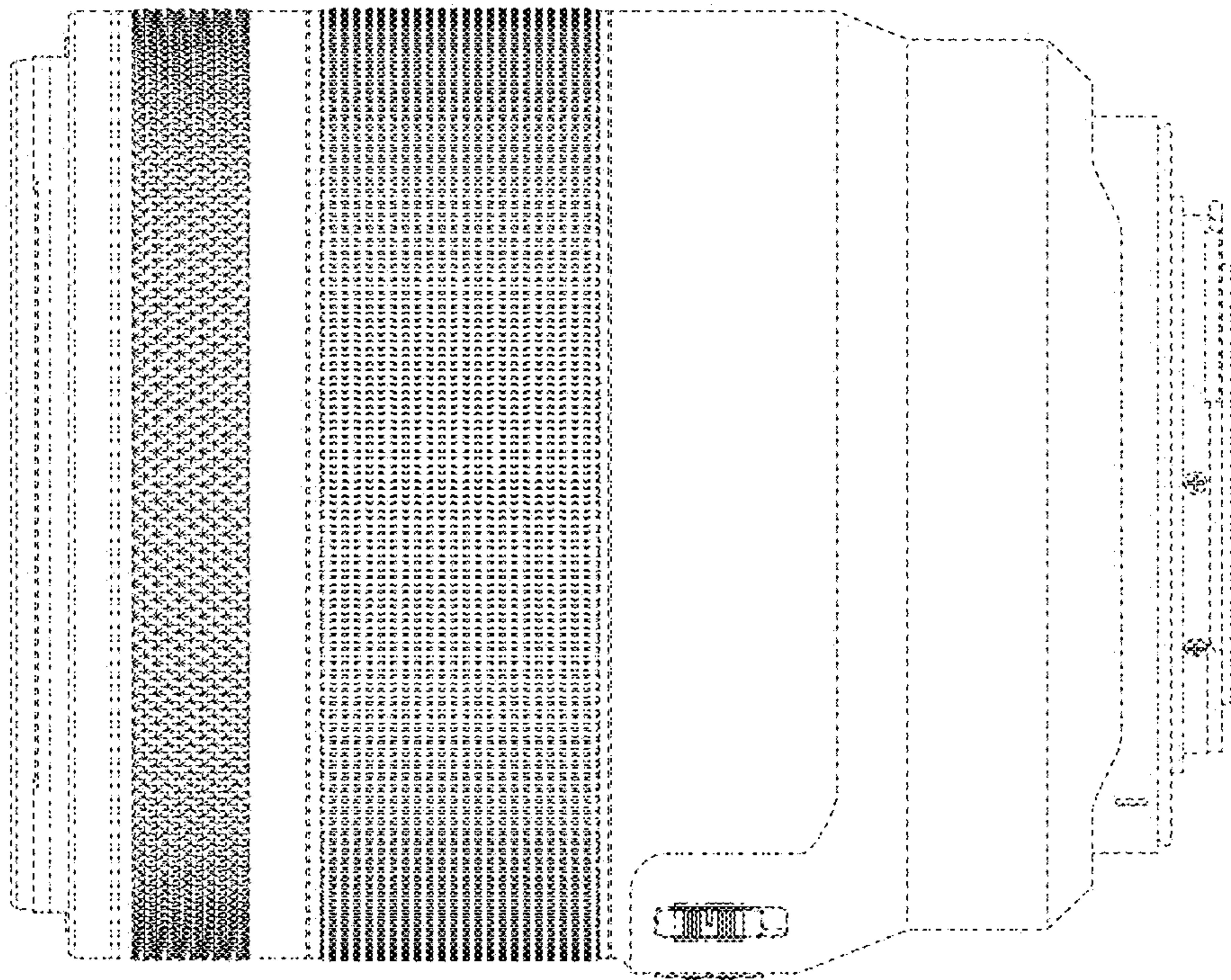

FIG. 3

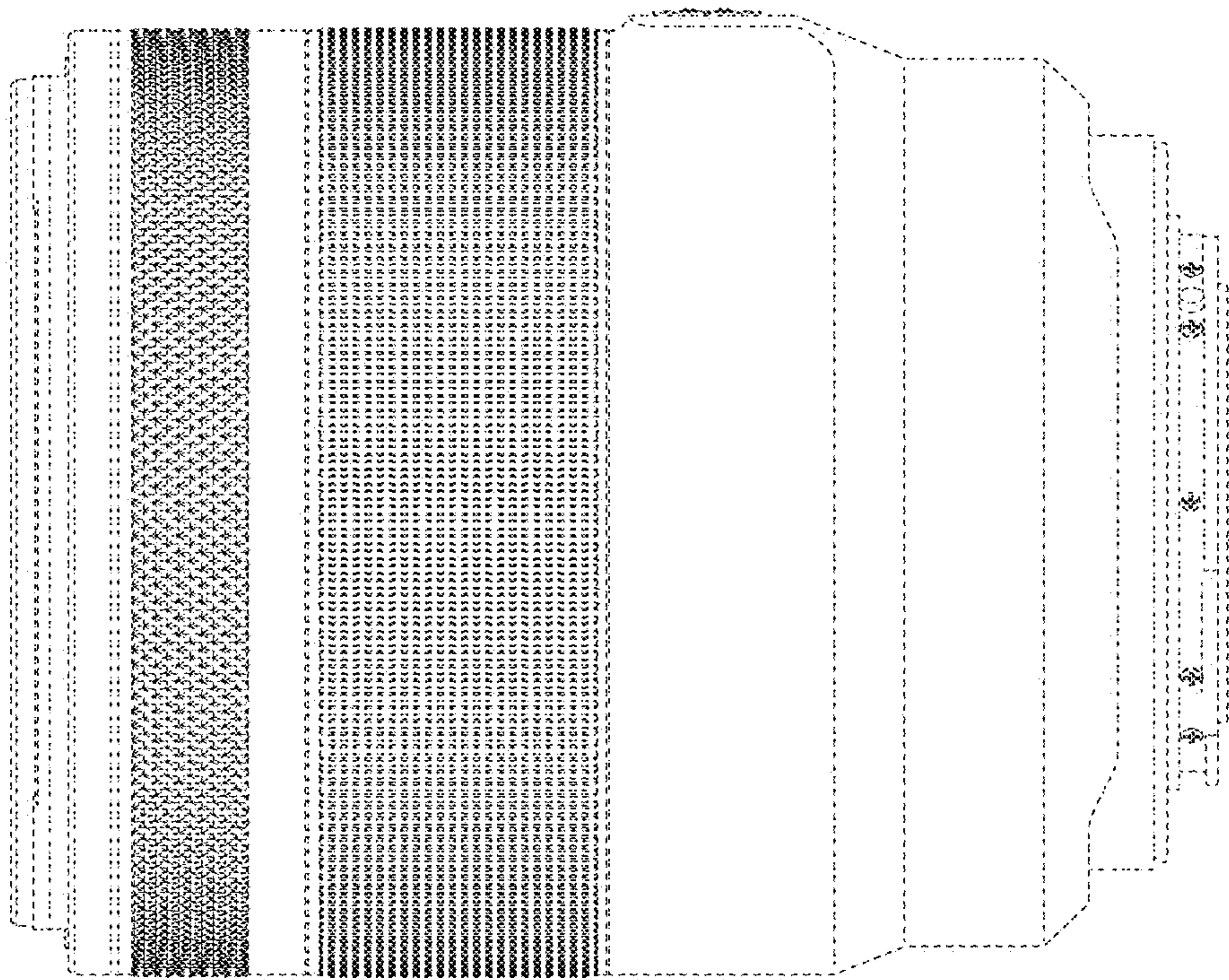

FIG. 4

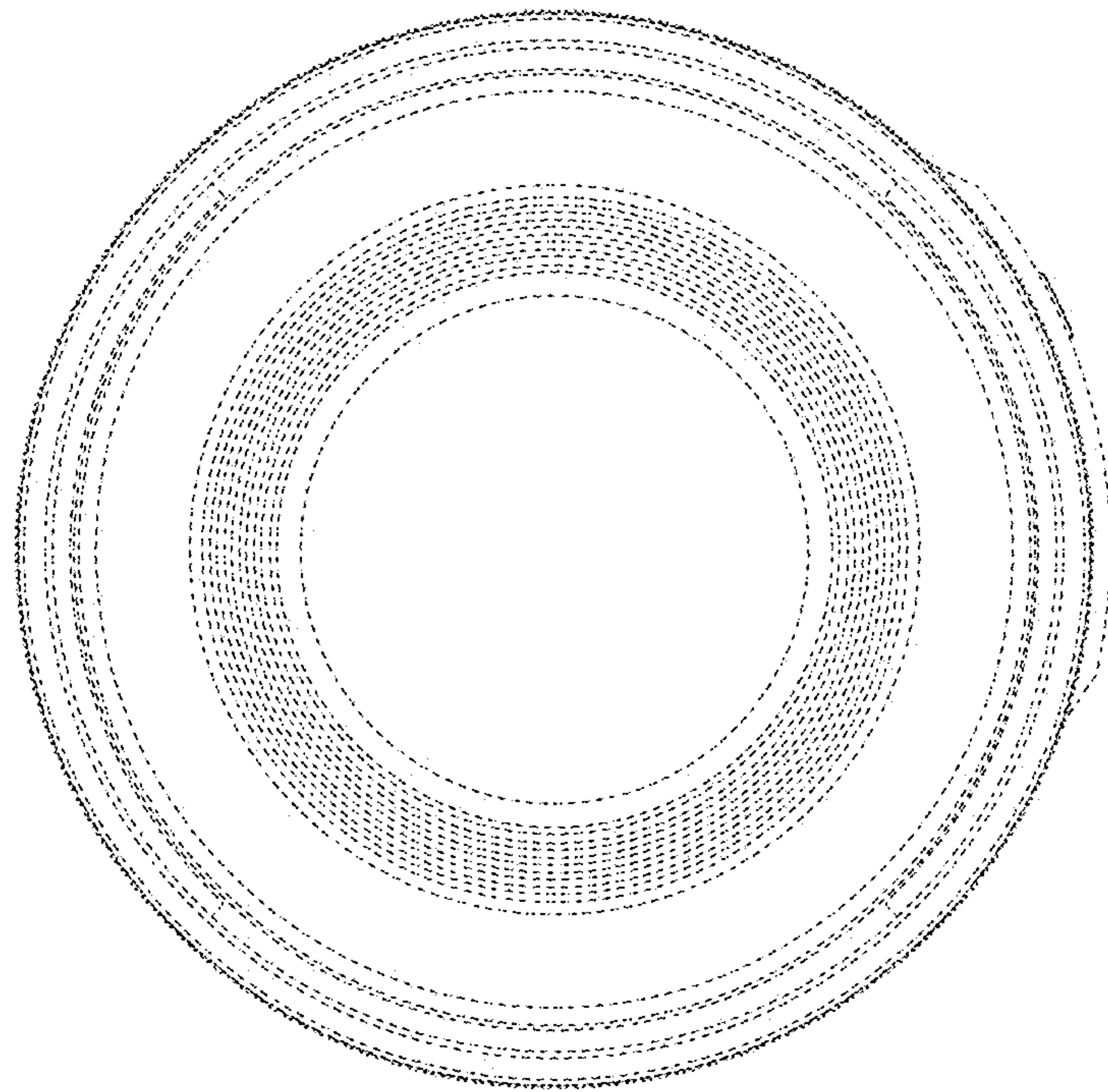

FIG. 5

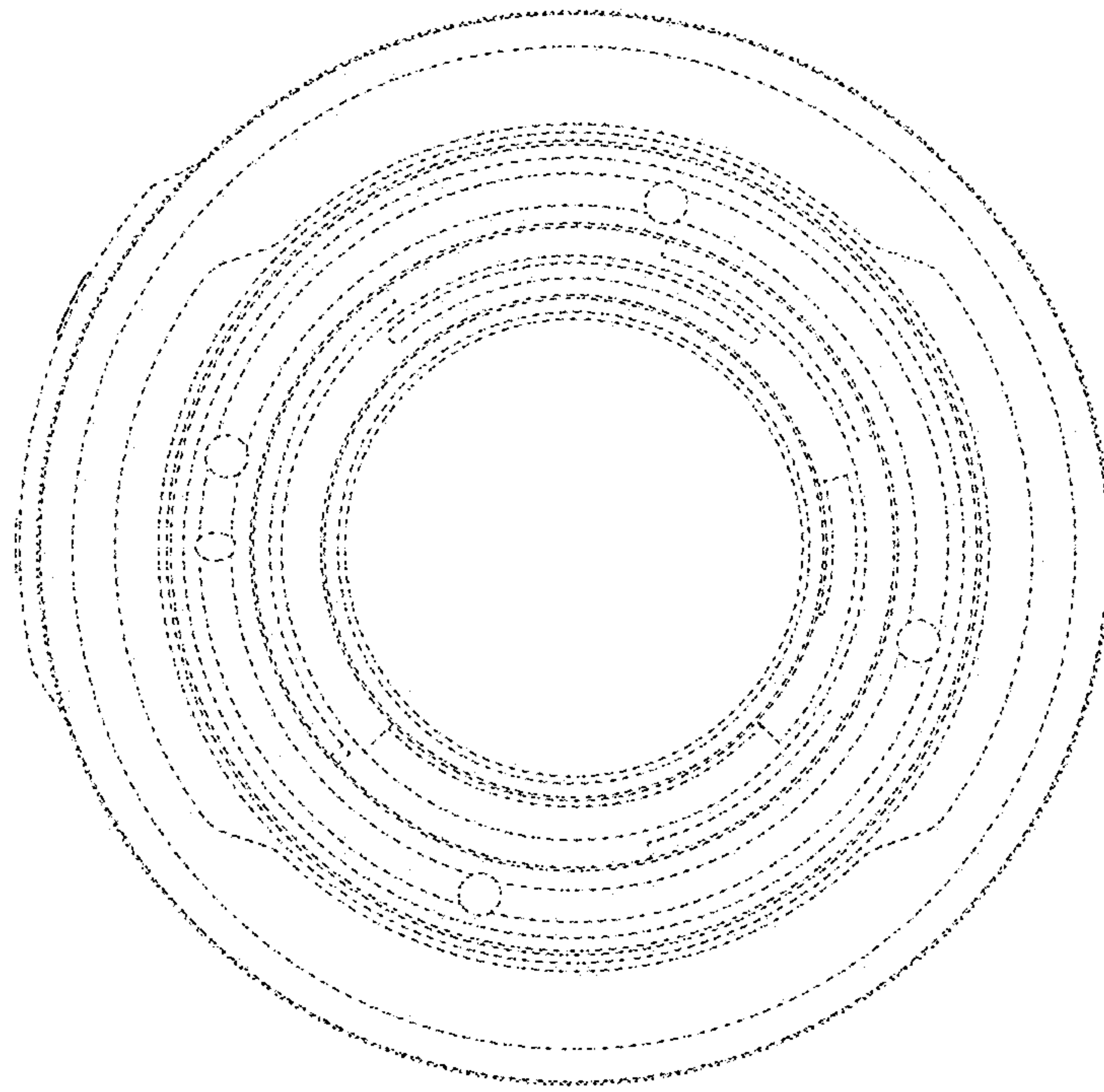

FIG. 6

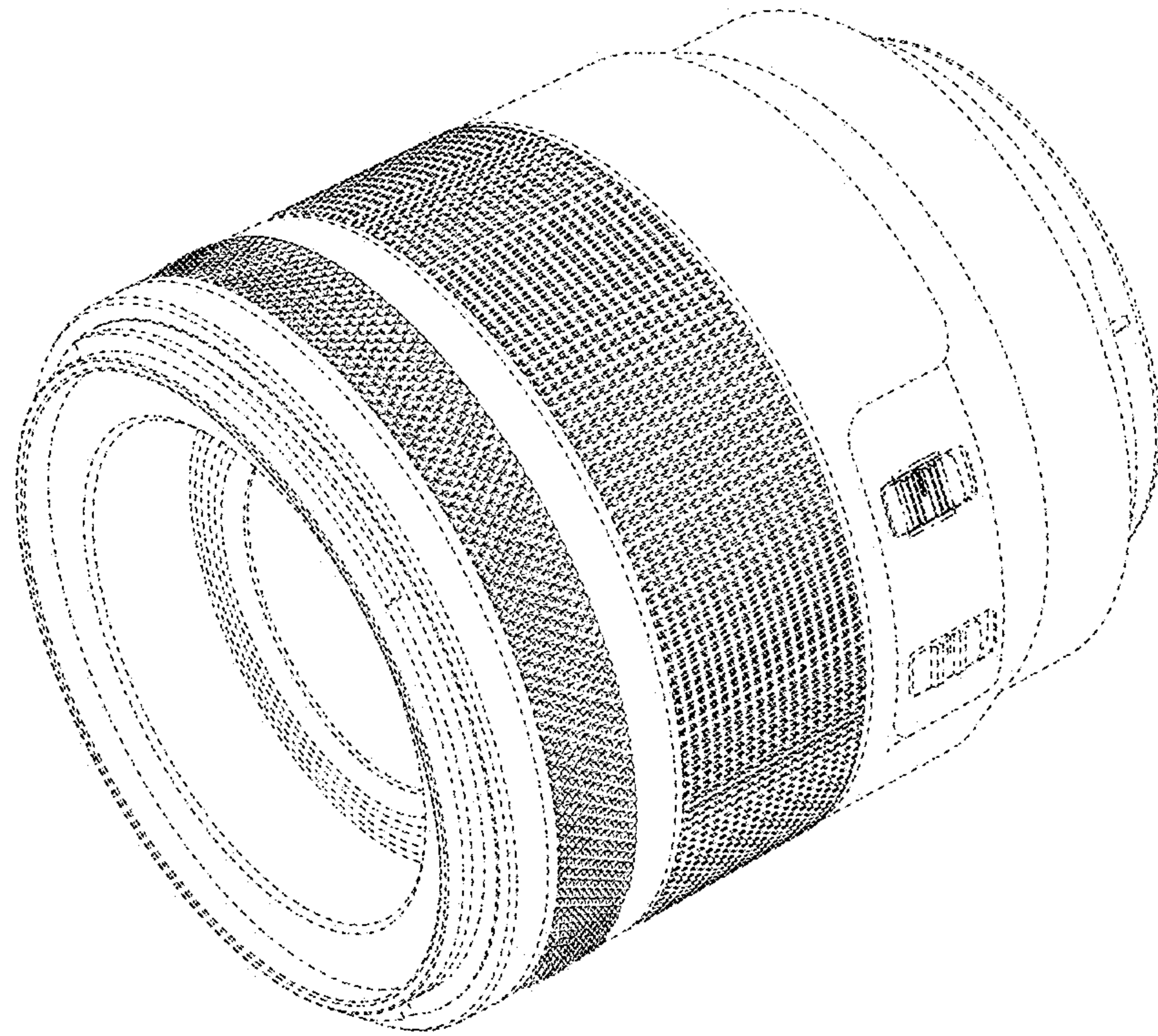

FIG. 7

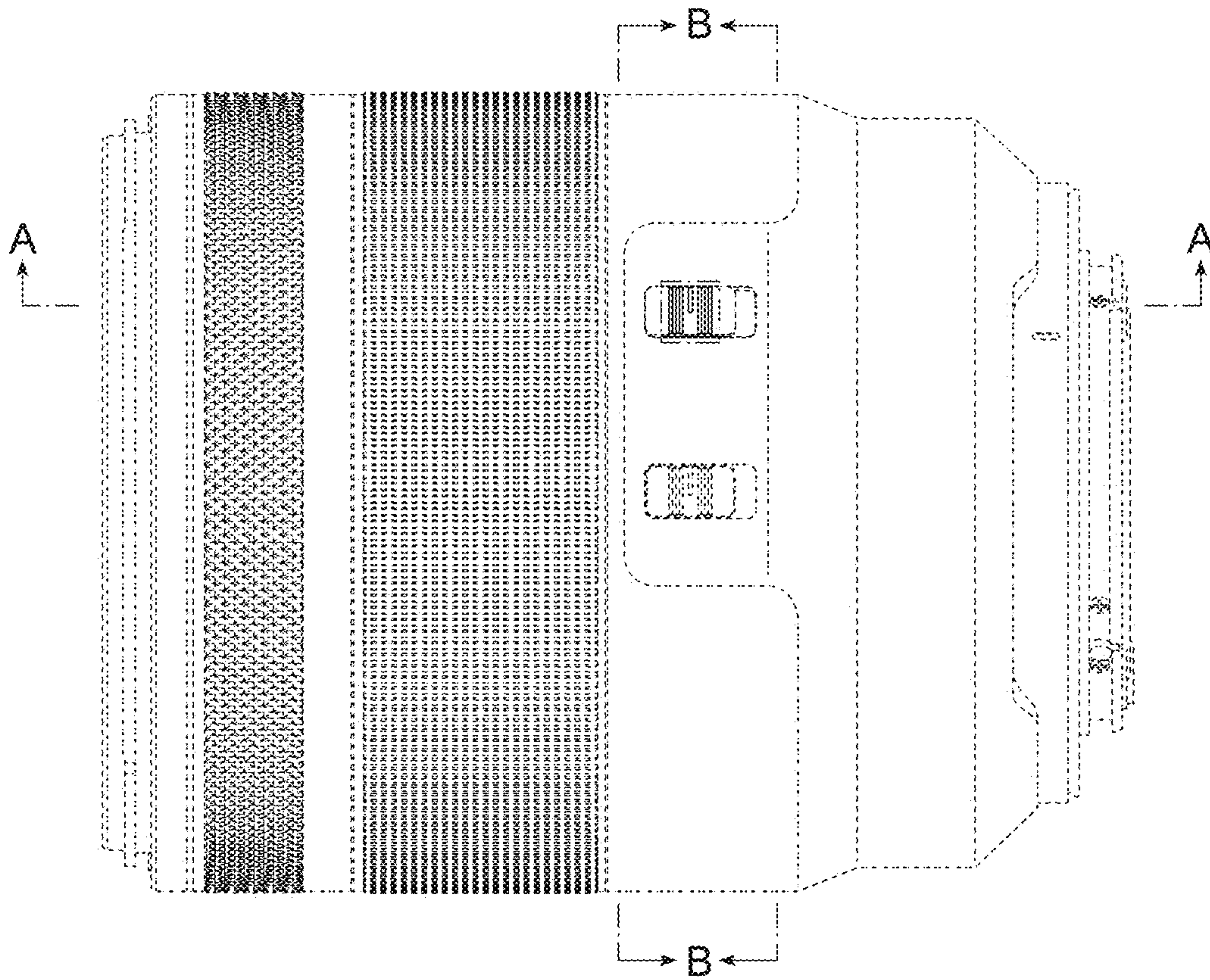

FIG. 8

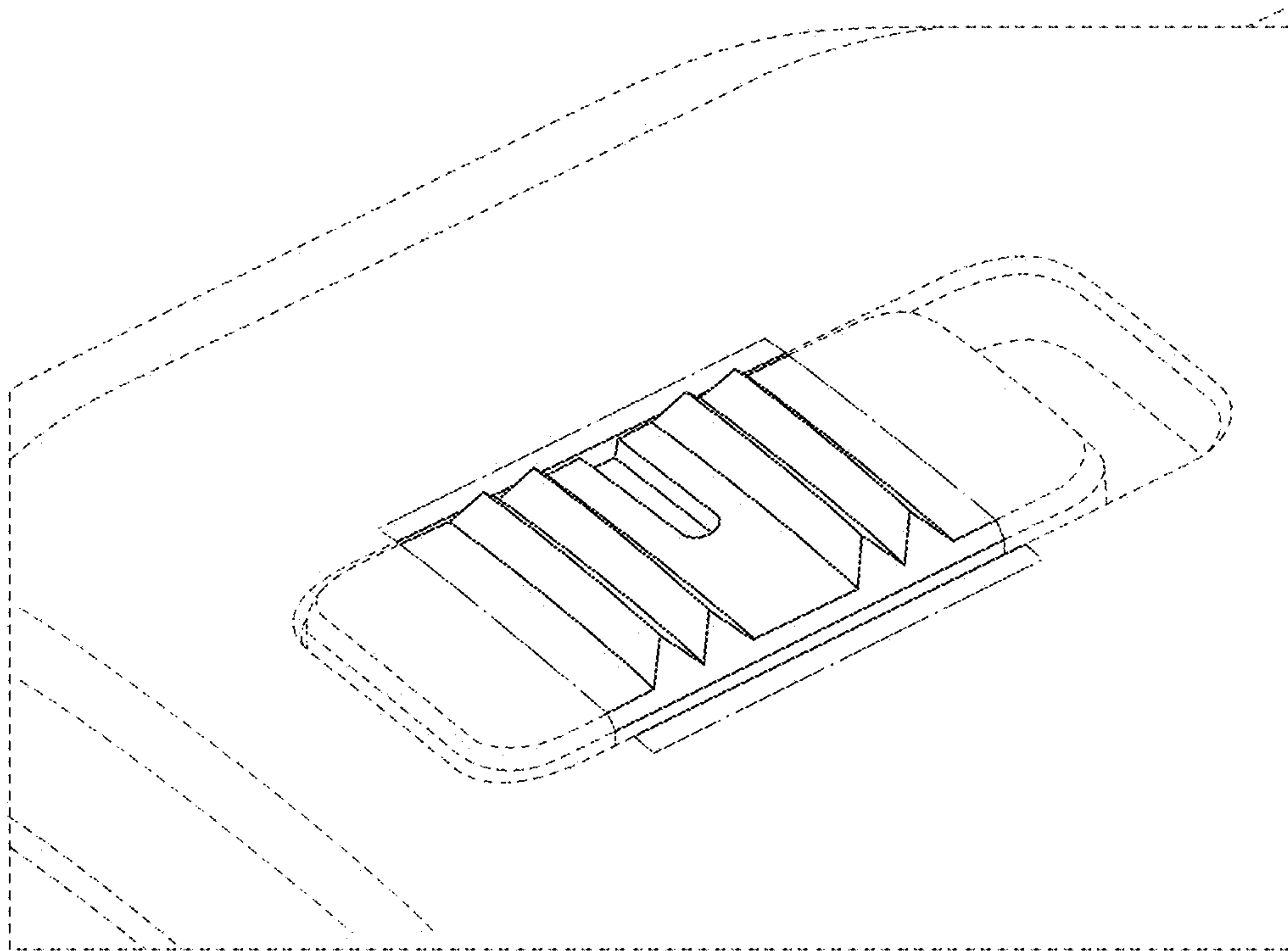

FIG. 9

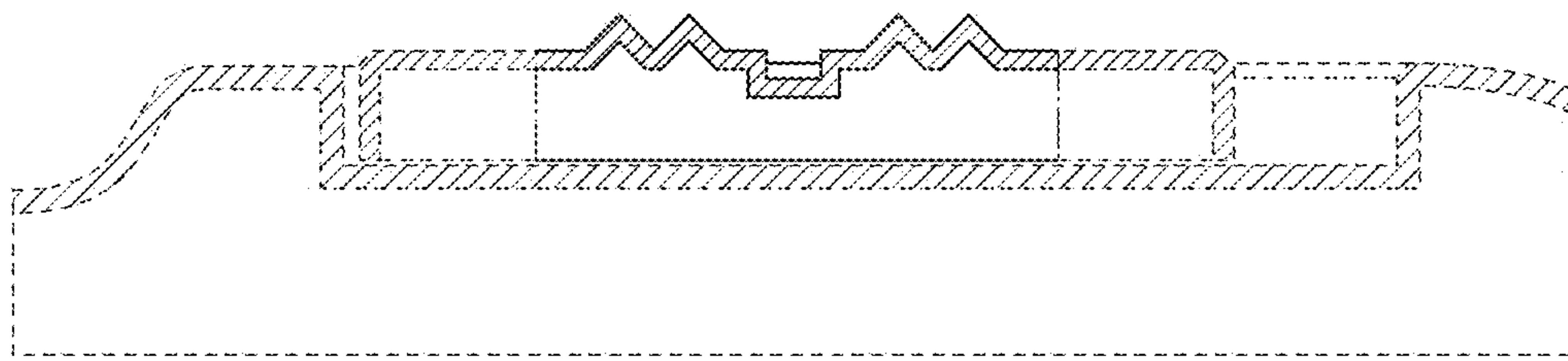

FIG. 10