

US00D963535S

(12) **United States Design Patent** (10) **Patent No.:** **US D963,535 S**
Stegawski et al. (45) **Date of Patent:** **** Sep. 13, 2022**

(54) **SPLIT FENDER**

(71) Applicant: **PACCAR Inc**, Bellevue, WA (US)
(72) Inventors: **Piotr Stegawski**, Bellevue, WA (US);
Jonathan Duncan, Bellevue, WA (US);
Peter Vurpillat, Bellevue, WA (US);
Steve Hovind, Bellevue, WA (US);
Amanda Koh, Bellevue, WA (US);
Brian Hannon, Bellevue, WA (US)
(73) Assignee: **PACCAR Inc**, Bellevue, WA (US)

(**) Term: **15 Years**

(21) Appl. No.: **29/760,076**

(22) Filed: **Nov. 29, 2020**

(51) **LOC (13) Cl.** **12-16**

(52) **U.S. Cl.**
USPC **D12/181**

(58) **Field of Classification Search**
USPC D12/181–184, 190, 191, 400
CPC B62D 35/00; B62D 35/007; B62D 37/02
See application file for complete search history.

(56) **References Cited**

U.S. PATENT DOCUMENTS

D643,352 S *	8/2011	Hjorten	D12/181
D697,846 S *	1/2014	Conway	D12/184
D786,753 S *	5/2017	Conway	D12/184
D786,754 S *	5/2017	Conway	D12/184
D788,661 S *	6/2017	Henstridge	D12/184
D818,910 S *	5/2018	Yates	D12/181
D820,750 S *	6/2018	Hallgren	D12/184
D822,565 S *	7/2018	Hallgren	D12/184
D863,172 S *	10/2019	Duncan	F01N 13/20
				D12/196
D890,657 S *	7/2020	Reeves	D12/184
D902,102 S *	11/2020	Duncan	D12/196
D906,902 S *	1/2021	Duncan	D12/163
D942,340 S *	2/2022	Hallgren	D12/184

OTHER PUBLICATIONS

“T800,” Kenworth Truck Company, 2002, 32-page brochure.
“T800,” Kenworth Truck Company, 2003, 32-page brochure.
“T800,” Kenworth Truck Company, 2005, 28-page brochure.

(Continued)

Primary Examiner — Katrina A Betton

(74) *Attorney, Agent, or Firm* — Seed IP Law Group LLP

(57) **CLAIM**

The ornamental design for a split fender, as shown and described.

DESCRIPTION

FIG. 1 is an isometric view of a split fender, showing an embodiment of our new design.

FIG. 2 is a front elevational view thereof.

FIG. 3 is a rear elevational view thereof.

FIG. 4 is a left side elevational view thereof.

FIG. 5 is a right side elevational view thereof.

FIG. 6 is a top plan view thereof.

FIG. 7 is a bottom plan view thereof.

FIG. 8 is an isometric view of a split fender, showing another embodiment of our new design, which is a mirror image of the split fender shown in FIGS. 1-7.

FIG. 9 is a front elevational view thereof.

FIG. 10 is a rear elevational view thereof.

FIG. 11 is a right side elevational view thereof.

FIG. 12 is a left side elevational view thereof.

FIG. 13 is a top plan view thereof; and,

FIG. 14 is a bottom plan view thereof.

Stippling in the drawings represent the three-dimensional contours of the design, and is not intended to indicate surface decoration. The broken lines shown in the drawings depict portions of the split fender that form no part of the claimed design.

1 Claim, 14 Drawing Sheets

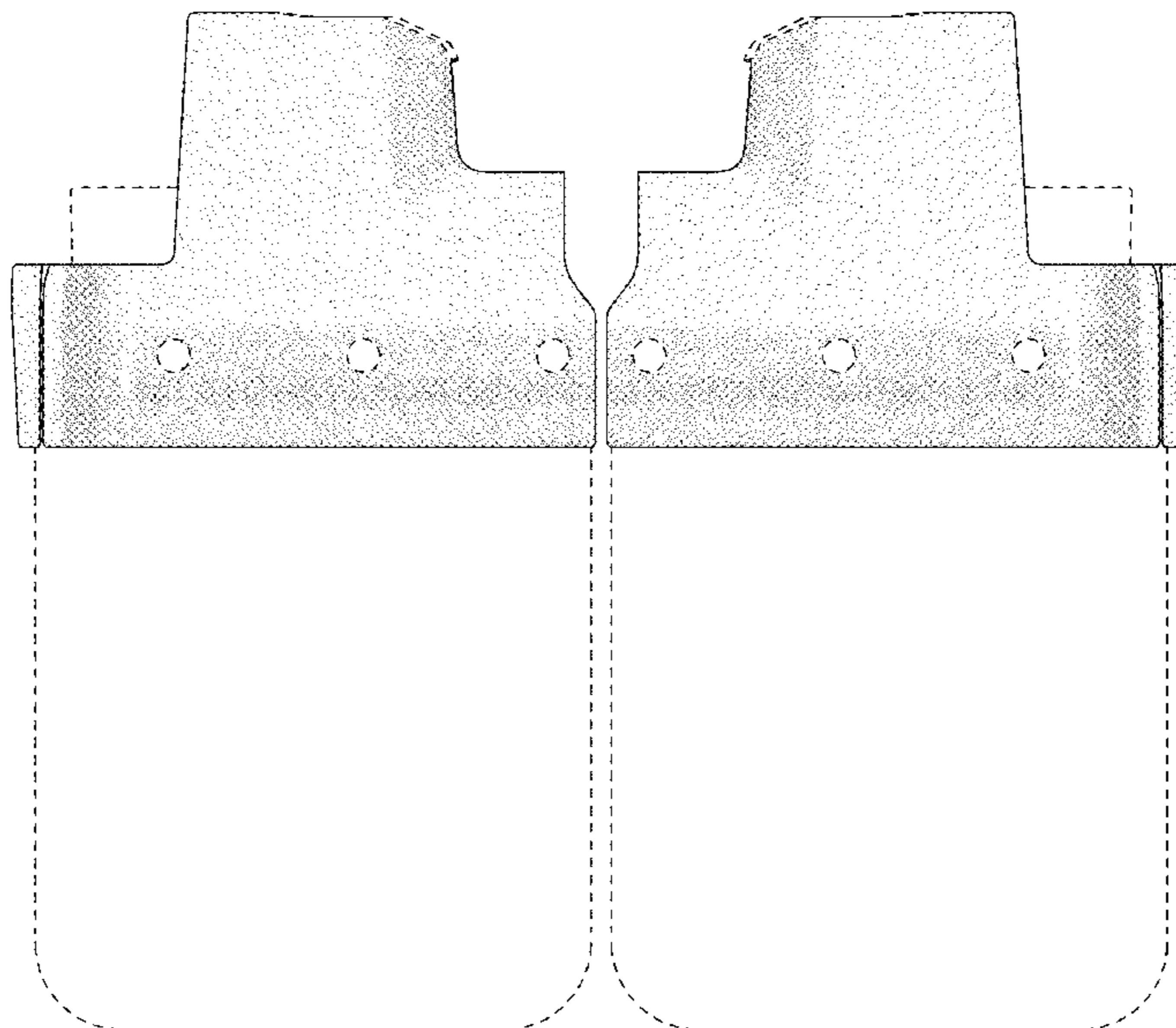

(56)

References Cited

OTHER PUBLICATIONS

- “T800,” Kenworth Truck Company, 2009, 28-page brochure.
 “T800B,” Kenworth Truck Company, 1993, 8-page brochure.
 Peterbilt Motors Company, “The Working Class,” Sep. 1976, 6-page brochure.
 “The World’s Best,” Kenworth Truck Company, 1992, 12-page brochure.
 “W900,” Kenworth Truck Company, 1996, 7-page brochure.
 “W900,” Kenworth Truck Company, 2002, 32-page brochure.
 “W900,” Kenworth Truck Company, 2005, 28-page brochure.
 “W900,” Kenworth Truck Company, 2009, 28-page brochure.
 Kenworth Truck Company, “W900L AeroCab,” 1994, 2-page brochure.
 Kenworth Truck Company, “AeroCab,” 1993, 5-page brochure.
 “AeroCab,” Kenworth Truck Company, as early as 1995, 3-page brochure.
 “C500B,” Kenworth Truck Company, as early as 1990, 4-page brochure.
 Peterbilt Motors Company, “Class Pays, Medium Duty,” Sep. 2000, 12-page brochure.
 “Class Pays, Truck Models,” Peterbilt Motors Company, Mar. 2005, 24-page brochure.
 “Class Pays,” Peterbilt Motors Company, Nov. 1998, 10-page brochure.
 Peterbilt Motors Company, “Class Pays,” Sep. 1997, 10-page brochure.
 “Class Pays, Construction Trucks,” Peterbilt Motors Company, Nov. 2003, 16-page brochure.
 “Kenworth Truck Models,” Kenworth Truck Company, 2010, 16-page brochure.
 Peterbilt Motors Company, “Model 330,” Oct. 1997, 3-page brochure.
 Peterbilt Motors Company, “Model 379,” Apr. 2005, 2-page brochure.
 Peterbilt Motors Company, “Model 379,” Mar. 1996, 5-page brochure.
 Peterbilt Motors Company, “Rest with Class,” Apr. 1978, 4-page brochure.
 “T170 Class 5,” Kenworth Truck Company, 2008, 4-page brochure.
 “T270 Class 6 and T370 Class 7,” Kenworth Truck Company, 2008, 6-page brochure.
 “T270 Class 6 and T370 Class 7,” Kenworth Truck Company, 2009, 6-page brochure.
 “T270 Class 6 and T370 Class 7 Hybrid,” Kenworth Truck Company, 2009, 6-page brochure.
 “T680,” Kenworth Truck Company, 2013, 34-page brochure.
 “T680,” Kenworth Truck Company, 2016, 34-page brochure.
 “T880,” Kenworth Truck Company, 2017, 32-page brochure.
 “Model 579,” Peterbilt Motors Company, Oct. 2013, 13-page brochure.
 “Medium Duty,” Peterbilt Motors Company, 2013, 9-page brochure.
 “On-Highway,” Peterbilt Motors Company, 2013, 13-page brochure.
 “Vocational,” Peterbilt Motors Company, 2013, 11-page brochure.
 “T440,” Kenworth Truck Company, 2010, 6-page brochure.
 “T470,” Kenworth Truck Company, 2010, 6-page brochure.
 “T470H,” Kenworth Truck Company, 2009, 2-page brochure.
 “Model 220,” Peterbilt Motors Company, 2019, 2-page brochure.
 “220EV,” Peterbilt Motors Company, 2020, 5-page brochure.
 “Model 337,” Peterbilt Motors Company, 2020, 2-page brochure.
 “Model 389,” Peterbilt Motors Company, 2019, 2-page brochure.
 “Model 348,” Peterbilt Motors Company, 2019, 2-page brochure.
 “Model 520,” Peterbilt Motors Company, 2019, 2-page brochure.
 “Model 567,” Peterbilt Motors Company, 2020, 16-page brochure.
 “567 Heritage,” Peterbilt Motors Company, 2017, 2-page brochure.
 “Model 579,” Peterbilt Motors Company, 2019, 28-page brochure.
 “C500,” Kenworth Truck Company, 2012, 2-page brochure.
 “T680,” Kenworth Truck Company, 2019, 40-page brochure.
 “T800,” Kenworth Truck Company, 2012, 28-page brochure.
 “T440/T470,” Kenworth Truck Company, 2015, 8-page brochure.
 “K270E/K370E,” Kenworth Truck Company, 2020, 4-page brochure.
 “T170/T270/T370,” Kenworth Truck Company, 2019, 16-page brochure.
 “K270/K370,” Kenworth Truck Company, 2014, 12-page brochure.
 “W990,” Kenworth Truck Company, 2018, 32-page brochure.
 “T880,” Kenworth Truck Company, 2019, 36-page brochure.
 “Model 367,” Peterbilt Motors Company, <https://www.peterbilt.com/trucks/vocational/model-367>, retrieved Nov. 20, 2020, 12 pages.
 “Model 365,” Peterbilt Motors Company, <https://www.peterbilt.com/trucks/vocational/model-365>, retrieved Nov. 20, 2020, 11 pages.
 “Model 325,” Peterbilt Motors Company, <https://www.peterbilt.com/trucks/medium-duty/model-325>, retrieved Nov. 20, 2020, 12 pages.

* cited by examiner

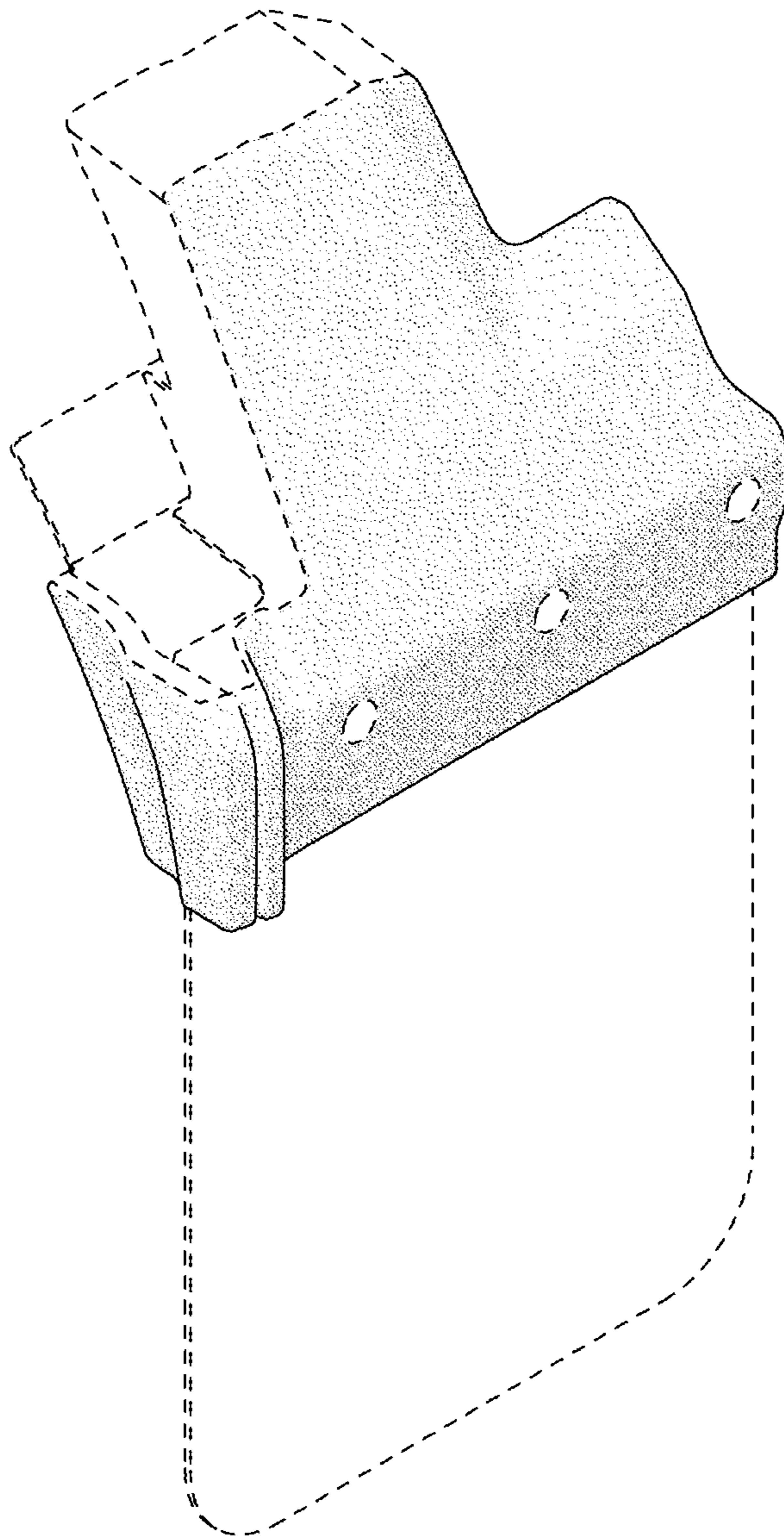

FIG. 1

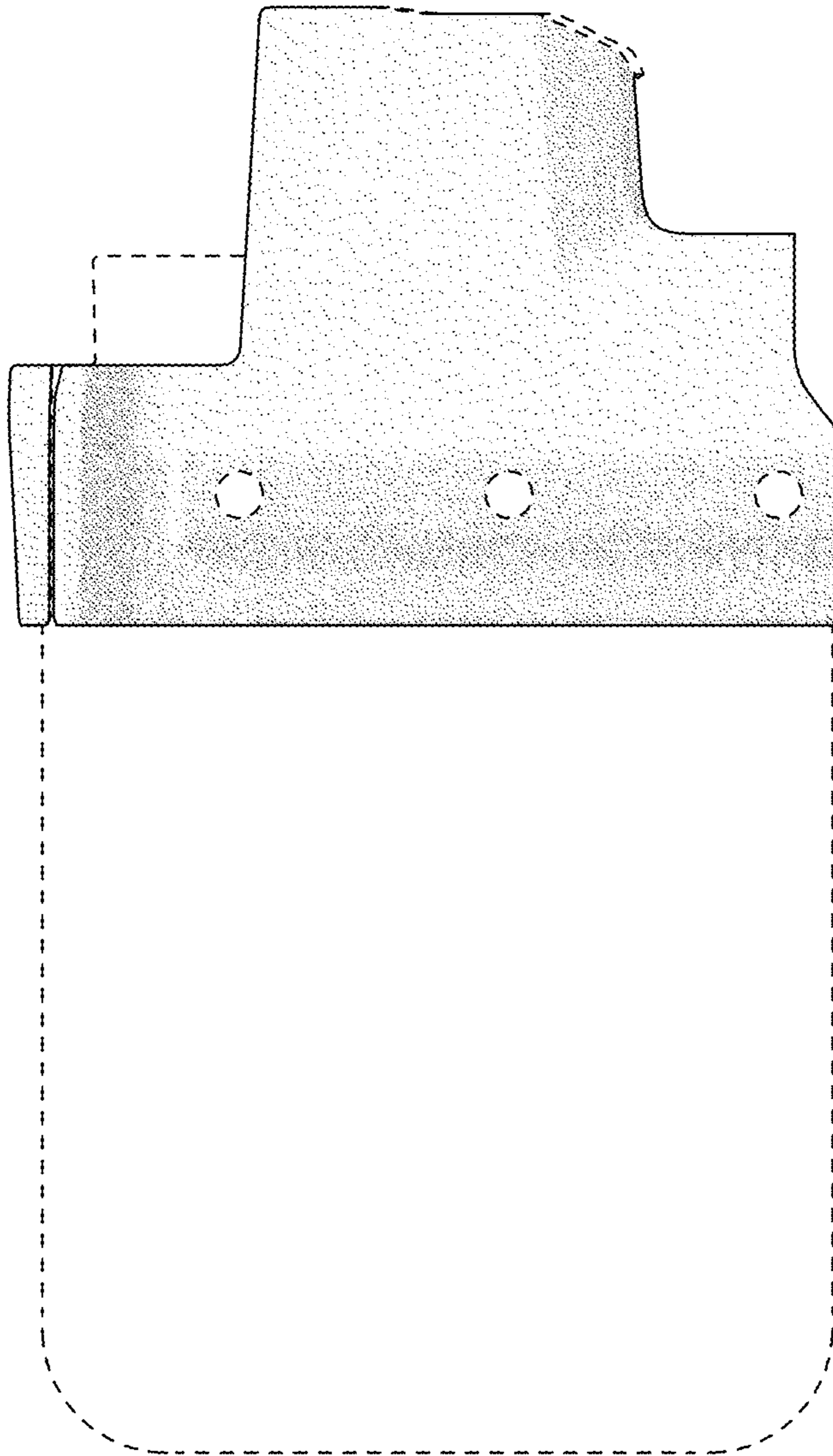

FIG. 2

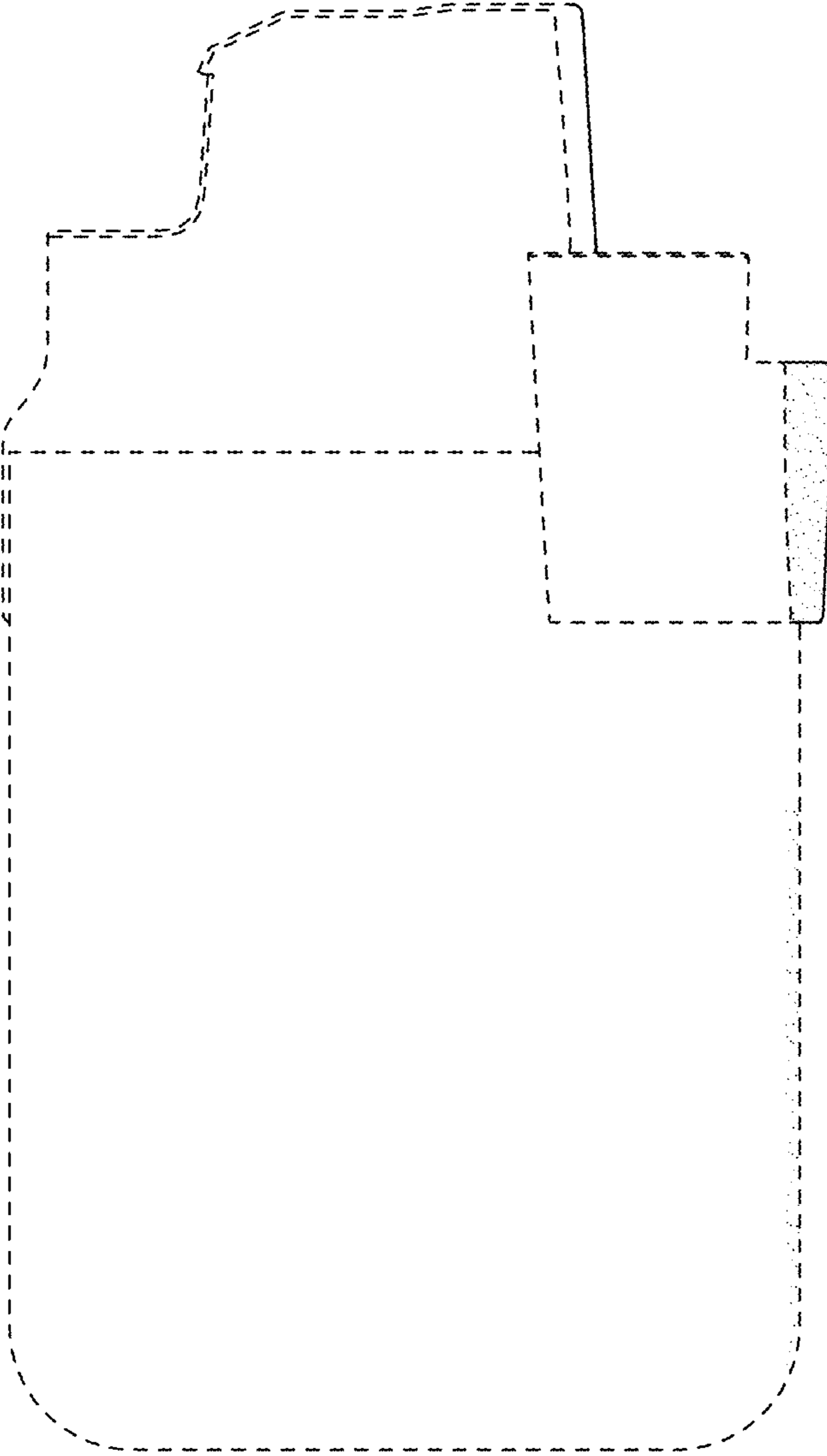

FIG. 3

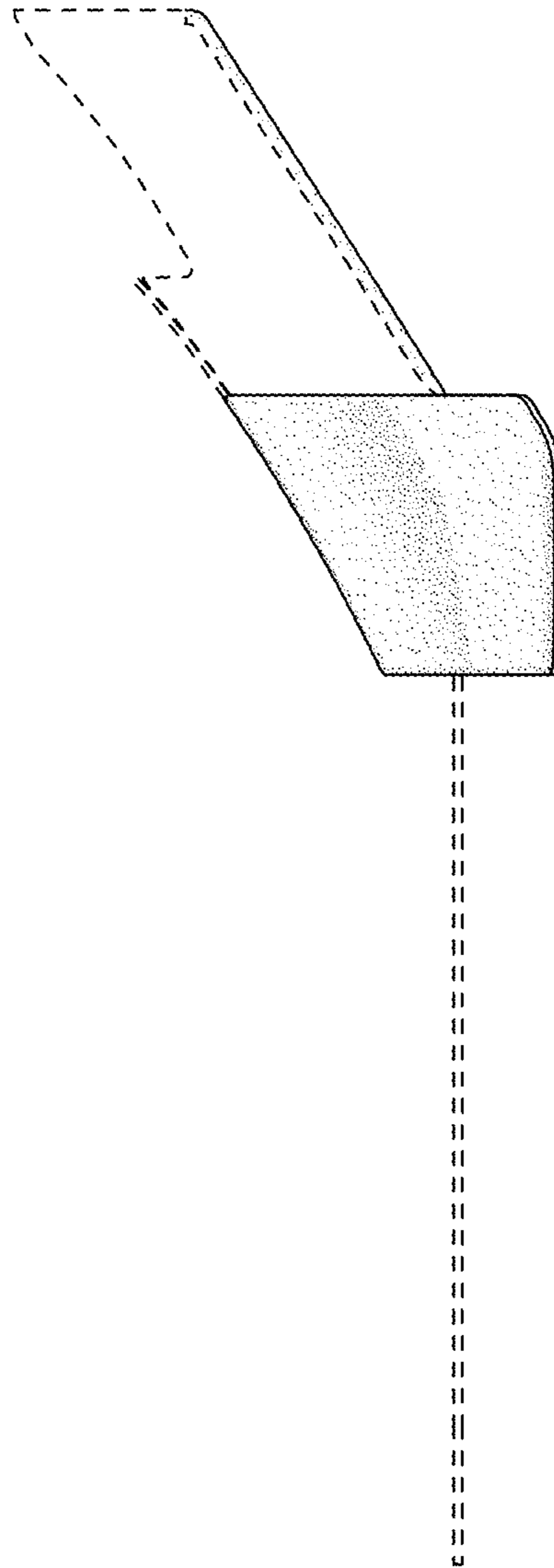

FIG. 4

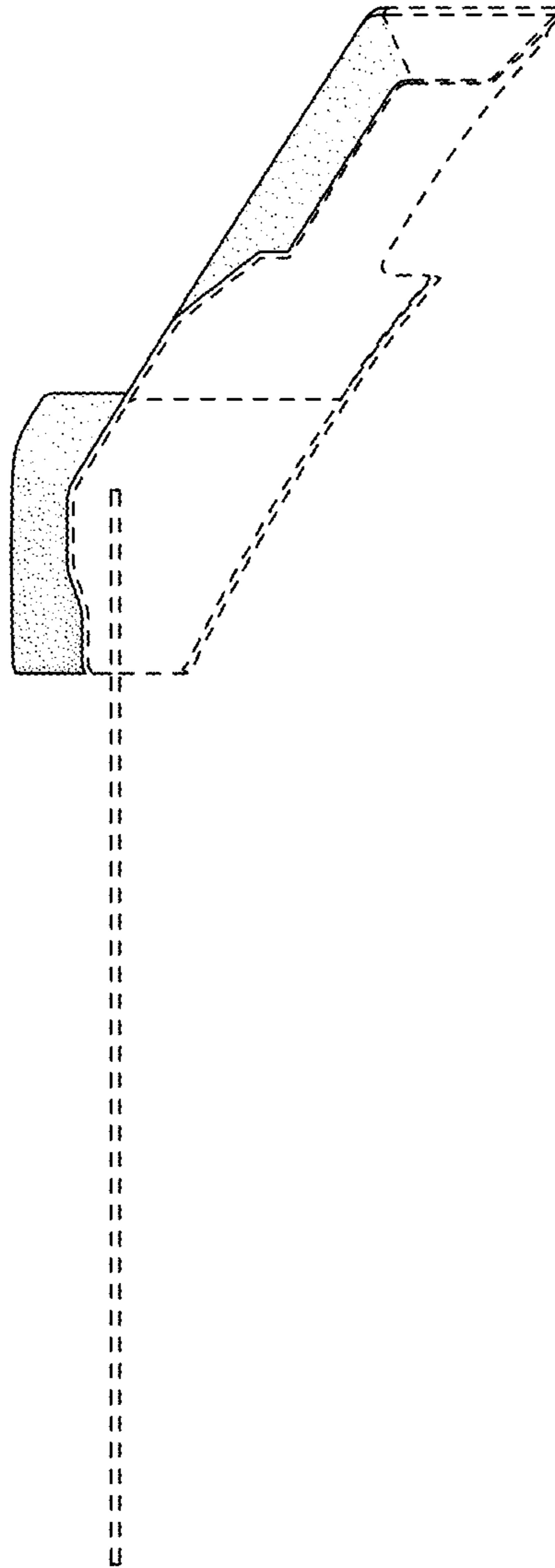

FIG. 5

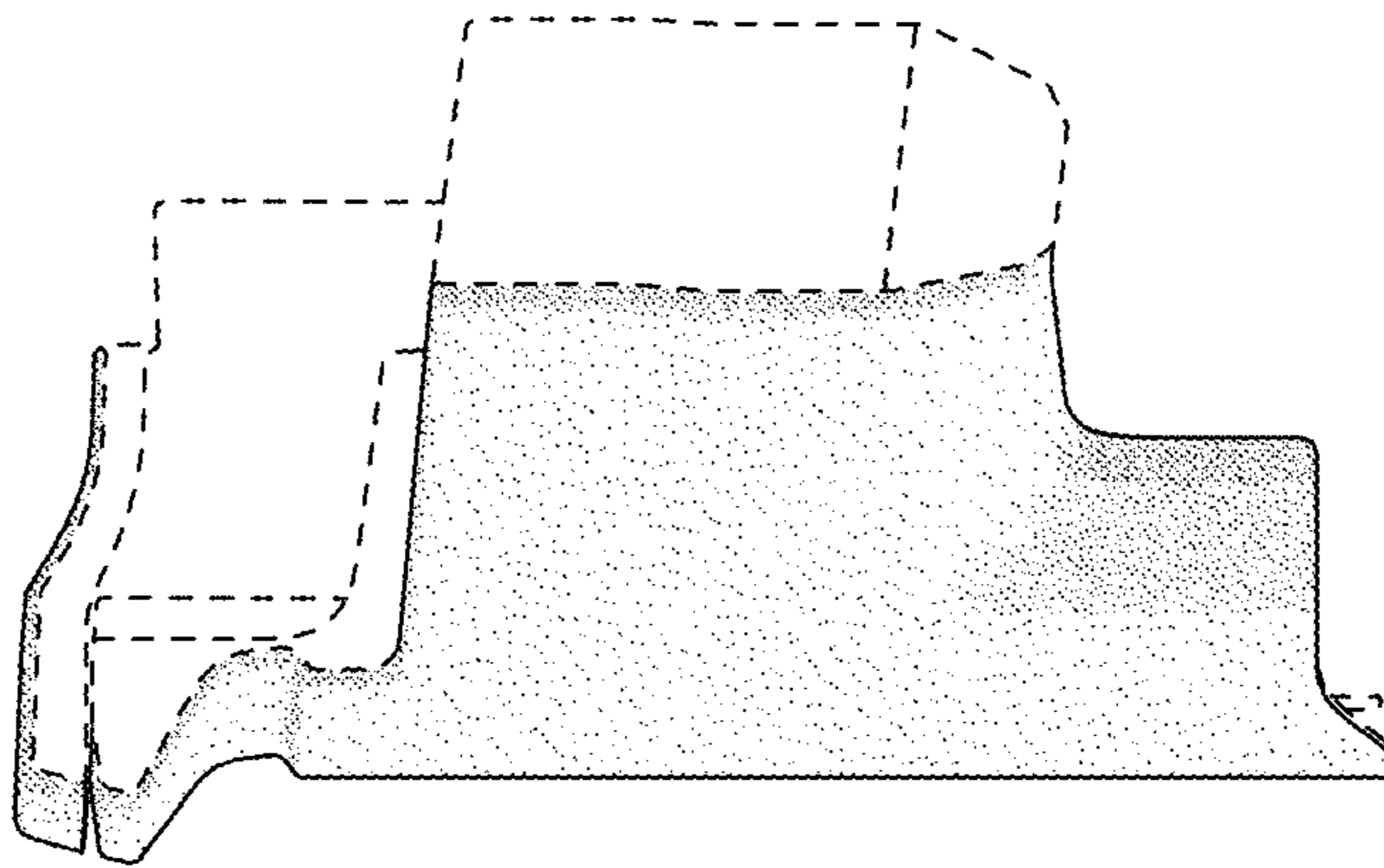

FIG. 6

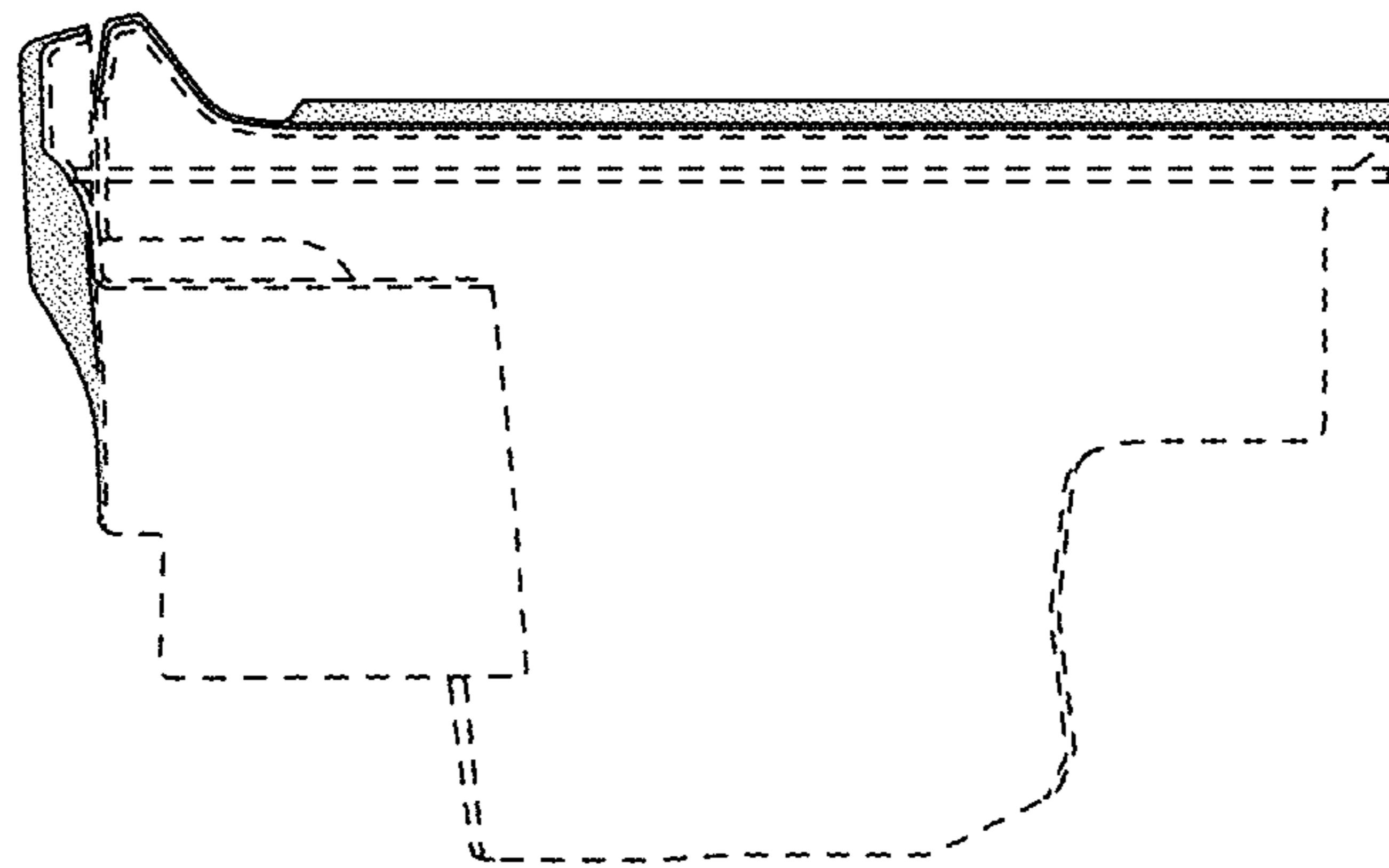

FIG. 7

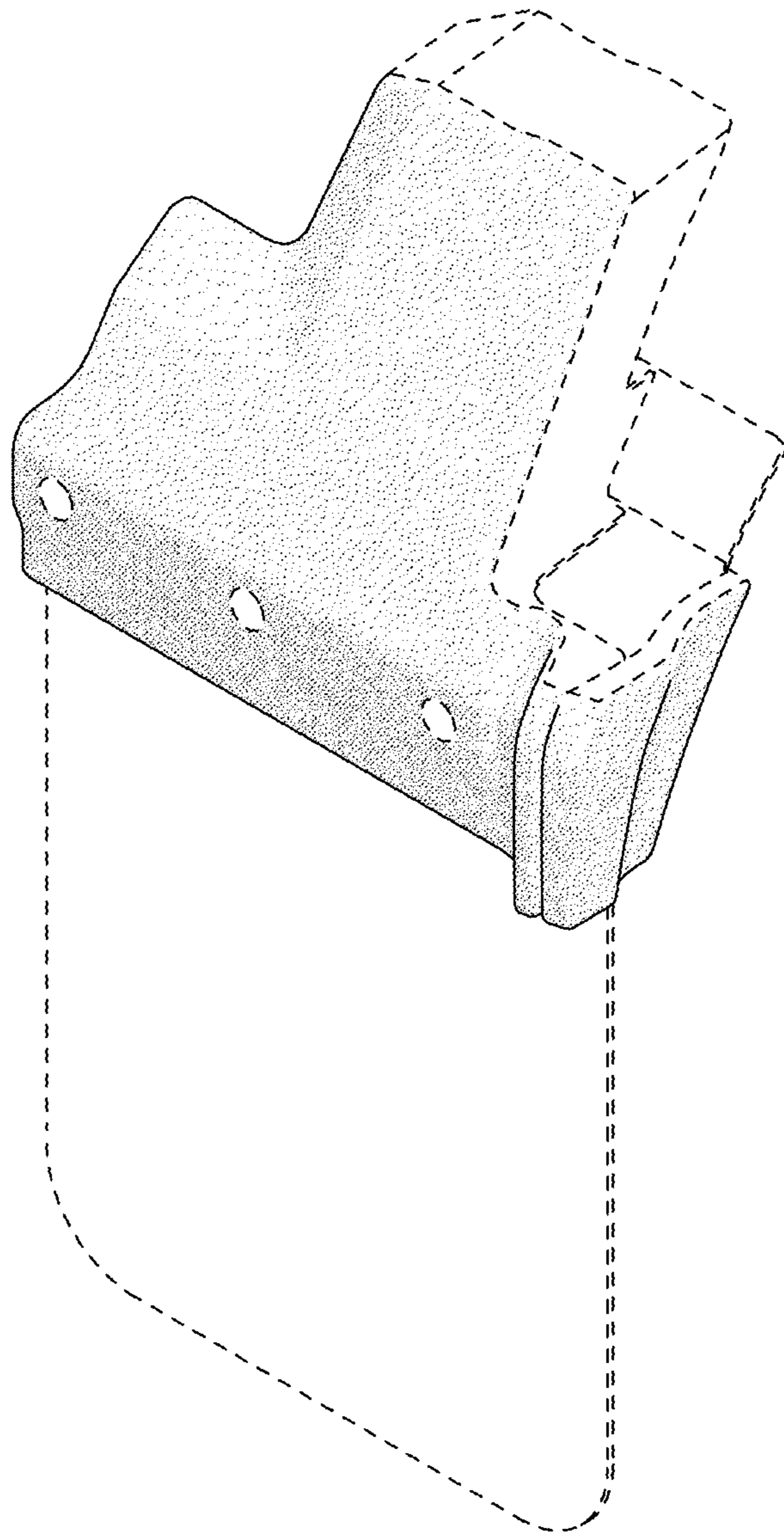

FIG. 8

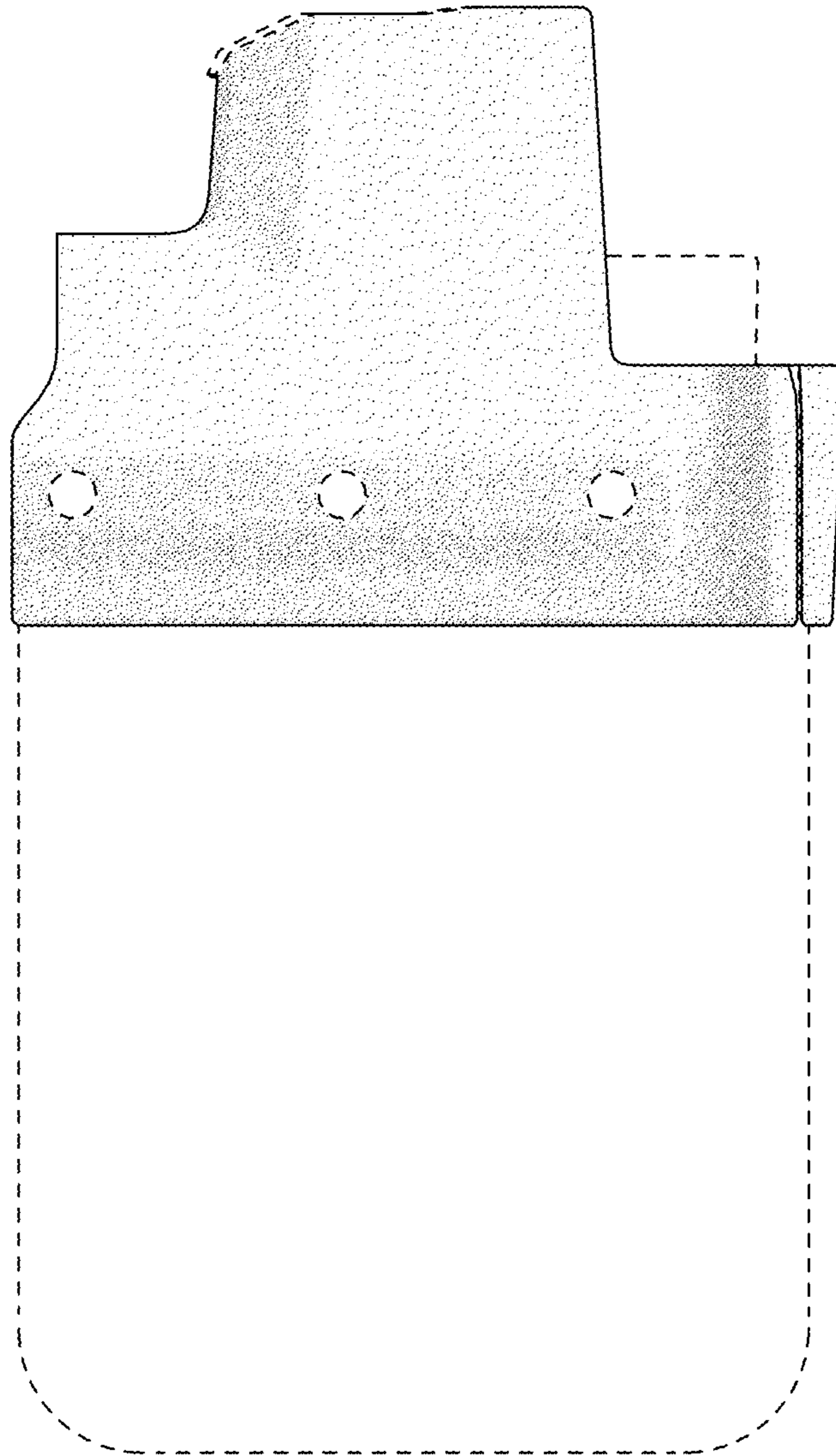

FIG. 9

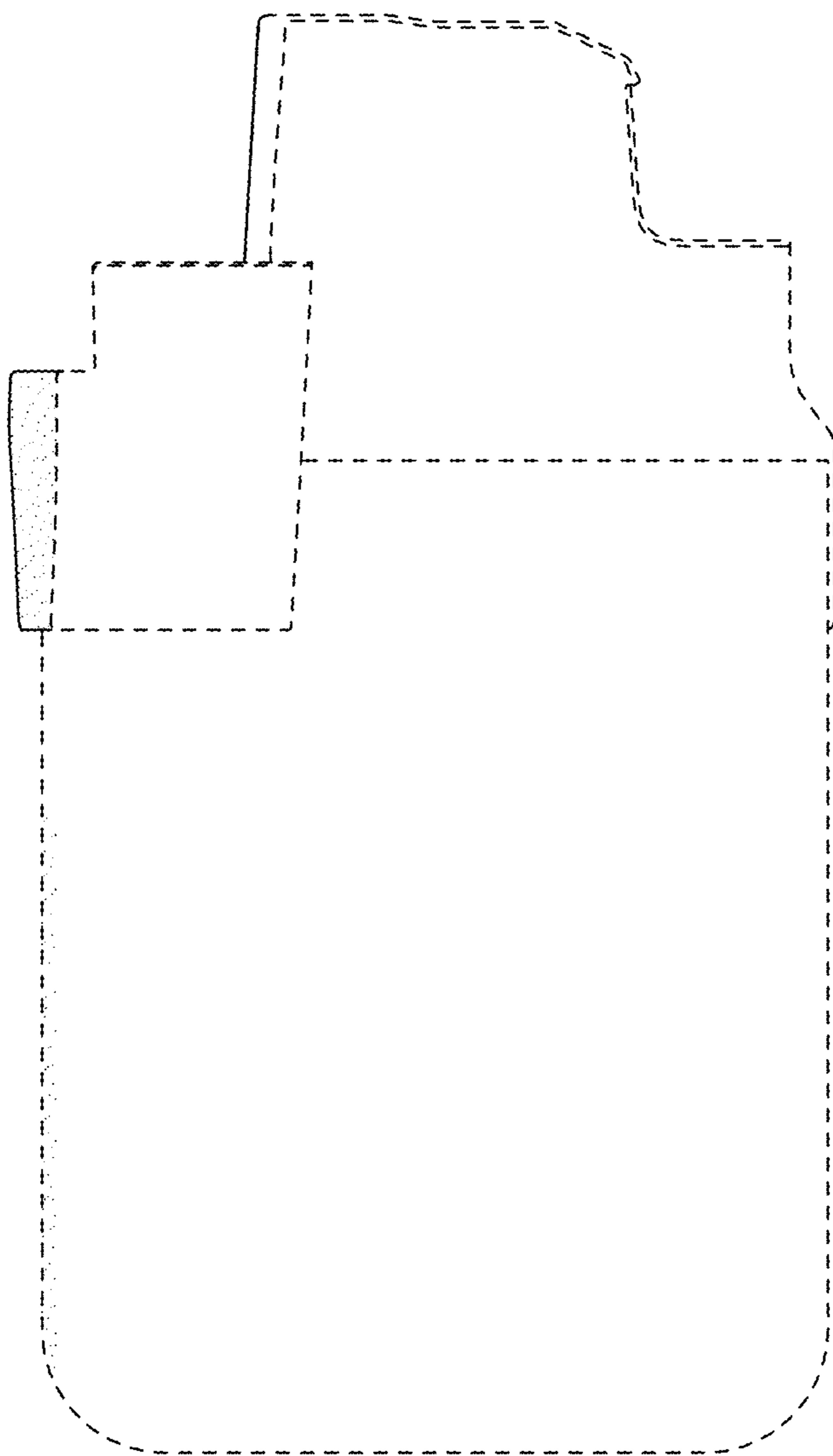

FIG. 10

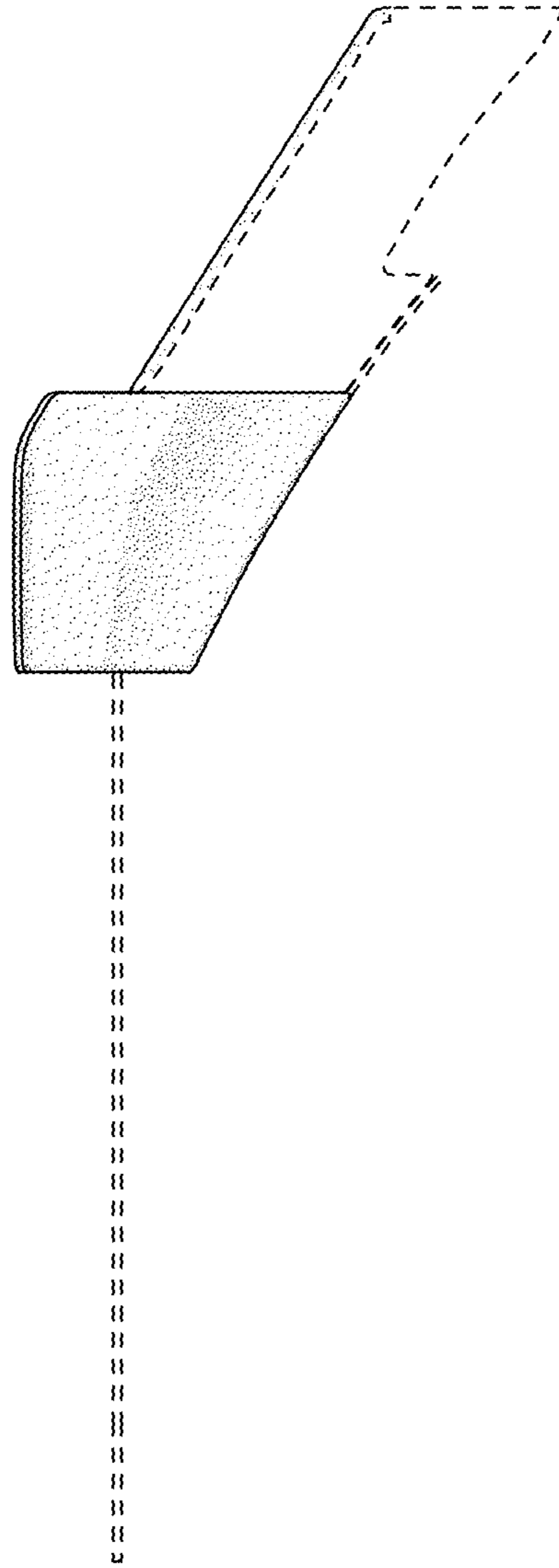

FIG. 11

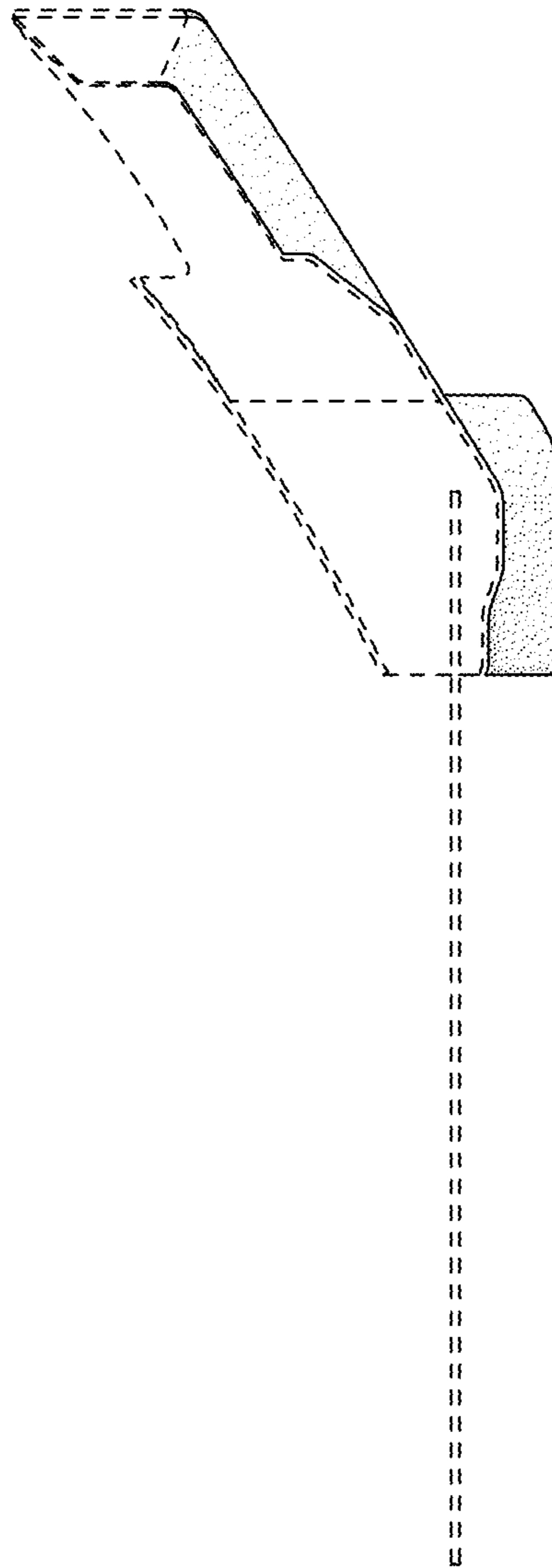

FIG. 12

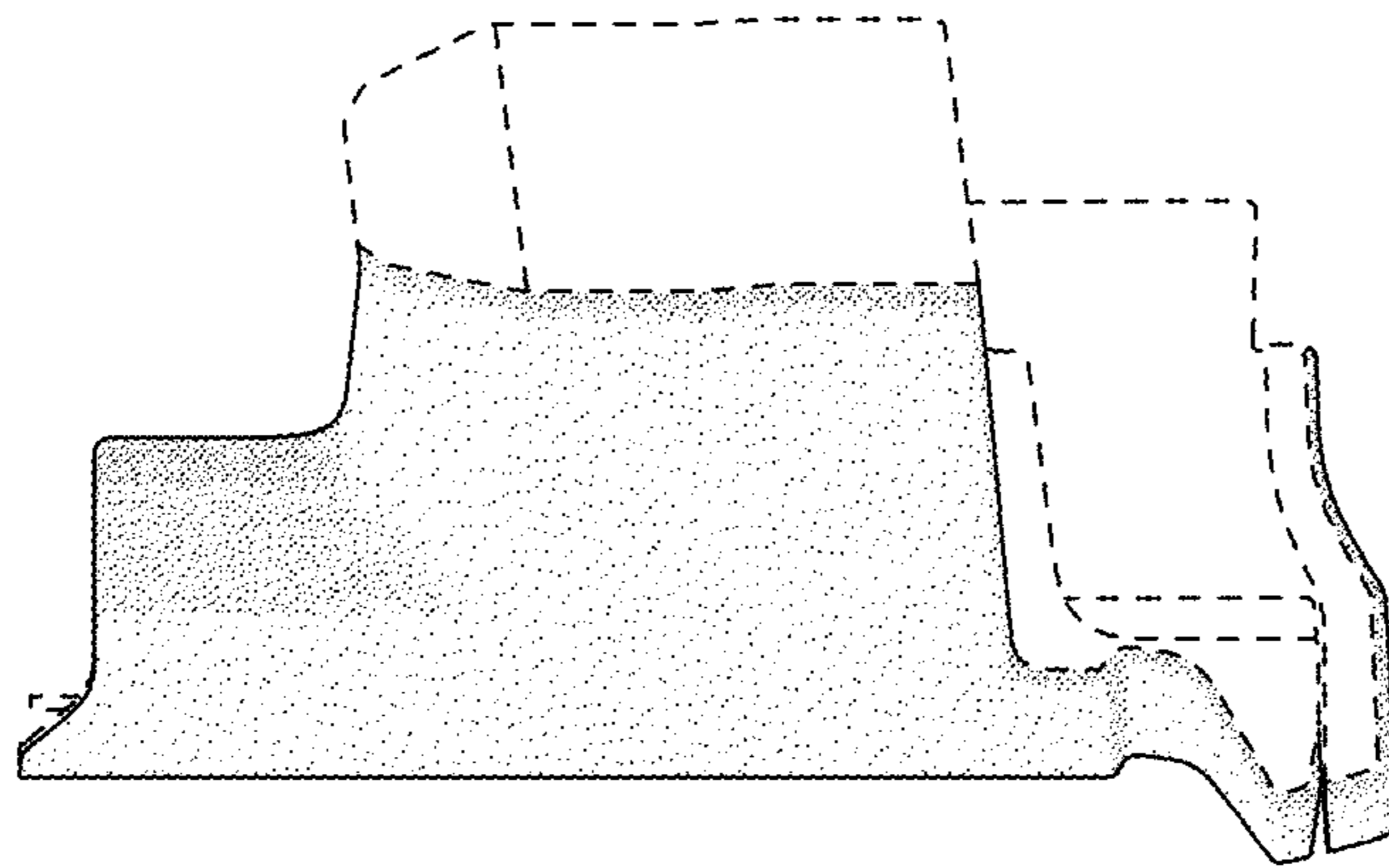

FIG. 13

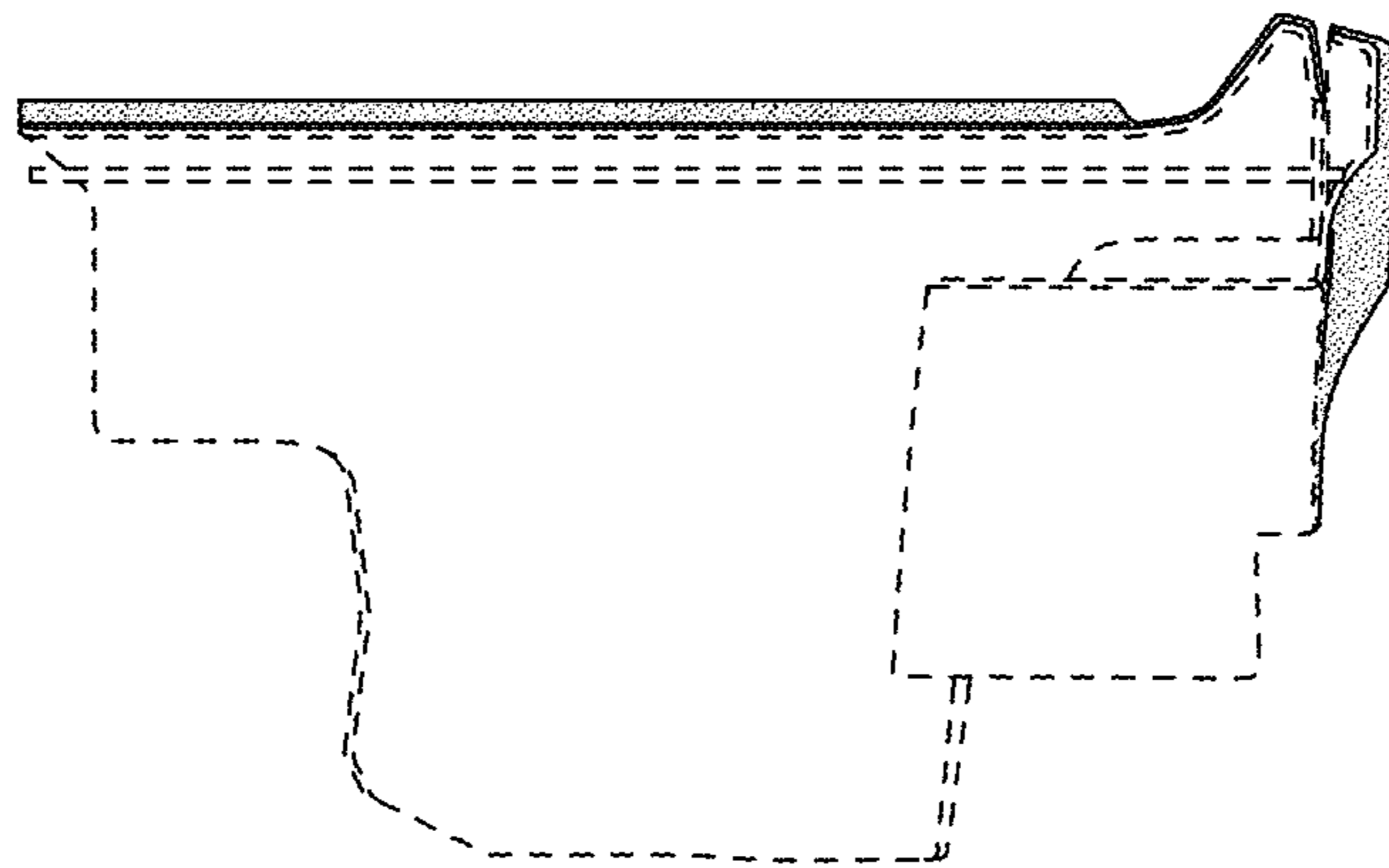

FIG. 14