



US00D963527S

(12) **United States Design Patent** (10) **Patent No.:** **US D963,527 S**
Larson (45) **Date of Patent:** **** Sep. 13, 2022**

(54) **CENTER SEGMENT OF A MOTOR VEHICLE, TOY AND/OR REPLICA**
(71) Applicant: **Dr. Ing. h.c. F. Porsche Aktiengesellschaft, Stuttgart (DE)**
(72) Inventor: **Grant Larson, Illingen (DE)**
(73) Assignee: **Dr. Ing. h.c. F. Porsche Aktiengesellschaft**

D497,860 S 11/2004 Hoelzel et al.
D539,191 S * 3/2007 Castiglione D12/92
D552,514 S * 10/2007 Castiglione D12/92
D566,022 S 4/2008 Johnson
D587,980 S 3/2009 Rosenbohm
D597,011 S 7/2009 Habib
D598,355 S 8/2009 Sato et al.
D600,181 S 9/2009 Larson
D600,183 S 9/2009 Habib
(Continued)

(**) Term: **15 Years**
(21) Appl. No.: **29/801,914**
(22) Filed: **Aug. 2, 2021**

Related U.S. Application Data

(62) Division of application No. 29/700,817, filed on Aug. 6, 2019, now Pat. No. Des. 930,520.

Foreign Application Priority Data

Feb. 18, 2019 (DE) 402019100198.0

(51) **LOC (13) Cl.** **12-16**

(52) **U.S. Cl.**
USPC **D12/164**

(58) **Field of Classification Search**
USPC D12/86, 90-92, 164; D21/433, 434, D21/531-535
CPC B62D 25/00; B62D 25/06; B62D 33/00; B62D 35/00
See application file for complete search history.

(56) **References Cited**

U.S. PATENT DOCUMENTS

D422,252 S 4/2000 Sacco et al.
6,293,362 B1 9/2001 Sasaki et al.
D495,631 S 9/2004 Metros et al.
D496,611 S 9/2004 Kneefel et al.

OTHER PUBLICATIONS

Car Bodies. (Design—© Questel) orbit.com. [Online PDF compilation of references] 32 pgs. Print Dates Range Aug. 31, 2020-Sep. 30, 2020 [Retrieved Mar. 23, 2022].*

(Continued)

Primary Examiner — George D. Kirschbaum

Assistant Examiner — Suzanne E Tisdell

(74) *Attorney, Agent, or Firm* — RatnerPrestia

(57) **CLAIM**

The ornamental design for a center segment of a motor vehicle, toy and/or replica, as shown and described.

DESCRIPTION

FIG. 1 is a front right perspective view of a center segment of a motor vehicle, toy and/or replica according to my new design;

FIG. 2 is a front elevation view thereof;

FIG. 3 is a rear elevation view thereof;

FIG. 4 is an elevation view from the right side thereof;

FIG. 5 is an elevation view from the left side thereof; and,

FIG. 6 is a top plan view thereof.

Evenly-spaced broken lines show portions of the center segment of a motor vehicle, toy and/or replica. Dot-dash pattern broken lines show unclaimed environmental subject matter.

1 Claim, 4 Drawing Sheets

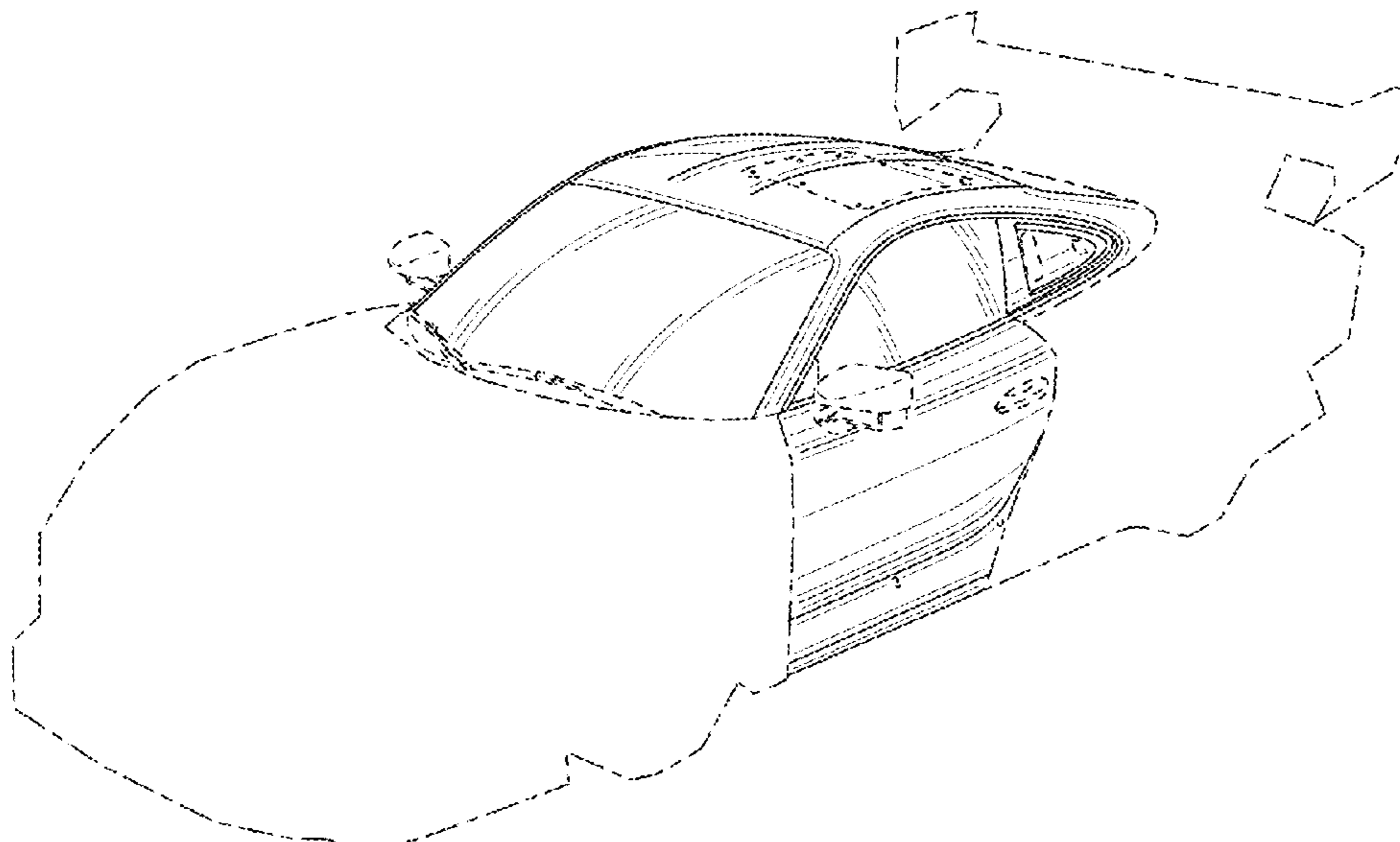

(56)

References Cited

U.S. PATENT DOCUMENTS

D600,185 S 9/2009 Habib
 D607,390 S 1/2010 Krauss
 D628,938 S * 12/2010 Yamazaki D12/91
 D631,807 S 2/2011 Clottu
 D644,584 S 9/2011 Vardis
 D659,059 S 5/2012 Elmitt
 D663,240 S 7/2012 Scheinhutte
 D664,474 S * 7/2012 Stoschek D12/92
 D669,001 S 10/2012 Varga
 D684,896 S 6/2013 Scheinhütte
 D701,146 S 3/2014 Varga
 D704,099 S 5/2014 Varga
 D705,131 S 5/2014 Larson
 D716,697 S * 11/2014 Stoschek D12/92
 D718,686 S 12/2014 Hammoud et al.
 D731,929 S 6/2015 Schramm
 D733,614 S 7/2015 Scheinhutte
 D749,985 S * 2/2016 Kozub D12/92
 D753,023 S 4/2016 Villevoye
 D763,152 S 8/2016 Frascella
 D767,449 S * 9/2016 Pevovar D12/92
 D774,421 S 12/2016 Larson
 9,517,803 B2 12/2016 Handzel, Jr.
 D777,620 S 1/2017 Pevovar et al.
 D779,399 S 2/2017 Bucher et al.
 D787,387 S 5/2017 Curic et al.
 D787,389 S 5/2017 Wolff et al.
 D790,415 S 6/2017 Woolley
 9,714,058 B2 7/2017 Fahland et al.
 D796,404 S 9/2017 Nurnberger
 D797,607 S 9/2017 Preuninger et al.
 D804,356 S * 12/2017 Cho D12/91
 D805,436 S 12/2017 Yamashita et al.
 D808,310 S 1/2018 Zavatski et al.
 D808,311 S 1/2018 Piscitelli et al.
 D808,862 S 1/2018 Ujhasi
 D809,971 S * 2/2018 Lee D12/92
 D811,300 S 2/2018 Yamashita et al.
 D813,121 S 3/2018 Swanseger
 D823,727 S 7/2018 Hauser
 D824,288 S 7/2018 Hauser
 D826,784 S 8/2018 Hauser
 D833,331 S 11/2018 Yamashita
 10,118,539 B2 11/2018 Erb et al.
 D835,730 S 12/2018 Chung et al.
 D839,786 S 2/2019 Baum et al.
 D842,759 S 3/2019 Baum et al.
 D862,288 S 10/2019 Baum et al.
 D867,241 S 11/2019 Schmölz
 D868,631 S 12/2019 Larson
 D870,005 S 12/2019 Yamashita
 D870,596 S 12/2019 Yamashita
 D875,020 S 2/2020 Donfrancesco et al.
 10,604,198 B2 3/2020 Escoffier et al.
 D880,359 S 4/2020 Baum et al.
 D881,091 S 4/2020 Smith
 D883,145 S 5/2020 Baum
 D883,146 S 5/2020 Baum
 D885,258 S 5/2020 Larson
 D887,900 S 6/2020 Stopka
 D887,925 S 6/2020 Metros et al.
 D891,300 S * 7/2020 Borkert D12/88
 D897,249 S 9/2020 Baum
 D897,250 S 9/2020 Larson
 D897,251 S 9/2020 Stopka
 D897,903 S 10/2020 Scholz
 D898,639 S 10/2020 Baum

D901,346 S 11/2020 Burki
 D906,912 S 1/2021 Anscheidt et al.
 D907,547 S 1/2021 Buck et al.
 D929,277 S 8/2021 Chan et al.
 D930,522 S 9/2021 Hunwick
 D931,161 S 9/2021 Forrest
 D932,407 S 10/2021 Wu
 D932,955 S 10/2021 Peat
 D932,957 S 10/2021 Schmölz
 D934,129 S 10/2021 Bernardi
 D938,820 S 12/2021 Sanders et al.
 D938,866 S 12/2021 Theis
 D938,867 S 12/2021 Becker
 D939,401 S 12/2021 Becker
 D941,716 S 1/2022 Kim et al.
 D942,327 S * 2/2022 Crijns D12/88
 D943,477 S 2/2022 Chen
 D945,924 S * 3/2022 Borkert D12/88
 D945,926 S * 3/2022 Borkert D12/88
 2002/0033294 A1 3/2002 Ishizaki et al.
 2005/0211484 A1 9/2005 Ellerman
 2007/0102219 A1 5/2007 Park
 2008/0185871 A1 8/2008 Ishiyama et al.
 2013/0270870 A1 10/2013 O'Brien
 2017/0232926 A1 8/2017 Barbat et al.
 2017/0355400 A1 12/2017 Weston

OTHER PUBLICATIONS

Seabaugh, Christian. 2022 Porsche 911 GT3 First Drive. Apr. 20, 2021. Motortrend. <https://www.motortrend.com/reviews/2022-porsche-911-gt3-first-drive-review/>.
 Iger, Bradley. 2022 Porsche 911 GT3 First Drive Review. Apr. 20, 2021. Motor 1. <https://www.motor1.com/reviews/502322/2022-porsche-911-gt3-first-drive/>.
 Catchpole, Henry. New Porsche 911 GT3 2021 review. Apr. 20, 2021. Auto Express. <https://www.autoexpress.co.uk/porsche/911/353723/new-porsche-911-gt3-2021-review/>.
 Entire patent prosecution history of U.S. Appl. No. 29/700,817, filed Aug. 6, 2019 entitled "Portions of Motor Vehicle, Toy and/or Replica."
 Capparella, "Porsche Brings Back Iconic 935 Name for a New Race Car", Car and Driver, <https://www.caranddriver.com/news/a23496085/porsche-935-race-car-rennsport>, 2018, 6 pages.
 Silvestro et al "Porsche Just Brought Back the 935 Moby Dick With This GT2 RS-Based Monster", Road and Track, <https://www.roadandtrack.com/new-cars/future-cars/a23496316/new-porsche-935-moby-dick-rennsport>, 2018, 6 pages.
 Padeanu, "Porsche 935 Passenger Seat is a \$10,000 Option", Motor 1. <https://www.motor1.com/news/386460/porsche-935-passenger-seat>, 2019, 2 pages.
 Rear Bumpers, (Design—© Questel) orbit.com. [Online PDF compilation of references] p. 43, retrieved Mar. 22, 2022, 43 pages.
 Legal Street Racing, Speed Hunters, retrieved at <http://www.speedhunters.com/2019/07/legal-street-racing-street-car-takeover-charlotte>, Jul. 13, 2019, 28 pages.
 Perkins, What's the Difference Between Race and Road Cars, Road and Track, downloaded at <https://www.roadandtrack.com/car-culture/buying-maintenance/videos/a31500/race-car-road-car-differences>, Nov. 9, 2016, 5 pages.
 Street racing cars, Facebook, downloaded at https://www.facebook.com/pg/Street-racing-cars-115477820356778/posts/?ref=page_internal, Dec. 12, 2020, 3 pages.
 Non Final Office Action for U.S. Appl. No. 29/801,915, dated Apr. 1, 2022, 18 pages.

* cited by examiner

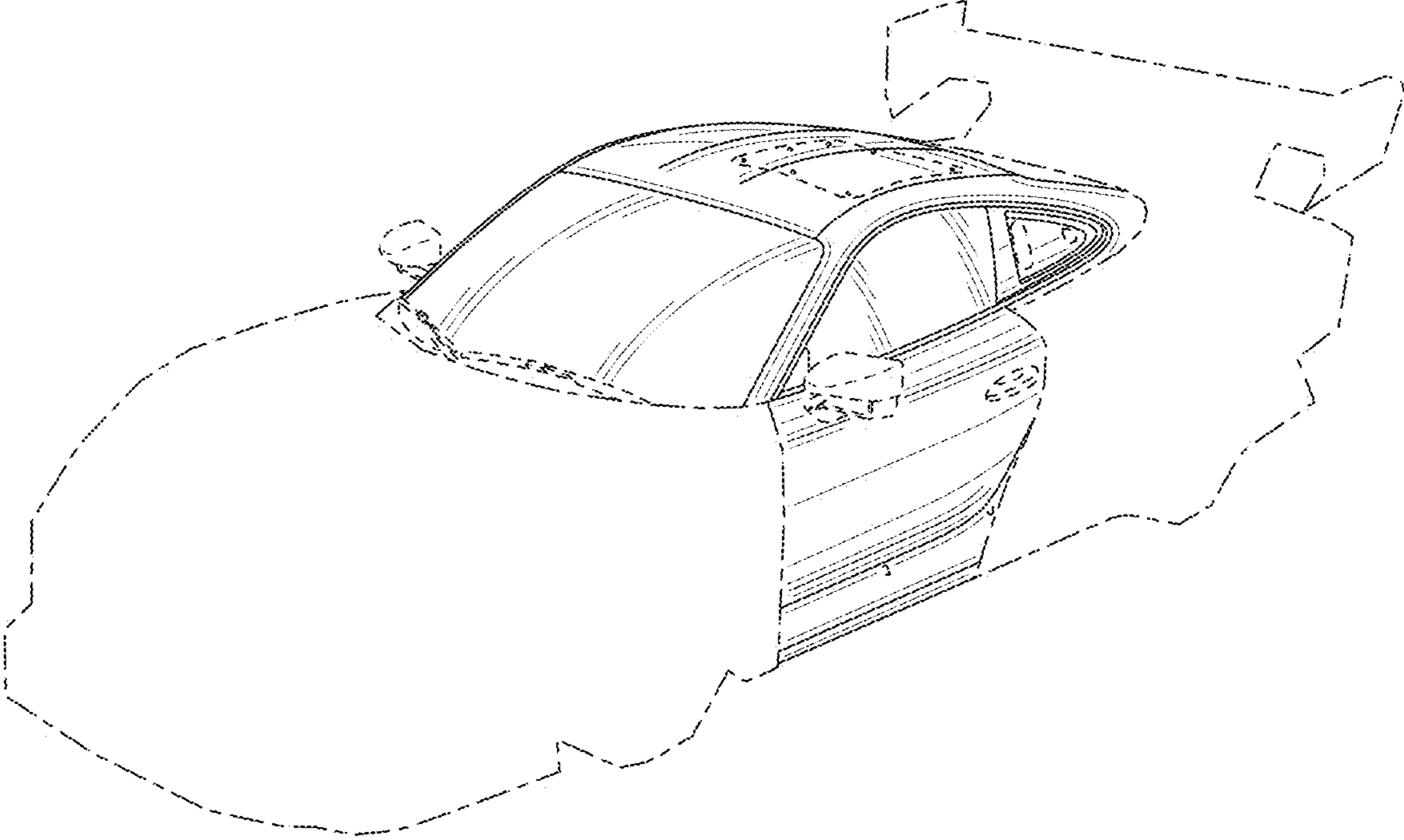

FIG. 1

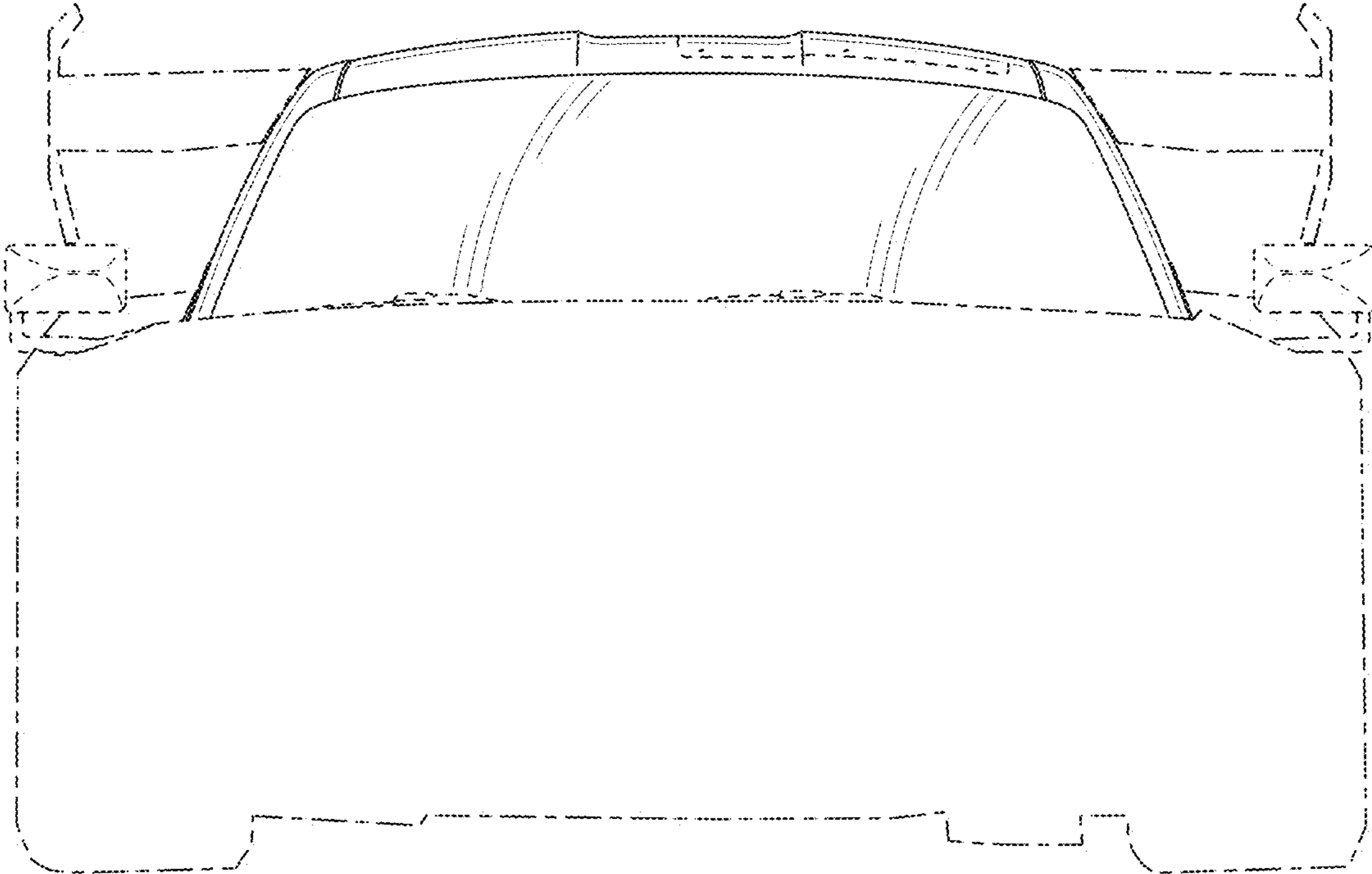

FIG. 2

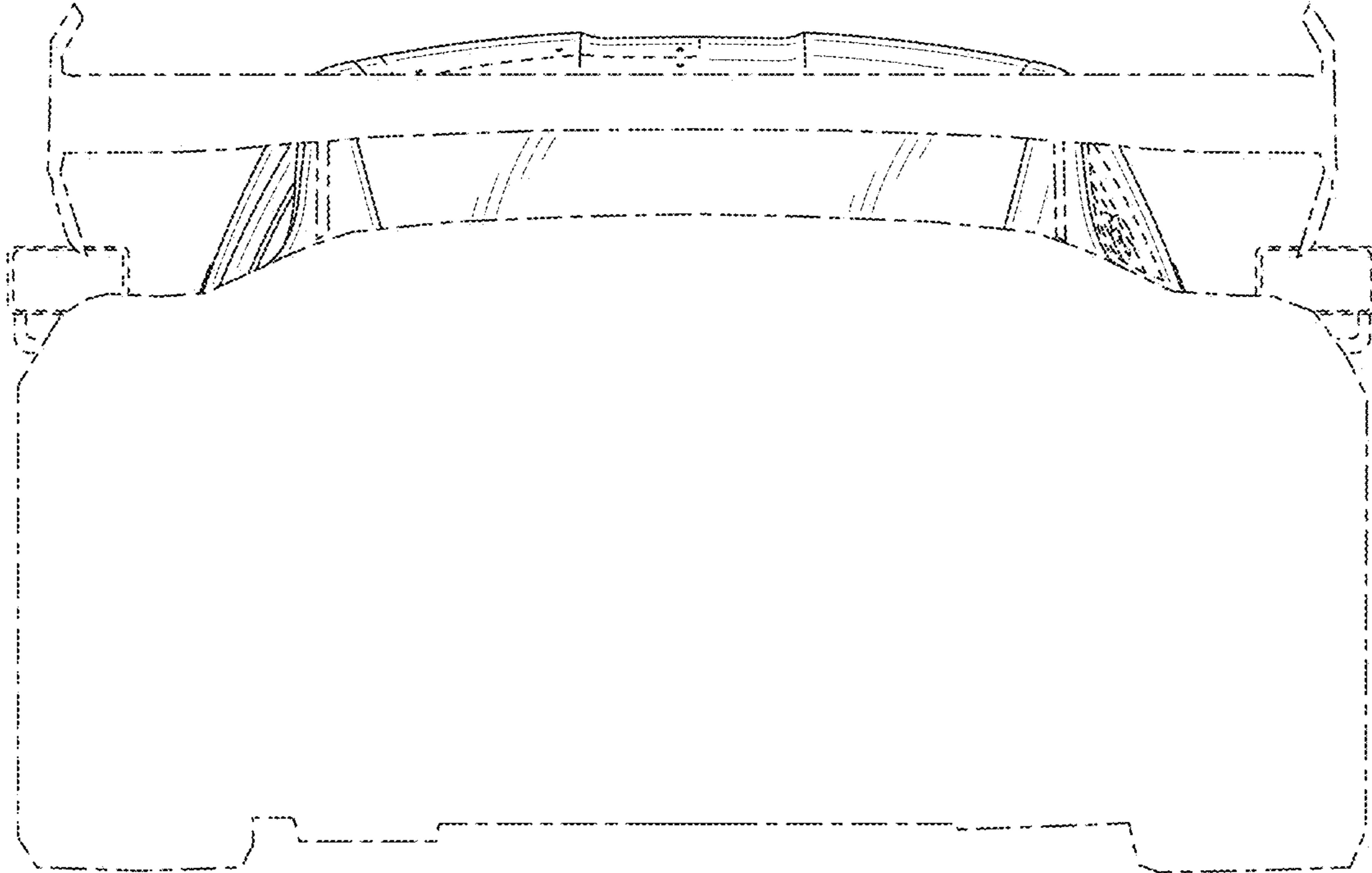

FIG. 3

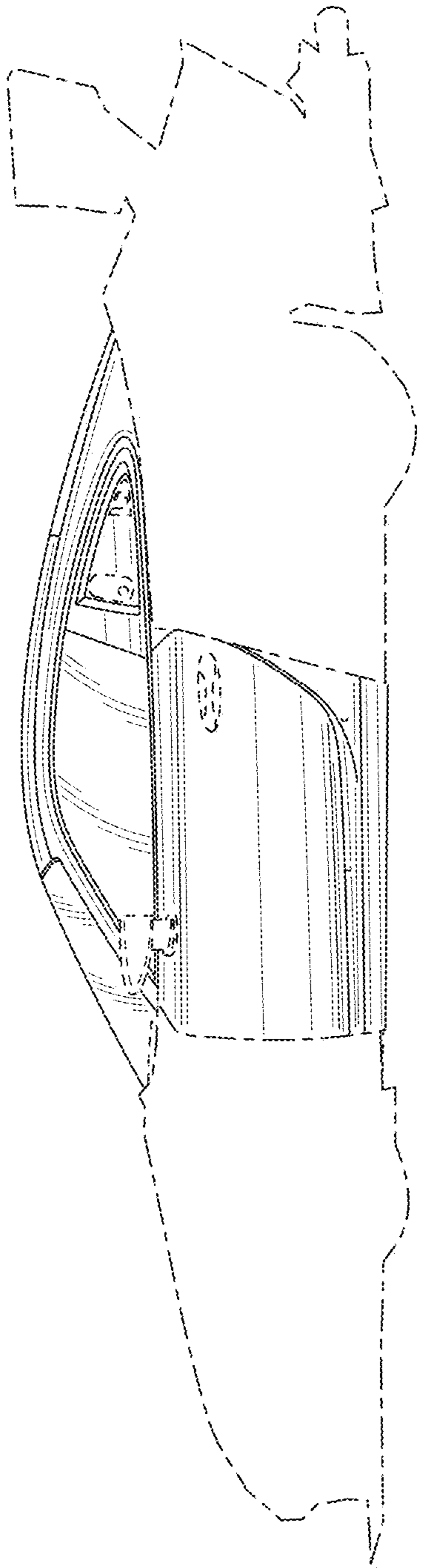

FIG. 4

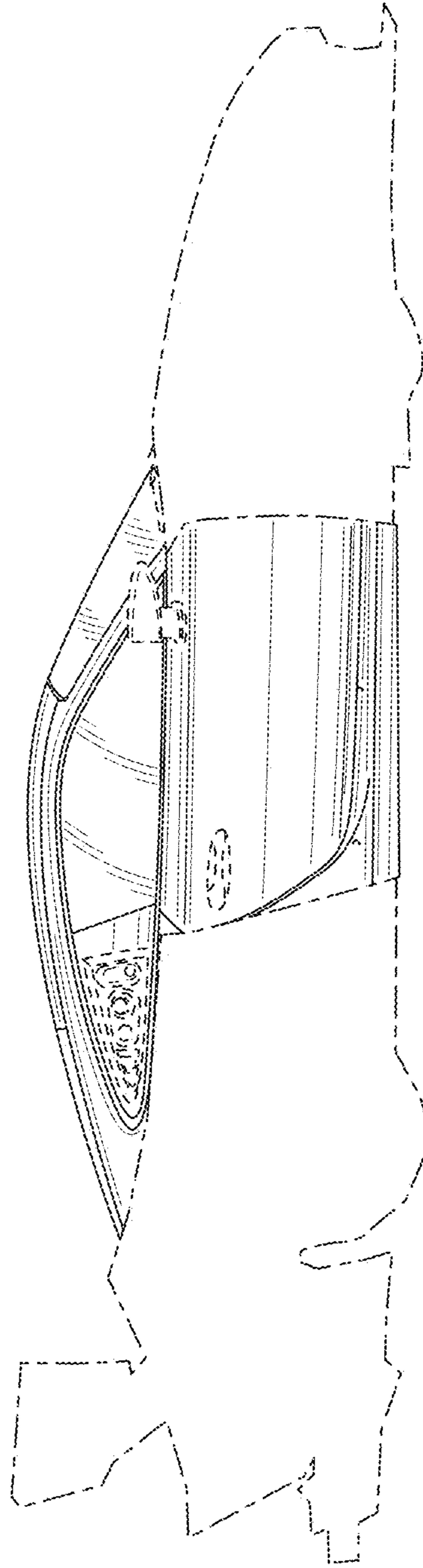

FIG. 5

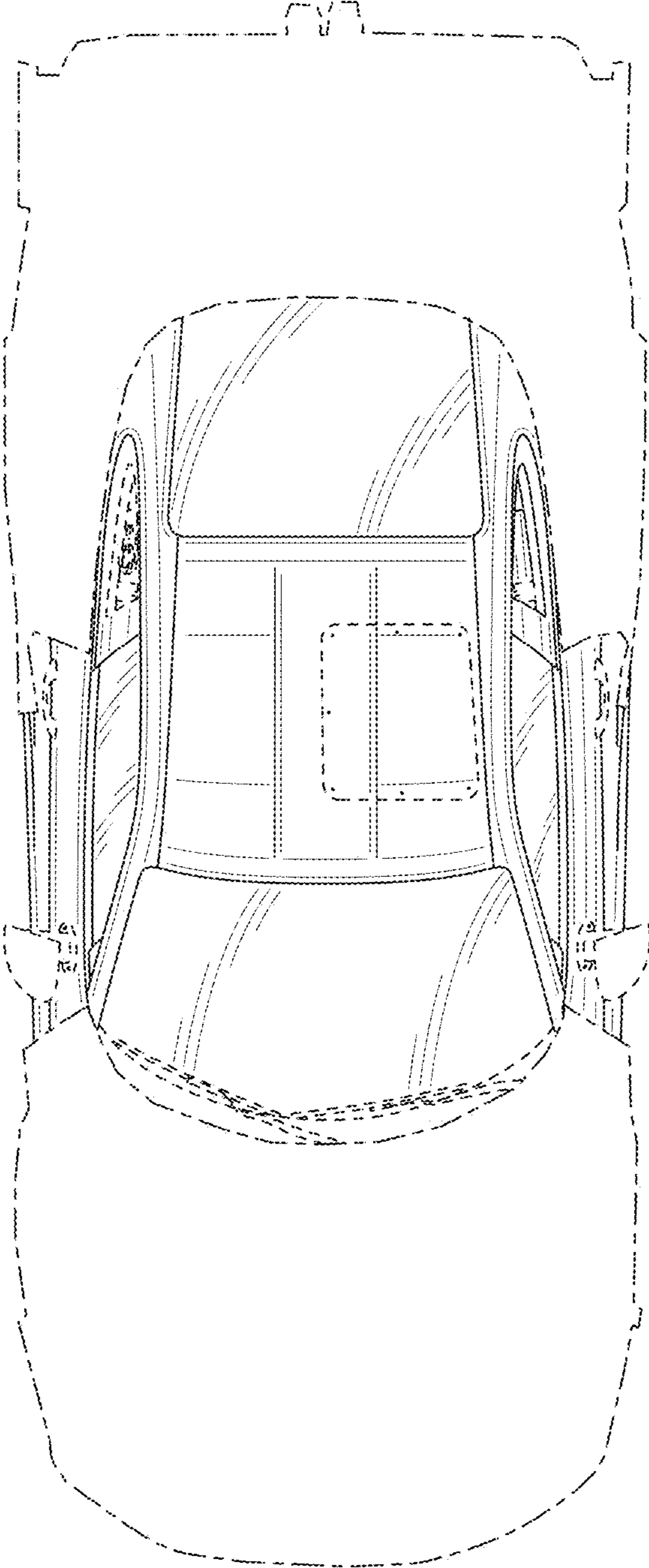

FIG. 6