



US00D963282S

(12) **United States Design Patent**
Simmendinger et al.

(10) **Patent No.:** **US D963,282 S**

(45) **Date of Patent:** **** Sep. 6, 2022**

(54) **CONVEYOR BELT MODULE**

(71) Applicant: **HABASIT ITALIANA S.P.A.,
CESANO BOSCONI, R & D
PLASTICS,
ZWEIGNIEDERLASSUNG
REINACH/BL (SCHWEIZ), Reinach
(CH)**

(72) Inventors: **Stefan Simmendinger, Wahlen b.
Laufen (CH); Andrew Richardson,
Michelbach le haut (FR)**

(**) Term: **15 Years**

(21) Appl. No.: **29/769,243**

(22) Filed: **Feb. 4, 2021**

(30) **Foreign Application Priority Data**

Nov. 20, 2020 (EM) 008277321-0002

(51) **LOC (13) Cl.** **12-05**

(52) **U.S. Cl.**
USPC **D34/29**

(58) **Field of Classification Search**
USPC D34/29, 35
CPC .. B65G 17/08; B65G 17/086; B65G 2207/12;
B65G 2201/02
See application file for complete search history.

(56) **References Cited**

U.S. PATENT DOCUMENTS

D291,777 S * 9/1987 Lapeyre D34/29
D427,898 S * 7/2000 Loh 474/212
9,085,414 B2 * 7/2015 Sharma B65G 15/30

D804,137 S * 11/2017 Fye B65G 17/08
D34/29
D924,529 S * 7/2021 Simmendinger D34/29
D924,530 S * 7/2021 Simmendinger D34/29
D924,531 S * 7/2021 Simmendinger D34/29
D934,525 S * 10/2021 Simmendinger D34/29
D934,526 S * 10/2021 Simmendinger D34/29
2002/0179418 A1 * 12/2002 Guldenfels B65G 17/06
198/853
2003/0168321 A1 * 9/2003 Kato B65G 17/08
198/851
2012/0043184 A1 * 2/2012 Marshall B65G 17/40
198/688.1
2013/0277184 A1 * 10/2013 Ozaki B65G 17/08
198/853
2016/0332821 A1 * 11/2016 van den Berg B65G 23/06

* cited by examiner

Primary Examiner — Cynthia Ramirez

(74) *Attorney, Agent, or Firm* — Egbert, McDaniel & Swartz, PLLC

(57) **CLAIM**

The ornamental design for a conveyor belt module, as shown and described.

DESCRIPTION

FIG. 1 is a front view of a conveyor belt module showing our new design.

FIG. 2 is a rear view thereof;

FIG. 3 is a top view thereof;

FIG. 4 is a bottom view thereof;

FIG. 5 is an upper perspective view thereof;

FIG. 6 is a lower perspective view thereof;

FIG. 7 is a side view thereof; and,

FIG. 8 is an opposite side view thereof.

1 Claim, 2 Drawing Sheets

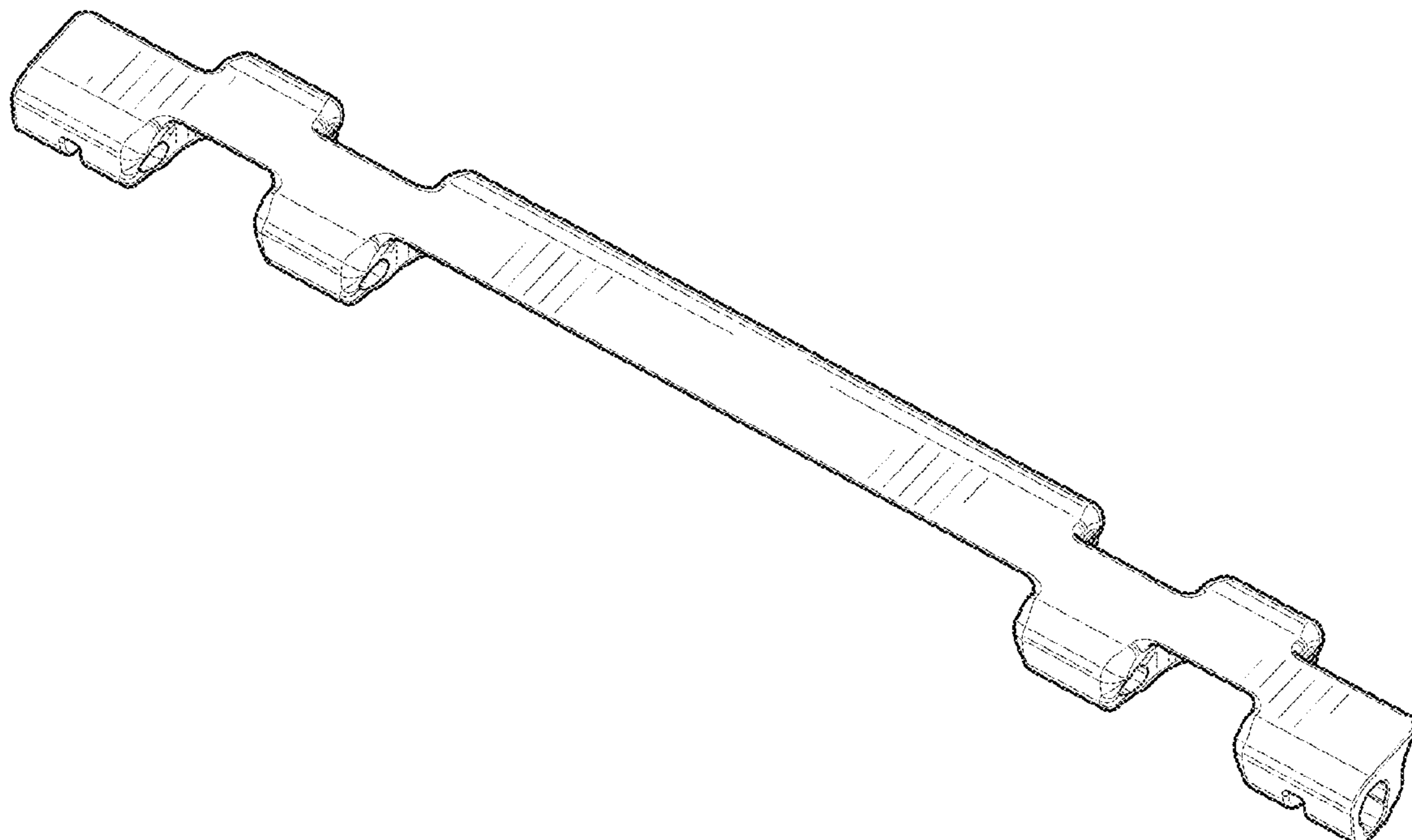

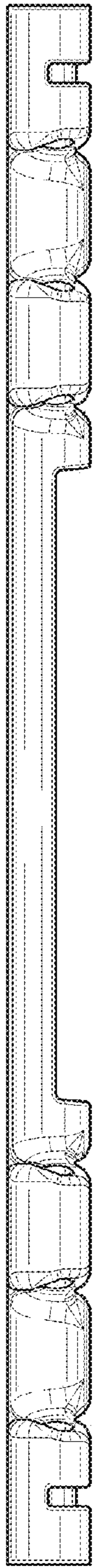

FIG. 1



FIG. 2

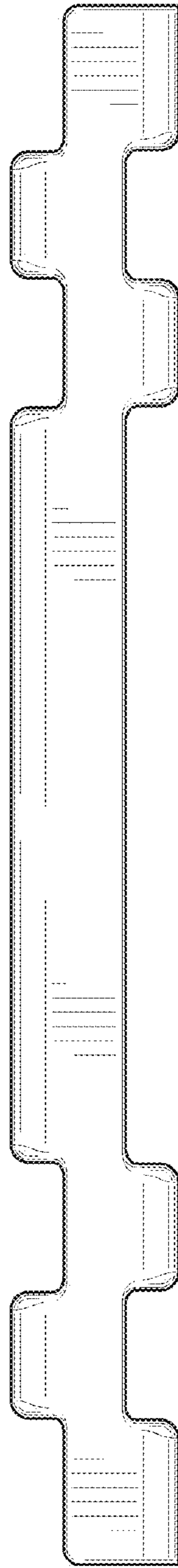

FIG. 3

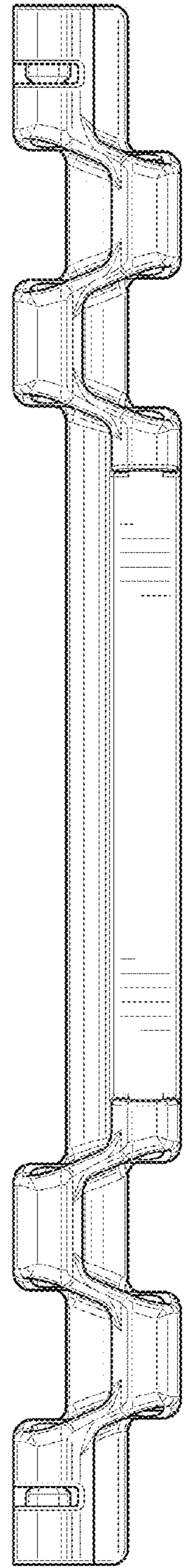

FIG. 4

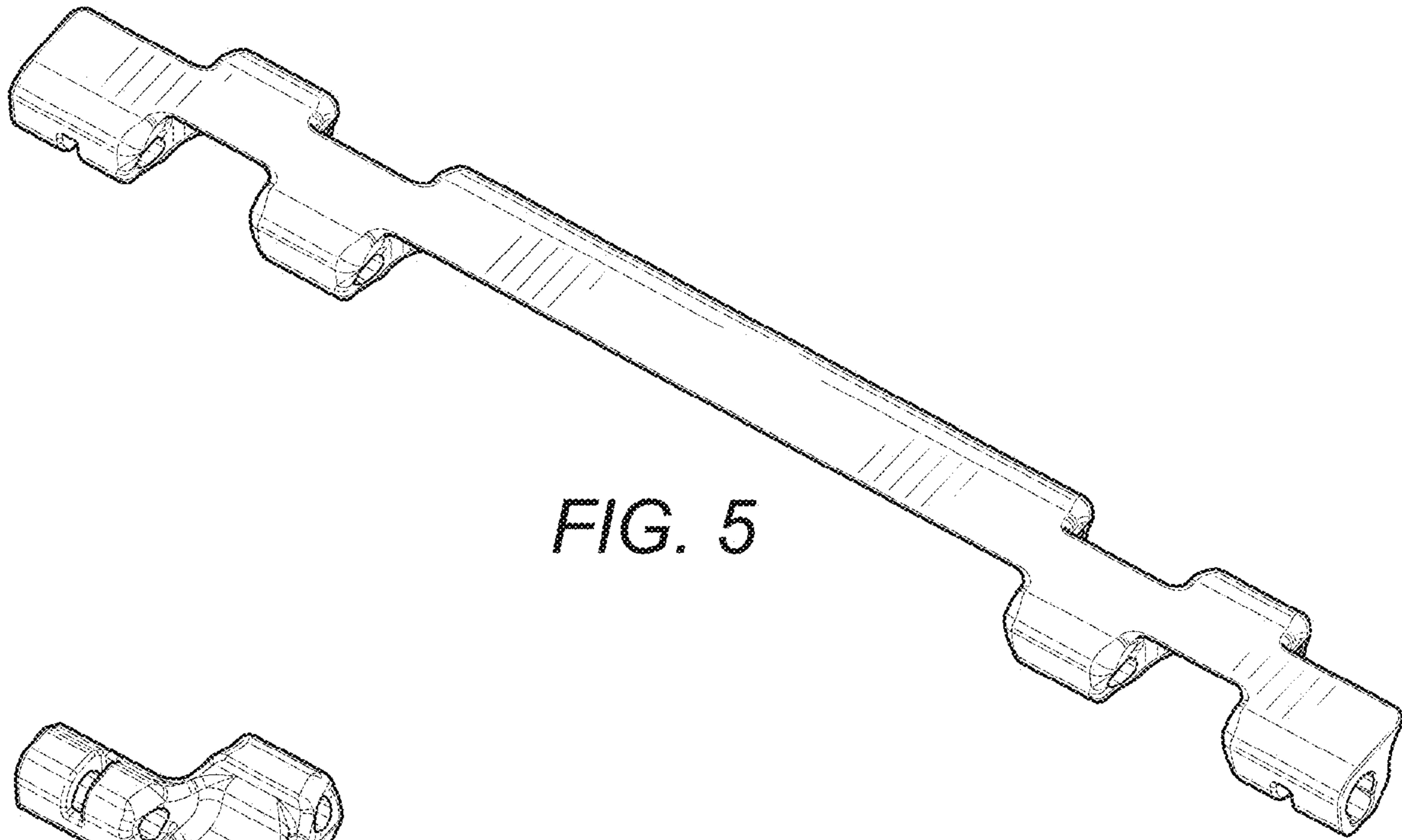

FIG. 5

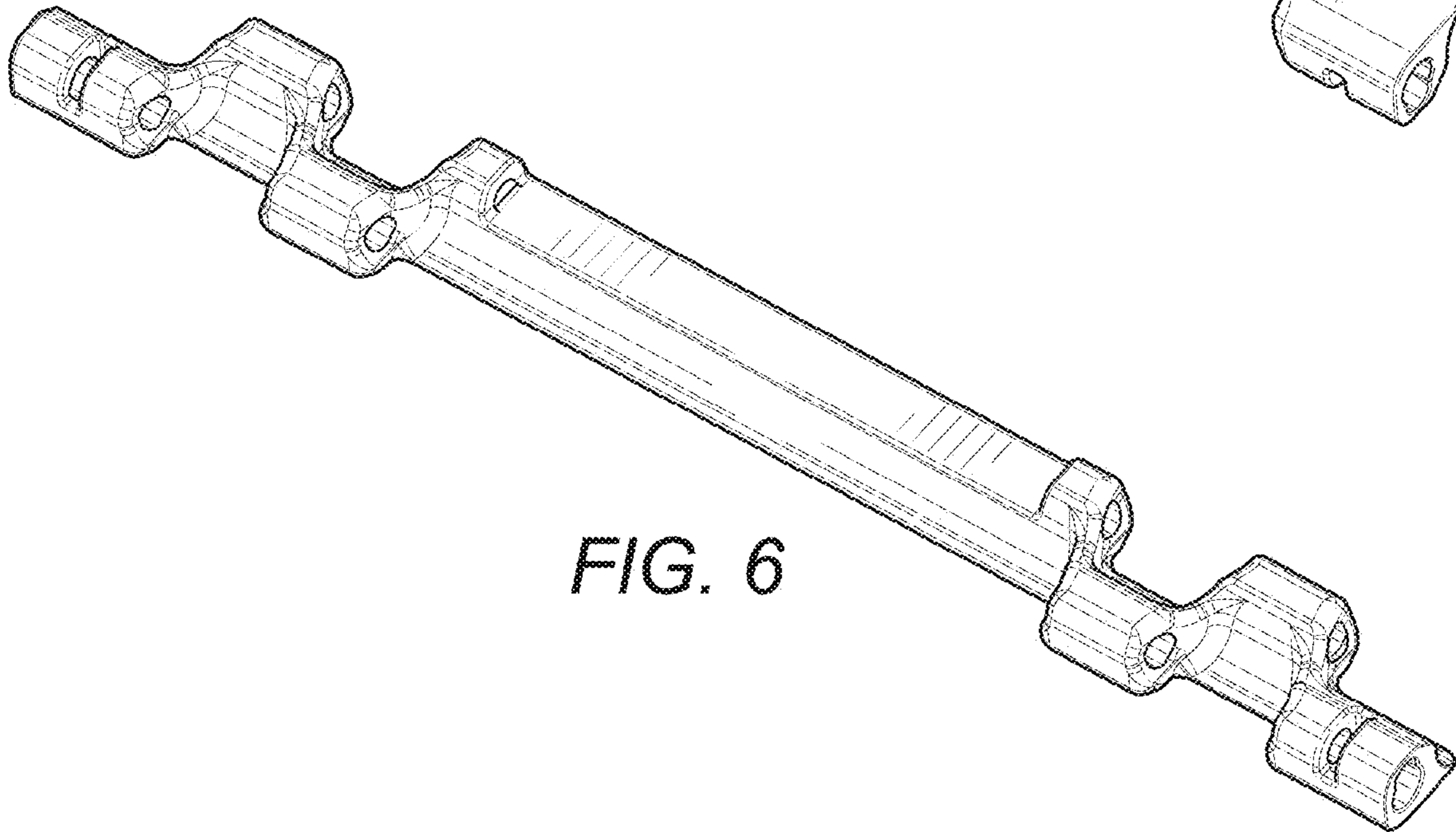

FIG. 6

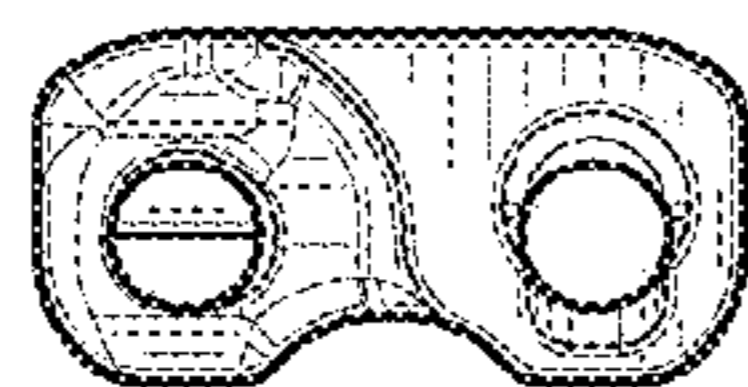

FIG. 7

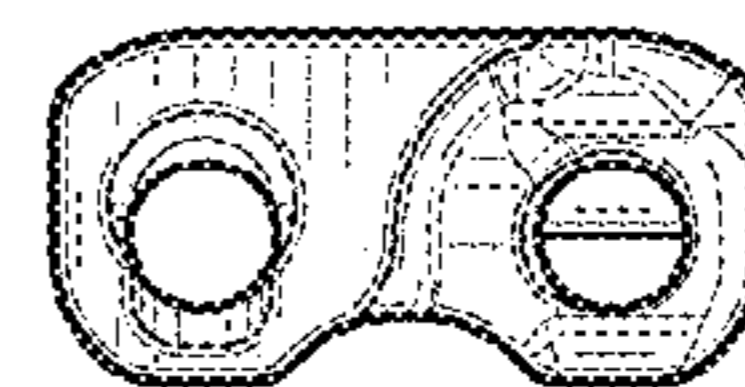

FIG. 8