

US00D962883S

(12) **United States Design Patent**
Tomori

(10) **Patent No.:** **US D962,883 S**

(45) **Date of Patent:** **** *Sep. 6, 2022**

(54) **TEMPORARY PROTECTIVE FILM FOR MANUFACTURING SEMICONDUCTOR DEVICES**

(71) Applicant: **Showa Denko Materials Co., Ltd.**,
Tokyo (JP)

(72) Inventor: **Naoki Tomori**, Tokyo (JP)

(73) Assignee: **SHOWA DENKO MATERIALS CO., LTD.**, Tokyo (JP)

(*) Notice: This patent is subject to a terminal disclaimer.

(**) Term: **15 Years**

(21) Appl. No.: **35/512,766**

(22) Filed: **Apr. 22, 2021**

(80) **Hague Agreement Data**

Int. Filing Date: **Apr. 22, 2021**

Int. Reg. No.: **DM/213977**

Int. Reg. Date: **Apr. 22, 2021**

Int. Reg. Pub. Date: **Oct. 22, 2021**

(30) **Foreign Application Priority Data**

Nov. 2, 2020 (JP) 2020-023694 D

Nov. 2, 2020 (JP) 2020-023695 D

(51) **LOC (13) Cl.** **13-99**

(52) **U.S. Cl.**
USPC **D13/199**

(58) **Field of Classification Search**
USPC D13/182, 180; D19/69, 67; D24/189

(Continued)

(56) **References Cited**

U.S. PATENT DOCUMENTS

2,080,052 A * 5/1937 Lemaster A61F 15/002
83/597

2,082,546 A * 6/1937 Machate A61F 15/002
225/45

(Continued)

OTHER PUBLICATIONS

“Establishing . . .” reference dated Sep. 13, 2018 on the internet at:
https://www.mc.showadenko.com/english/information/2018/n_180913uo3.html.*

(Continued)

Primary Examiner — Rhea Shields

(74) *Attorney, Agent, or Firm* — Fitch, Even, Tabin & Flannery, LLP

(57) **CLAIM**

The ornamental design for a temporary protective film for manufacturing semiconductor devices, as shown and described.

DESCRIPTION

Temporary protective film for manufacturing semiconductor devices

FIG. 1.1 is a perspective view of a temporary protective film for manufacturing semiconductor devices showing my design;

FIG. 1.2 is another perspective view thereof;

FIG. 1.3 is another perspective view thereof;

FIG. 1.4 is a front view thereof;

FIG. 1.5 is a back view thereof;

FIG. 1.6 is a top view thereof;

FIG. 1.7 is a bottom view thereof;

FIG. 1.8 is a left side view thereof;

FIG. 1.9 is a right side view thereof;

FIG. 1.10 is a sectional view thereof along lines A-A in FIG. 1.8.

The article includes a core part and a film part, and is characterized by the fact that the width of the core part is smaller than the width of the film part, and the film part is wound while partially protruding from the core part; each article is temporarily attached to a back of a lead frame when manufacturing a semiconductor device with only one side encapsulated and the lead frame on the back side exposed; the film part of each article has an adhesive layer on one side; since the core part does not protrude from the film part, each article can be easily positioned when set to equipment for manufacturing semiconductor devices, and it is possible

(Continued)

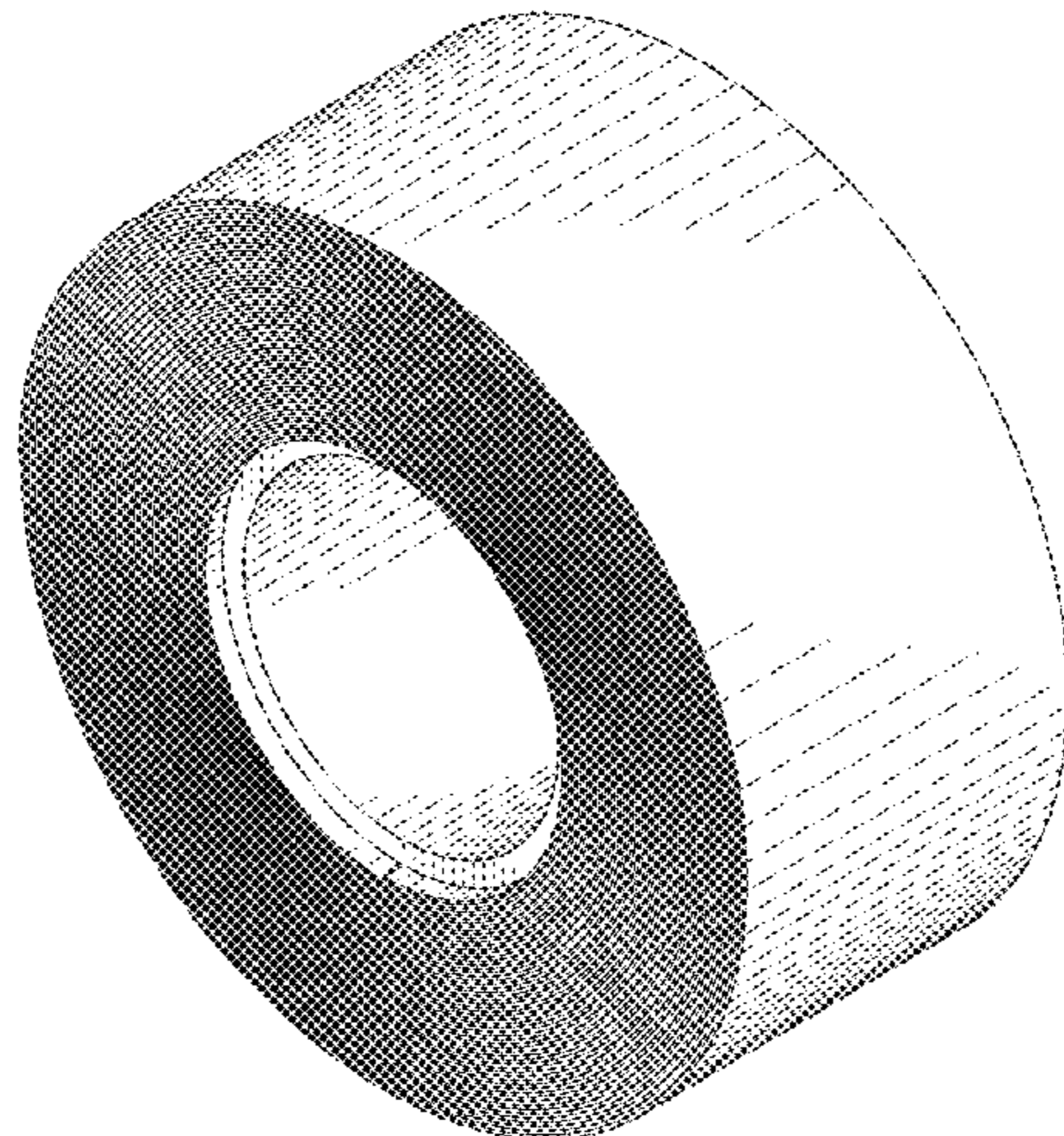

to prevent the article from being misaligned when it is temporarily adhered to the back surface of the lead frame. The parallel thin lines in the representation represent contours only and do not illustrate an ornamentation or decoration on the surface of the product.

1 Claim, 10 Drawing Sheets

(58) **Field of Classification Search**

CPC B65H 35/0033; B65H 35/0026; B65H 35/008; A61F 15/002; B42F 21/00; B65D 85/672; G11C 11/06; H05K 7/209; C09J 7/385; C09J 133/068

See application file for complete search history.

(56) **References Cited**

U.S. PATENT DOCUMENTS

2,229,961 A * 1/1941 Deane B65H 35/008
225/19
2,414,333 A * 1/1947 Schieman B65D 85/672
225/66
2,626,666 A * 1/1953 Coldiron B65H 35/008
225/65
2,694,533 A * 11/1954 Zucker B65H 35/0026
242/588.6
2,699,251 A * 1/1955 Rizza B65H 35/0026
225/34
3,001,306 A * 9/1961 Wilkinson B42F 21/00
40/641
3,187,968 A * 6/1965 Favre B65H 35/0033
225/56
3,216,634 A * 11/1965 Lausa B65H 35/0026
225/19

3,237,174 A * 2/1966 Di Matteo G11C 11/06
365/59
4,983,932 A * 1/1991 Kitagawa H01F 17/06
324/127
5,258,888 A * 11/1993 Korinsky H05K 7/209
361/690
D433,061 S * 10/2000 Shen D19/67
D571,859 S * 6/2008 Harmston D19/69
7,669,631 B2 * 3/2010 Bailey B65H 35/0033
156/523
D621,051 S * 8/2010 Kase D24/189
D621,803 S * 8/2010 Maruyama D13/182
D656,909 S * 4/2012 Taniguchi D13/182
D656,910 S * 4/2012 Taniguchi D13/182
D664,511 S * 7/2012 Taniguchi D13/182
D664,512 S * 7/2012 Taniguchi D13/182
D680,505 S * 4/2013 Taniguchi D13/182
D689,831 S * 9/2013 Taniguchi D13/180
D690,278 S * 9/2013 Taniguchi D13/180
D741,406 S * 10/2015 Doucette D19/69
D804,435 S * 12/2017 Taniguchi D13/180
D847,258 S * 4/2019 Kang D19/69
2007/0241436 A1 * 10/2007 Ookubo C09J 133/068
257/678
2010/0080989 A1 * 4/2010 Asai C09J 7/385
428/345

OTHER PUBLICATIONS

“RD Series . . . ” reference dated Nov. 6, 2021 on the internet at: <https://www.mc.showadenko.com/english/products/pm/015.html>.
*
“Disposal . . . ” reference dated Nov. 6, 2021 on the internet at: <https://www.pvawatersolublefilm.com/sale-11363692-disposable-high-temperature-water-soluble-plastic-film-for-mold-release.html>.
*
“Back-grinding . . . ” reference dated Nov. 6, 2021 on the internet at: <https://www.nitto.com/us/en/products/semicon/>.
*

* cited by examiner

1.1

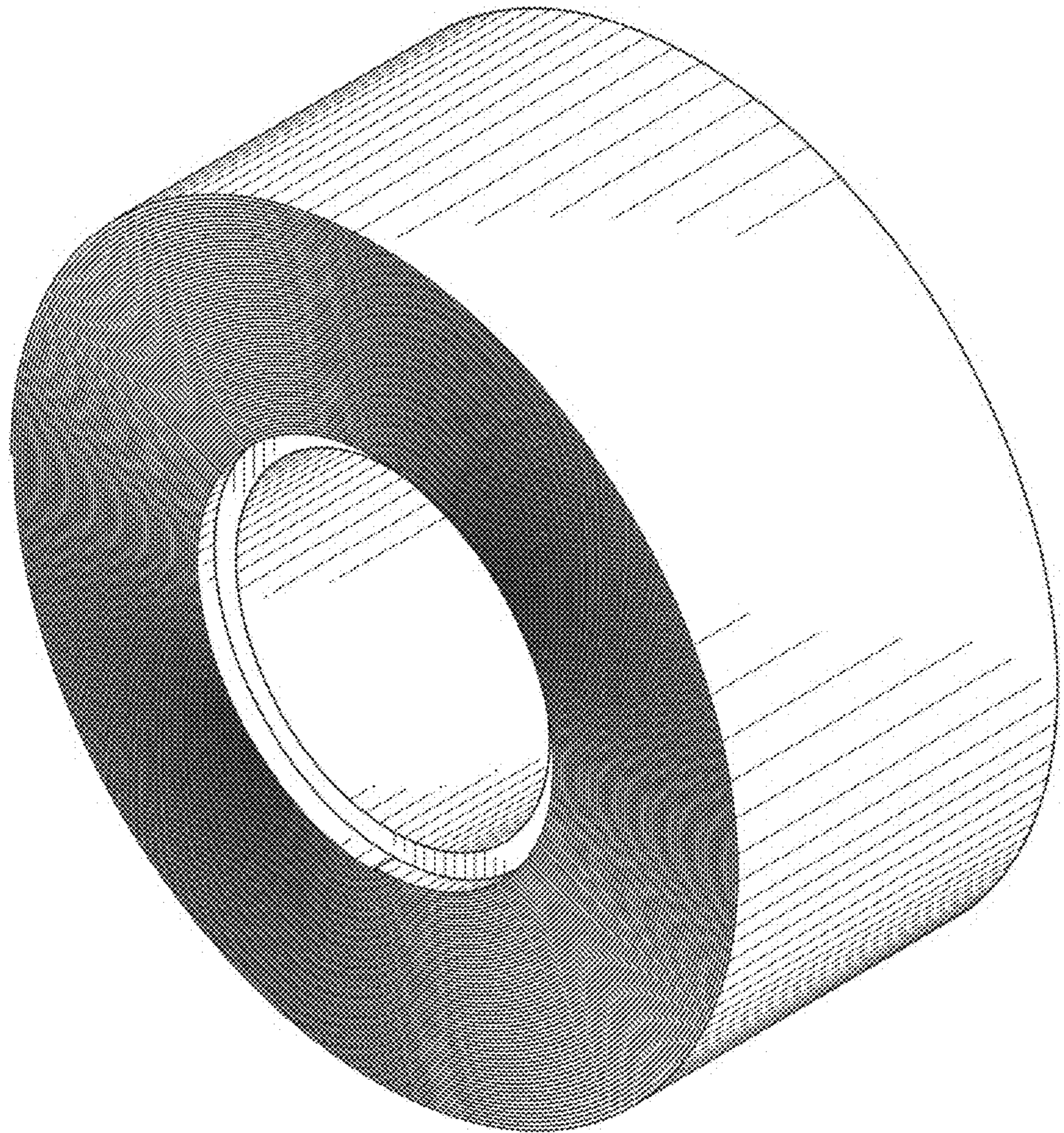

1.2

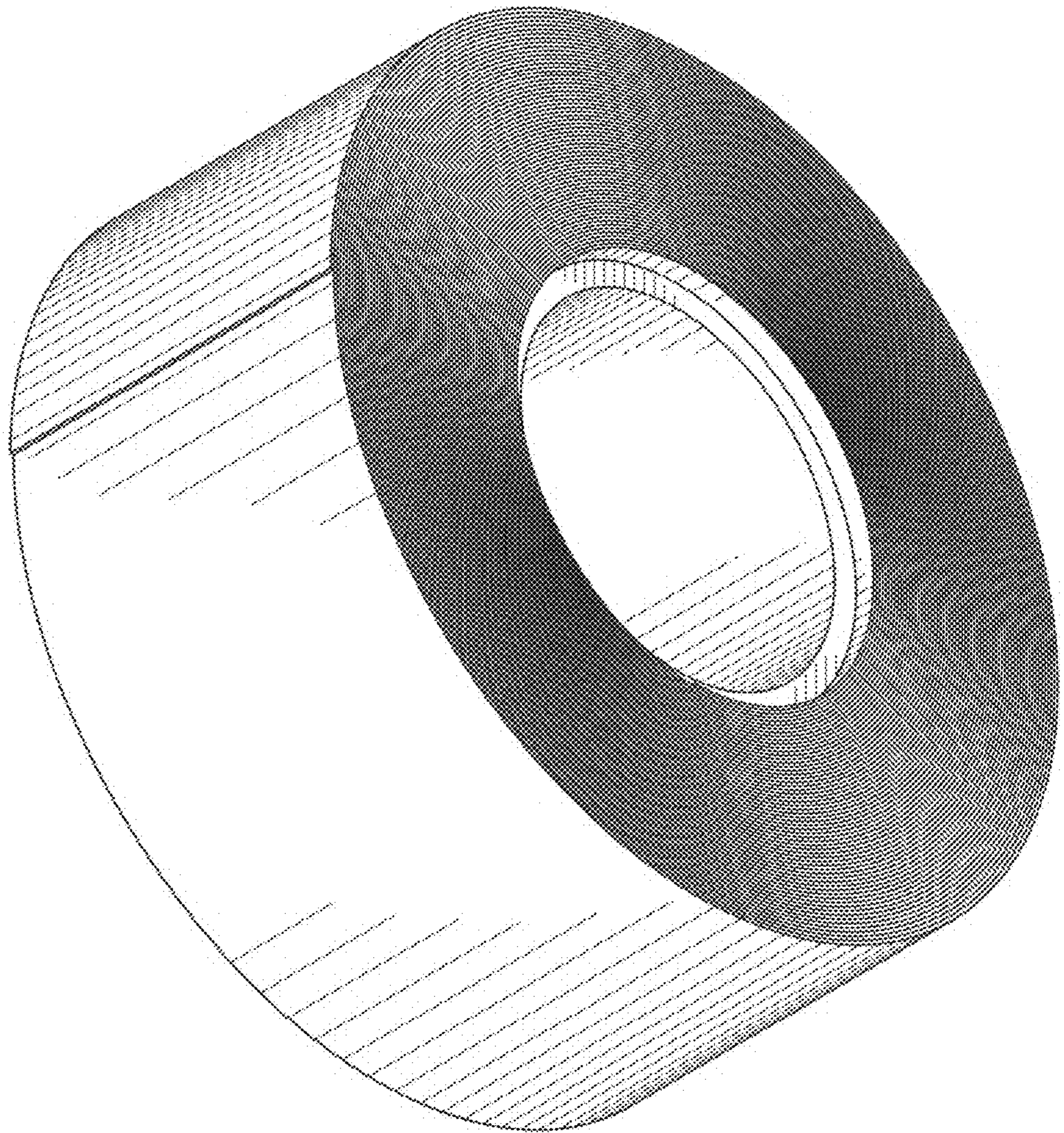

1.3

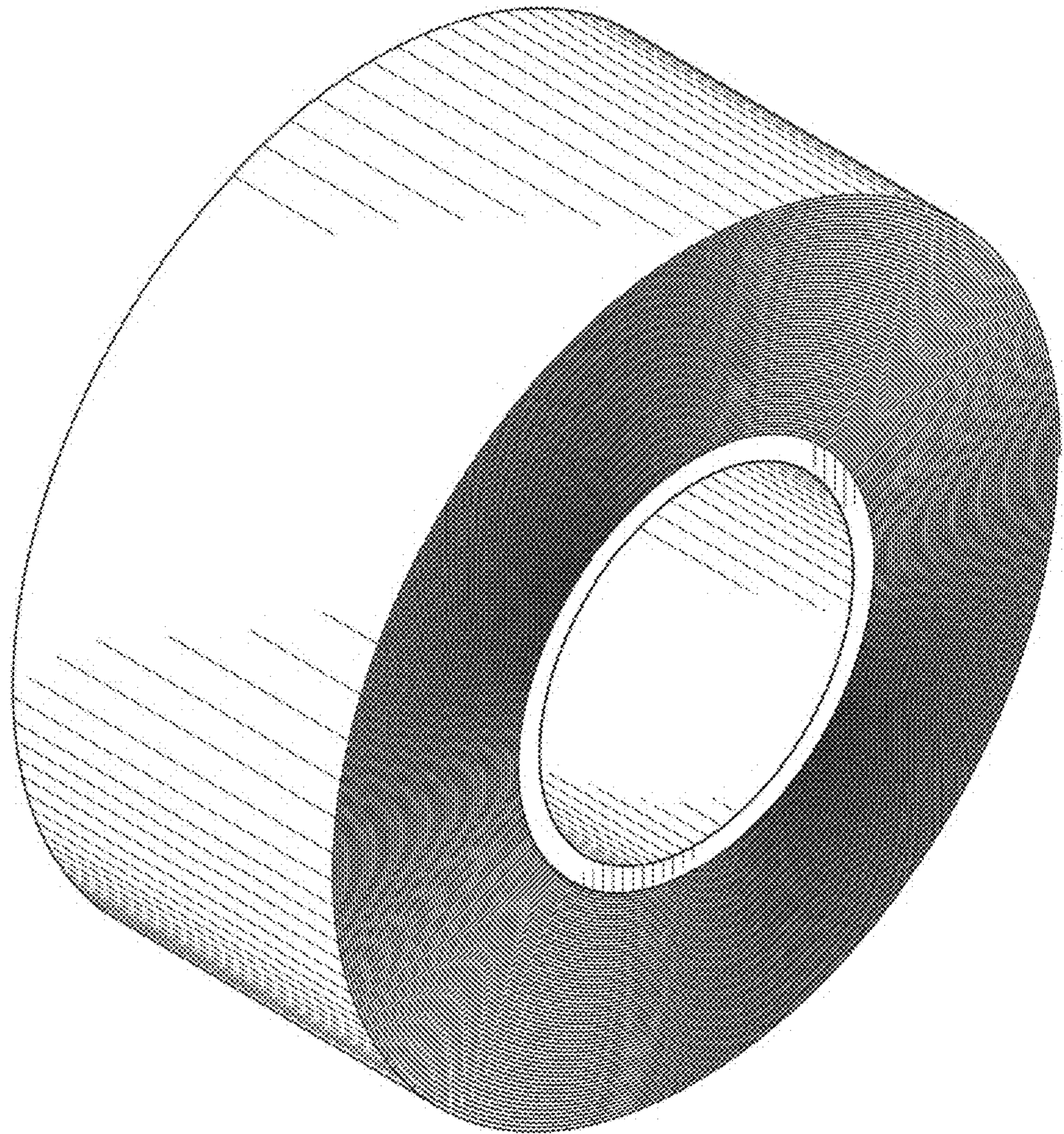

1.4

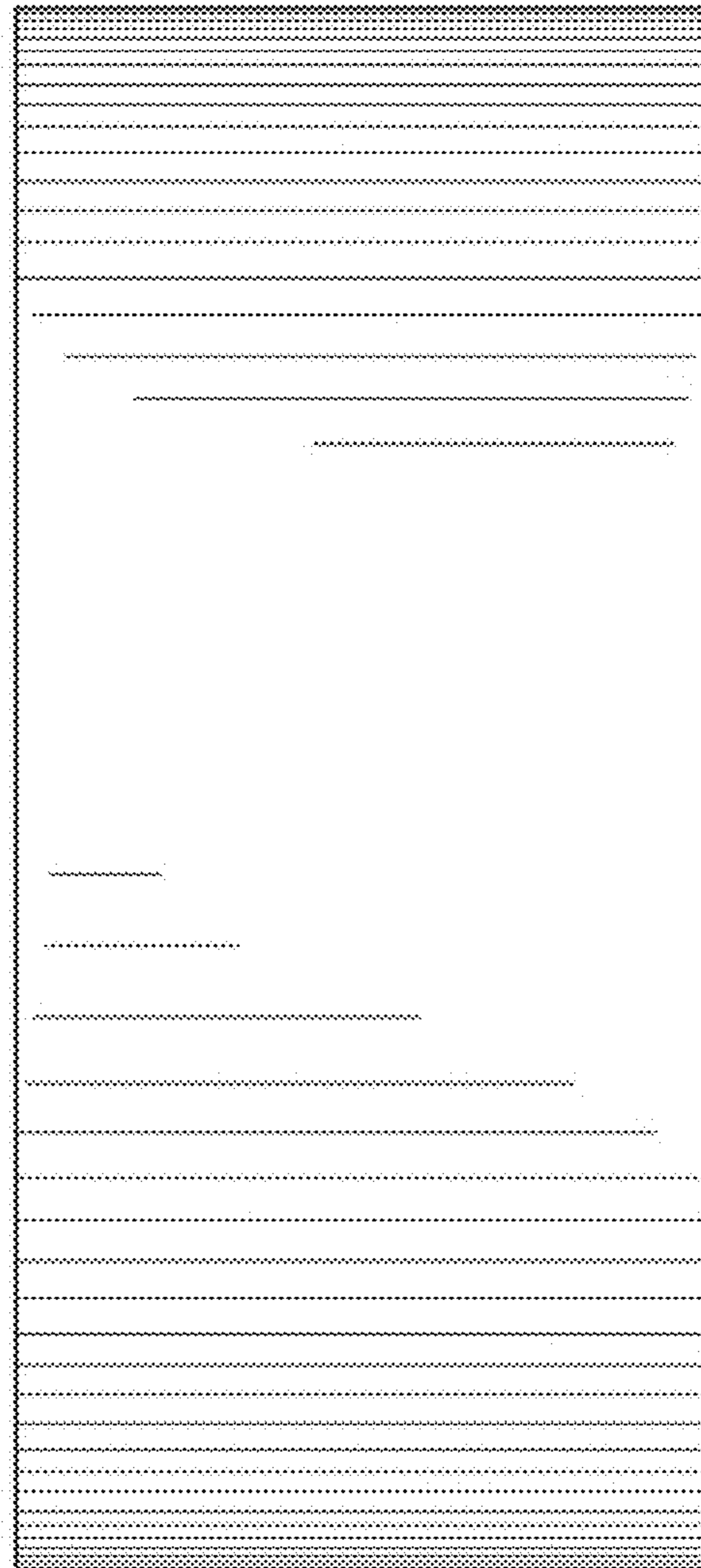

1.5

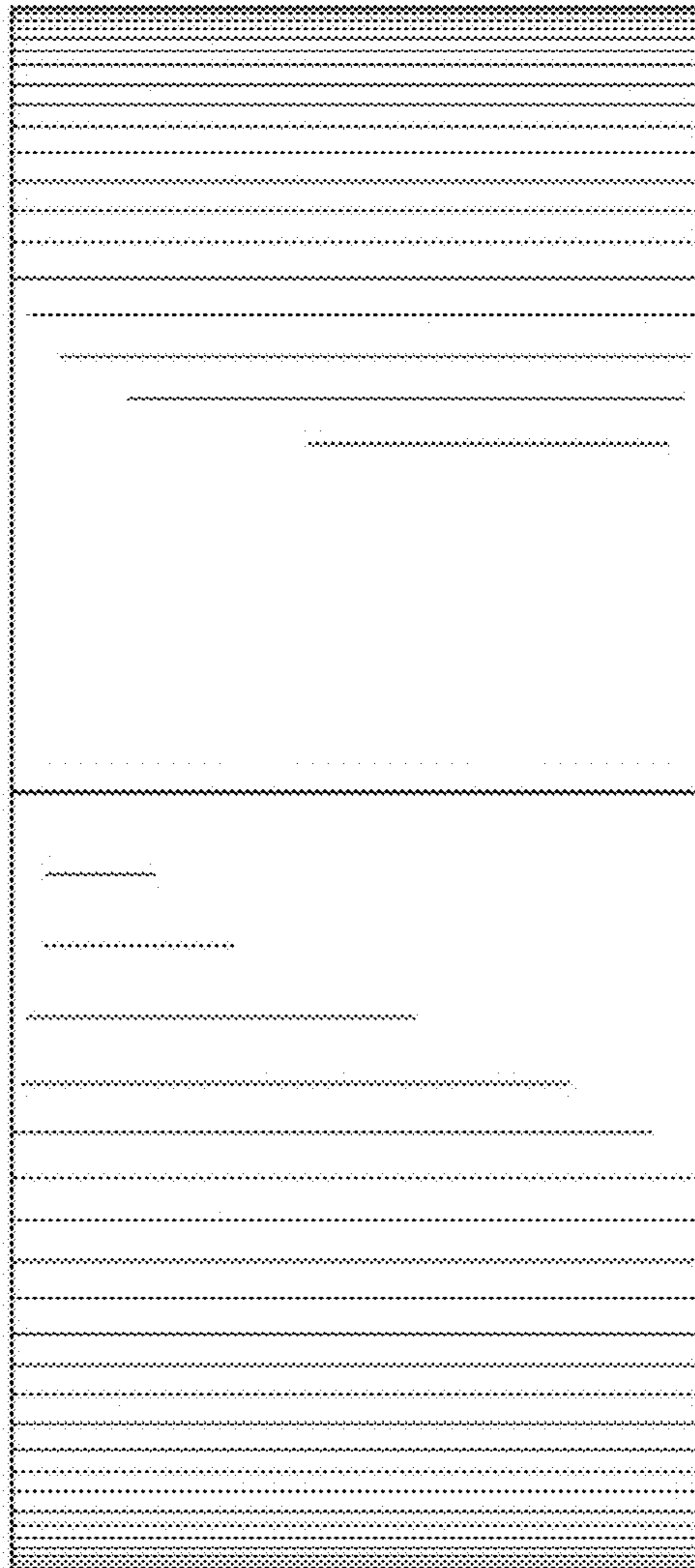

1.6

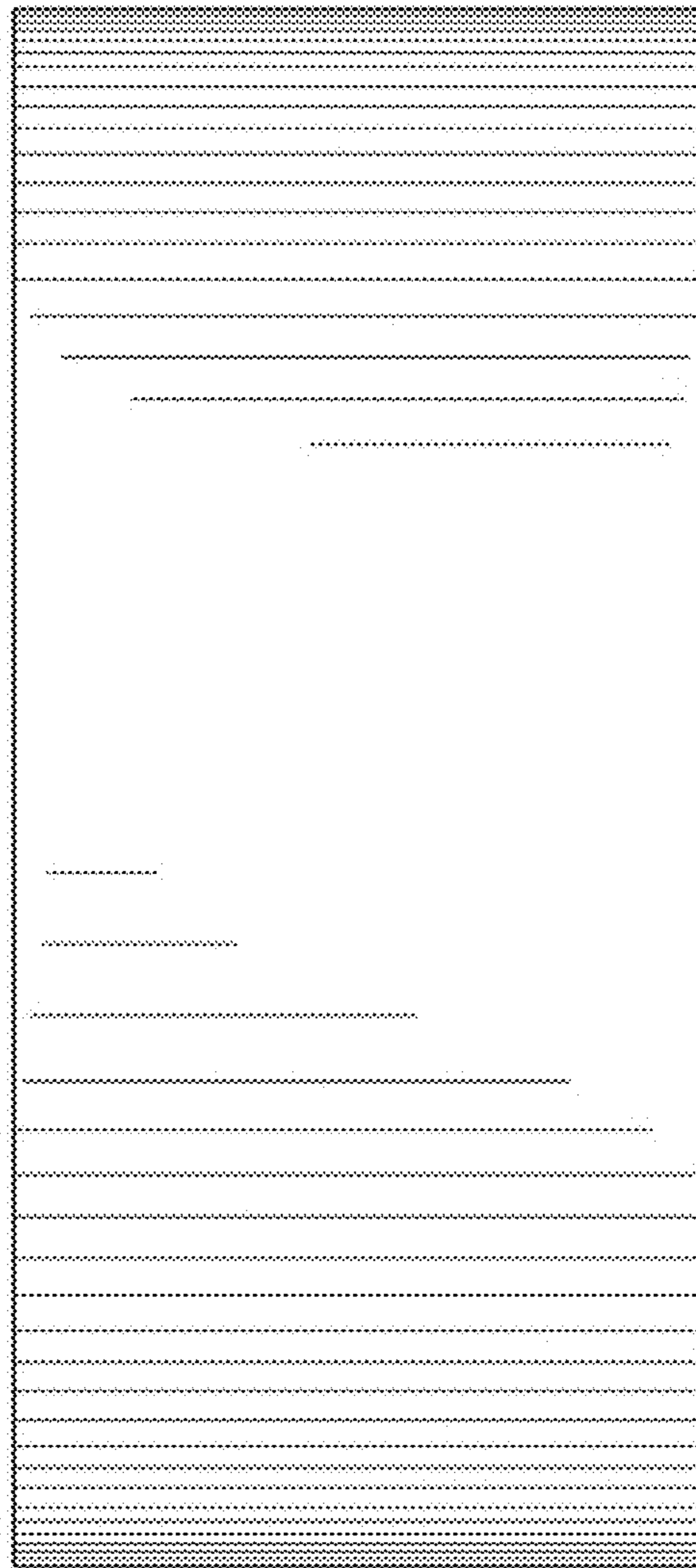

1.7

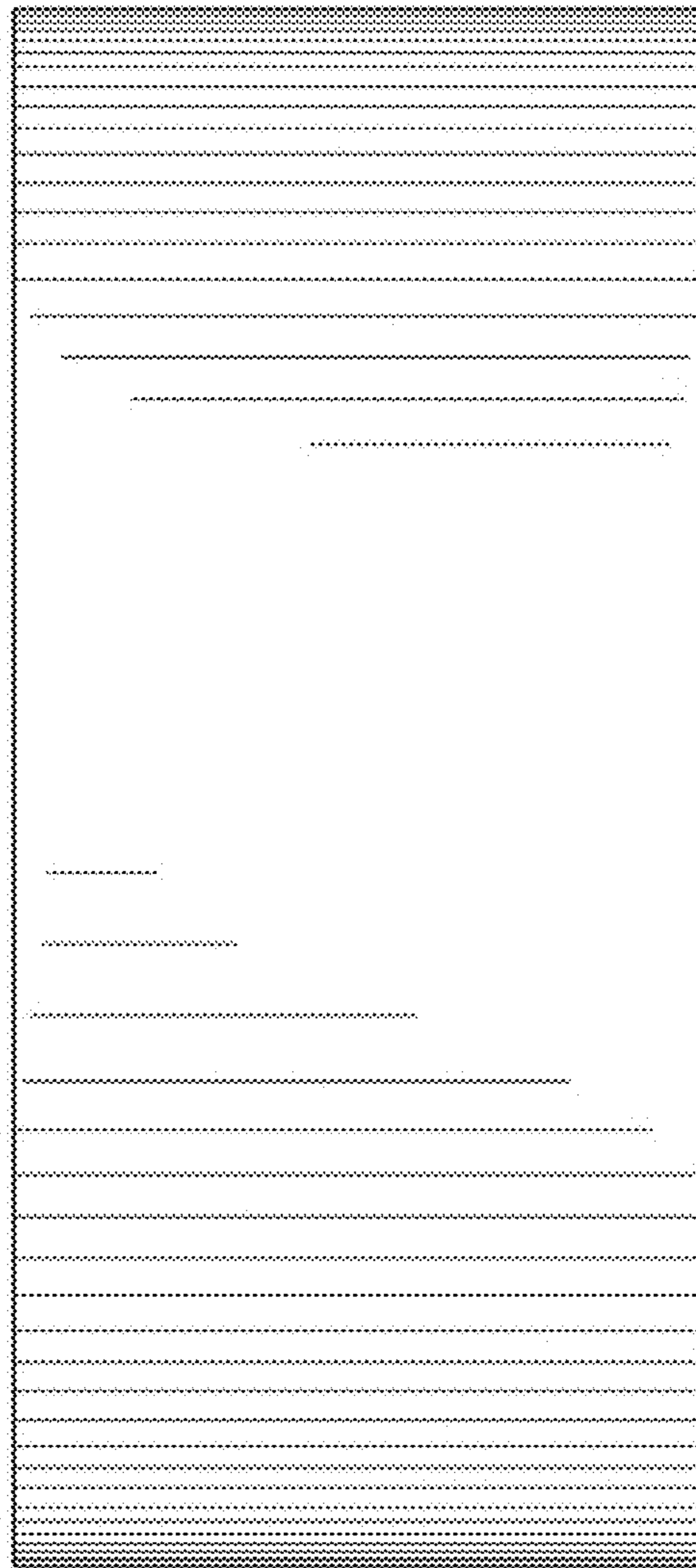

1.8

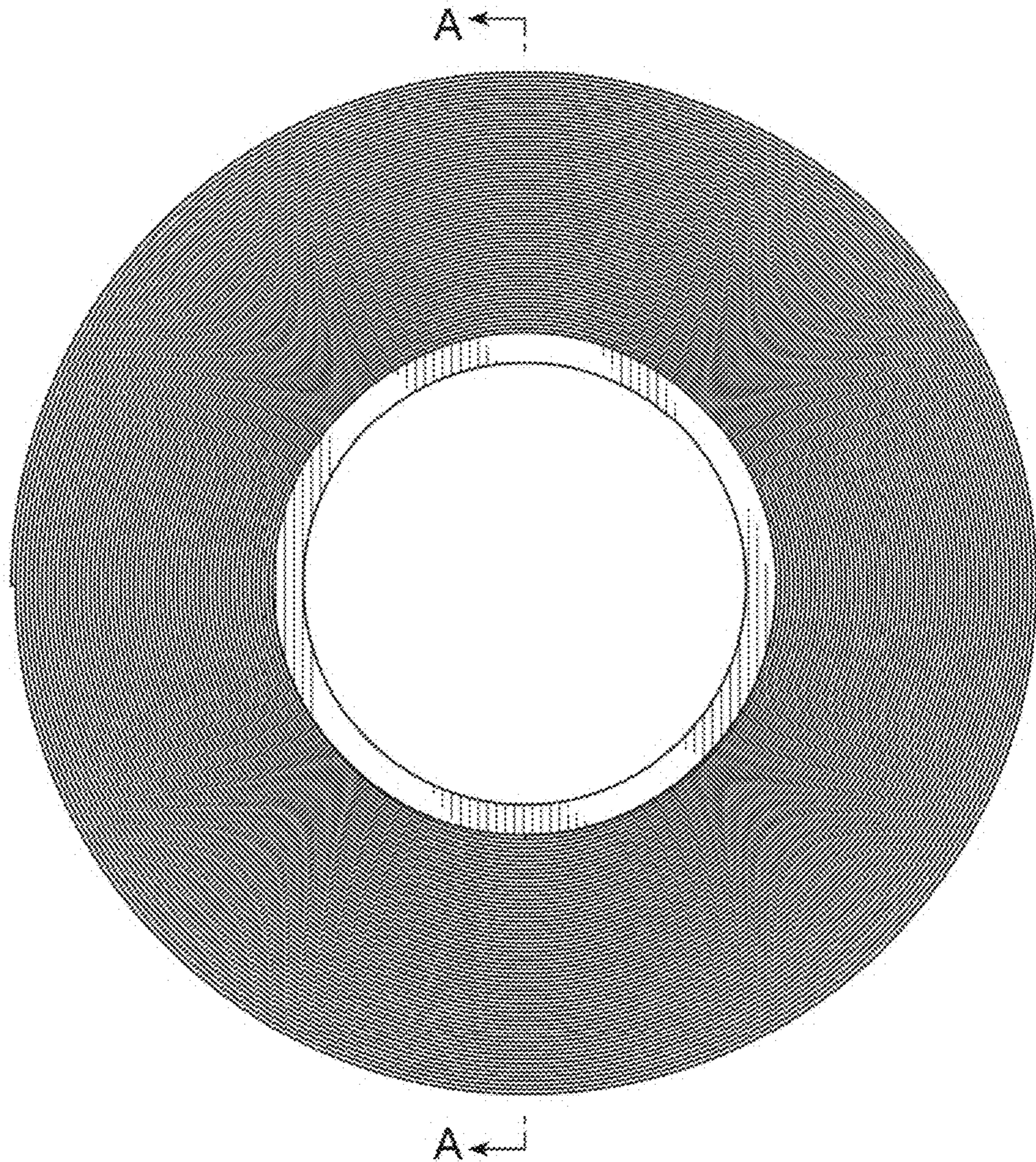

1.9

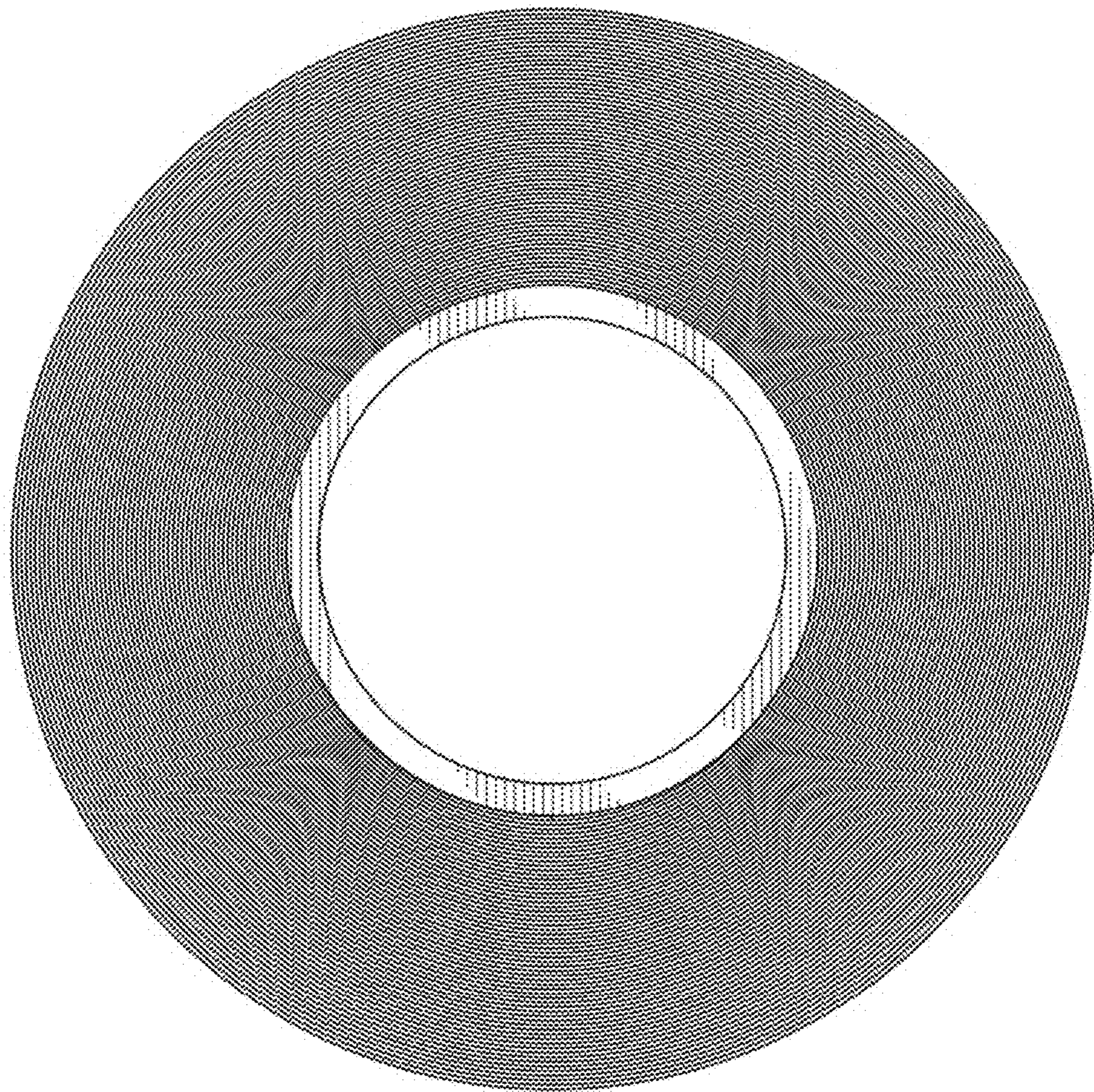

1.10

