

US00D962583S

(12) **United States Design Patent** (10) **Patent No.:** **US D962,583 S**
Su et al. (45) **Date of Patent:** **** Aug. 30, 2022**

(54) **OFF-ROAD JACK**

- (71) Applicant: **Austin International Manufacturing, Inc.**, Torrance, CA (US)
- (72) Inventors: **Austin Su**, Torrance, CA (US); **Benson Su**, Torrance, CA (US); **Charles Foreman**, Brea, CA (US)
- (73) Assignee: **Austin International Manufacturing, Inc.**, Torrance, CA (US)

(**) Term: **15 Years**

(21) Appl. No.: **29/750,648**

(22) Filed: **Sep. 15, 2020**

(51) **LOC (13) Cl.** **12-05**

(52) **U.S. Cl.**
USPC **D34/31**

(58) **Field of Classification Search**
USPC D34/28-35
CPC B66F 3/24; B66F 3/44; B66F 5/00; B66F 5/02; B66F 5/04
See application file for complete search history.

(56) **References Cited**

U.S. PATENT DOCUMENTS

4,241,900	A *	12/1980	Okuda	B66F 5/04 254/8 B
7,036,796	B2 *	5/2006	Hsu	B66F 5/04 254/8 B
7,637,479	B2 *	12/2009	Lautzenhiser	F04B 9/14 254/2 B
2004/0065871	A1 *	4/2004	Hsu	B66F 5/04 254/8 B
2019/0169004	A1 *	6/2019	Su	B60C 7/00

OTHER PUBLICATIONS

Pro Eagle Jack, announced Jun. 2020 [online], [site visited Dec. 17, 2021]. Available from internet, URL: <https://www.proeagle.com/products/1-5-ton-big-wheel-jack-talon> (Year: 2020).*

Cat 3 Jack, announced 2021 [online], [site visited Dec. 17, 2021]. Available from internet, URL: https://www.1stgenoffroad.com/store/p1069/PowerbuiltCat3TonBigWheelOffRoadHybridJack.html# (Year: 2021).*

* cited by examiner

Primary Examiner — Cynthia Ramirez

Assistant Examiner — Tamara L Hahn

(74) *Attorney, Agent, or Firm* — Lynch LLP; Sean Lynch

(57) **CLAIM**

The ornamental design for an off-road jack, as shown and described.

DESCRIPTION

FIG. 1 is a top, front, right-side perspective view of an off-road jack
FIG. 2 is a top, rear, right-side perspective view thereof.
FIG. 3 is a front view thereof.
FIG. 4 is a rear view thereof.
FIG. 5 is a left-side view thereof.
FIG. 6 is a right-side view thereof.
FIG. 7 is a top view thereof; and,
FIG. 8 is a bottom view thereof.
The broken lines showing wheels, tires, fasteners, a left extender, and a lever arm represent unclaimed portions of the off-road jack form no part of the claimed design.

1 Claim, 6 Drawing Sheets

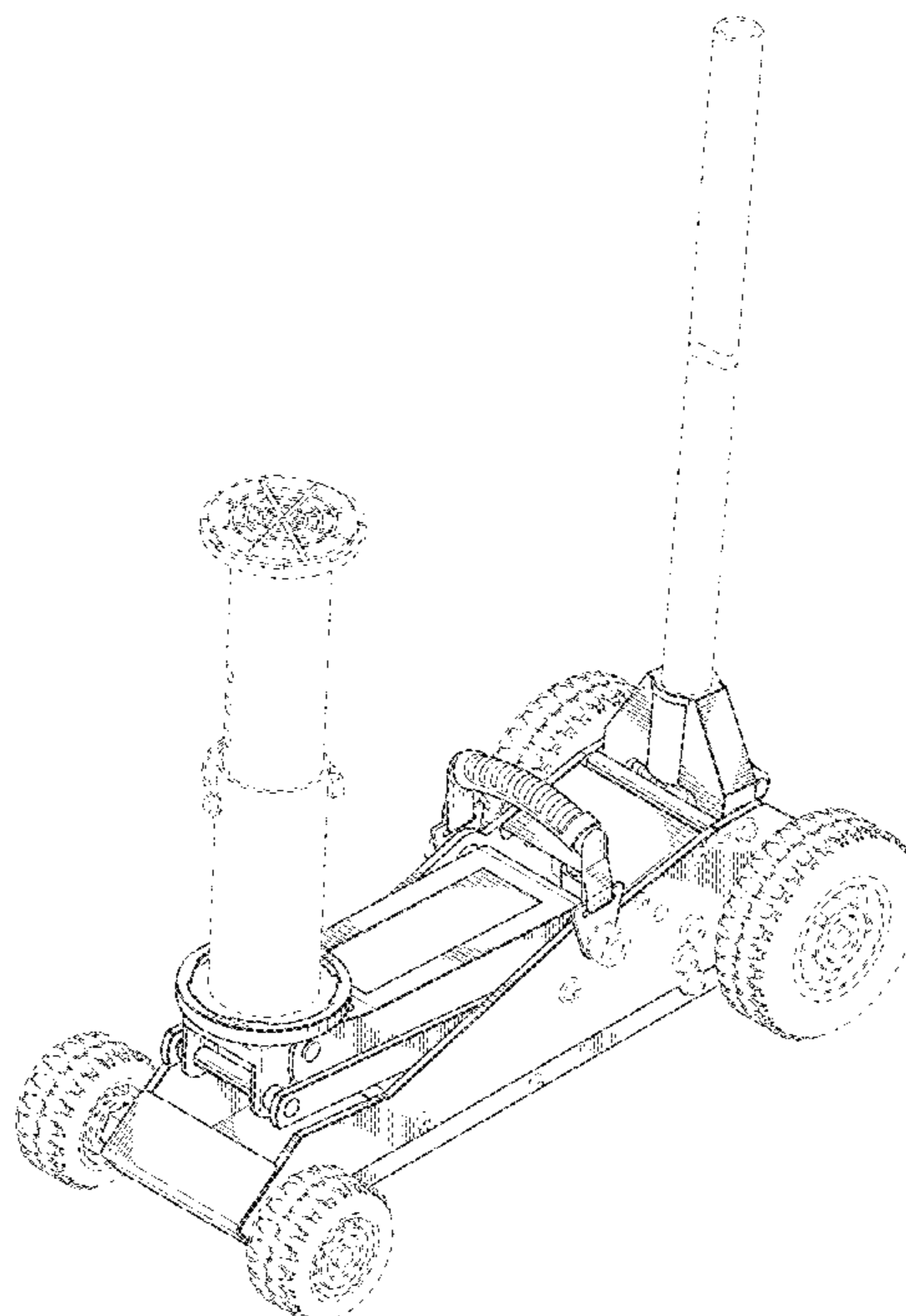
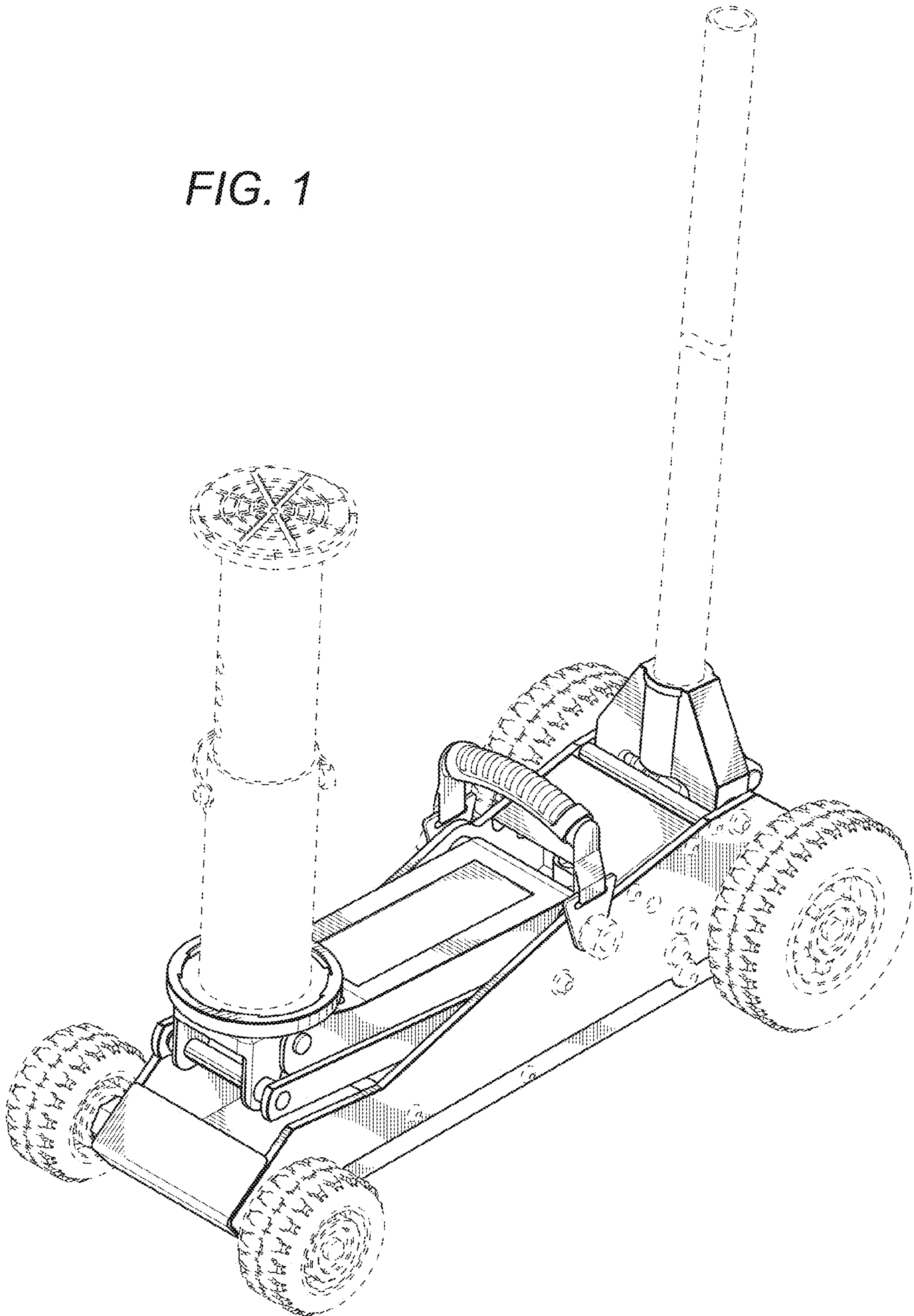

FIG. 1



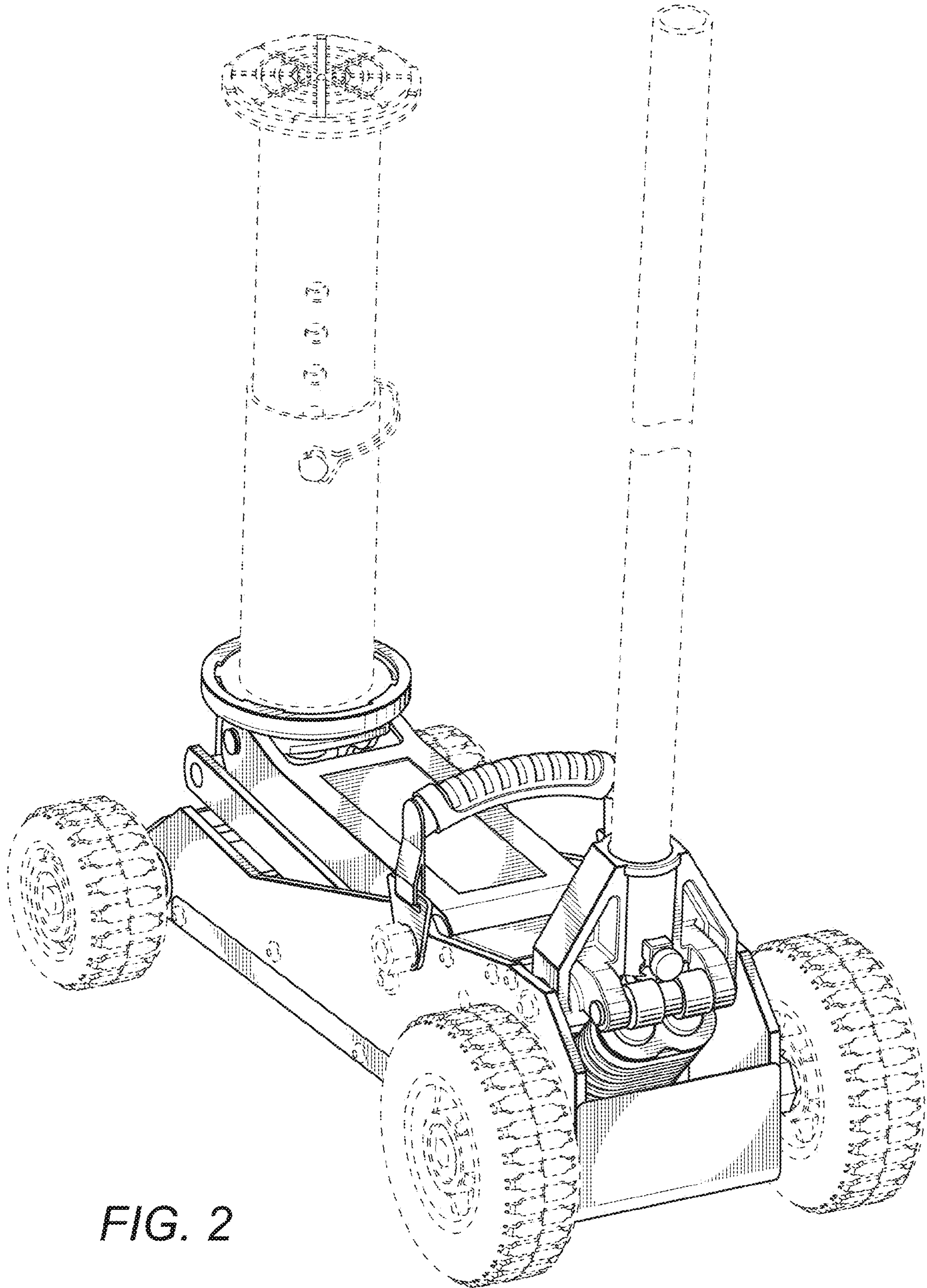

FIG. 2

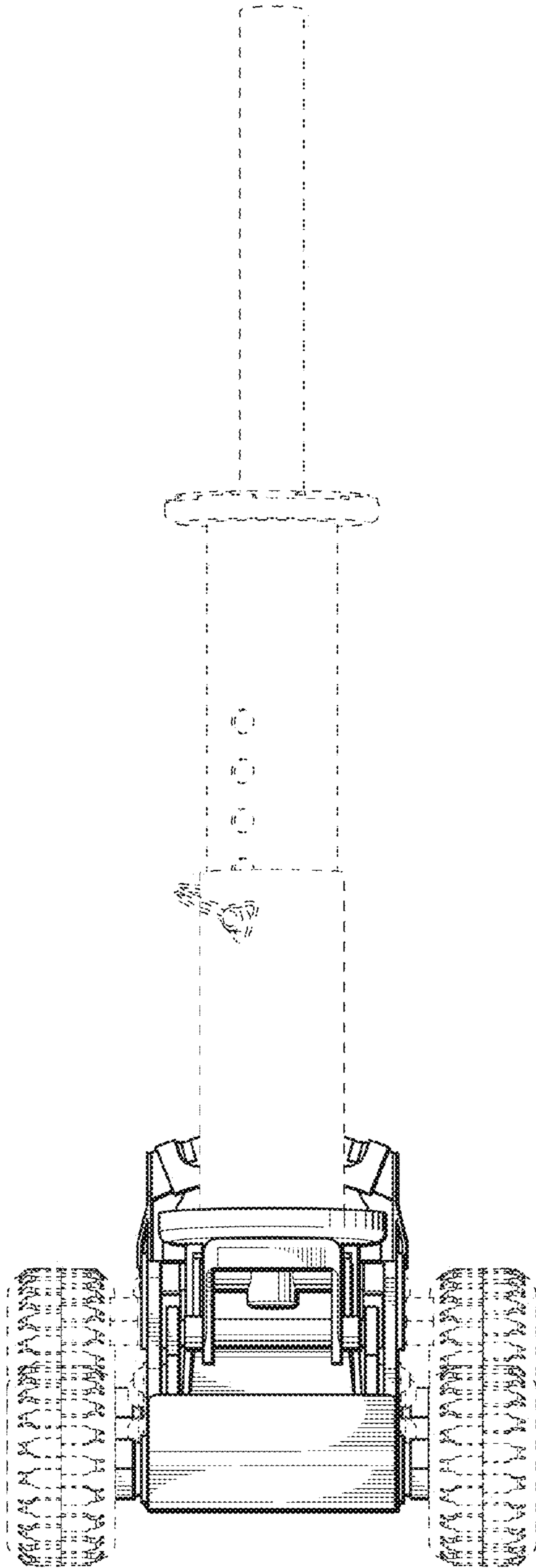

FIG. 3

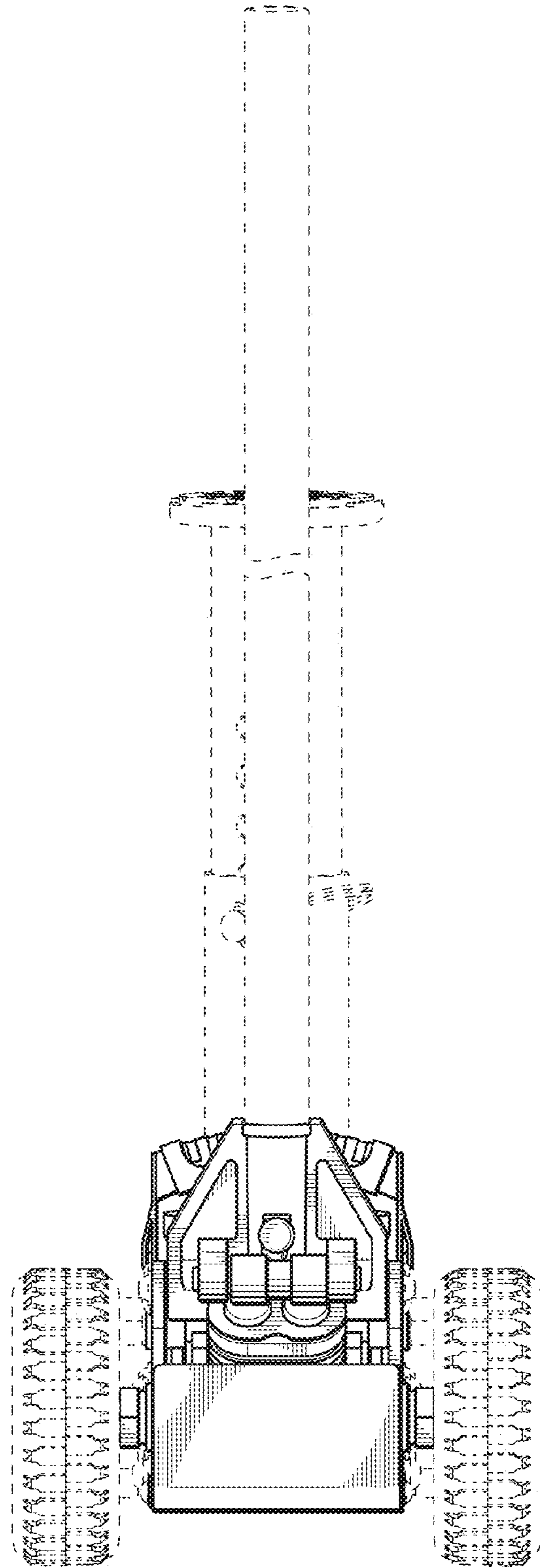

FIG. 4

FIG. 5

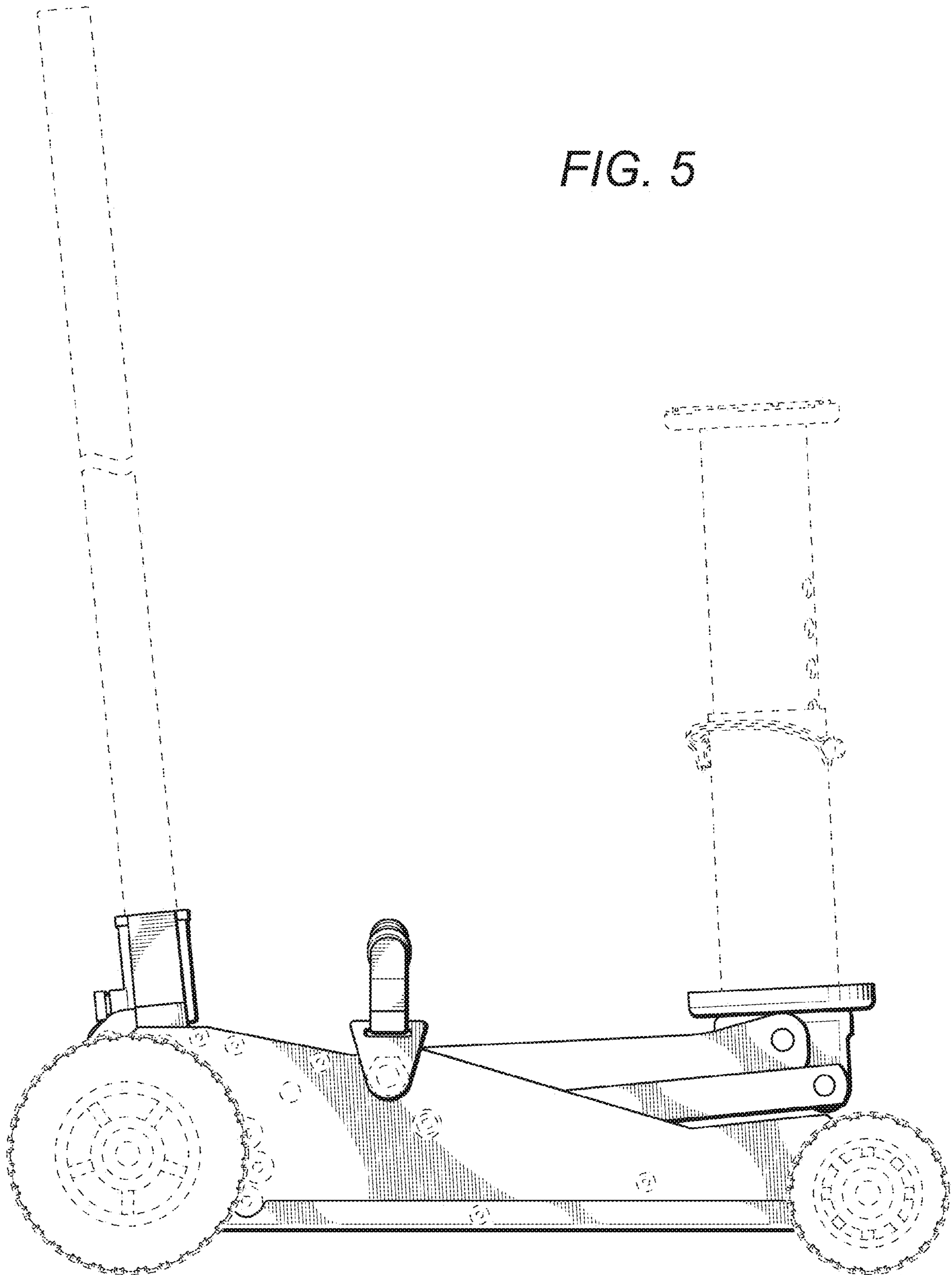
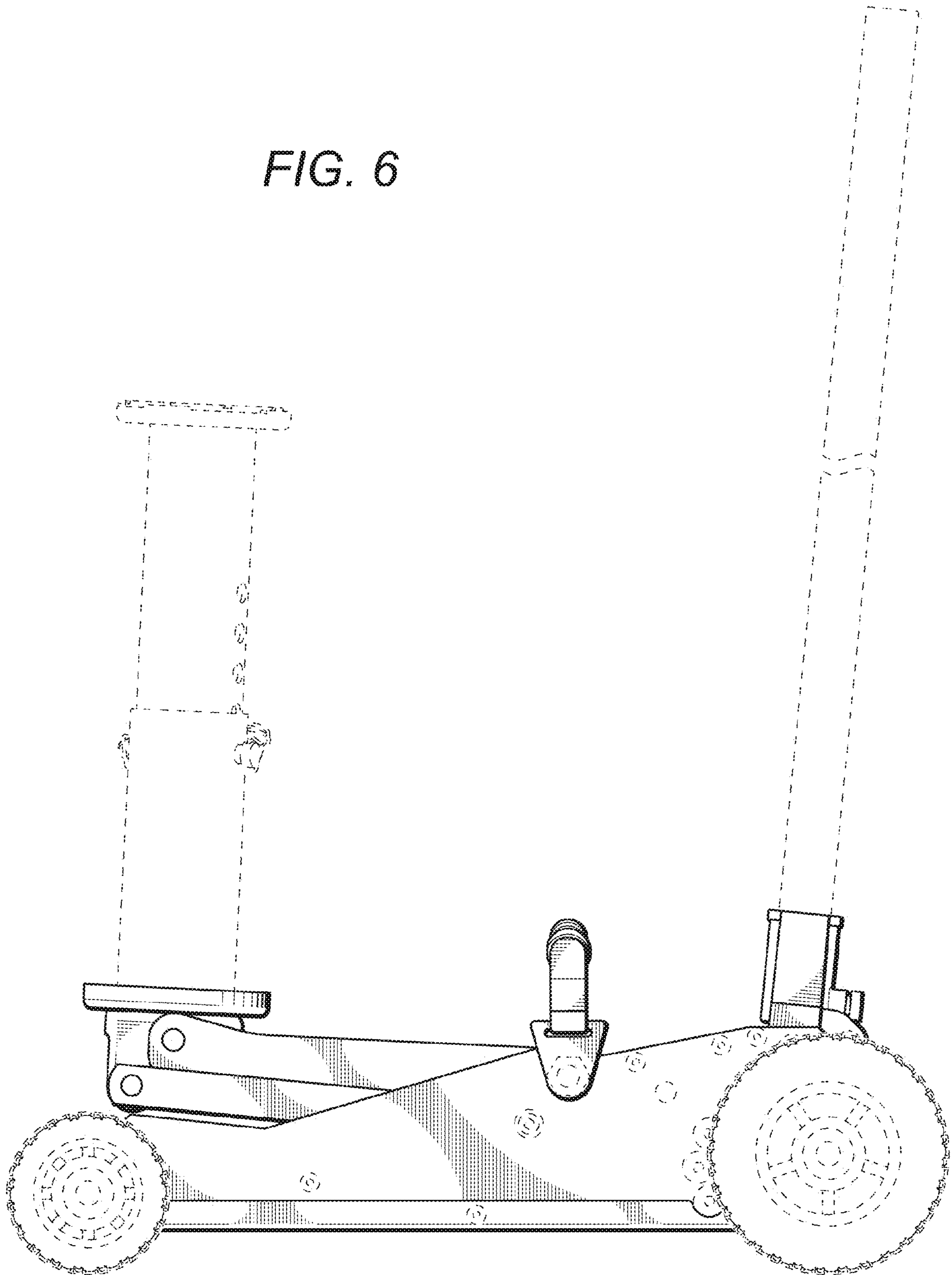

FIG. 6



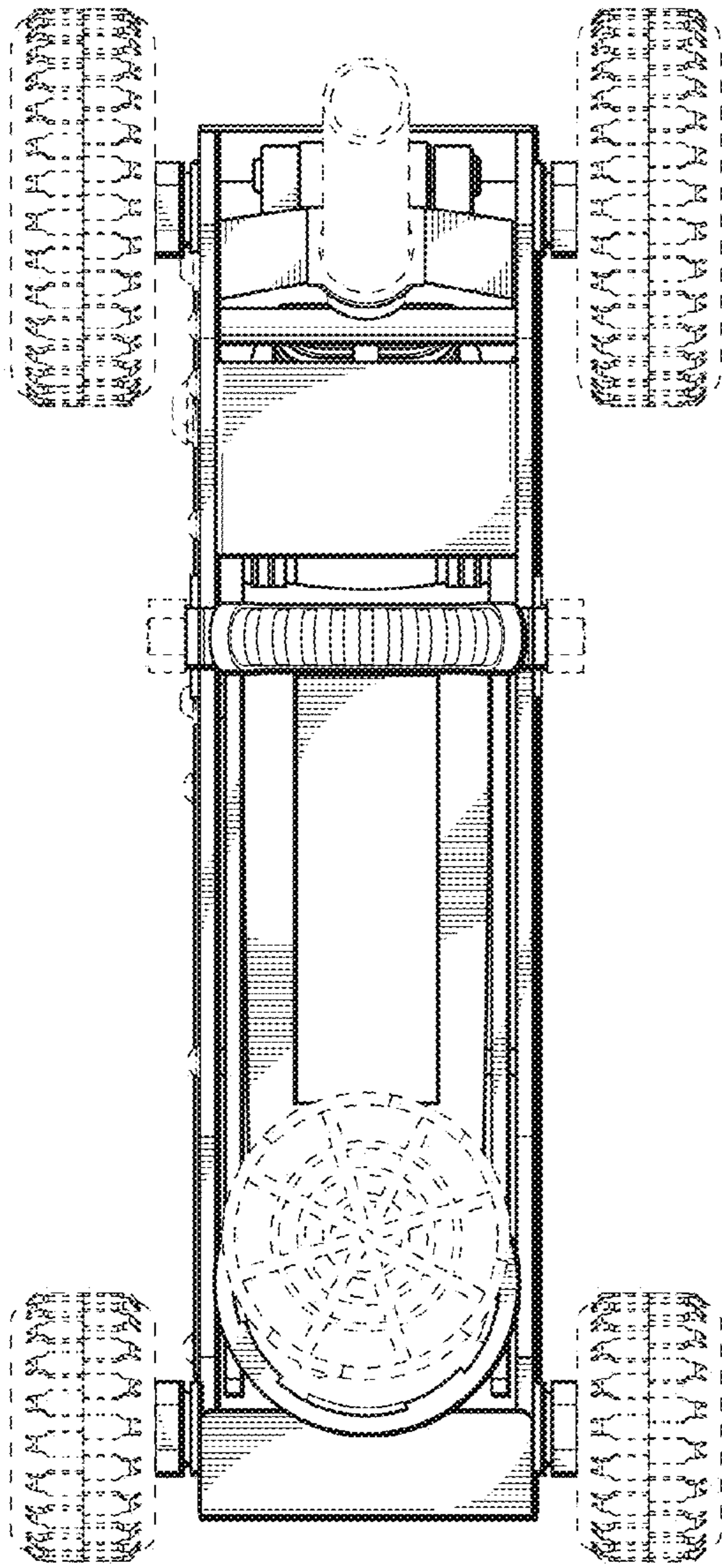

FIG. 7

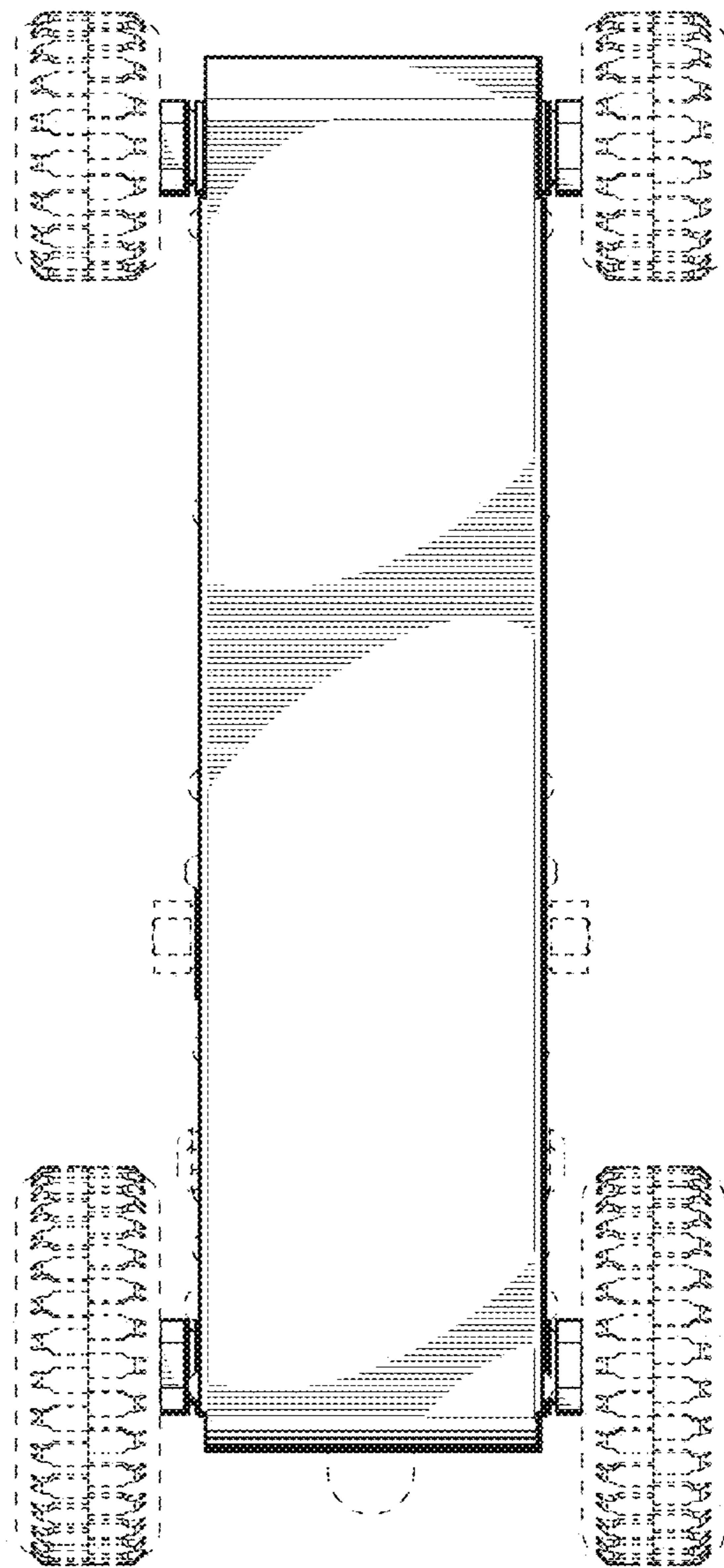

FIG. 8