



US00D962315S

(12) **United States Design Patent**
Hoshi et al.

(10) **Patent No.:** **US D962,315 S**

(45) **Date of Patent:** **** Aug. 30, 2022**

(54) **ELECTRIC ACTUATOR**

(71) Applicant: **SMC CORPORATION**, Tokyo (JP)

(72) Inventors: **Naoki Hoshi**, Matsudo (JP); **Masaki Miyahara**, Moriya (JP); **Ryosuke Sato**, Moriya (JP)

(73) Assignee: **SMC CORPORATION**, Tokyo (JP)

(**) Term: **15 Years**

(21) Appl. No.: **29/737,952**

(22) Filed: **Jun. 12, 2020**

(30) **Foreign Application Priority Data**

Dec. 20, 2019 (CN) 201930715026.8

(51) **LOC (13) Cl.** **15-09**

(52) **U.S. Cl.**
USPC **D15/143**

(58) **Field of Classification Search**
USPC D13/158, 160, 162, 164, 171, 174, 184,
D13/101, 123; D15/143, 148, 149
(Continued)

(56) **References Cited**

U.S. PATENT DOCUMENTS

D333,666 S 3/1993 Kawashima et al.
D399,491 S * 10/1998 Nagai D13/158
(Continued)

Primary Examiner — Michael C Stout

Assistant Examiner — Fitzgerald L Butac

(74) *Attorney, Agent, or Firm* — Birch, Stewart, Kolasch & Birch, LLP

(57) **CLAIM**

The ornamental design for an electric actuator, as shown and described.

DESCRIPTION

FIG. 1 is a front, top and left side perspective view of an electric actuator showing a first embodiment of our new design;

FIG. 2 is a rear, bottom and right side perspective view thereof;

FIG. 3 is a front view thereof;

FIG. 4 is a rear view thereof;

FIG. 5 is a top plan view thereof;

FIG. 6 is a bottom plan view thereof;

FIG. 7 is a left side view thereof;

FIG. 8 is a right side view thereof;

FIG. 9 is a front, top and left side perspective view of an electric actuator showing a second embodiment of our new design;

FIG. 10 is a rear, bottom and right side perspective view of FIG. 9;

FIG. 11 is a front view of FIG. 9;

FIG. 12 is a rear view of FIG. 9;

FIG. 13 is a top plan view of FIG. 9;

FIG. 14 is a bottom plan view of FIG. 9;

FIG. 15 is a left side view of FIG. 9;

FIG. 16 is a right side view of FIG. 9;

FIG. 17 is a front, top and left side perspective view of an electric actuator showing a third embodiment of our new design;

FIG. 18 is a rear, bottom and right side perspective view of FIG. 17;

FIG. 19 is a front view of FIG. 17;

FIG. 20 is a rear view of FIG. 17;

FIG. 21 is a top plan view of FIG. 17;

FIG. 22 is a bottom plan view of FIG. 17;

FIG. 23 is a left side view of FIG. 17;

FIG. 24 is a right side view of FIG. 17;

FIG. 25 is a front, top and left side perspective view of an electric actuator showing a fourth embodiment of our new design;

FIG. 26 is a rear, bottom and right side perspective view of FIG. 25;

FIG. 27 is a front view of FIG. 25;

FIG. 28 is a rear view of FIG. 25;

FIG. 29 is a top plan view of FIG. 25;

FIG. 30 is a bottom plan view of FIG. 25;

FIG. 31 is a left side view of FIG. 25;

FIG. 32 is a right side view of FIG. 25;

(Continued)

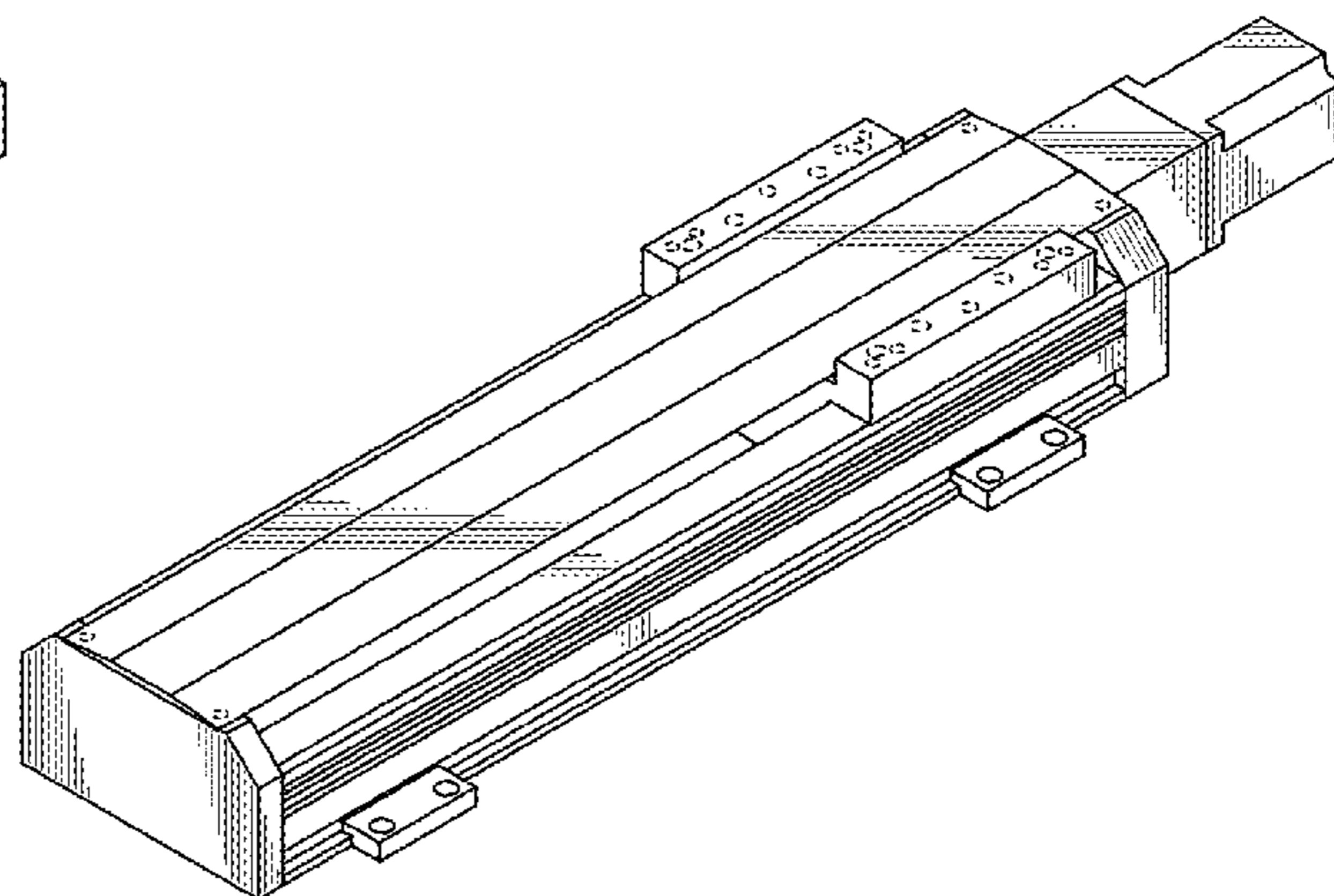
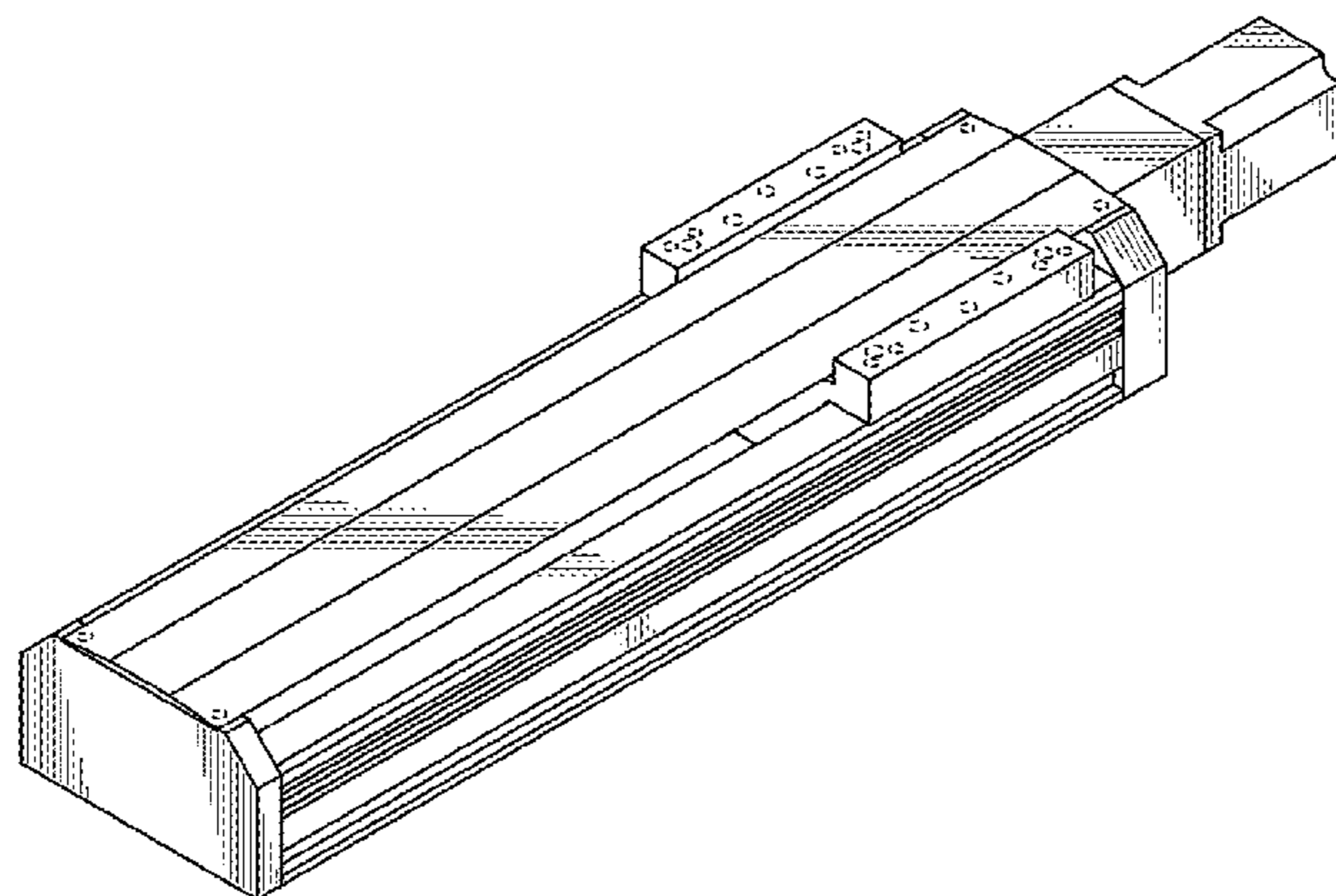

FIG. 33 is a front, top and left side perspective view of an electric actuator showing a fifth embodiment of our new design;
 FIG. 34 is a rear, bottom and right side perspective view of FIG. 33;
 FIG. 35 is a front view of FIG. 33;
 FIG. 36 is a rear view of FIG. 33;
 FIG. 37 is a top plan view of FIG. 33;
 FIG. 38 is a bottom plan view of FIG. 33;
 FIG. 39 is a left side view of FIG. 33;
 FIG. 40 is a right side view of FIG. 33;
 FIG. 41 is a front, top and left side perspective view of an electric actuator showing a sixth embodiment of our new design;
 FIG. 42 is a rear, bottom and right side perspective view of FIG. 41;
 FIG. 43 is a front view of FIG. 41;
 FIG. 44 is a rear view of FIG. 41;
 FIG. 45 is a top plan view of FIG. 41;
 FIG. 46 is a bottom plan view of FIG. 41;
 FIG. 47 is a left side view of FIG. 41; and,
 FIG. 48 is a right side view of FIG. 41.
 The broken lines depict portions of the electric actuator that form no part of the claimed design.

1 Claim, 48 Drawing Sheets

(58) **Field of Classification Search**

CPC H02K 33/02; H02K 33/12
 See application file for complete search history.

(56)

References Cited

U.S. PATENT DOCUMENTS

D399,830	S	*	10/1998	Nagai	D13/199
D412,917	S	*	8/1999	Nagai	D15/199
D413,129	S	*	8/1999	Nagai	D15/199
6,336,390	B1	*	1/2002	Sato	F15B 15/1404 91/409
6,490,961	B2	*	12/2002	Sato	F15B 15/1404 91/406
6,807,877	B2	*	10/2004	Sato	B23Q 1/58 74/89.32
D578,147	S	*	10/2008	Fukano	D15/143
D589,459	S		3/2009	Iida		
D596,653	S	*	7/2009	Fukano	D15/143
D611,514	S		3/2010	Fukano et al.		
D621,860	S	*	8/2010	Fukano	D13/110
D624,098	S	*	9/2010	Fukano	D15/143
D624,099	S	*	9/2010	Fukano	D15/143
D624,100	S	*	9/2010	Fukano	D15/143
D624,570	S		9/2010	Fukano et al.		
D624,572	S	*	9/2010	Fukano	D15/143
D636,798	S	*	4/2011	Fukano	D15/143
D636,799	S	*	4/2011	Fukano	D15/143
D650,401	S	*	12/2011	Fukano	D15/143
D656,169	S		3/2012	Fukano et al.		
D704,238	S	*	5/2014	Fukano	D15/199
D744,559	S	*	12/2015	Nakayama	D15/143
D784,430	S		4/2017	Liou et al.		
10,385,948	B2	*	8/2019	Nakayama	F16H 25/20
10,487,873	B2	*	11/2019	Nakayama	F16C 29/002
D948,579	S	*	4/2022	Asahara	D15/7
D951,999	S	*	5/2022	Asahara	D15/7

* cited by examiner

FIG. 1

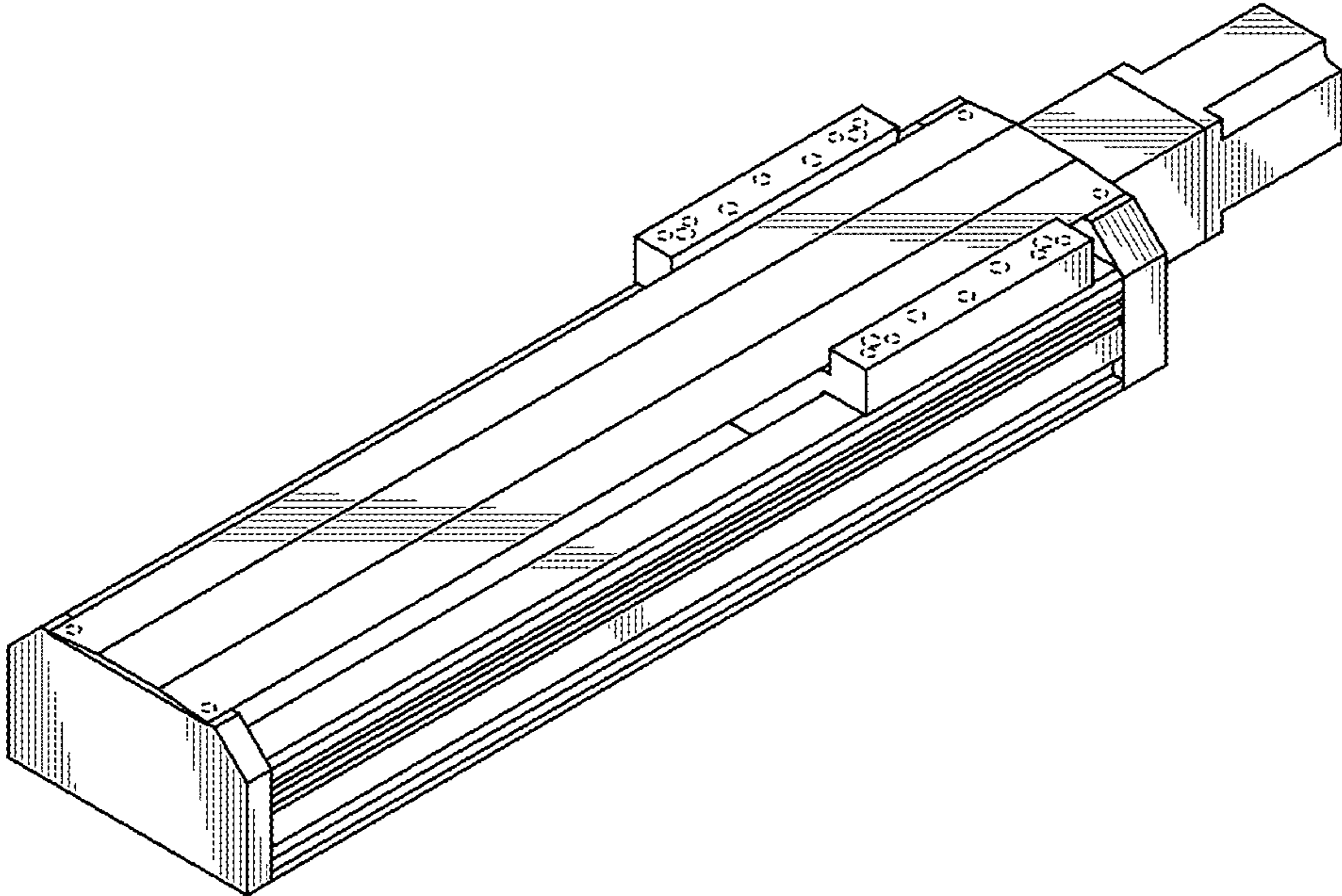

FIG. 2

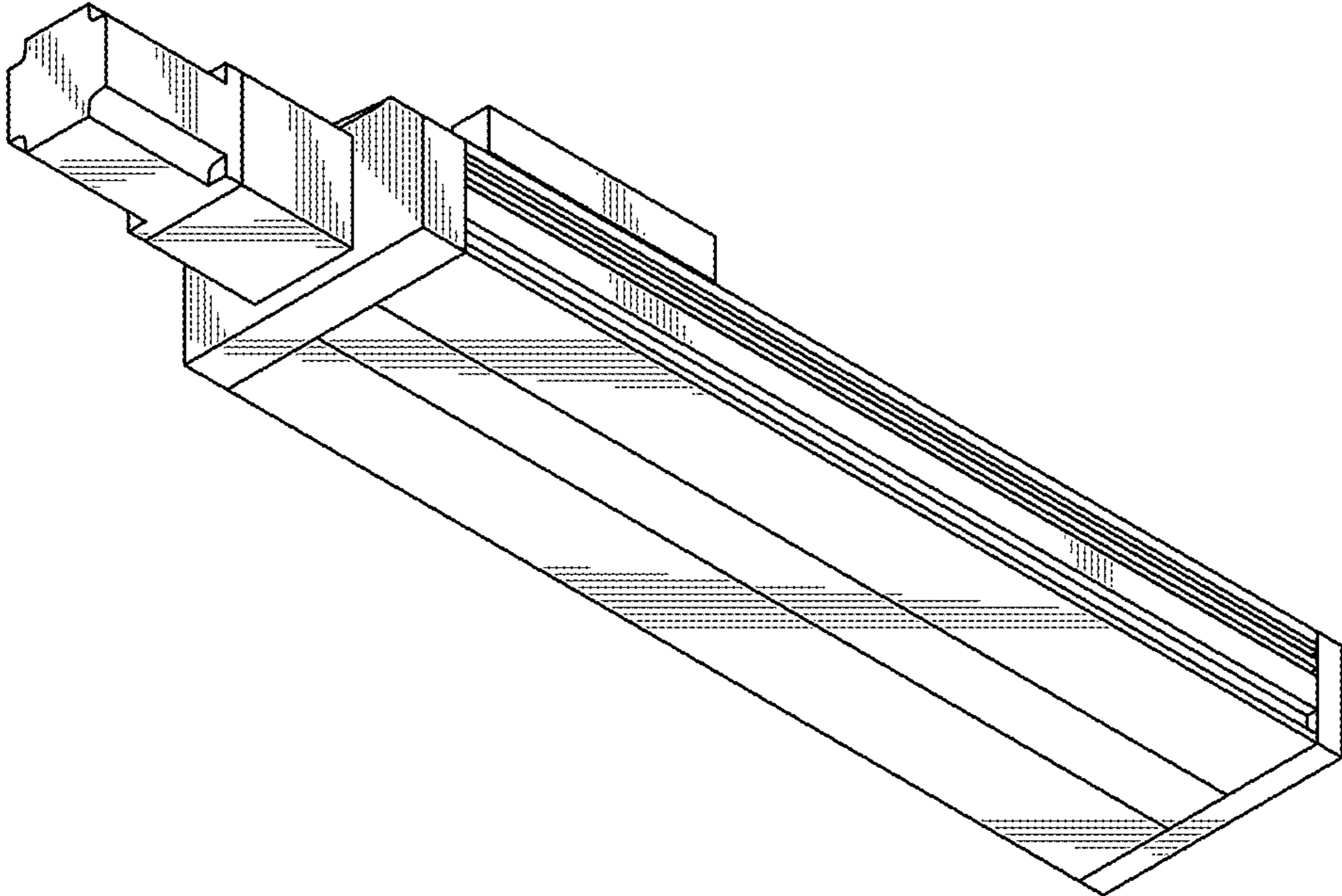

FIG. 3

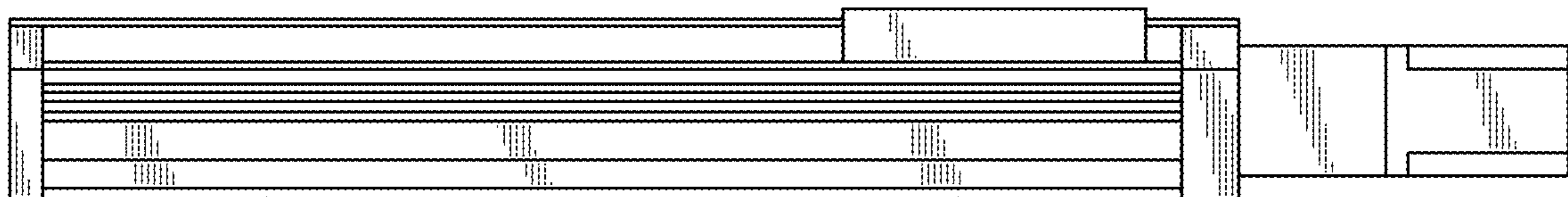

FIG. 4

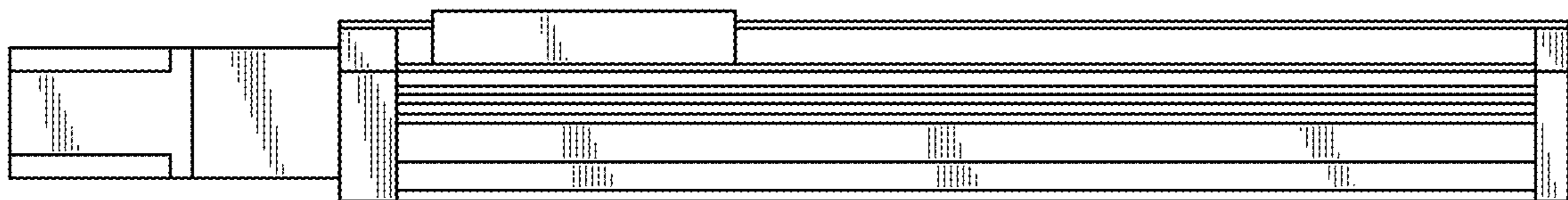

FIG. 5

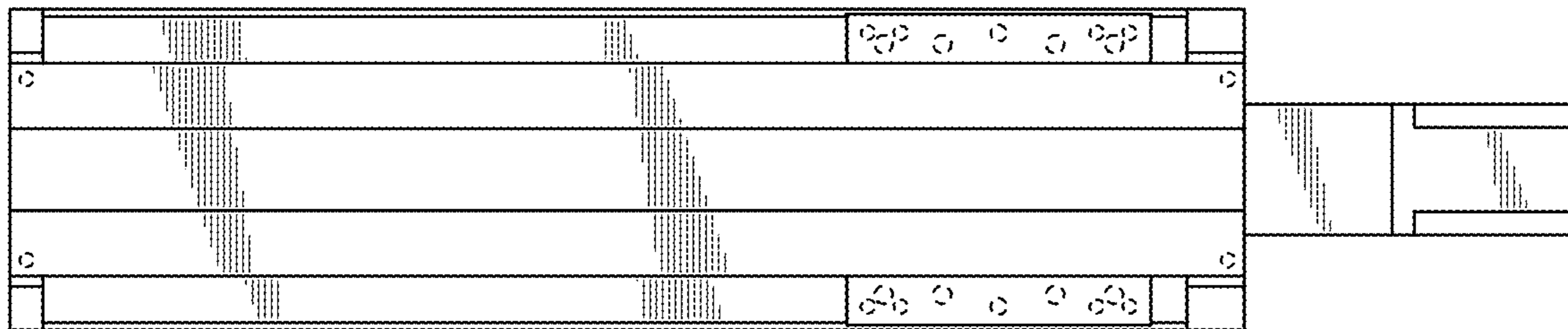

FIG. 6

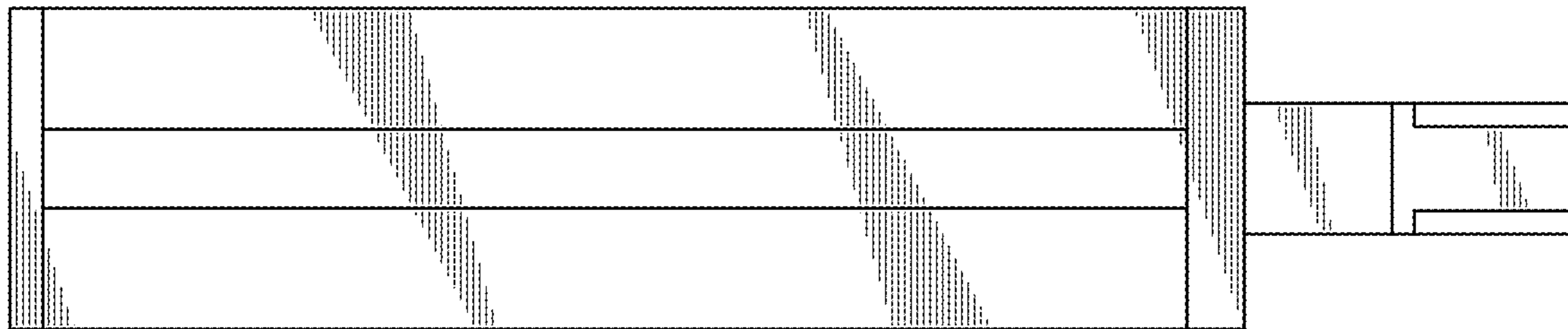

FIG. 7

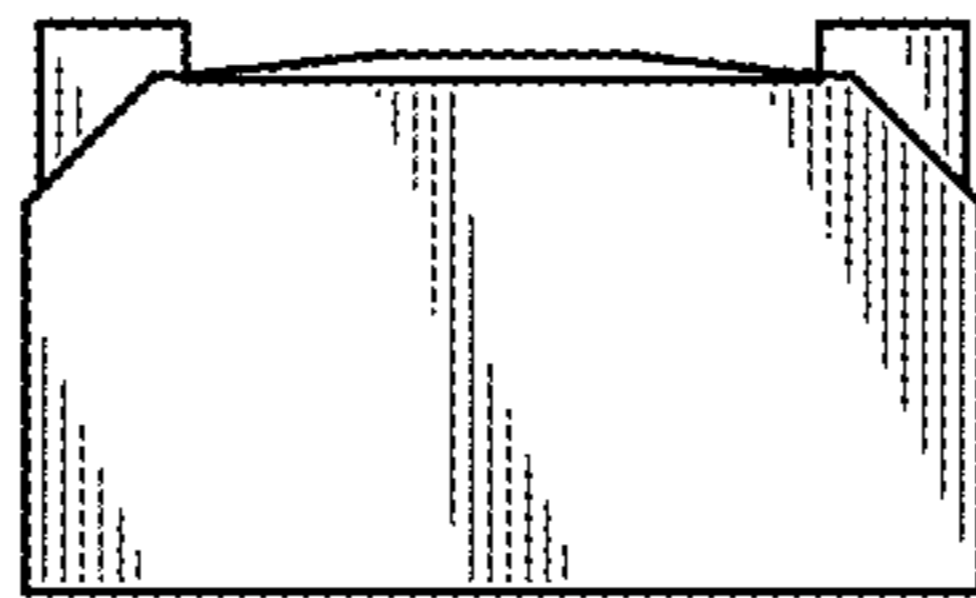

FIG. 8

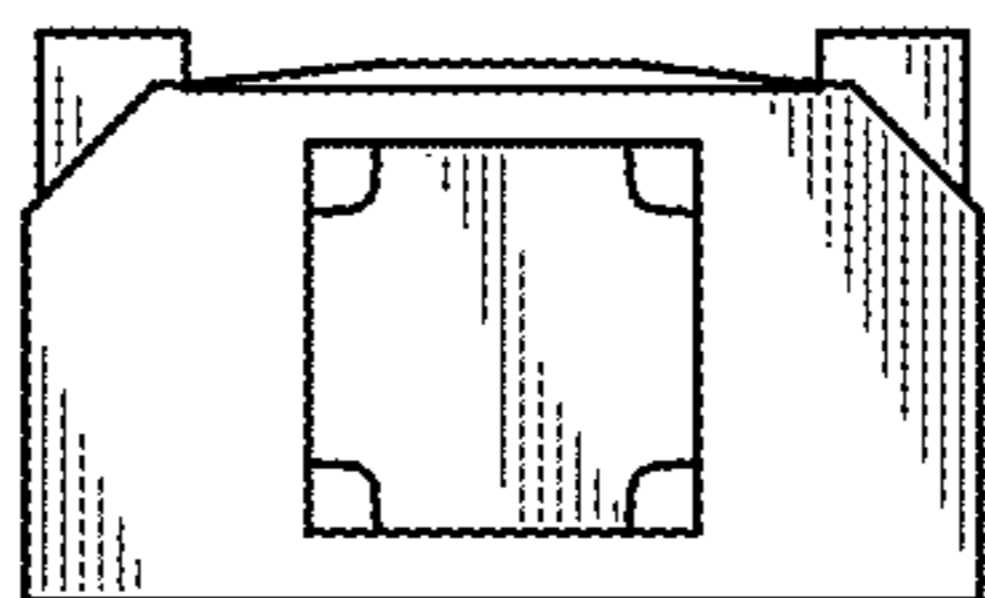

FIG. 9

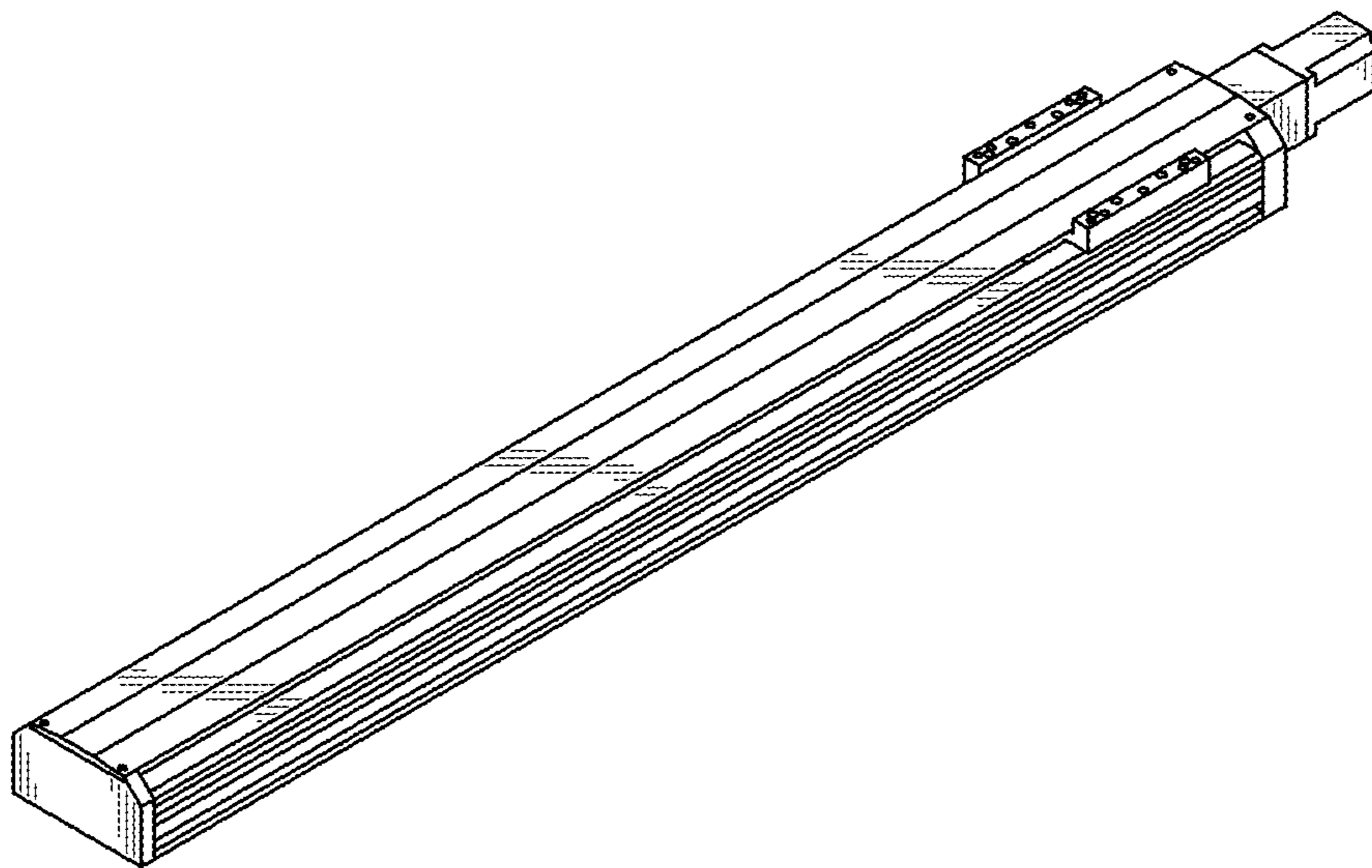

FIG. 10

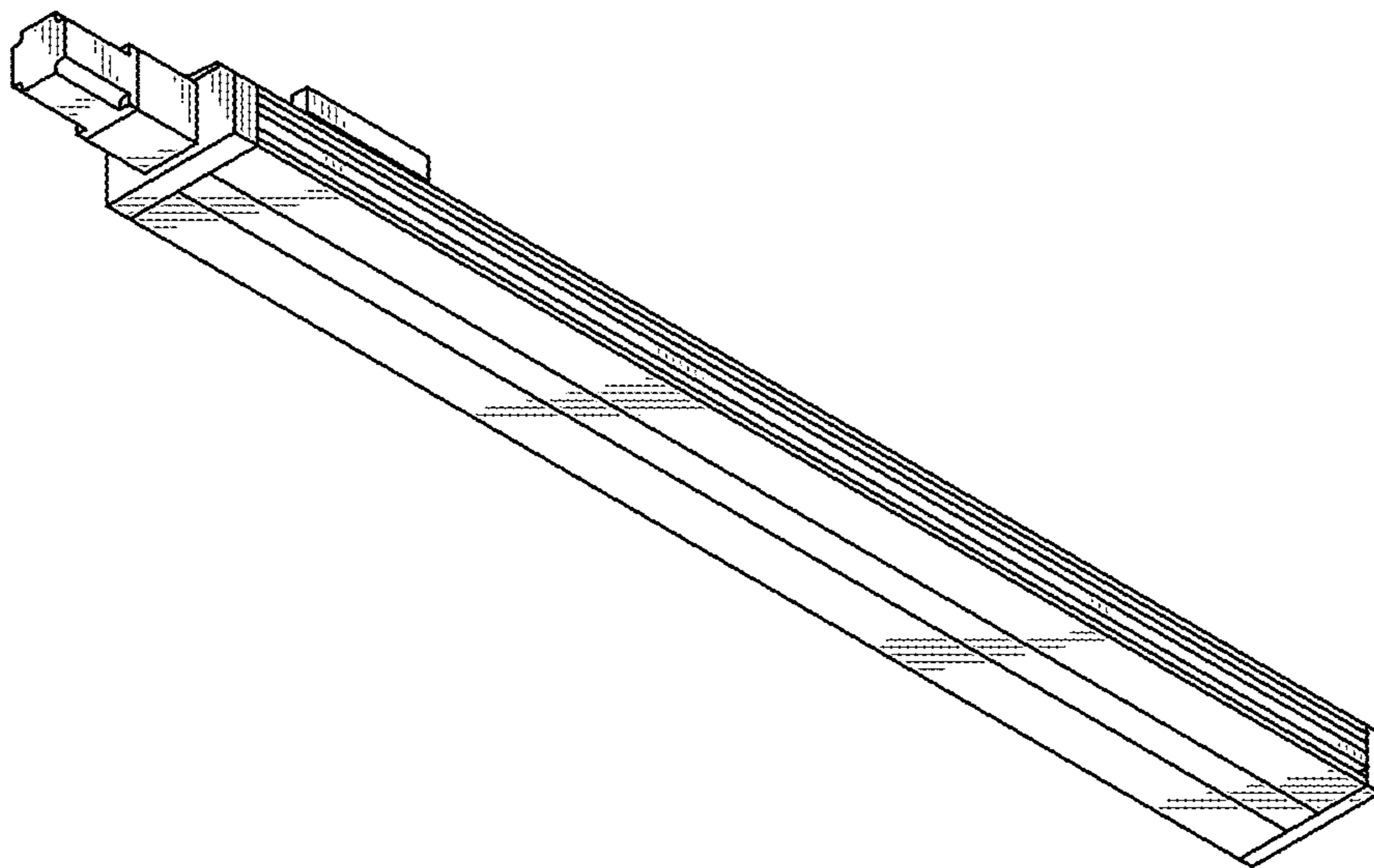

FIG. 11

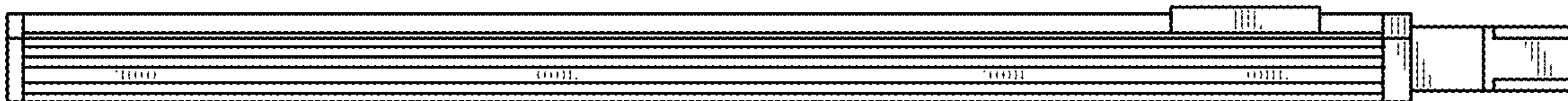

FIG. 12

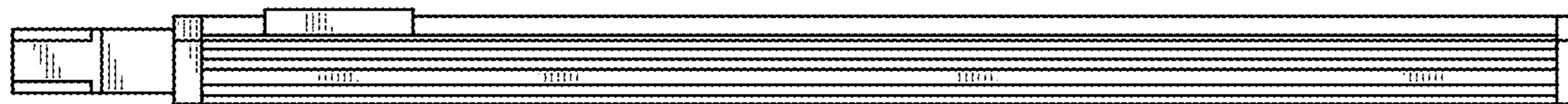

FIG. 13

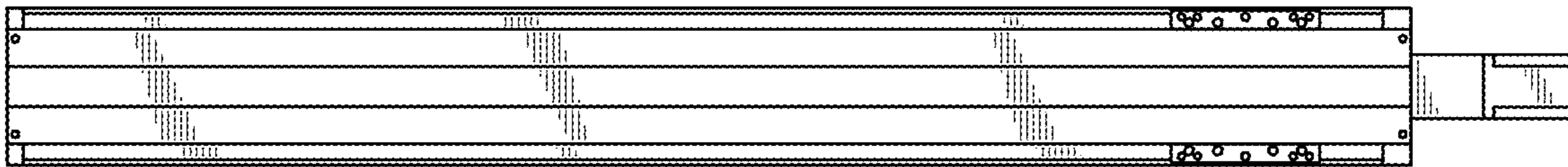

FIG. 14

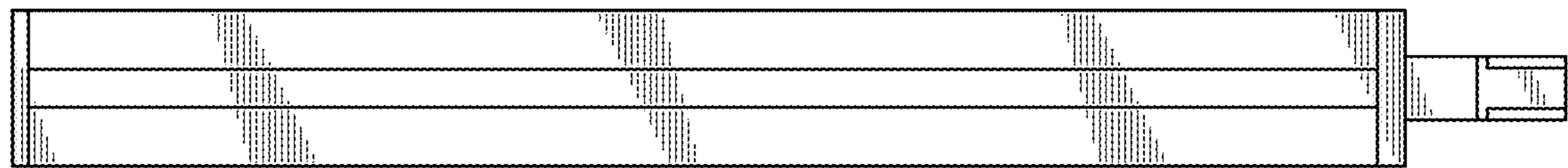

FIG. 15



FIG. 16

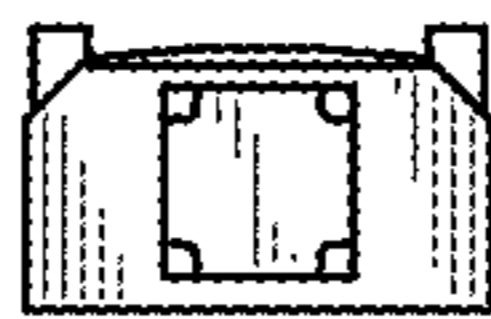

FIG. 17

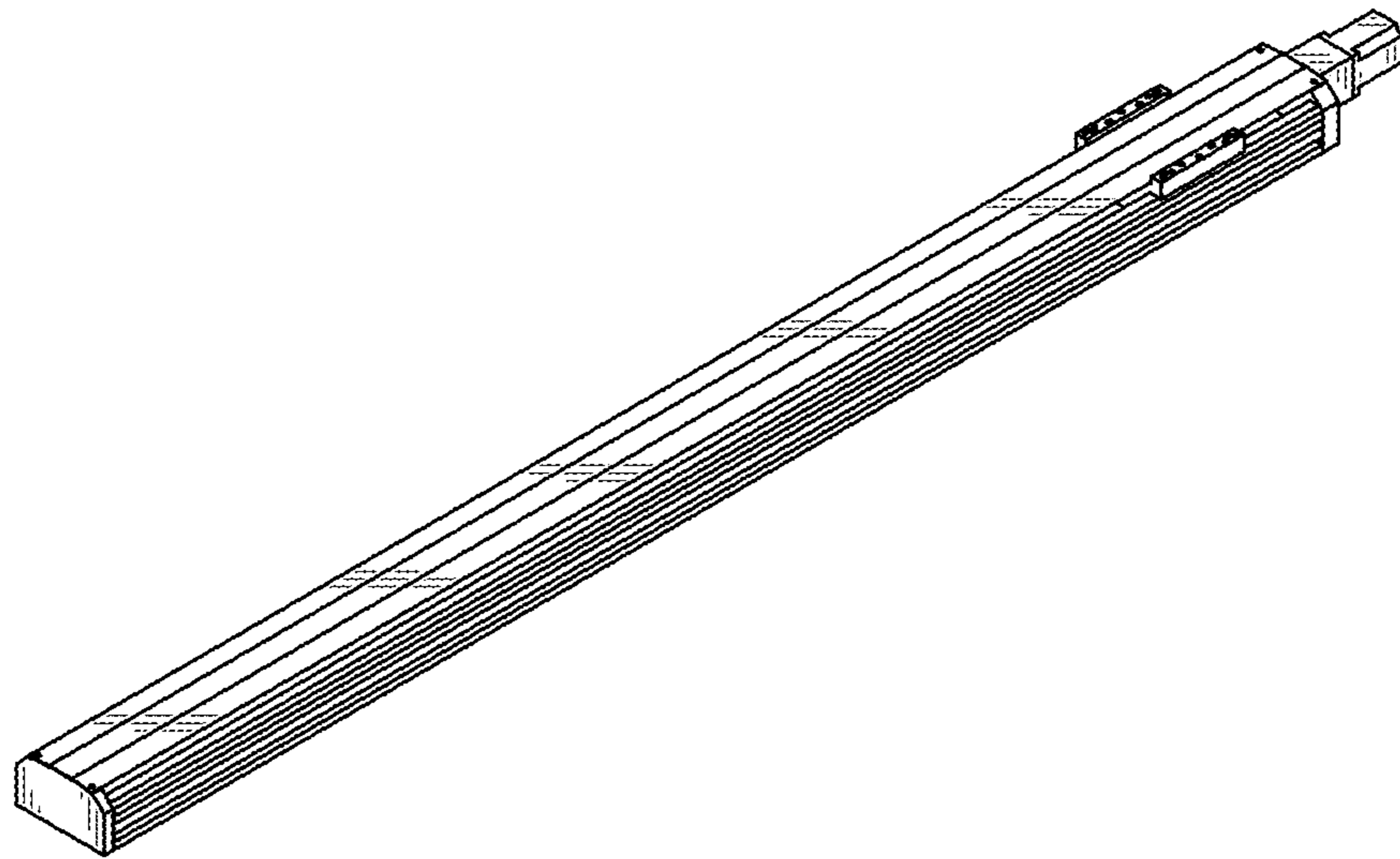

FIG. 18

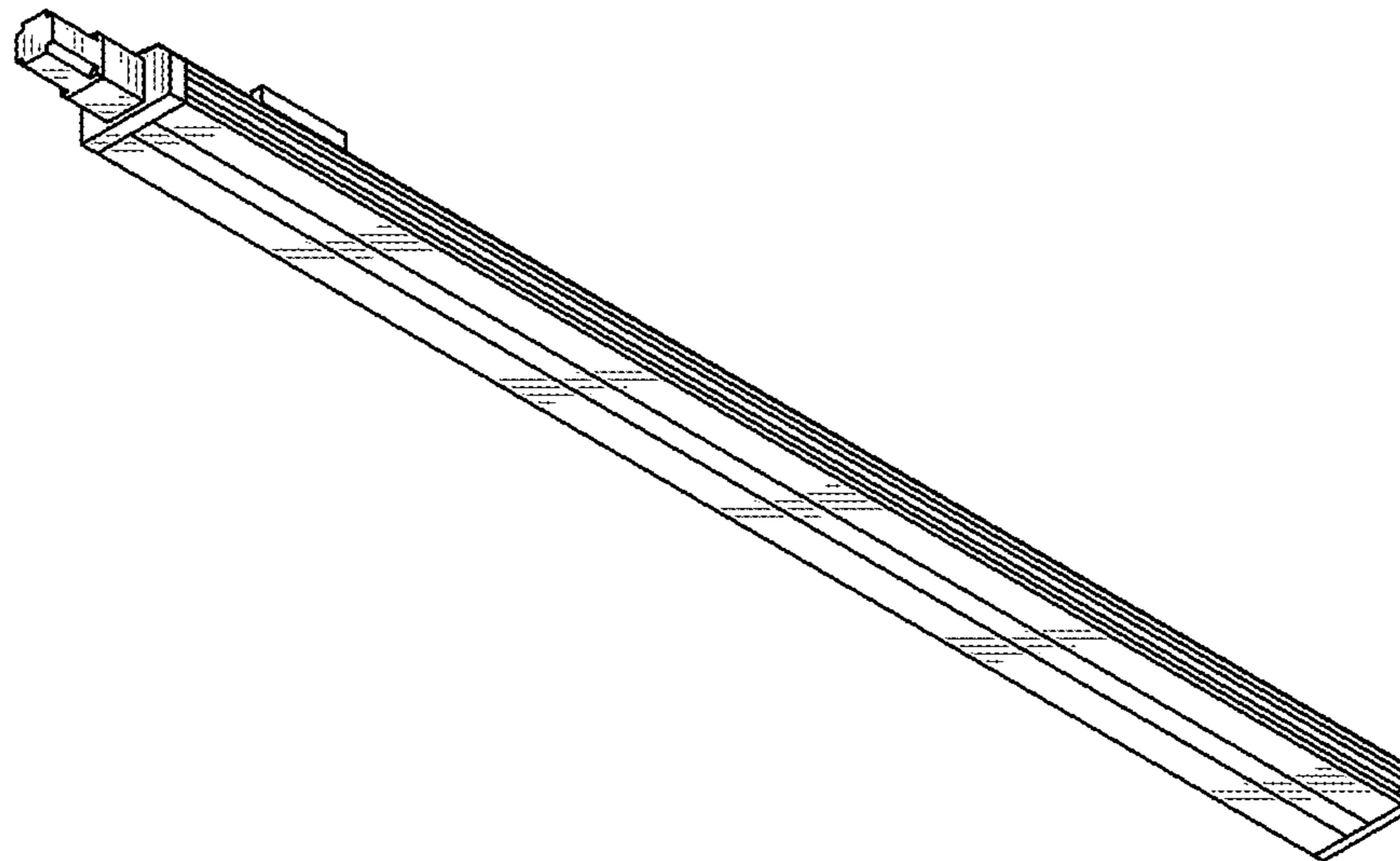

FIG. 19

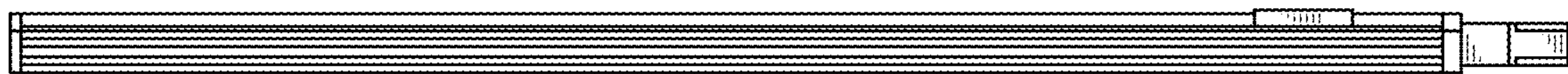

FIG. 20

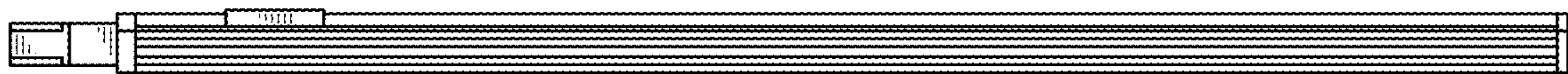

FIG. 21

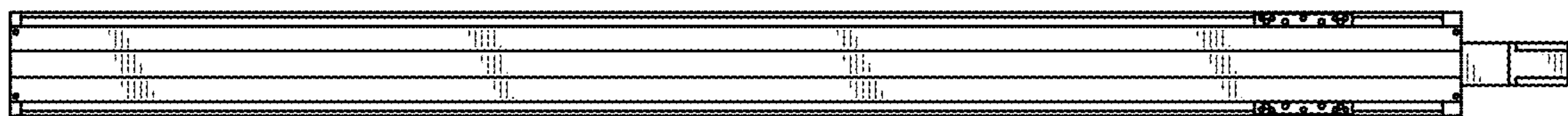

FIG. 22



FIG. 23

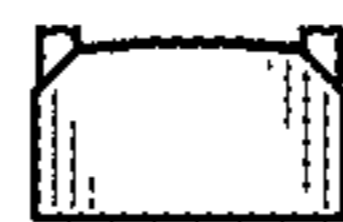

FIG. 24



FIG. 25

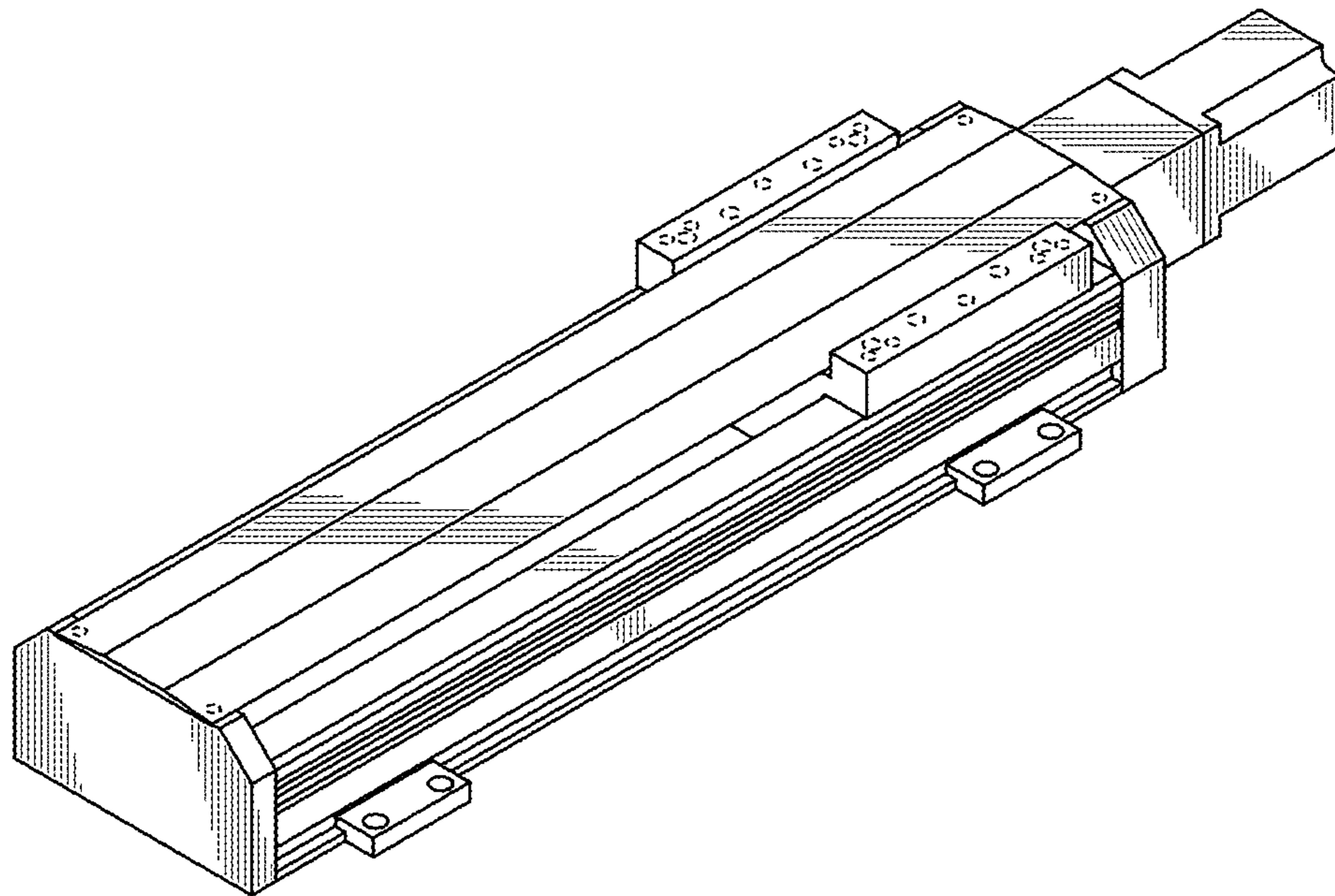

FIG. 26

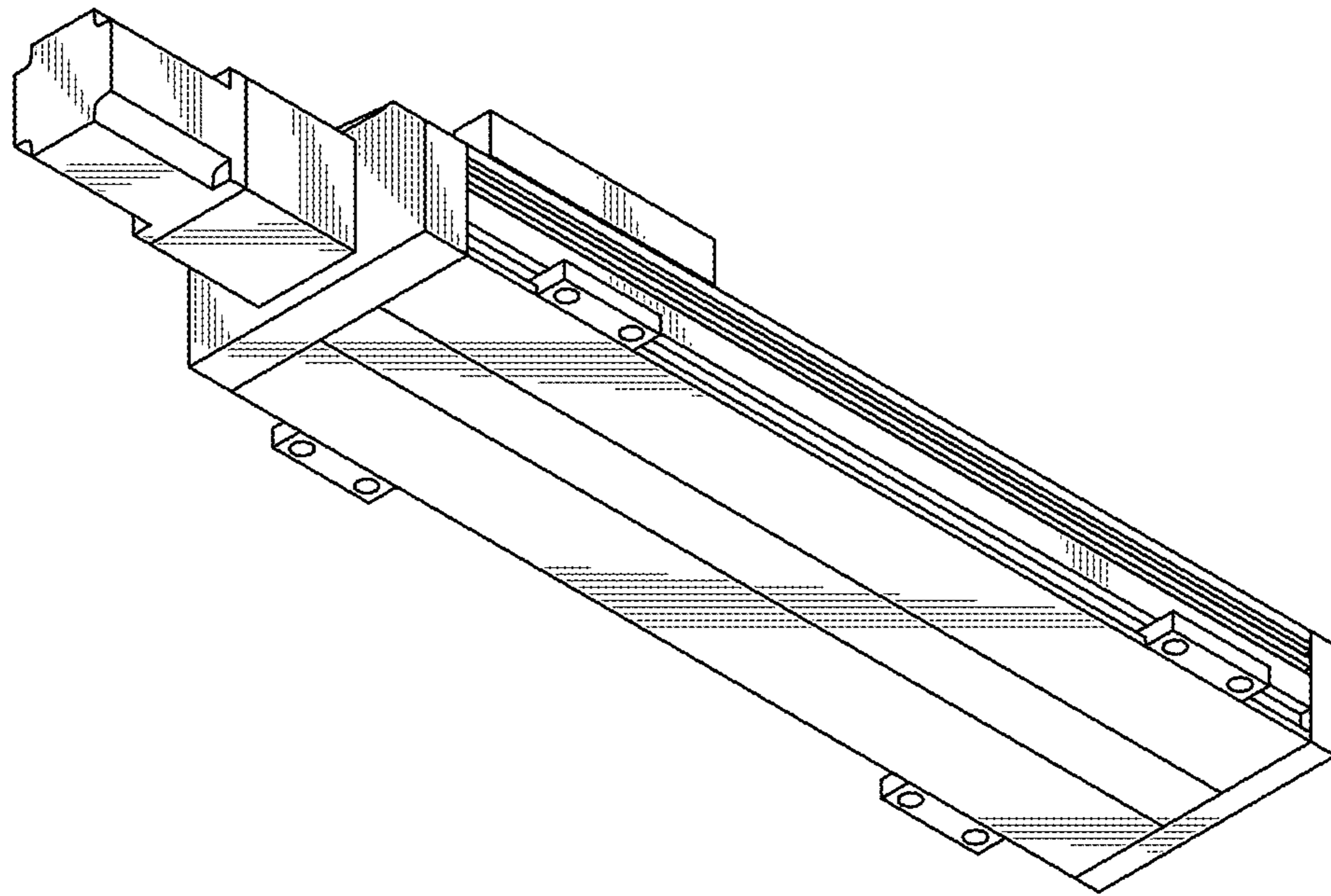

FIG. 27

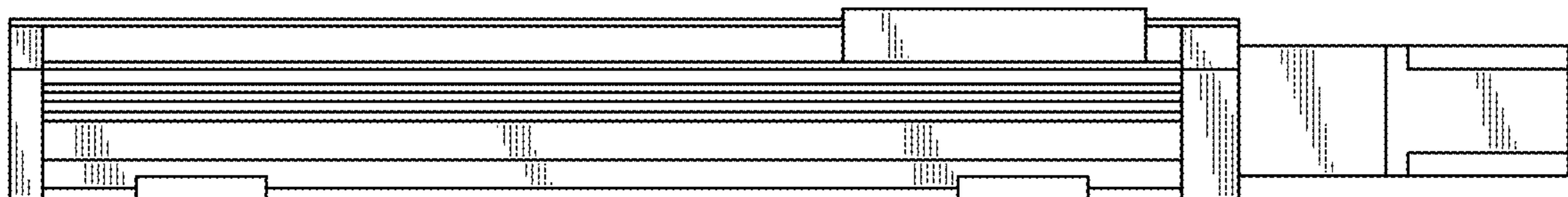

FIG. 28

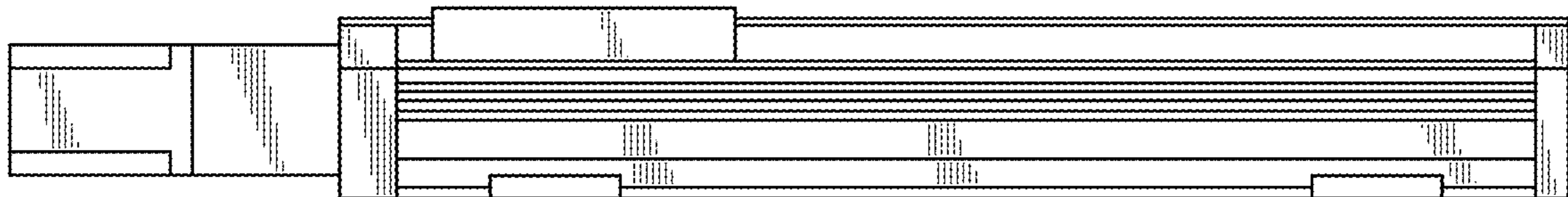

FIG. 29

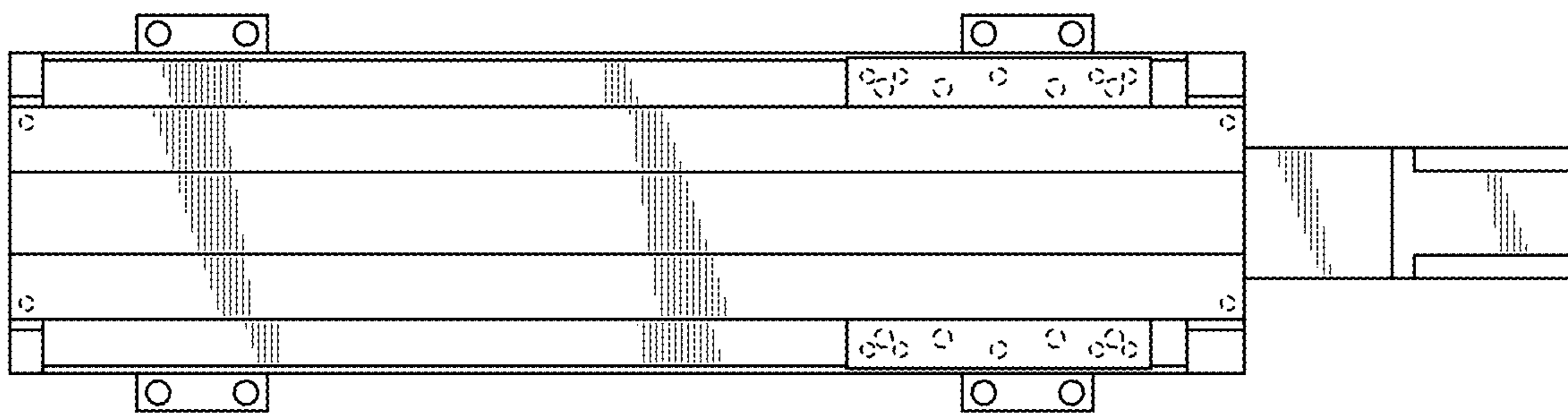

FIG. 30

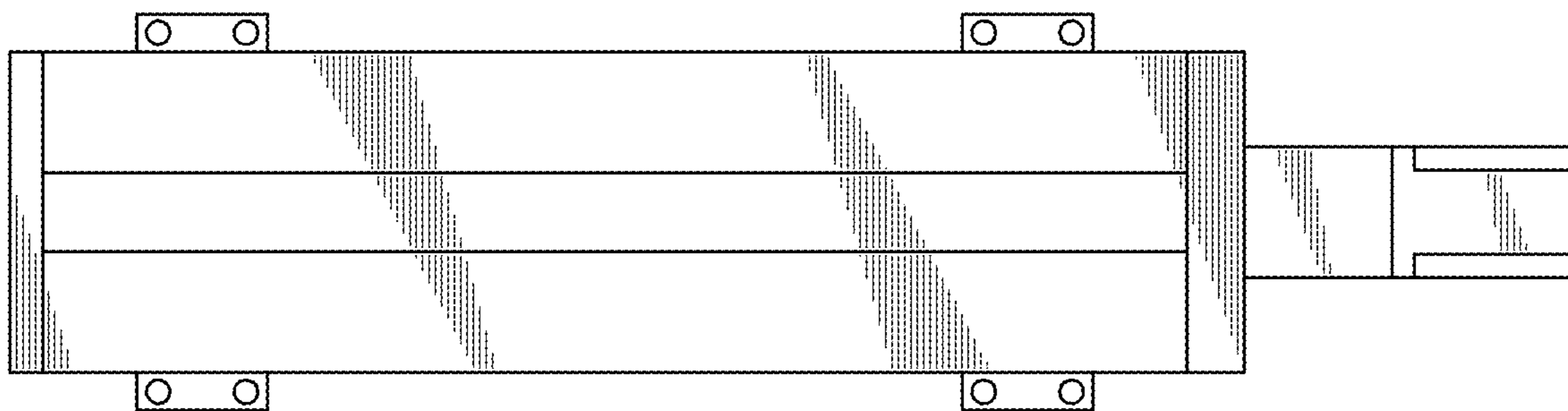

FIG. 31

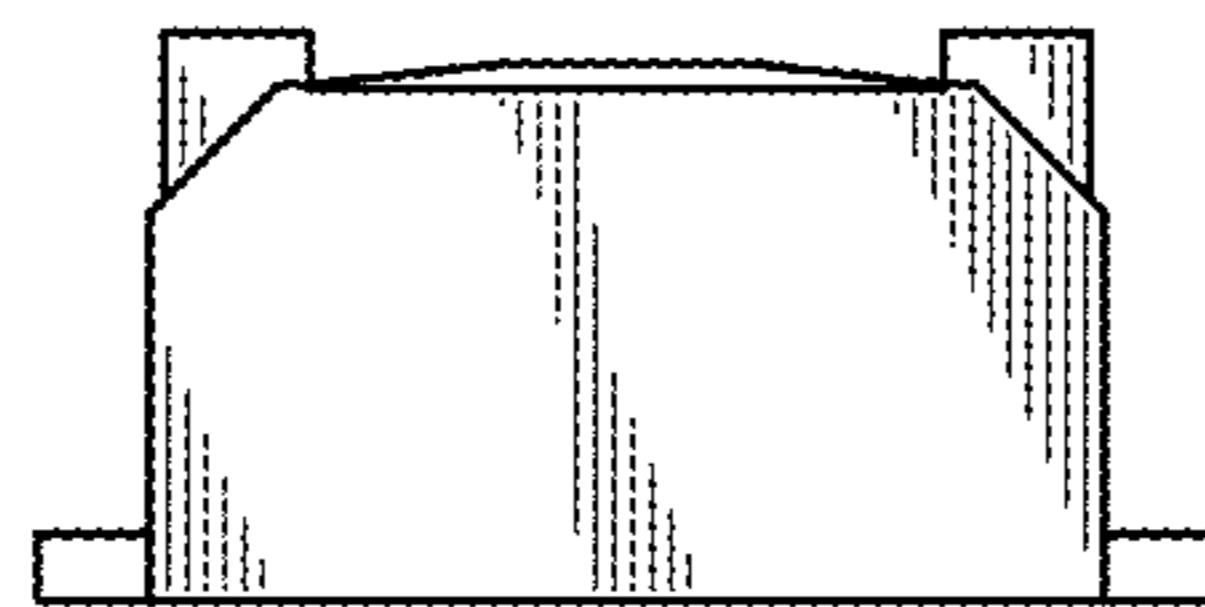

FIG. 32

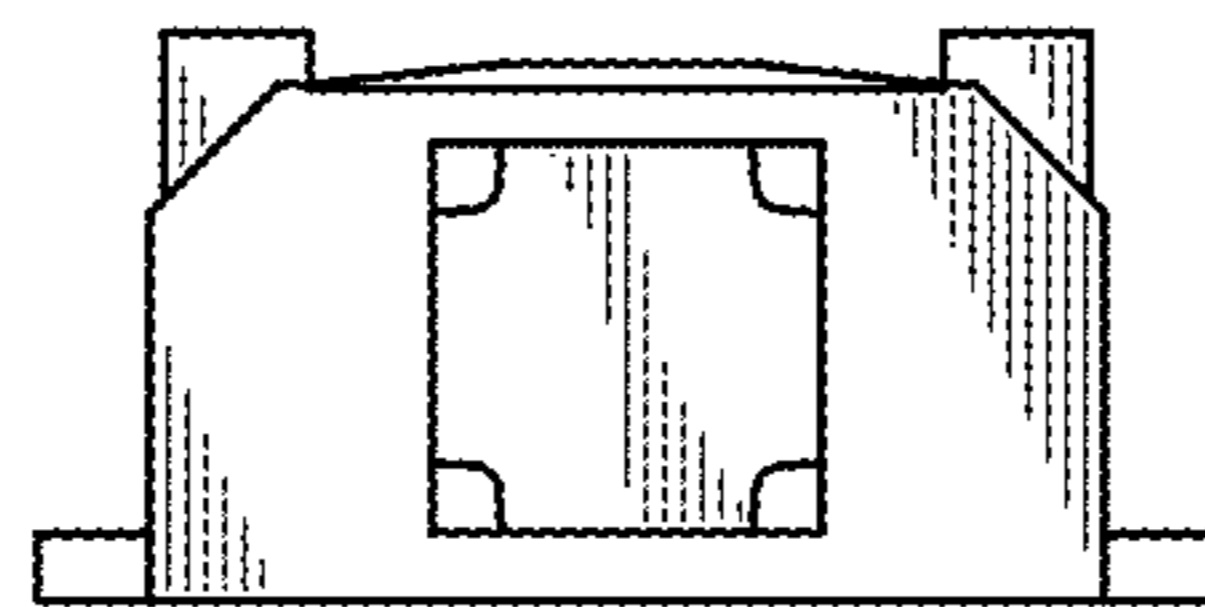

FIG. 33

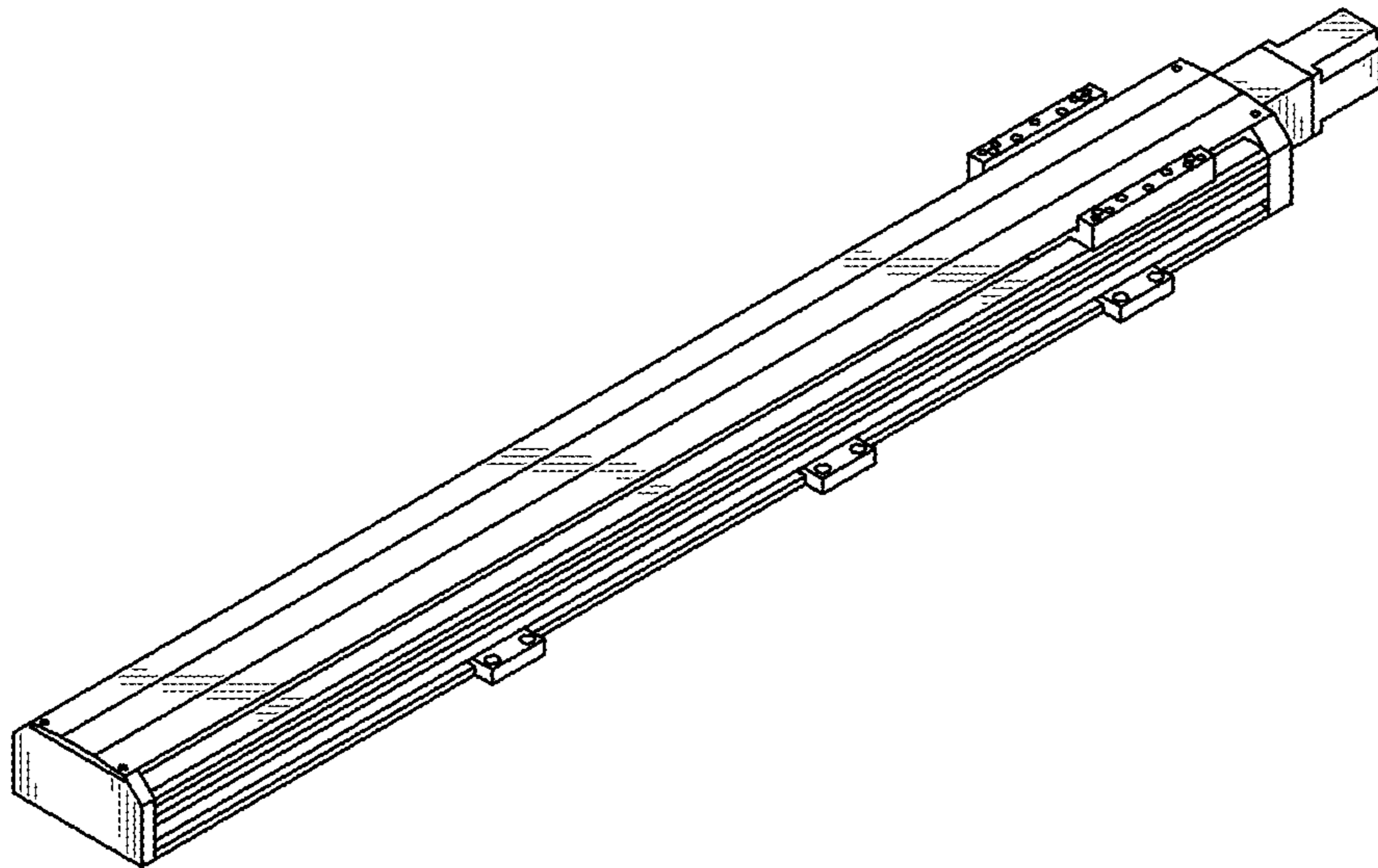

FIG. 34

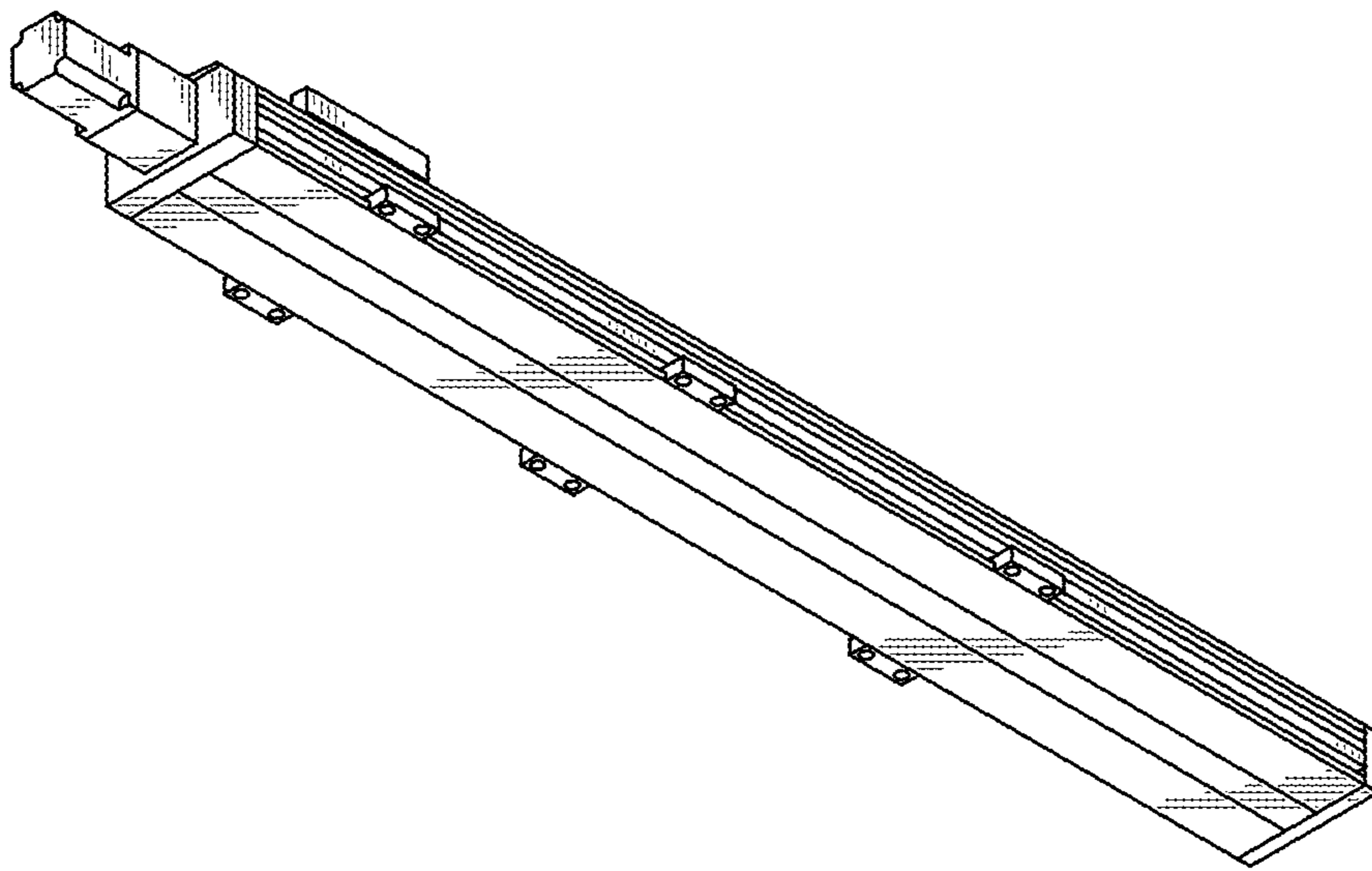

FIG. 35

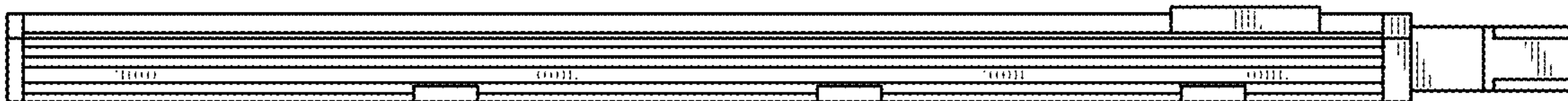

FIG. 36



FIG. 37

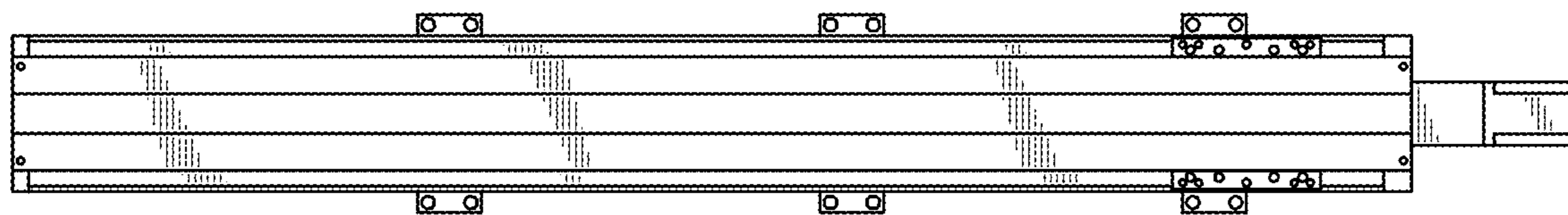

FIG. 38

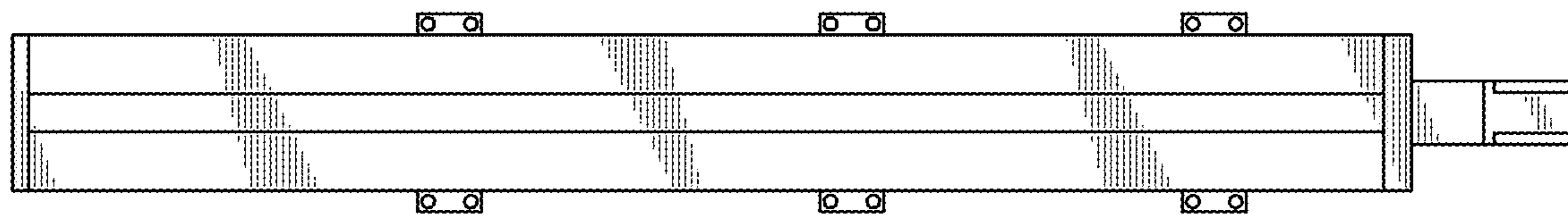

FIG. 39

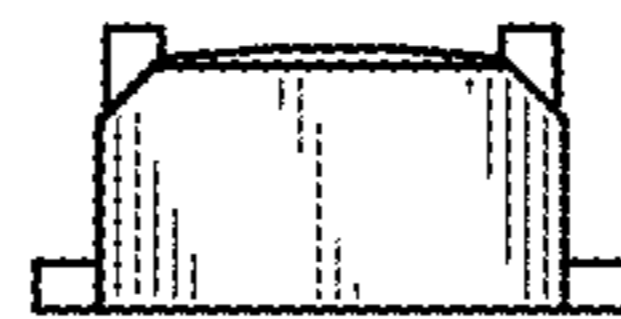

FIG. 40

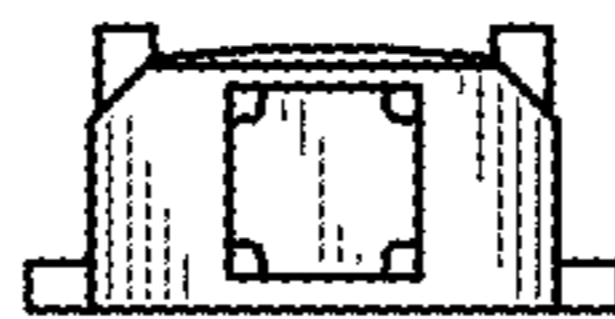

FIG. 41

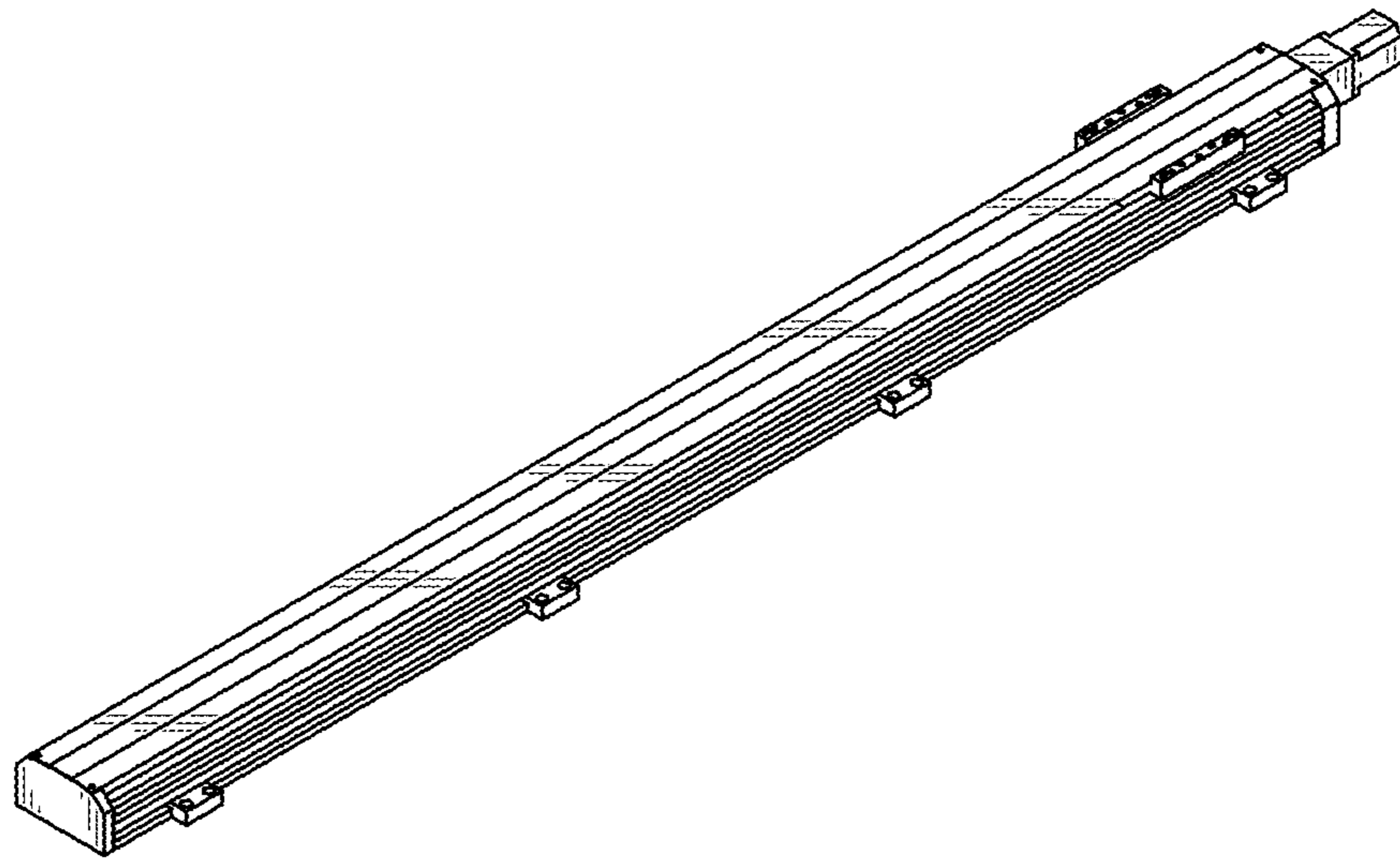

FIG. 42

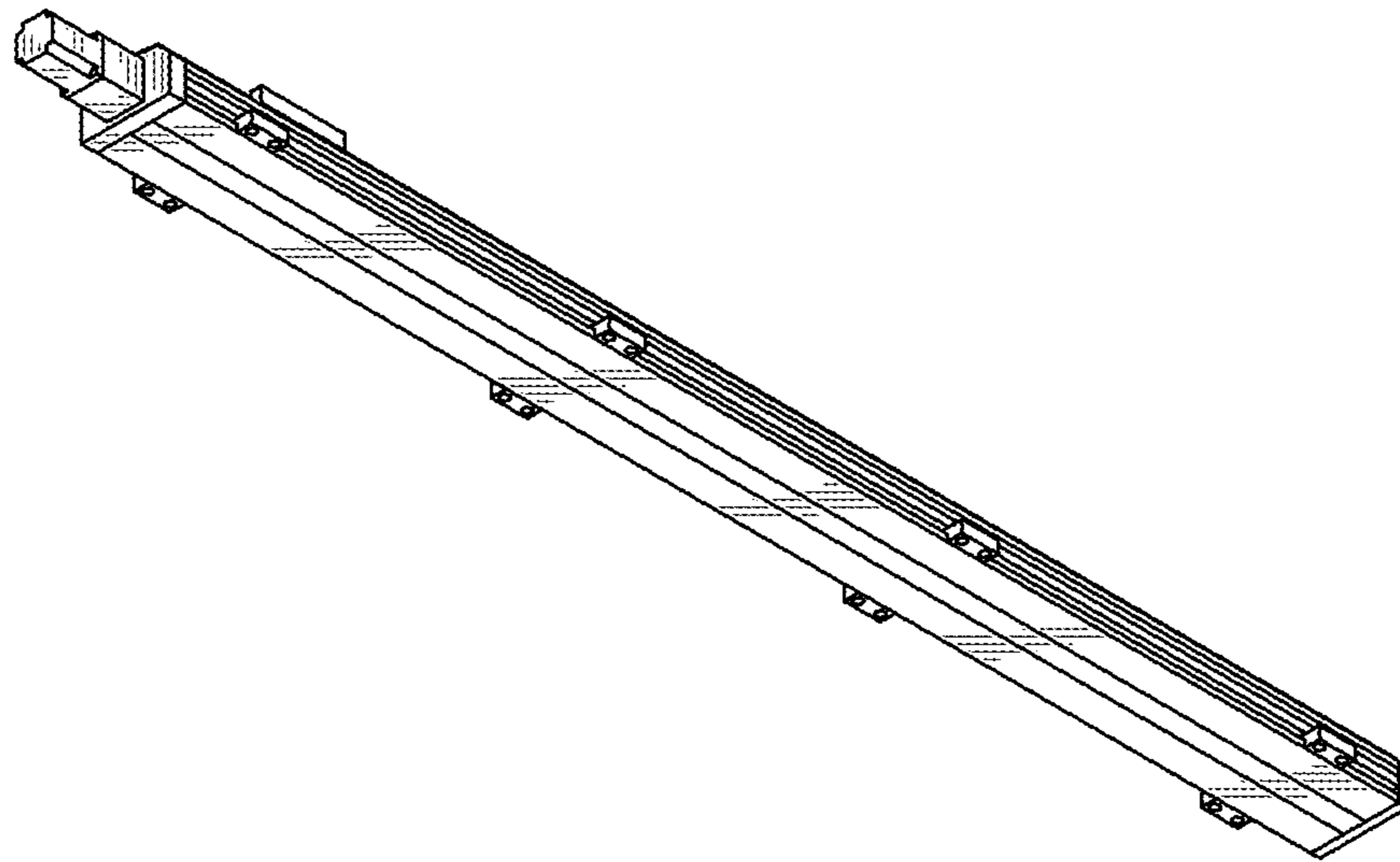

FIG. 43

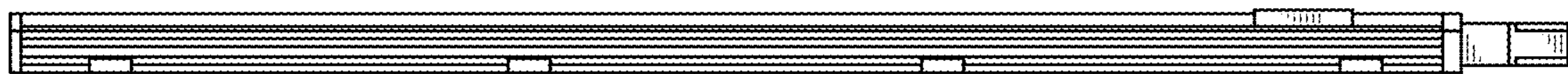

FIG. 44

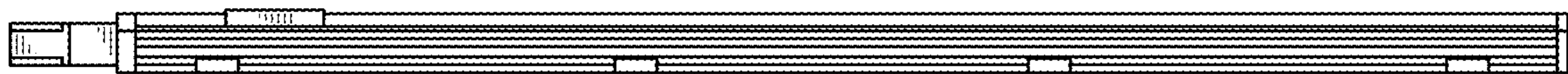

FIG. 45

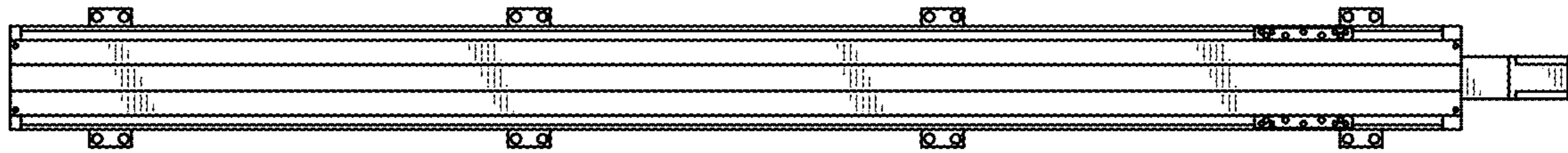

FIG. 46

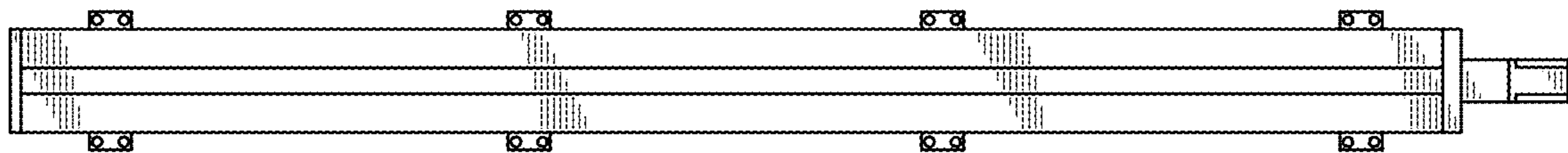

FIG. 47



FIG. 48

