



US00D962079S

(12) **United States Design Patent** (10) **Patent No.:** **US D962,079 S**  
**Maccario** (45) **Date of Patent:** **\*\* Aug. 30, 2022**

(54) **TISSUE BOX**  
(71) Applicant: **Susan C. Maccario**, Naples, FL (US)  
(72) Inventor: **Susan C. Maccario**, Naples, FL (US)  
(\*\*) Term: **15 Years**  
(21) Appl. No.: **29/773,577**  
(22) Filed: **Mar. 10, 2021**  
(51) **LOC (13) Cl.** ..... **09-01**  
(52) **U.S. Cl.**  
USPC ..... **D9/734**  
(58) **Field of Classification Search**  
USPC ..... D9/414, 430, 432, 431, 730, 734;  
D3/201, 304, 315; D6/518  
CPC ..... A47K 10/185; A47K 10/421; A47K  
2010/3266; A47K 10/18; A47K 10/426;  
A47K 10/42; B65D 83/0894; B65D 5/72;  
B65D 83/0888; B65D 83/0805  
See application file for complete search history.

(56) **References Cited**  
U.S. PATENT DOCUMENTS  
5,540,354 A \* 7/1996 Annand ..... A47K 10/423  
206/449  
6,296,143 B1 \* 10/2001 Ghabriel ..... A47K 10/426  
221/48  
D622,989 S \* 9/2010 Lagler ..... D6/515  
D623,961 S 9/2010 Maccario  
8,146,927 B2 4/2012 Maccario  
D702,565 S \* 4/2014 Gale ..... D9/734  
8,752,729 B2 6/2014 Maccario  
D709,391 S \* 7/2014 Neely ..... D10/46  
10,882,686 B2 \* 1/2021 Berry ..... B65D 83/0805  
D938,284 S \* 12/2021 Kurker ..... D9/734  
2004/0060941 A1 \* 4/2004 Middione ..... B65D 83/0888  
220/661

2004/0245266 A1 \* 12/2004 Mitchell ..... B65D 75/566  
221/33  
2004/0251590 A1 \* 12/2004 Mitchell ..... A47K 10/42  
271/33  
2005/0263575 A1 \* 12/2005 Weinmann ..... B65F 1/1607  
229/122.1  
2008/0223867 A1 \* 9/2008 Carr ..... A47K 10/46  
221/34  
2013/0228589 A1 \* 9/2013 Nickerson ..... A47K 10/46  
221/102  
2016/0262582 A1 \* 9/2016 Henige ..... B65D 83/0888  
2018/0228321 A1 \* 8/2018 Kurker ..... B65F 1/1426  
2022/0061600 A1 \* 3/2022 Gano ..... A47K 10/422

\* cited by examiner

*Primary Examiner* — Lauren R Calve  
(74) *Attorney, Agent, or Firm* — Jacob M. Ward; Ward Law Office LLC

(57) **CLAIM**

The ornamental design for a tissue box, as shown and described.

**DESCRIPTION**

FIG. 1 is a top perspective view of a tissue box according to the present disclosure;  
FIG. 2 is a top plan view of the tissue box shown in FIG. 1;  
FIG. 3 is a front elevational view thereof; and,  
FIG. 4 is a right side elevational view thereof.  
A rear elevational view is not shown because it is an identical image to the right side elevational view shown in FIG. 4. A left side elevational view is not shown because it is an identical image to the right side elevational view shown in FIG. 4. A bottom plan view is not shown because it is an identical image to the right side elevational view shown in FIG. 4.  
The broken lines shown represent portions of the tissue box that form no part of the claimed design.

**1 Claim, 3 Drawing Sheets**

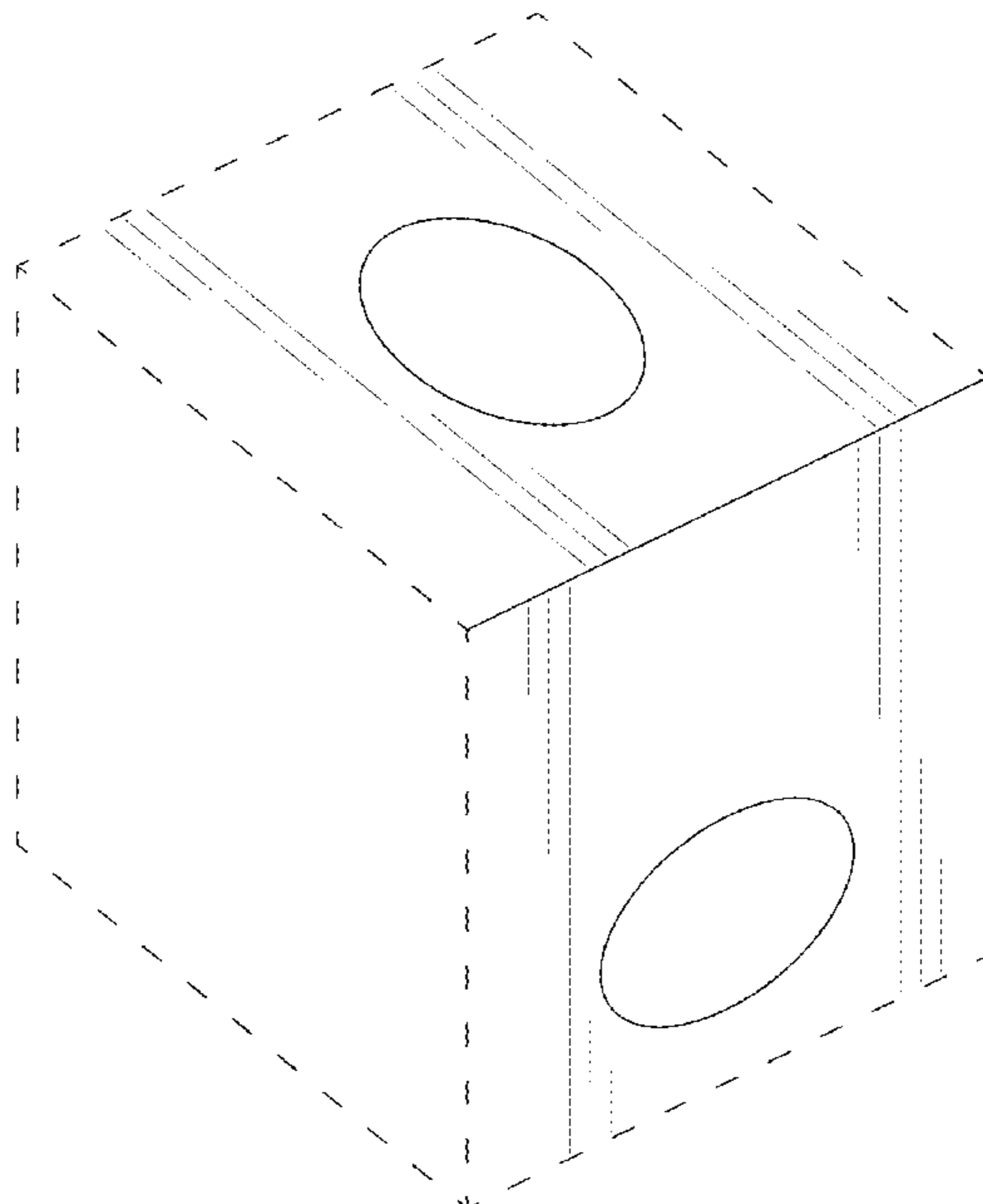

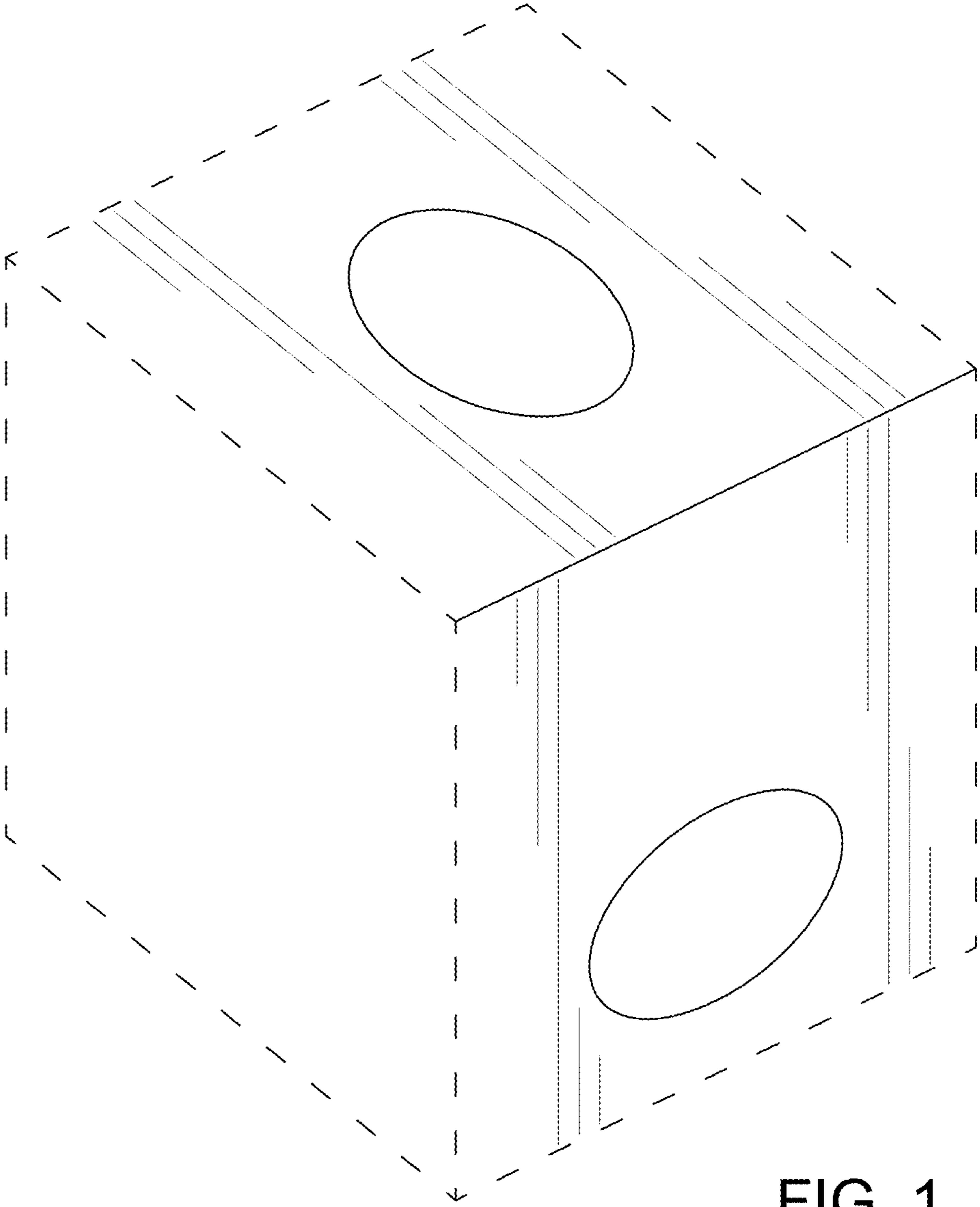

FIG. 1

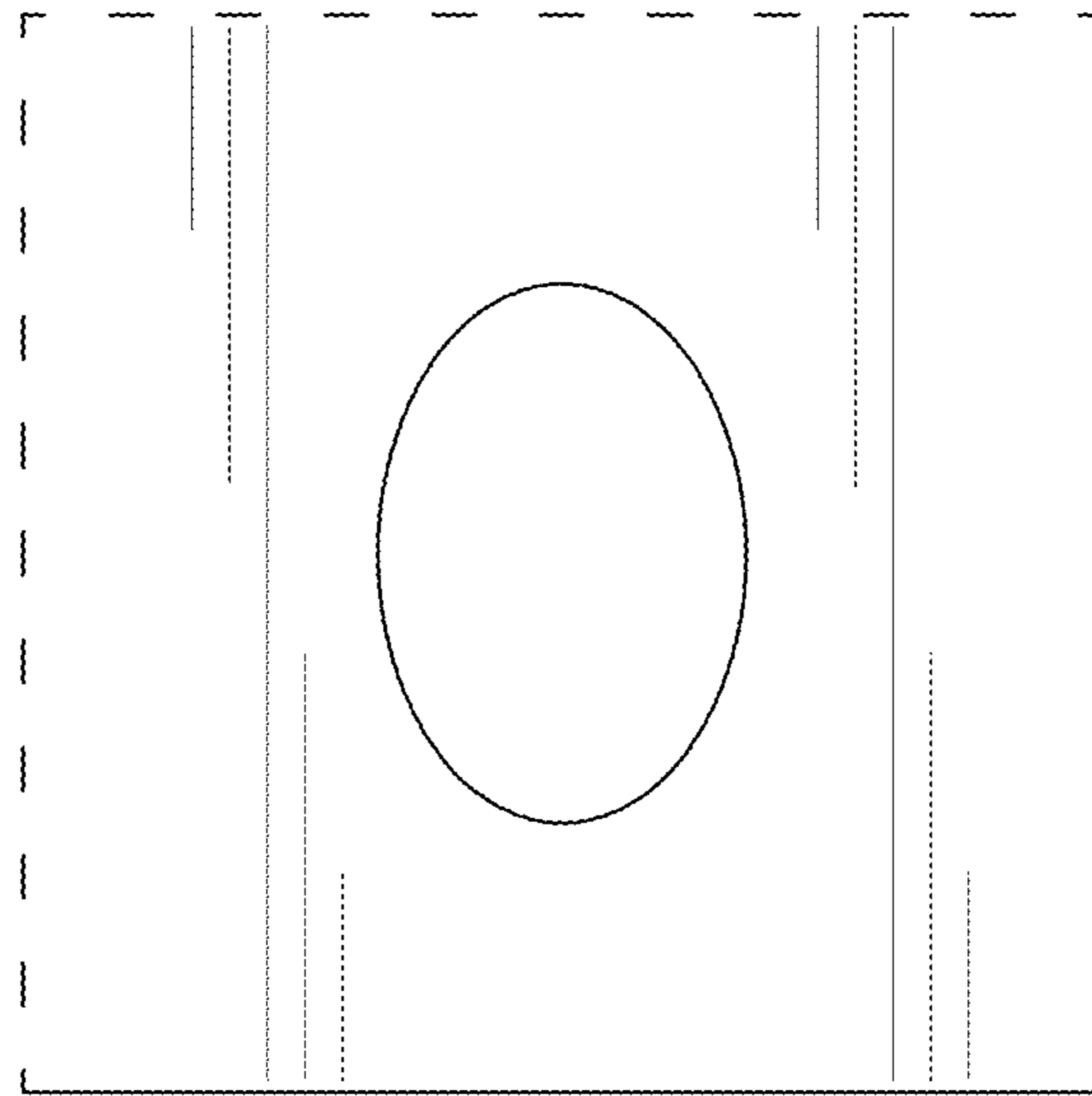

FIG. 2

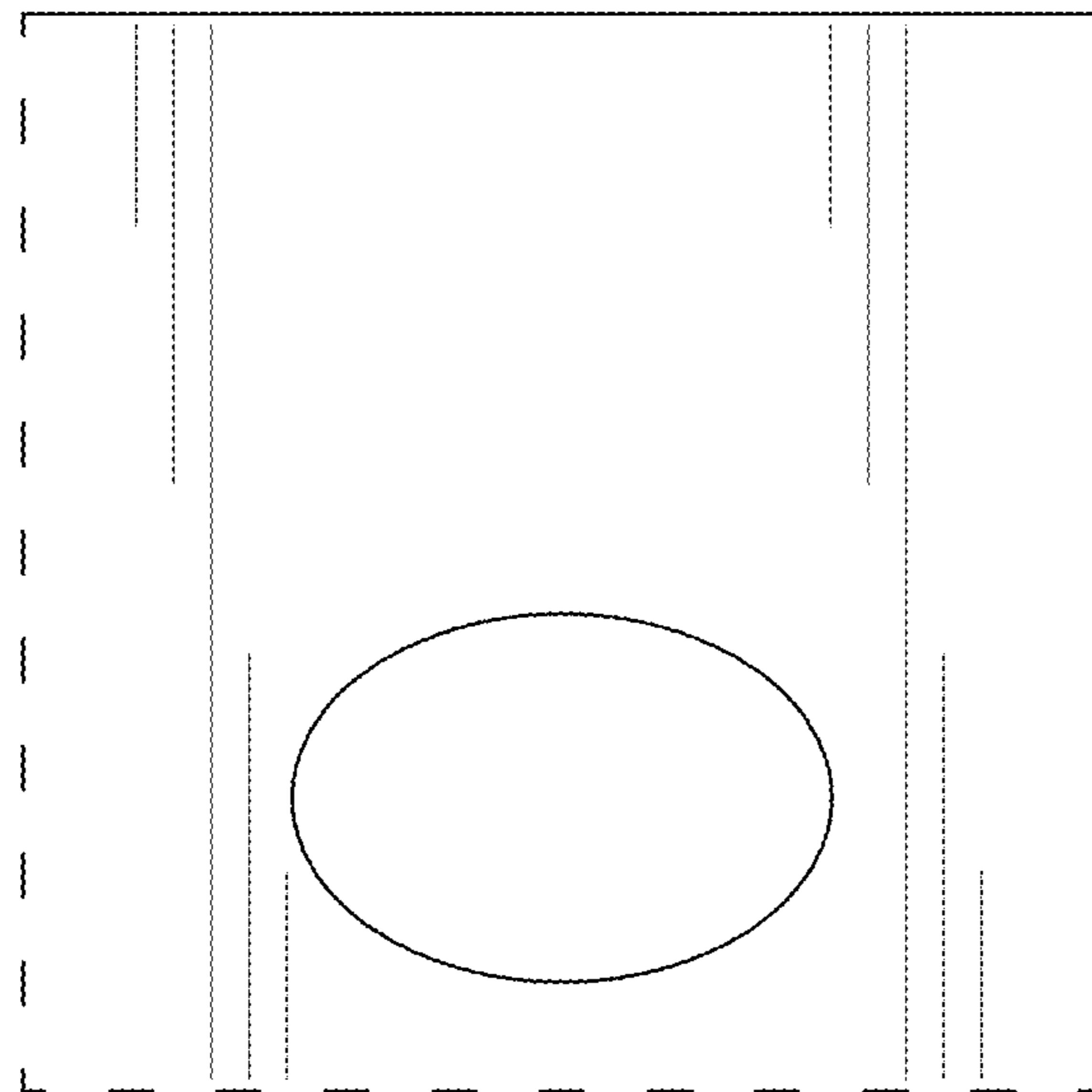

FIG. 3

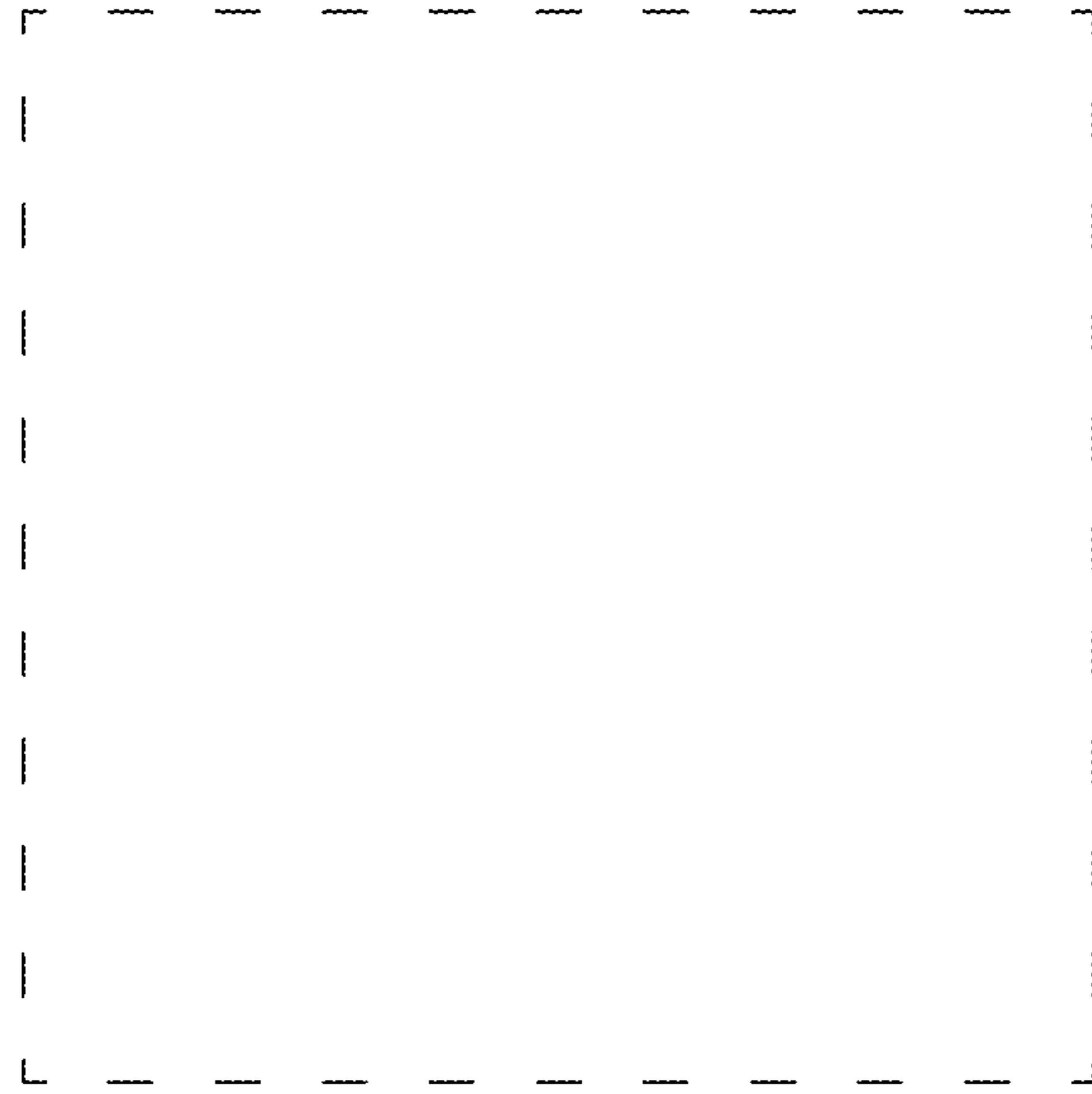

FIG. 4