



US00D961782S

(12) **United States Design Patent**
Locke et al.

(10) **Patent No.:** **US D961,782 S**
(45) **Date of Patent:** **** Aug. 23, 2022**

(54) **LOW-PROFILE FLUID CONDUCTOR FOR TISSUE THERAPY**

(71) Applicant: **KCI Licensing, Inc.**, San Antonio, TX (US)

(72) Inventors: **Christopher Brian Locke**, Bournemouth (GB); **Thomas Edwards**, Southampton (GB)

(73) Assignee: **KCI Licensing, Inc.**, San Antonio, TX (US)

(**) Term: **15 Years**

(21) Appl. No.: **29/667,667**

(22) Filed: **Oct. 23, 2018**

(51) **LOC (13) Cl.** **24-04**

(52) **U.S. Cl.**
USPC **D24/189**

(58) **Field of Classification Search**
USPC D24/201–205, 213, 187–192;
D23/276–278, 280.1–280.3; D25/2
(Continued)

(56) **References Cited**

U.S. PATENT DOCUMENTS

1,355,846 A 10/1920 Rannells
2,547,758 A 4/1951 Keeling
(Continued)

FOREIGN PATENT DOCUMENTS

AU 550575 B2 3/1986
AU 745271 B2 3/2002
(Continued)

OTHER PUBLICATIONS

Partial International Search Report for Corresponding Application No. PCT/US2018/057109, dated Feb. 1, 2019.

(Continued)

Primary Examiner — Mary Shannon Malley

(57) **CLAIM**

We claim the ornamental design for low-profile fluid conductors for tissue therapy, as shown and described.

DESCRIPTION

FIG. 1 is a bottom isometric view showing a first embodiment of the low-profile fluid conductor for tissue therapy; FIG. 2 is a right elevation view showing the first embodiment of the low-profile fluid conductor for tissue therapy; FIG. 3 is a left elevation view showing the first embodiment of the low-profile fluid conductor for tissue therapy; FIG. 4 is a front elevation view showing the first embodiment of the low-profile fluid conductor for tissue therapy; FIG. 5 is a rear elevation view showing the first embodiment of the low-profile fluid conductor for tissue therapy; FIG. 6 is a top plan view showing the first embodiment of the low-profile fluid conductor for tissue therapy; FIG. 7 is a bottom plan view showing the first embodiment of the low-profile fluid conductor for tissue therapy; FIG. 8 is a bottom isometric view showing a second embodiment of the low-profile fluid conductor for tissue therapy; FIG. 9 is a right elevation view showing the second embodiment of the low-profile fluid conductor for tissue therapy; FIG. 10 is a left elevation view showing the second embodiment of the low-profile fluid conductor for tissue therapy; FIG. 11 is a front elevation view showing the second embodiment of the low-profile fluid conductor for tissue therapy; FIG. 12 is a rear elevation view showing the second embodiment of the low-profile fluid conductor for tissue therapy; FIG. 13 is a top plan view showing the second embodiment of the low-profile fluid conductor for tissue therapy; and, FIG. 14 is a bottom plan view showing the second embodiment of the low-profile fluid conductor for tissue therapy. The dash dash broken lines depict portions of the low profile fluid conductor for tissue therapy that form no part of the claimed design. The dot dash broken lines depict the boundaries of the claimed design, and form no part thereof.

1 Claim, 6 Drawing Sheets

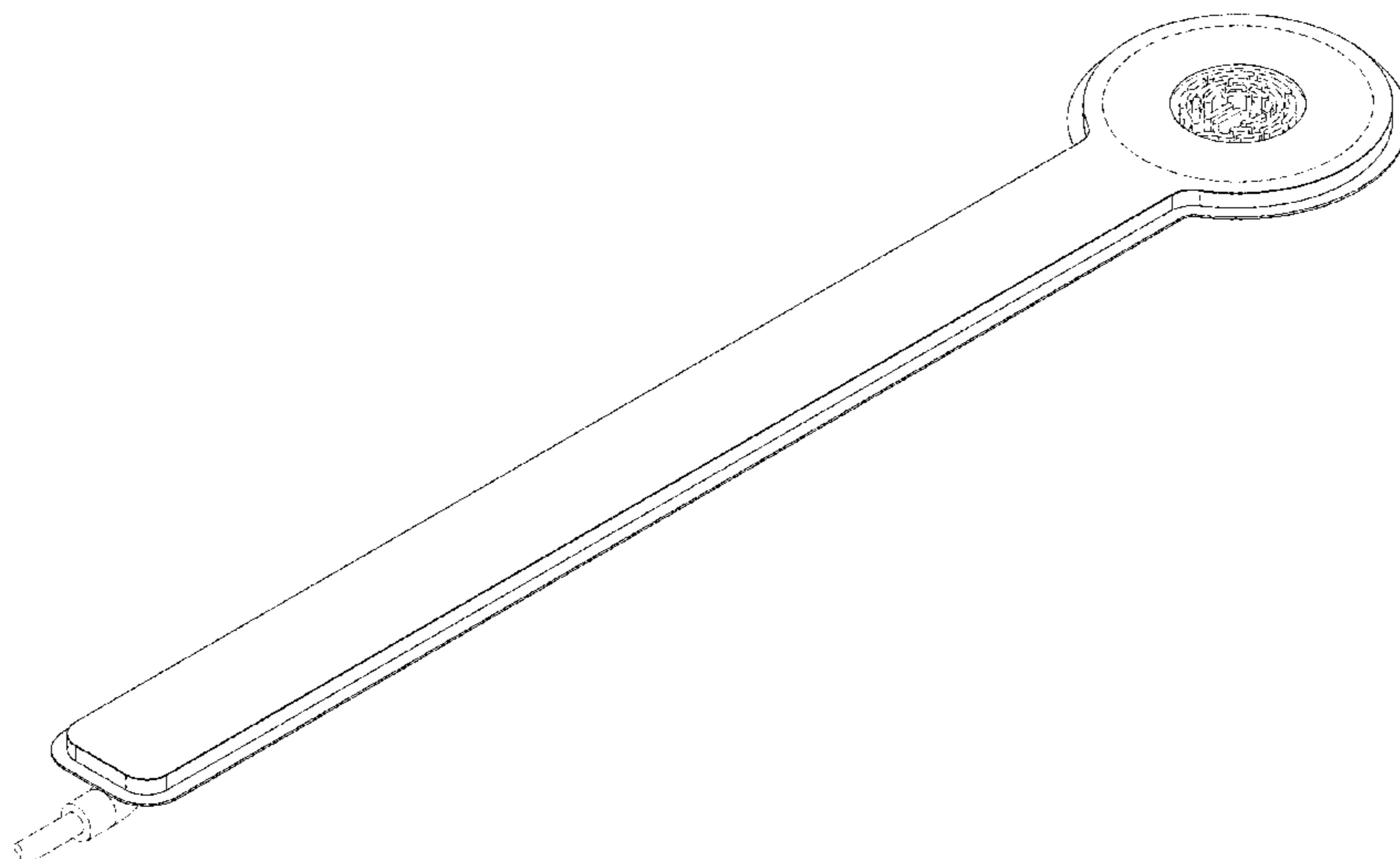

(58) **Field of Classification Search**
 CPC A61H 33/6005; A61H 33/6021; A61H
 2035/004; A61H 35/006; A61H 33/6089;
 A61H 33/6094; A47K 3/022; A47K 3/062
 See application file for complete search history.

(56) **References Cited**

U.S. PATENT DOCUMENTS

| | | | | | |
|-------------|---------|--------------------|-------------------|---------|--|
| 2,632,443 A | 3/1953 | Leshner | 5,149,331 A | 9/1992 | Ferdman et al. |
| 2,682,873 A | 7/1954 | Evans et al. | 5,167,613 A | 12/1992 | Karami et al. |
| 2,910,763 A | 11/1959 | Lauterbach | 5,176,663 A | 1/1993 | Svedman et al. |
| 2,969,057 A | 1/1961 | Simmons | 5,215,522 A | 6/1993 | Page et al. |
| 3,066,672 A | 12/1962 | Crosby, Jr. et al. | 5,232,453 A | 8/1993 | Plass et al. |
| 3,367,332 A | 2/1968 | Groves | 5,261,893 A | 11/1993 | Zamierowski |
| 3,520,300 A | 7/1970 | Flower, Jr. | 5,278,100 A | 1/1994 | Doan et al. |
| 3,568,675 A | 3/1971 | Harvey | 5,279,550 A | 1/1994 | Habib et al. |
| 3,648,692 A | 3/1972 | Wheeler | 5,298,015 A | 3/1994 | Komatsuzaki et al. |
| 3,682,180 A | 8/1972 | McFarlane | 5,342,376 A | 8/1994 | Ruff |
| 3,826,254 A | 7/1974 | Mellor | 5,344,415 A | 9/1994 | DeBusk et al. |
| 4,080,970 A | 3/1978 | Miller | 5,358,494 A | 10/1994 | Svedman |
| 4,096,853 A | 6/1978 | Weigand | 5,437,622 A | 8/1995 | Carion |
| 4,139,004 A | 2/1979 | Gonzalez, Jr. | 5,437,651 A | 8/1995 | Todd et al. |
| 4,165,748 A | 8/1979 | Johnson | 5,458,141 A * | 10/1995 | Neil A61B 5/25 600/386 |
| 4,184,510 A | 1/1980 | Murry et al. | 5,527,293 A | 6/1996 | Zamierowski |
| 4,233,969 A | 11/1980 | Lock et al. | 5,549,584 A | 8/1996 | Gross |
| 4,245,630 A | 1/1981 | Lloyd et al. | 5,556,375 A | 9/1996 | Ewall |
| 4,256,109 A | 3/1981 | Nichols | 5,607,388 A | 3/1997 | Ewall |
| 4,261,363 A | 4/1981 | Russo | 5,636,643 A | 6/1997 | Argenta et al. |
| 4,275,721 A | 6/1981 | Olson | 5,645,081 A | 7/1997 | Argenta et al. |
| 4,284,079 A | 8/1981 | Adair | 6,071,267 A | 6/2000 | Zamierowski |
| 4,297,995 A | 11/1981 | Golub | 6,135,116 A | 10/2000 | Vogel et al. |
| 4,333,468 A | 6/1982 | Geist | 6,241,747 B1 | 6/2001 | Ruff |
| 4,373,519 A | 2/1983 | Errede et al. | 6,287,316 B1 | 9/2001 | Agarwal et al. |
| 4,382,441 A | 5/1983 | Svedman | 6,345,623 B1 | 2/2002 | Heaton et al. |
| 4,392,853 A | 7/1983 | Muto | 6,488,643 B1 | 12/2002 | Tumey et al. |
| 4,392,858 A | 7/1983 | George et al. | 6,493,568 B1 | 12/2002 | Bell et al. |
| 4,419,097 A | 12/1983 | Rowland | 6,553,998 B2 | 4/2003 | Heaton et al. |
| 4,465,485 A | 8/1984 | Kashmer et al. | 6,814,079 B2 | 11/2004 | Heaton et al. |
| 4,475,909 A | 10/1984 | Eisenberg | 7,846,141 B2 | 12/2010 | Weston |
| 4,480,638 A | 11/1984 | Schmid | 8,062,273 B2 | 11/2011 | Weston |
| 4,525,166 A | 6/1985 | Leclerc | D663,431 S * | 7/2012 | Parker, III D24/187 |
| 4,525,374 A | 6/1985 | Vaillancourt | 8,216,198 B2 | 7/2012 | Heagle et al. |
| 4,540,412 A | 9/1985 | Van Overloop | 8,251,979 B2 | 8/2012 | Malhi |
| 4,543,100 A | 9/1985 | Brodsky | 8,257,327 B2 | 9/2012 | Blott et al. |
| 4,548,202 A | 10/1985 | Duncan | 8,398,614 B2 | 3/2013 | Blott et al. |
| 4,551,139 A | 11/1985 | Plaas et al. | 8,449,509 B2 | 5/2013 | Weston |
| 4,569,348 A | 2/1986 | Hasslinger | D686,329 S * | 7/2013 | Traboulsi A61N 5/1049 D24/189 |
| 4,605,399 A | 8/1986 | Weston et al. | 8,529,548 B2 | 9/2013 | Blott et al. |
| 4,608,041 A | 8/1986 | Nielsen | 8,535,296 B2 | 9/2013 | Blott et al. |
| 4,640,688 A | 2/1987 | Hauser | 8,551,060 B2 | 10/2013 | Schuessler et al. |
| 4,655,754 A | 4/1987 | Richmond et al. | 8,568,386 B2 | 10/2013 | Malhi |
| 4,664,662 A | 5/1987 | Webster | 8,679,081 B2 | 3/2014 | Heagle et al. |
| 4,710,165 A | 12/1987 | McNeil et al. | D707,830 S * | 6/2014 | Klutts D24/190 |
| 4,733,659 A | 3/1988 | Edenbaum et al. | 8,834,451 B2 | 9/2014 | Blott et al. |
| 4,743,232 A | 5/1988 | Kruger | 8,926,592 B2 | 1/2015 | Blott et al. |
| 4,758,220 A | 7/1988 | Sundblom et al. | 9,017,302 B2 | 4/2015 | Vitaris et al. |
| 4,787,888 A | 11/1988 | Fox | D744,659 S * | 12/2015 | Bishay D24/187 |
| 4,826,494 A | 5/1989 | Richmond et al. | 9,198,801 B2 | 12/2015 | Weston |
| 4,838,883 A | 6/1989 | Matsuura | 9,211,365 B2 | 12/2015 | Weston |
| 4,840,187 A | 6/1989 | Brazier | 9,289,542 B2 | 3/2016 | Blott et al. |
| 4,863,449 A | 9/1989 | Therriault et al. | 9,693,907 B2 * | 7/2017 | Locke A61F 13/0209 |
| 4,872,450 A | 10/1989 | Bustad | D806,256 S * | 12/2017 | Allen A61M 1/0056 D24/189 |
| 4,878,901 A | 11/1989 | Sachse | 10,537,478 B2 | 1/2020 | Holm et al. |
| 4,897,081 A | 1/1990 | Poirier et al. | D885,587 S * | 5/2020 | Park D24/189 |
| 4,906,233 A | 3/1990 | Moriuchi et al. | D887,563 S * | 6/2020 | Caneppele D24/189 |
| 4,906,240 A | 3/1990 | Reed et al. | D890,936 S * | 7/2020 | Hicken D24/189 |
| 4,919,654 A | 4/1990 | Kalt | 10,702,419 B2 * | 7/2020 | Locke A61F 13/022 |
| 4,941,882 A | 7/1990 | Ward et al. | D893,034 S * | 8/2020 | Kase D24/189 |
| 4,953,565 A | 9/1990 | Tachibana et al. | D898,925 S * | 10/2020 | Kelbie D24/189 |
| 4,969,880 A | 11/1990 | Zamierowski | 2002/0077661 A1 | 6/2002 | Saadat |
| 4,985,019 A | 1/1991 | Michelson | 2002/0115951 A1 | 8/2002 | Norstrem et al. |
| 5,037,397 A | 8/1991 | Kalt et al. | 2002/0120185 A1 | 8/2002 | Johnson |
| 5,086,170 A | 2/1992 | Luheshi et al. | 2002/0143286 A1 | 10/2002 | Tumey |
| 5,092,858 A | 3/1992 | Benson et al. | 2008/0195017 A1 * | 8/2008 | Robinson A61F 13/0203 602/44 |
| 5,100,396 A | 3/1992 | Zamierowski | 2010/0160877 A1 | 6/2010 | Kagan et al. |
| 5,134,994 A | 8/1992 | Say | 2012/0308780 A1 | 12/2012 | Rottger et al. |
| | | | 2013/0296816 A1 | 11/2013 | Greener |
| | | | 2014/0163491 A1 | 6/2014 | Schuessler et al. |
| | | | 2015/0080788 A1 | 3/2015 | Blott et al. |
| | | | 2015/0141941 A1 | 5/2015 | Allen et al. |
| | | | 2015/0245950 A1 * | 9/2015 | Locke A61F 13/0216 604/319 |
| | | | 2015/0320603 A1 | 11/2015 | Locke et al. |

(56)

References Cited

U.S. PATENT DOCUMENTS

| | | | |
|--------------|-----|---------|----------------------------|
| 2016/0120706 | A1 | 5/2016 | Collinson et al. |
| 2017/0143552 | A1 | 5/2017 | Hartwell et al. |
| 2017/0189236 | A1* | 7/2017 | Locke A61F 13/025 |
| 2017/0312402 | A1 | 11/2017 | McDonald |
| 2018/0228654 | A1 | 8/2018 | Sarangapani et al. |
| 2019/0117861 | A1* | 4/2019 | Locke A61F 13/00068 |
| 2020/0146897 | A1* | 5/2020 | Locke A61F 13/0216 |
| 2020/0353137 | A1* | 11/2020 | Long A61M 1/73 |
| 2020/0375805 | A1 | 12/2020 | Robinson et al. |
| 2021/0161725 | A1* | 6/2021 | Edwards A61F 13/0216 |

FOREIGN PATENT DOCUMENTS

| | | | |
|----|-------------|----|---------|
| AU | 755496 | B2 | 12/2002 |
| CA | 2005436 | A1 | 6/1990 |
| DE | 26 40 413 | A1 | 3/1978 |
| DE | 43 06 478 | A1 | 9/1994 |
| DE | 29 504 378 | U1 | 9/1995 |
| EP | 0100148 | A1 | 2/1984 |
| EP | 0117632 | A2 | 9/1984 |
| EP | 0161865 | A2 | 11/1985 |
| EP | 0358302 | A2 | 3/1990 |
| EP | 1018967 | A1 | 7/2000 |
| GB | 692578 | A | 6/1953 |
| GB | 2195255 | A | 4/1988 |
| GB | 2 197 789 | A | 6/1988 |
| GB | 2 220 357 | A | 1/1990 |
| GB | 2 235 877 | A | 3/1991 |
| GB | 2 329 127 | A | 3/1999 |
| GB | 2 333 965 | A | 8/1999 |
| JP | 4129536 | B2 | 8/2008 |
| SG | 71559 | | 4/2002 |
| WO | 80/02182 | A1 | 10/1980 |
| WO | 87/04626 | A1 | 8/1987 |
| WO | 90/010424 | A1 | 9/1990 |
| WO | 93/009727 | A1 | 5/1993 |
| WO | 94/20041 | A1 | 9/1994 |
| WO | 96/05873 | A1 | 2/1996 |
| WO | 97/18007 | A1 | 5/1997 |
| WO | 99/13793 | A1 | 3/1999 |
| WO | 2013/175306 | A2 | 11/2013 |
| WO | 2016193873 | A1 | 12/2016 |

OTHER PUBLICATIONS

Japanese Notice of Rejection for Corresponding Application No. 2019-006180, dated Nov. 26, 2019.

Louis C. Argenta, MD and Michael J. Morykwas, PHD; Vacuum-Assisted Closure: A New Method for Wound Control and Treatment: Clinical Experience; *Annals of Plastic Surgery*; vol. 38, No. 6, Jun. 1997; pp. 563-576.

Susan Mendez-Eatmen, RN; "When wounds Won't Heal" *RN* Jan. 1998, vol. 61 (1); Medical Economics Company, Inc., Montvale, NJ, USA; pp. 20-24.

James H. Blackburn II, MD et al.: Negative-Pressure Dressings as a Bolster for Skin Grafts; *Annals of Plastic Surgery*, vol. 40, No. 5, May 1998, pp. 453-457; Lippincott Williams & Wilkins, Inc., Philadelphia, PA, USA.

John Masters; "Reliable, Inexpensive and Simple Suction Dressings"; Letter to the Editor, *British Journal of Plastic Surgery*, 1998, vol. 51 (3), p. 267; Elsevier Science/The British Association of Plastic Surgeons, UK.

S.E. Greer, et al. "The Use of Subatmospheric Pressure Dressing Therapy to Close Lymphocutaneous Fistulas of the Groin" *British Journal of Plastic Surgery* (2000), 53, pp. 484-487.

George V. Letsou, MD., et al; "Stimulation of Adenylate Cyclase Activity in Cultured Endothelial Cells Subjected to Cyclic Stretch"; *Journal of Cardiovascular Surgery*, 31, 1990, pp. 634-639.

Orringer, Jay, et al.; "Management of Wounds in Patients with Complex Enterocutaneous Fistulas"; *Surgery, Gynecology & Obstetrics*, Jul. 1987, vol. 165, pp. 79-80.

International Search Report for PCT International Application PCT/GB95/01983; dated Nov. 23, 1995.

PCT International Search Report for PCT International Application PCT/GB98/02713; dated Jan. 8, 1999.

PCT Written Opinion; PCT International Application PCT/GB98/02713; dated Jun. 8, 1999.

PCT International Examination and Search Report, PCT International Application PCT/GB96/02802; dated Jan. 15, 1998 & Apr. 29, 1997.

PCT Written Opinion, PCT International Application PCT/GB96/02802; dated Sept. 3, 1997.

Dattilo, Philip P., Jr., et al; "Medical Textiles: Application of an Absorbable Barbed Bi-directional Surgical Suture"; *Journal of Textile and Apparel, Technology and Management*, vol. 2, Issue 2, Spring 2002, pp. 1-5.

Kostyuchenok, B.M., et al; "Vacuum Treatment in the Surgical Management of Purulent Wounds"; *Vestnik Khirurgi*, Sep. 1986, pp. 18-21 and 6 page English translation thereof.

Davydov, Yu. A., et al; "Vacuum Therapy in the Treatment of Purulent Lactation Mastitis"; *Vestnik Khirurgi*, May 14, 1986, pp. 66-70, and 9 page English translation thereof.

Yusupov, Yu.N., et al; "Active Wound Drainage"; *Vestnik Khirurgi*, vol. 138, Issue 4, 1987, and 7 page English translation thereof.

Davydov, Yu.A., et al; "Bacteriological and Cytological Assessment of Vacuum Therapy for Purulent Wounds"; *Vestnik Khirurgi*, Oct. 1988, pp. 48-52, and 8 page English translation thereof.

Davydov, Yu.A., et al; "Concepts for the Clinical-Biological Management of the Wound Process in the Treatment of Purulent Wounds by Means of Vacuum Therapy"; *Vestnik Khirurgi*, Jul. 7, 1980, pp. 132-136, and 8 page English translation thereof.

Chariker, Mark E., M.D., et al; "Effective Management of incisional and cutaneous fistulae with closed suction wound drainage"; *Contemporary Surgery*, vol. 34, Jun. 1989, pp. 59-63.

Egnell Minor, *Instruction Book*, First Edition, 300 7502, Feb. 1975, pp. 24.

Svedman, P.: "Irrigation Treatment of Leg Ulcers", *The Lancet*, Sep. 3, 1983, pp. 532-534.

Chinn, Steven D. et al.: "Closed Wound Suction Drainage", *The Journal of Foot Surgery*, vol. 24, No. 1, 1985, pp. 76-81.

Arnljots, Björn et al.: "Irrigation Treatment in Split-Thickness Skin Grafting of Intractable Leg Ulcers", *Scand J. Plast Reconstr. Surg.*, No. 19, 1985, pp. 211-213.

Svedman, P.: "A Dressing Allowing Continuous Treatment of a Biosurface", *IRCS Medical Science: Biomedical Technology, Clinical Medicine, Surgery and Transplantation*, vol. 7, 1979, p. 221.

Svedman, P. et al: "A Dressing System Providing Fluid Supply and Suction Drainage Used for Continuous or Intermittent Irrigation", *Annals of Plastic Surgery*, vol. 17, No. 2, Aug. 1986, pp. 125-133.

N.A. Bagautdinov, "Variant of External Vacuum Aspiration in the Treatment of Purulent Diseases of Soft Tissues," *Current Problems in Modern Clinical Surgery: Interdepartmental Collection*, edited by V. Ye Volkov et al. (Chuvashia State University, Cheboksary, U.S.S.R. 1986); pp. 94-96 (copy and certified translation).

K.F. Jeter, T.E. Tintle, and M. Chariker, "Managing Draining Wounds and Fistulae: New and Established Methods," *Chronic Wound Care*, edited by D. Krasner (Health Management Publications, Inc., King of Prussia, PA 1990), pp. 240-246.

G. Živadnovi?, V. ?uki?, Ž. Maksimovi?, ?. Radak, and P. Peška, "Vacuum Therapy in the Treatment of Peripheral Blood Vessels," *Timok Medical Journal* 11 (1986), pp. 161-164 (copy and certified translation).

F.E. Johnson, "An Improved Technique for Skin Graft Placement Using a Suction Drain," *Surgery, Gynecology, and Obstetrics* 159 (1984), pp. 584-585.

M. Schein, R. Saadia, J.R. Jamieson, and G.A.G. Decker, "The 'Sandwich Technique' in the Management of the Open Abdomen," *British Journal of Surgery* 73 (1986), pp. 369-370.

D.E. Tribble, "An Improved Sump Drain-Irrigation Device of Simple Construction," *Archives of Surgery* 105 (1972) pp. 511-513.

M.J. Morykwas, L.C. Argenta, E.I. Shelton-Brown, and W. McGuirt, "Vacuum-Assisted Closure: A New Method for Wound Control and Treatment: Animal Studies and Basic Foundation," *Annals of Plastic Surgery* 38 (1997), pp. 553-562 (Morykwas I).

(56)

References Cited

OTHER PUBLICATIONS

C.E. Tennants, "The Use of Hypermia in the Postoperative Treatment of Lesions of the Extremities and Thorax," *Journal of the American Medical Association* 64 (1915), pp. 1548-1549.

Selections from W. Meyer and V. Schmieden, *Bier's Hyperemic Treatment in Surgery, Medicine, and the Specialties: A Manual of Its Practical Application*, (W.B. Saunders Co., Philadelphia, PA 1909), pp. 17-25, 44-64, 90-96, 167-170, and 210-211.

V.A. Solovev et al., *Guidelines, The Method of Treatment of Immature External Fistulas in the Upper Gastrointestinal Tract*, editor-in-chief Prov. V.I. Parahonyak (S.M. Kirov Gorky State Medical Institute, Gorky, U.S.S.R. 1987) ("Solovev Guidelines").

V.A. Kuznetsov & N.a. Bagautdinov, "Vacuum and Vacuum-Sorption Treatment of Open Septic Wounds," in *II All-Union Conference on Wounds and Wound Infections: Presentation Abstracts*, edited by B.M. Kostyuchenok et al. (Moscow, U.S.S.R. Oct. 28-29, 1986) pp. 91-92 ("Bagautdinov II").

V.A. Solovev, *Dissertation Abstract, Treatment and Prevention of Suture Failures after Gastric Resection* (S.M. Kirov Gorky State Medical Institute, Gorky, U.S.S.R. 1988) ("Solovev Abstract").

V.A.C. ® *Therapy Clinical Guidelines: A Reference Source for Clinicians*; Jul. 2007.

Egnell Minor: *Addition to the Users Manual Concerning Overflow Protection—Concerns all Egnell Pumps*, Feb. 3, 1983, pp. 2.

A.A. Safronov, *Dissertation Abstract, Vacuum Therapy of Trophic Ulcers of the Lower Leg with Simultaneous Autoplasty of the Skin* (Central Scientific Research Institute of Traumatology and Orthopedics, Moscow, U.S.S.R. 1967) (copy and certified translation).

Definition of "Hollow", Merriam-Webster, <https://www.merriam-webster.com/dictionary/hollow> (year: 2021).

Definition of "Stack", Cambridge English Dictionary, <https://dictionary.cambridge.org/us/dictionary/english/stack> (year: 2021).

U.S. Final Rejection Corresponding to U.S. Appl. No. 16/525,376, dated Sep. 14, 2021.

PTFE vs. Teflon: What's the Difference? by Teflon Coat, Performance Engineered Components, <https://www.industrialcoat.com/ptfe-vs-teflon-whats-difference/>. Aug. 8, 2018 (Year: 2018).

Definition of "Integral", Merriam-Webster Dictionary, <https://www.merriam-webster.com/dictionary/integral>, Accessed Dec. 15, 2021 (Year: 2021).

U.S. Non-Final Rejection Corresponding to U.S. Appl. No. 16/525,376, dated Jan. 4, 2022.

U.S. Non-Final Rejection for Corresponding U.S. Appl. No. 16/525,376, dated May 20, 2021.

U.S. Non-Final Rejection for Corresponding U.S. Appl. No. 16/168,426, dated Jun. 4, 2021.

"Teflon Properties", W.S. Hampshire, Inc., http://catalog.wshampshire.com/asset/psg_teflon_ptfe.pdf. Accessed 2021 (Year: 2021).

U.S. Non-Final Rejection Corresponding to U.S. Appl. No. 16/168,426, dated Oct. 15, 2021.

* cited by examiner

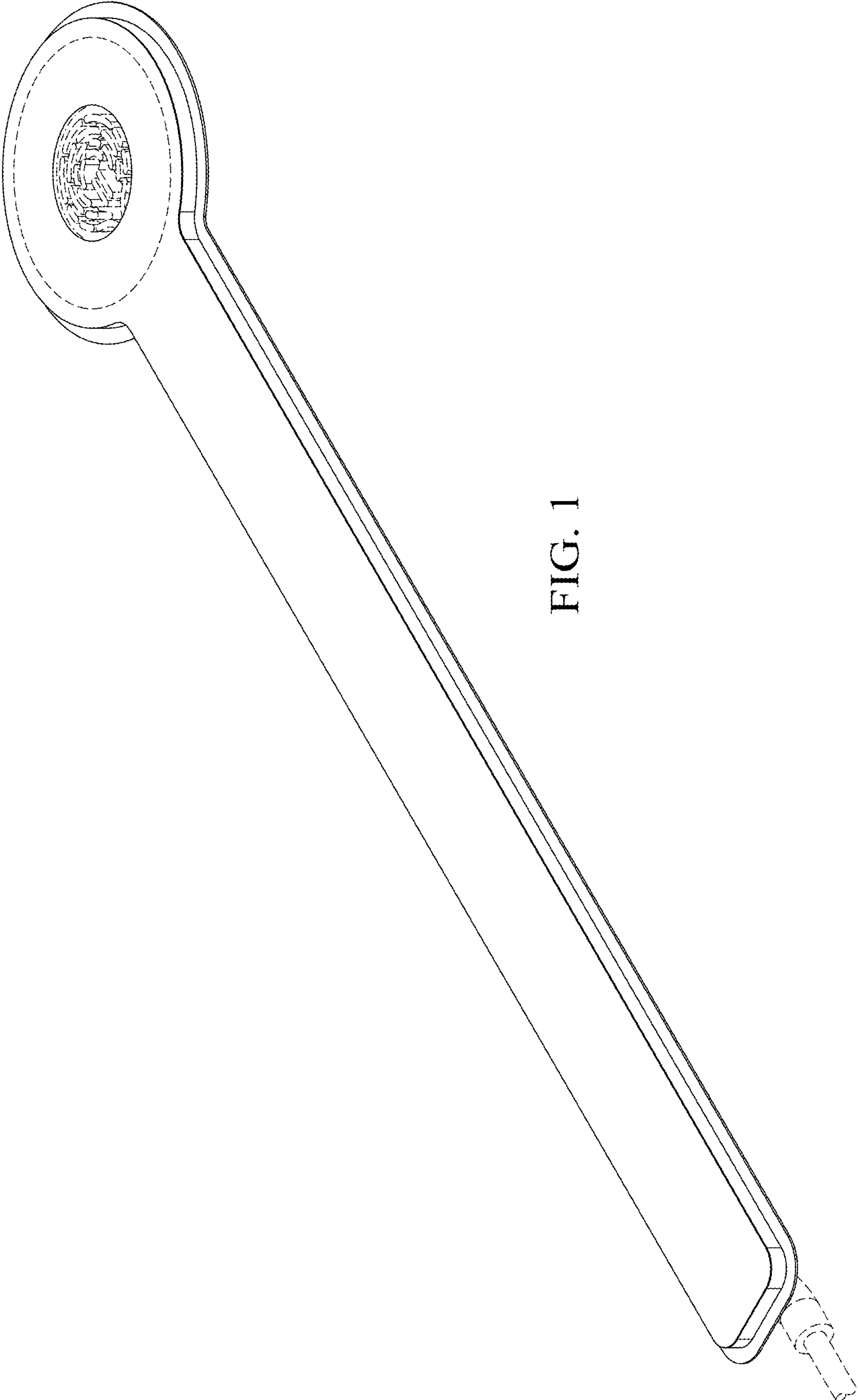

FIG. 1

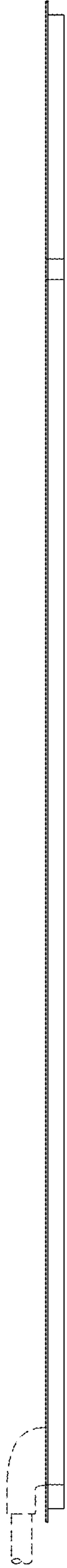

FIG. 2

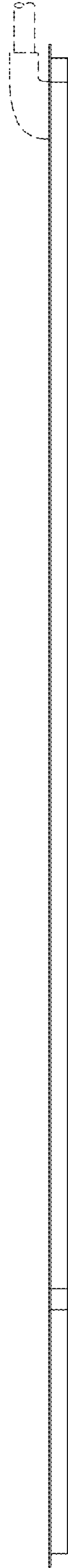

FIG. 3

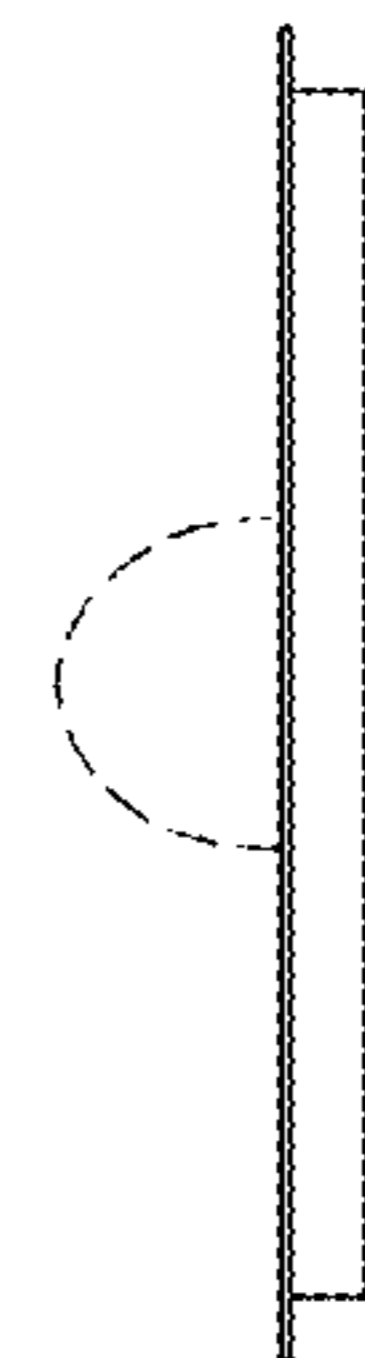

FIG. 4

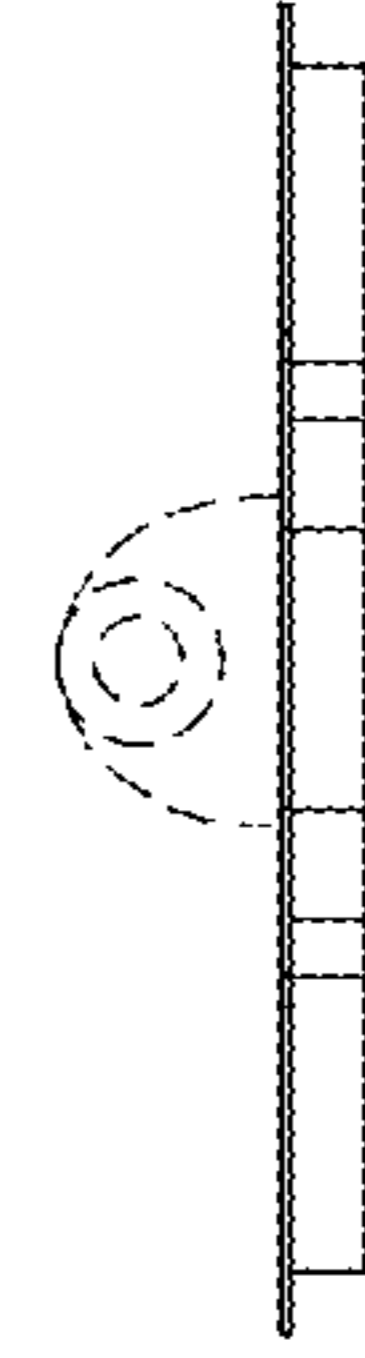

FIG. 5

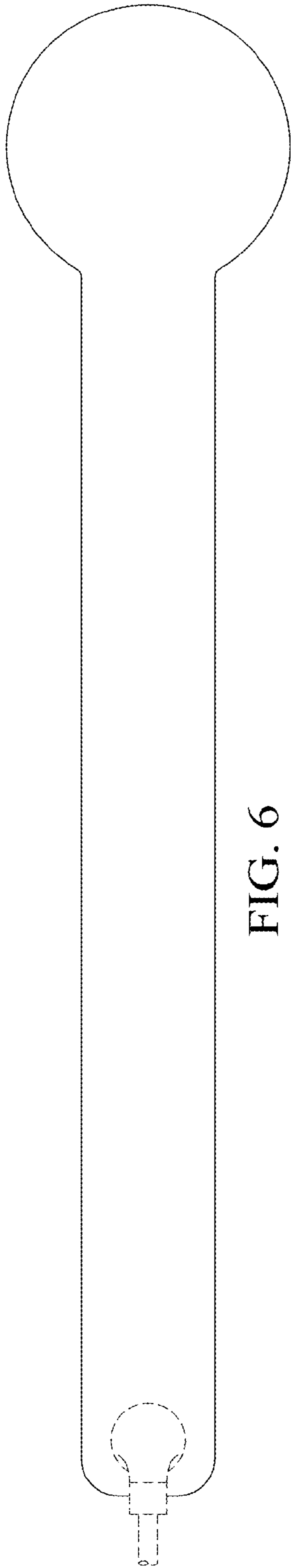

FIG. 6

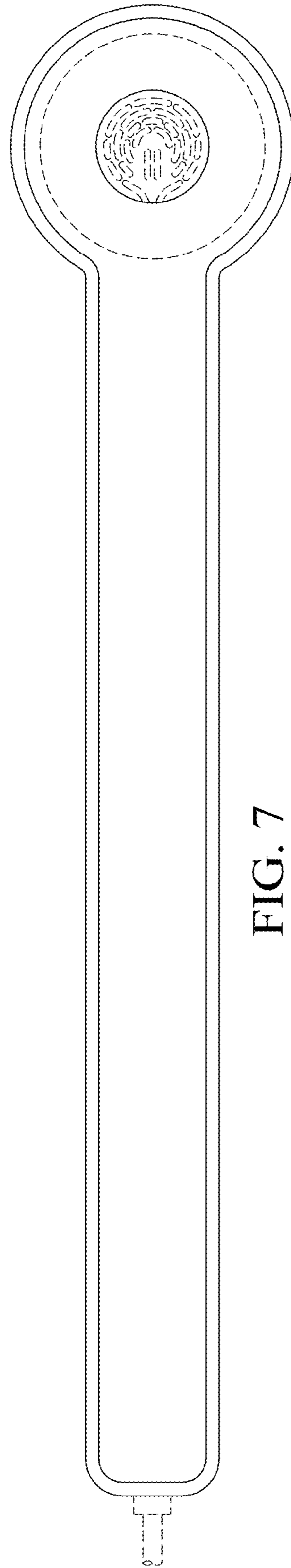

FIG. 7

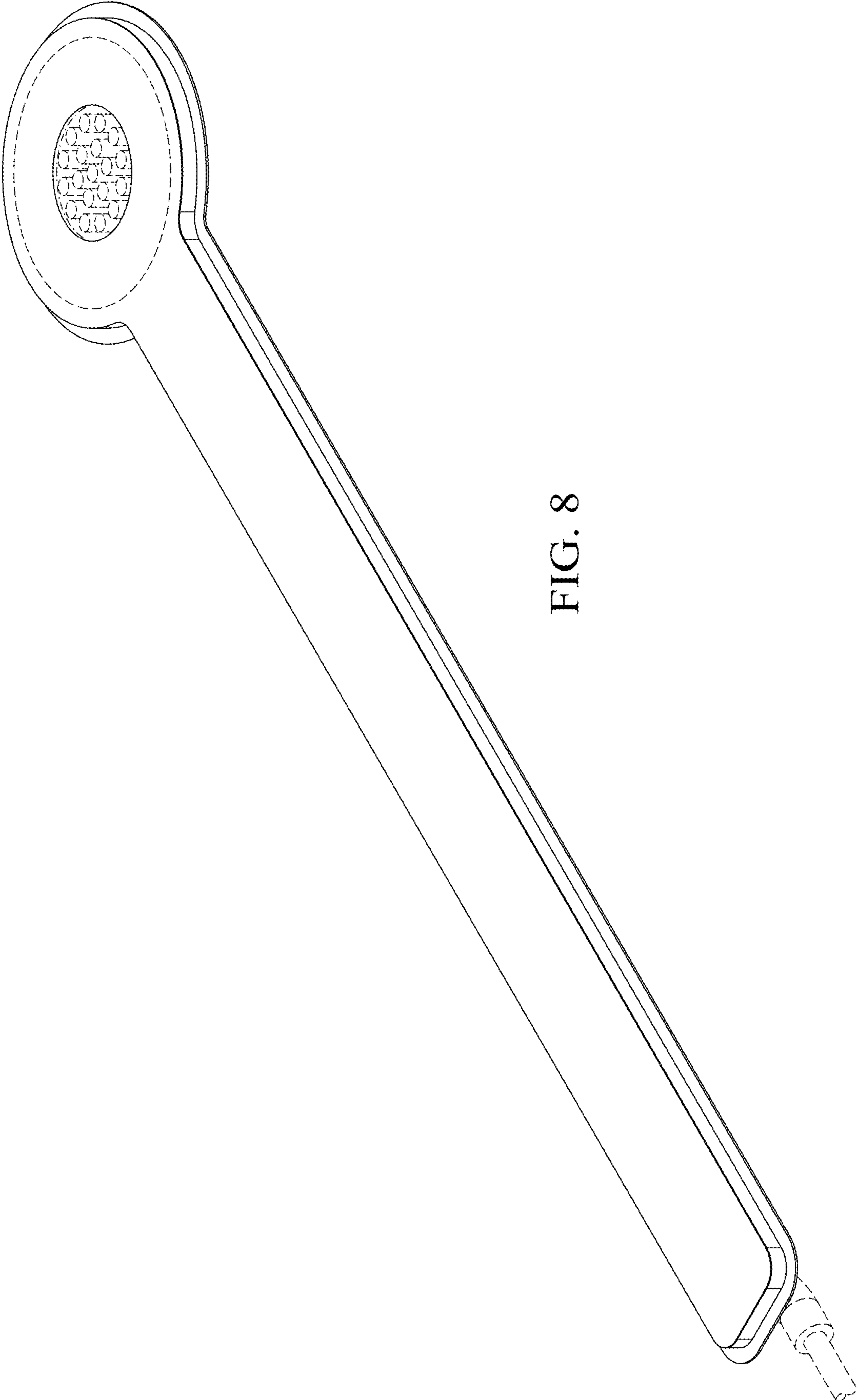

FIG. 8

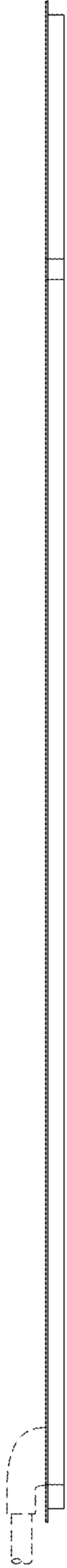

FIG. 9

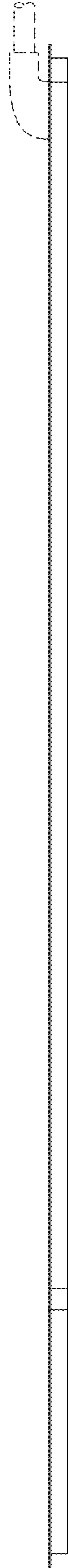

FIG. 10

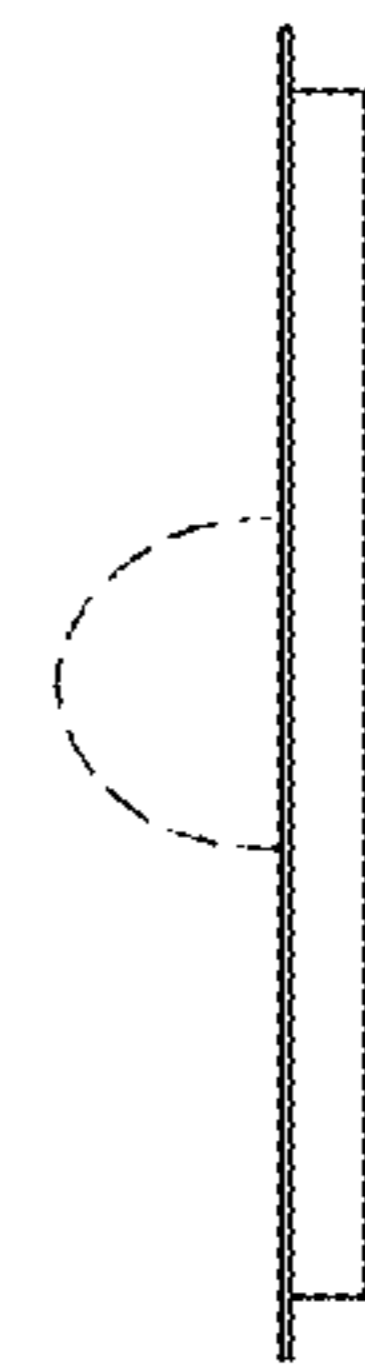

FIG. 11



FIG. 12

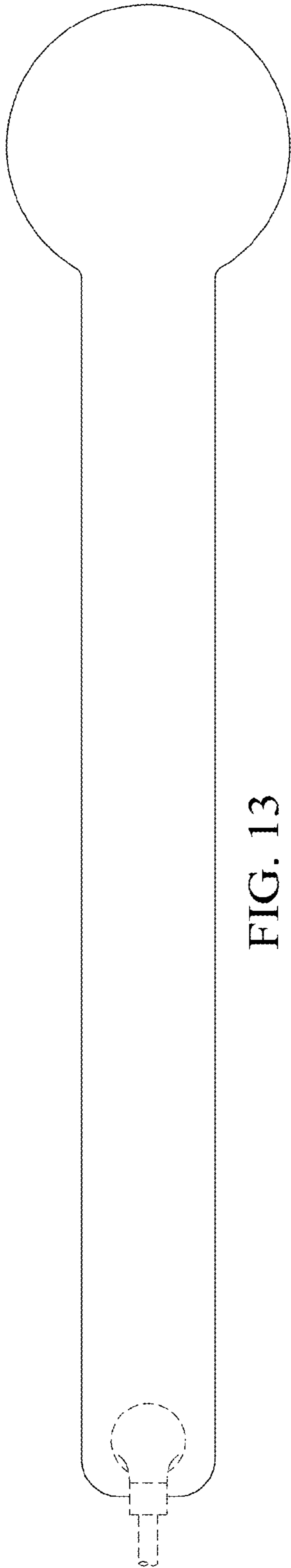

FIG. 13

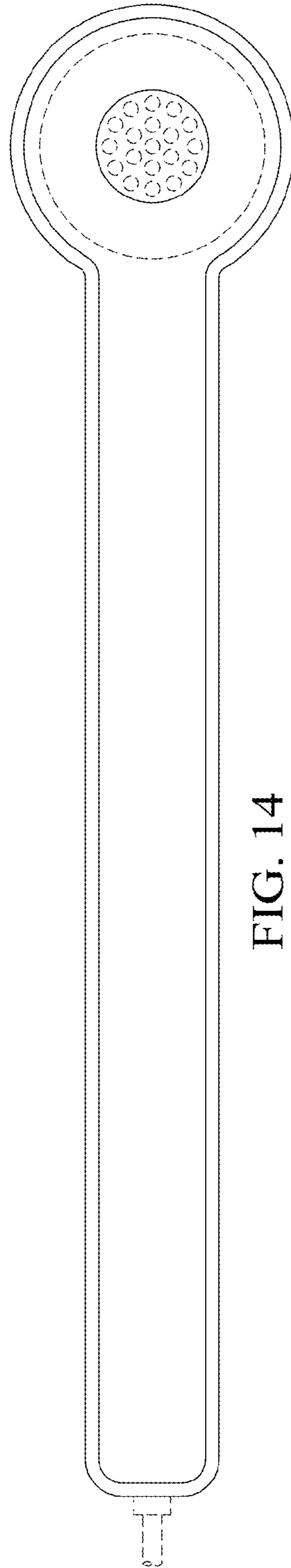

FIG. 14